

λ



RUS 2005/2006



Содержание

Информация о продукте

Кислородные датчики для оптимального понижения уровня отработавших газов (ОГ)	2
Принцип действия и техника	2
Испытание функционирования	3
Визуальный контроль	4
Кислородные датчики фирмы NTK	
Надежность благодаря качеству ...	4

Перечень производителей автомобилей, которые применяют кислородные датчики NTK

Alfa Romeo	5
Aston Martin	6
Audi	6
Autobianchi	10
Bertone	10
BMW	10
Chevrolet	15
Chrysler	16

Citroen	16	Skoda	54
Daewoo	19	SsangYong	55
Daimler	19	Steyr-Daimler-Puch	55
Ferrari	19	Subaru	55
Fiat	20	Suzuki	55
Ford	23	Toyota	55
Honda	27	Volvo	55
Hyundai	28	VW	58
Innocenti	28	Zastava	63
Jaguar	28		65
Lancia	29		
Land Rover	31		
Mazda	31	Техническая информация	
Mercedes Benz	32	Датчик - Производитель	66
MG	35	Рекомендационный перечень	70
Mitsubishi	36	NTK → NTK	86
Nissan	37	Информация о датчиках	87
Opel	38	Вид штекера	91
Peugeot	42	л.с. ↔ квт.	118
Renault	46	Принцип установки	118
Rover	50		
Saab	51		
Seat	52		

Примечания:

1. Данный перечень служит только для выбора типов.
2. После публикации этого издания все предыдущие перечни становятся недействительными.
3. Данное содержание не обуславливает правового притязания.



Кислотные датчики для оптимального понижения уровня отработавших газов.

Законные предписания в области отработавших газов обязывают автомобильную промышленность к понижению эмиссии отработавших газов. По этой причине сегодня все автомобили с двигателями внутреннего сгорания оснащаются трехкомпонентным каталитическим нейтрализатором. Нейтрализатор преобразует вредные отработавшие газы в газы с безвредным воздействием на экологию. Для эффективной работы нейтрализатора необходимо четко согласовать соотношение топлива и воздуха. Кислородный датчик постоянно проверяет состав отработавших газов. Кислородный датчик находится в передней части системы отработавших газов перед нейтрализатором. Датчик измеряет содержание остаточного количества кислорода в отработавших газах. С помощью выходного сигнала

он регулирует систему управления двигателем, которая в свою очередь с помощью карбюратора производит четкую настройку топливоздушную смеси (см. рис. I). Данный, так называемый замкнутый контур регулирования обеспечивает оптимальное соотношение составных компонентов смеси. Благодаря этому одновременно обеспечивается оптимальный уровень преобразующего

действия нейтрализатора, а также оптимальная мощность двигателя. С помощью второго кислородного датчика, находящегося за нейтрализатором, осуществляется постоянный контроль безупречного функционирования нейтрализатора и датчика, расположенного перед ним. В случае погрешности на панели приборов немедленно появляется оптический сигнал.

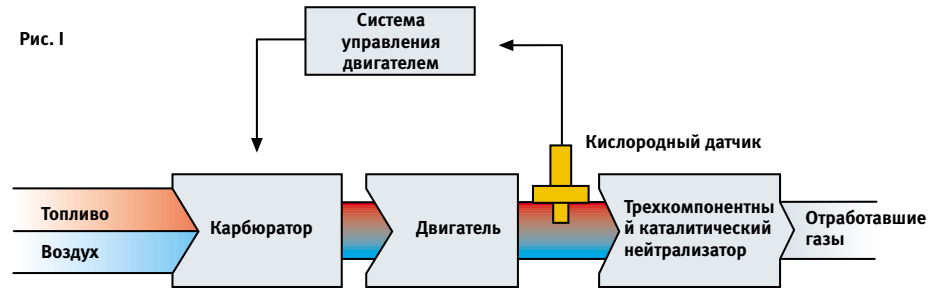

Функция и техника

Существуют различные типы кислородных датчиков. Их различие заключается в керамических элементах, с помощью которых производится измерение составных частей отработавших газов. Датчики окиси циркония: внешняя сторона элемента окиси циркония находится в непосредственном контакте с отработавшими газами. Внутренняя сторона имеет контакт с воздухом. На обеих сторонах элемента нанесено тонкое платиновое покрытие. Ионы кислорода проходят через элемент и оставляют на платиновом покрытии электрический заряд. При этом платиновое покрытие представляет собой электроды; сигнал датчика передается дальше от элемента к соединительному проводу датчика (см. рис. II). При температуре 300°C элемент окиси циркония

достигает проводящую способность для ионов кислорода. Если на обеих сторонах элемента окиси циркония концентрация кислорода различна, то по причине особых свойств элемента образуется напряжение. При обедненном соотношении топлива и воздуха возникает невысокое напряжение. Если же данное соотношение насыщено, то напряжение высокое. Типичный скачок

напряжения происходит при соотношении топлива и воздуха приблизительно на уровне 1:14,7 (см. рис. III). Данное соотношение можно также охарактеризовать коэффициентом избытка воздуха ($\lambda = 1$ соответствует соотношению топлива и воздуха в размере 1:14,7; т.е. при этом происходит полное сгорание).

Рис. II



Рис. III

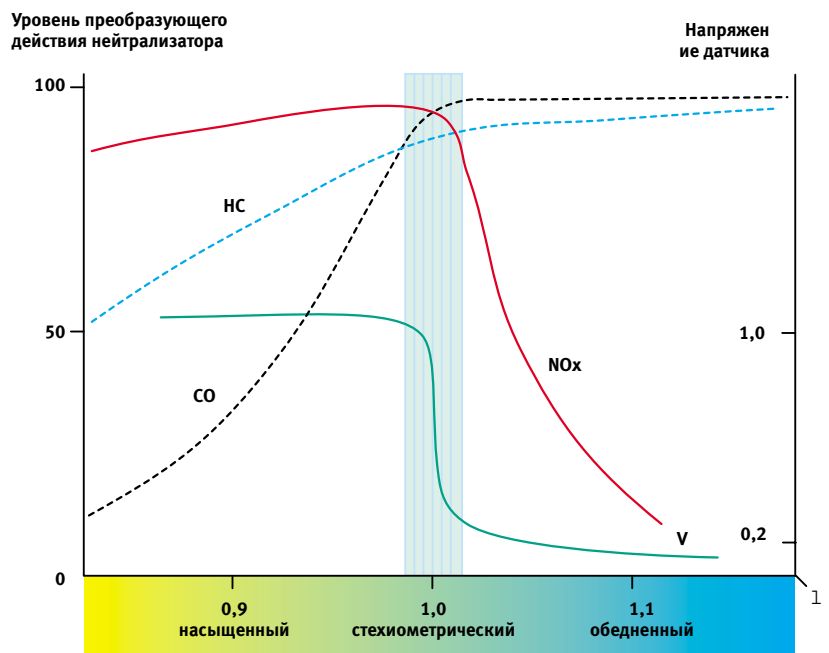

С помощью карбюратора либо электронного впрыскового механизма система управления двигателем регулирует соотношение топлива и воздуха. Необходимую для этого информацию система управления получает от кислородного датчика. Датчик создает напряжение только при достижении рабочей температуры свыше 300°C. По этой причине после старта двигателя элемент должен поработать определенное время для того, чтобы он нагрелся.

Сегодня почти все датчики оснащены внутренним керамическим нагревательным приспособлением, которое сокращает интервал времени до момента начала работы датчика. Датчики с нагревательными приспособлениями фирмы NTK являются примером многолетнего опыта в области толстопленочной и многослойной технологии. Благодаря им обеспечиваются высокое качество и надежность. Датчики окиси титана: элемент окиси титана не создает напряжение, как это происходит у элемента окиси циркония. Вместо этого производится изменение электрического сопротивления элемента окиси титана

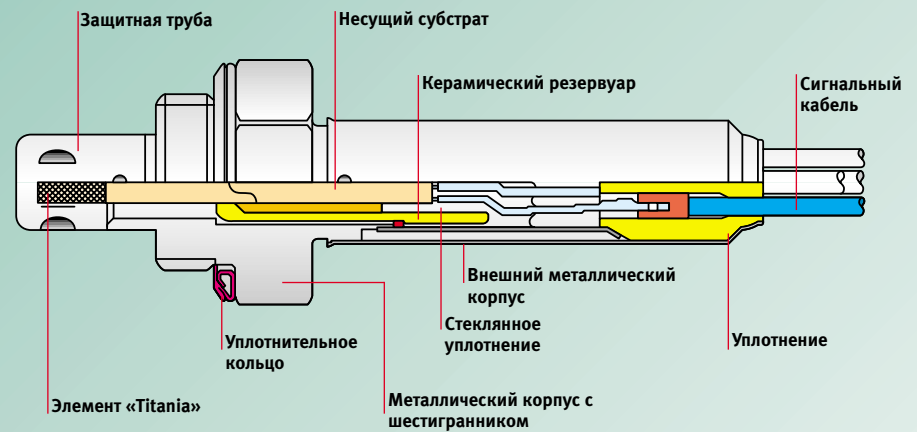

в зависимости от концентрации кислорода в отработавших газах. При величине Ламбда 1,0 сопротивление сильно изменяется. При подаче напряжения к элементу изменяется выходное напряжение в соответствии с концентрацией кислорода в отработавших газах. Датчик окиси титана в отличие от датчика окиси циркония не нуждается в исходном воздухе по причине другой конструкции его функционального механизма. В связи с этим датчик окиси титана имеет небольшие габариты. Элемент датчика, его платиновые электроды и нагревательный элемент устанавливаются на базе толстопленочной и многослойной технологии фирмы NTK на керамическом субстрате. Датчики на

основе окиси титана нельзя заменить датчиками на основе окиси циркония, и, наоборот, по причине их различных габаритов и стратегических видов управления, которые используются для анализа сигналов от датчиков.

Испытание функционирования

Кислородные датчики, вышедшие из строя или с дефектами, обуславливают проблемы, как, например, высокий расход топлива, выход из строя и повреждение каталитического нейтрализатора, плохие динамические свойства или отрицательная оценка при прохождении теста отработавших газов. Испытание кислородных датчиков производится с помощью осциллоскопа. Перед выполнением испытания необходимо обеспечить условие, при котором двигатель должен быть настроен согласно данным производителя. После этого двигатель должен поработать определенное время, и достигнуть рабочей температуры, так как кислородный датчик функционирует только при правильной температуре.

С помощью соответствующего соединительного устройства выход датчика подключается к осциллоскопу. Датчик нельзя отсоединять от системы управления двигателем. Число оборотов двигателя должно находиться приблизительно на уровне 2.000 об./мин. В случае правильного функционирования кислородного датчика величина скачка напряжения находится приблизительно в диапазоне от 0,2 до 0,8 Вольт. Время, необходимое для повышения от 0,1 Вольт до 0,9 Вольт (время реакции «обедненное состояние - насыщенное состояние»), должно составлять около 300 миллисекунд. Время реакции «обедненное состояние - насыщенное состояние» находится также в пределах этого диапазона. Если значение выхода датчика остается

постоянным или время реакции проходит медленно, то в данном случае кислородный датчик должен быть заменен.

Функционирование кислородного датчика необходимо проверять в рамках каждого технического осмотра и каждого контроля токсичности отработавших газов.

Медленно действующий датчик повышает расход топлива и в связи с этим такой датчик должен быть заменен.

Визуальный контроль

Для определения работоспособности кислородного датчика не достаточно выполнять визуальный контроль. Необходимо производить контроль соединительных линий и штекера, а также корпуса датчика, так как отклонения на этих участках обуславливают также искажение сигнала датчика. Повреждения на корпусе датчика говорят о механических ударах. Также состояние защитной трубы датчика может предоставить сведения о возможном неправильном функционировании.

Высокий уровень осаждения сажи приводит к закупорке датчика и отражается на времени реакции. Соотношение топлива и воздуха может быть чрезмерно насыщенным или же вышло из строя сенсорное нагревательное приспособление датчика. В любом случае такой датчик необходимо заменить.

Сажа



Высокий уровень осаждения белого или серого цвета указывает на использование присадок к топливу или на сгорание масла в двигателе. Определенные составные части в присадках к топливу и в масле загрязняют элемент датчика. Необходимо устранить причину загрязнения и заменить датчик.

Масло



Блестящие виды осаждения указывают на содержание свинца в топливе. Свинец производит разрушающее действие на платину, которая находится на элементе датчика и на каталитическом нейтрализаторе. При этом датчик должен быть заменен. После выполнения замены необходимо обратить внимание на то, чтобы использовалось исключительно только топливо без содержания свинца.

Свинец



Кислородные датчики фирмы NTK Надежность благодаря качеству

Результат многолетнего опыта: фирма NTK является ведущим производителем кислородных датчиков в мире. Благодаря многолетнему опыту в области разработок и изготовления кислородных датчиков фирма NTK в состоянии предложить соответствующий датчик почти для каждого автомобиля. Все составные

части, типы элементов, нагревательные сопротивления и соединительные штекера соответствуют оригинальным запчастям производителей, и предоставляют возможность для удобной установки без всяких проблем. Тщательные испытания, выполненные обществом технического

надзора (TÜV), а также «сертификат общего допуска к эксплуатации» (ABE) федерального автотранспортного учреждения гарантируют высокий уровень эксплуатационной надежности.

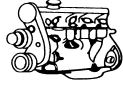

e kW



① ② ③

ORDER
STOCK
 No. No. L.No.
ALFA ROMEO

33 1.4i.e.	907 A	AR307.55	1.4	64	09.91-12.91		3	19	1665	OZA446-E49	0291	0412
33 1.4i.e. SW	907 B	AR307.55	1.4	64	09.91-12.91		3	19	1665	OZA446-E49	0291	0412
33 1.4i.e.	907 A	AR307.32	1.4	65	02.94-10.94		3	51	1700	OTA5F-3C1	1921	- - -
33 1.4i.e SW	907 B	AR307.32	1.4	65	02.94-10.94		3	51	1700	OTA5F-3C1	1921	- - -
33 1.5i.e.	907 A	AR307.51	1.5	70-72	06.90-03.92	(A) (NL)	3	19	1665	OZA446-E49	0291	0412
33 1.5i.e. SW	907 B	AR307.51	1.5	70-72	06.90-03.92	(A)	3	19	1665	OZA446-E49	0291	0412
33 1.5i.e. SW 4x4	907 B	AR307.51	1.5	70-72	06.90-03.92		3	19	1665	OZA446-E49	0291	0412
33 1.7i.e.	907 A	AR305.58	1.7	77	10.87-12.89		3	19	1665	OZA446-E49	0291	0412
33 1.7i.e. SW	905 A	AR305.58	1.7	77	09.88-12.89		3	19	1665	OZA446-E49	0291	0412
33 1.7i.e. SW 4x4	905 A	AR305.58	1.7	77	09.88-12.89		3	19	1665	OZA446-E49	0291	0412
33 1.7i.e. 4x4	907 A	AR307.37	1.7	79	07.90-03.92		3	19	1665	OZA446-E49	0291	0412
33 1.7i.e. SW	907 B	AR307.37	1.7	79	07.90-03.92		3	19	1665	OZA446-E49	0291	0412
33 1.7i.e. SW 4x4	907 B	AR307.37	1.7	79	07.90-03.92		3	19	1665	OZA446-E49	0291	0412
33 1.7i.e.	907 A	AR307.37	1.7	79	01.90-03.92		3	19	1665	OZA446-E49	0291	0412
33 1.7i.e. 16V	907 A	AR307.47	1.7	95	01.90-10.94		3	19	1665	OZA446-E49	0291	0412
33 1.7i.e. 16V 4x4	907 A	AR307.47	1.7	95	01.90-10.94		3	19	1665	OZA446-E49	0291	0412
33 1.7i.e. 16V SW 4x4	907 B	AR307.47	1.7	95	06.90-10.94		3	19	1665	OZA446-E49	0291	0412
33 1.7i.e. 16V 4x4	907 A	AR307.47	1.7	97	06.90-09.94		3	19	1665	OZA446-E49	0291	0412
75 1.6i.e.	162 B	611.01	1.6	77-79	08.89-02.92		3	19	895	OZA446-E4	1877	0412
75 1.8i.e.	162 B	612.01	1.8	88	08.89-02.92		3	19	895	OZA446-E4	1877	0412
75 2.0 T.S.	162 B	061.66	2.0	106	09.87-05.90		3	19	1100	OZA446-E5	1838	0412
75 3.0 V6	162 B	061.24	3.0	133	02.87-01.90		3	19	895	OZA446-E4	1877	0412
75 3.0 V6	162 B	061.503	3.0	139-141	02.90-02.92		3	19	895	OZA446-E4	1877	0412
75 3.0 ES Coupe Zagato	162 B	615.01	3.0	152	03.89-02.92		3	19	895	OZA446-E4	1877	0412
145 1.4i.e.	930	AR33.501	1.4	66	08.94-02.97		3	51	1000	OTA6F-3A1	1928	- - -
145 1.4 i.e. 16V T.S. [G97]	930	AR33.503	1.4	76	11.96-02.99	Fg.Nr. 0165088 ->	4	40	1175	OZA527-E24	0287	1919
145 1.4 i.e. 16V T.S. [G97]	930	AR33.503	1.4	76	11.96-02.99	->Fg.Nr. 0129332	4	40	972	OZA527-E7	0213	1919
145 1.4 i.e. 16V T.S. [G99]	930	AR33.503	1.4	76	02.99-12.01		4	40	1175	OZA527-E24	0287	1919
145 1.6i.e	930	AR33.201	1.6	78	04.94-12.94		4	40	972	OZA527-E7	0213	1919
145 1.6i.e. 16V T.S. [G99]	930	AR32.101	1.6	88	02.99-12.01		4	40	1175	OZA527-E24	0287	1919
145 1.6i.e. 16V T.S. [G99]	930	AR67.601	1.6	88	02.99-10.99		4	40	1175	OZA527-E24	0287	1919
145 1.6i.e. 16V T.S.	930	AR67.601	1.6	88	11.96-02.99		4	40	972	OZA527-E7	0213	1919
145 1.7i.e 16V	930	AR33.401	1.7	96	04.94-11.96		4	40	972	OZA527-E7	0213	1919
145 1.8i.e. 16V T.S. [G99]	930	AR32.201	1.8	103	02.99-12.01		4	40	1175	OZA527-E24	0287	1919
145 1.8i.e. 16V T.S.	930	AR32.201	1.8	103	05.98-01.99		4	40	972	OZA527-E7	0213	1919
145 1.8i.e. 16V T.S.	930	AR67.106	1.8	103	11.96-04.98		4	40	972	OZA527-E7	0213	1919
145 1.8i.e. 16V T.S. [G97]	930	AR67.106	1.8	103	11.96-05.98		4	40	972	OZA527-E7	0213	1919
145 1.8i.e. 16V T.S. [G97]	930	AR32.201	1.8	103	11.96-05.98		4	40	972	OZA527-E7	0213	1919
145 2.0ti 16V T.S. [G99]	930	AR32.301	2.0	110	02.99-10.99		4	40	1175	OZA527-E24	0287	1919
145 2.0i.e. 16V T.S.	930	AR67.204	2.0	110	10.95-04.98		4	40	972	OZA527-E7	0213	1919
146 1.4i.e.	930	AR33.501	1.4	66	08.94-02.97		3	51	1000	OTA6F-3A1	1928	- - -
146 1.4i.e. 16V T.S. [G99]	930	AR33.503	1.4	76	02.99-10.99		4	40	1175	OZA527-E24	0287	1919
146 1.4i.e. 16V T.S. [G97]	930	AR33.503	1.4	76	11.96-02.99	Fg.Nr. VET 0165088 ->	4	40	1175	OZA527-E24	0287	1919
146 1.4i.e. 16V T.S. [G97]	930	AR33.503	1.4	76	11.96-05.98	-> Fg.Nr. VET 0129332	4	40	972	OZA527-E7	0213	1919
146 1.6i.e.	930	AR33.201	1.6	78	04.94-12.94		4	40	972	OZA527-E7	0213	1919
146 1.6i.e. 16V T.S. [G99]	930	AR67.601	1.6	88	02.99-10.99		4	40	1175	OZA527-E24	0287	1919
146 1.6i.e. 16V T.S. [G99]	930	AR32.101	1.6	88	02.99-12.01		4	40	1175	OZA527-E24	0287	1919
146 1.6i.e. 16V T.S. [G97]	930	AR67.601	1.6	88	11.96-02.99		4	40	972	OZA527-E7	0213	1919
146 1.7i.e. 16V	930	AR33.401	1.7	96	12.94-11.96		4	40	972	OZA527-E7	0213	1919
146 1.8i.e. 16V T.S. [G99]	930	AR32.201	1.8	103	02.99-12.01		4	40	1175	OZA527-E24	0287	1919
146 1.8i.e. 16V T.S.	930	AR67.106	1.8	103	11.96-04.98		4	40	972	OZA527-E7	0213	1919

Fg = Chassis No.

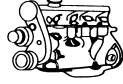

ℓ kW



① ② ③

ORDER
STOCK
REVISION
No. No. L No.**ALFA ROMEO**

146 1.8i.e. 16V T.S. [G97] 930	AR32.201 / AR67.106	1.8	103	11.96-02.99		4	40	972	OZA527-E7	0213	1919
146 2.0ti 16V T.S. [G99] 930	AR32.301	2.0	110	02.99-12.01		4	40	1175	OZA527-E24	0287	1919
146 2.0ti 16V T.S. 930	AR67.204	2.0	110	10.95-04.98		4	40	972	OZA527-E7	0213	1919
155 1.6i 16V T.S. 167	AR67.601	1.6	85	05.96-10.97		4	40	972	OZA527-E7	0213	1919
155 1.7i T.S. 167	AR67.105	1.7	85	04.93-04.96		4	38	1130	OZA527-E5	0253	1919
155 1.7i T.S. 167	AR67.103	1.7	95	02.92-04.93		4	38	1130	OZA527-E5	0253	1919
155 1.8i T.S. 167	AR67.101 / 102	1.8	93	02.92-04.96		4	38	1130	OZA527-E5	0253	1919
155 1.8i 16V T.S. 167	AR67.106	1.8	100	05.96-10.97		4	40	972	OZA527-E7	0213	1919
155 2.0i T.S. 167	AR67.202	2.0	104	04.93-02.95		4	38	1130	OZA527-E5	0253	1919
155 2.0i 16V T.S. 167	AR67.204	2.0	110	03.95-10.97		4	40	972	OZA527-E7	0213	1919
155 2.5i V6 167	AR67.301	2.5	120	02.92-04.96		4	38	1130	OZA527-E5	0253	1919
155 2.5i V6 167	AR67.303	2.5	121	05.96-10.97		4	38	880	OZA527-E4	0218	1919
156 1.6i 16V T.S. 932	AR67.601	1.6	88	10.99-09.00	->Fg.Nr. VET 0012328	3	22	890	OZA446-E18	1887	0412
156 1.6i 16V T.S. 932	AR32.102	1.6	88	10.99-09.00	Fg.Nr. VET 0023373 ->	4	40	1175	OZA527-E24	0287	1919
156 1.6i 16V T.S. 932	AR67.601	1.6	88	10.99-09.00	Fg.Nr. VET 0023373 ->	4	40	1175	OZA527-E24	0287	1919
156 1.8i 16V T.S. 932	AR32.201	1.8	106	12.97-09.00		4	40	1175	OZA527-E24	0287	1919
156 2.0i 16V T.S. 932	AR32.301	2.0	114	12.97-09.00		4	40	1175	OZA527-E24	0287	1919
164 2.0 T.S. 164	AR064.16	2.0	102	01.88-09.92		3	19	895	OZA446-E4	1877	0412
164 2.0 T.S. 164	AR64.103	2.0	106	12.93-10.98		4	38	880	OZA527-E4	0218	1919
164 2.0i.e V6 Turbo 164	AR64.102	2.0	148	03.91-09.92		3	19	1100	OZA446-E5	1838	0412
164 2.0i.e V6 Turbo 164	AR64.102	2.0	148	09.92-10.98		3	19	1100	OZA446-E5	1838	0412
164 3.0i.e. 164	064.12	3.0	132	04.88-05.91		3	19	895	OZA446-E4	1877	0412
164 3.0i.e. 164	064.12	3.0	132	06.91-09.92		3	19	1100	OZA446-E5	1838	0412
164 3.0i.e. QV 164	064.30	3.0	147	09.90-05.91		3	19	895	OZA446-E4	1877	0412
164 3.0i.e. QV 164	064.30	3.0	147	06.91-09.92		3	19	1100	OZA446-E5	1838	0412
164 3.0i.e. Q4 4x4 164	64.307 / 66.304	3.0	171	12.93-10.98		4	38	880	OZA527-E4	0218	1919
166 2.0 T.S. 936	AR34.103	2.0	114	10.98-		4	40	1175	OZA527-E24	0287	1919
166 2.0 Turbo V6 936	AR34.102	2.0	151	10.98-	①	4	40	1175	OZA527-E24	0287	1919
166 2.5 V6 24V 936	AR34.201	2.5	140	10.98-		4	40	1175	OZA527-E24	0287	1919
166 3.0 V6 24V 936	AR34.301	3.0	166	10.98-		4	40	1175	OZA527-E24	0287	1919
GTV 1.8 16V T.S. (95) 916 C	AR32.201	1.8	106	03.98-		4	40	1175	OZA527-E24	0287	1919
GTV 2.0 16V T.S. (95) 916 C	AR16.201	2.0	110	04.95-03.98		3	22	890	OZA446-E18	1887	0412
GTV 2.0 16V T.S. (95) 916 C	AR16.201	2.0	114	04.98-11.99		4	40	1175	OZA527-E24	0287	1919
GTV 3.0 24V V6 (95) 916 C	AR16.102	3.0	162	11.96-03.98		3	22	890	OZA446-E18	1887	0412
Spider 1.8 16V T.S. (95) 916 S	AR32.201	1.8	106	03.98-		4	40	1175	OZA527-E24	0287	1919
Spider 2.0i.e. 916 S	AR015.88	2.0	88	01.90-12.94		3	19	895	OZA446-E4	1877	0412
Spider 2.0 16V T.S. (95) 916 S	AR16.201 / 32.301	2.0	110-114	04.98-11.99		4	40	1175	OZA527-E24	0287	1919
Spider 2.0 16V T.S. (95) 916 S	AR16.201	2.0	110-114	04.95-03.98		3	22	890	OZA446-E18	1887	0412
Spider 3.0 V6 12V (95) 916 S	AR16.101	3.0	141	04.95-11.99		3	22	890	OZA446-E18	1887	0412
Sprint 1.7i.e. 902 A	305.58	1.7	77	10.87-12.89		3	19	1665	OZA446-E49	0291	0412

ASTON MARTIN

DB7 5.9		5.9	309	03.99-		4	32	393	OZA381-D3	0462	1952
DB7 Vantage 3.2		3.2	250	01.94-		4	32	393	OZA201-AM1	0168	1952
DB7 Vantage 3.2		3.2	250	01.94-		4	32	393	OZA201-AM2	0179	1952
DB7 Volante 3.2		3.2	250	01.96-		4	32	393	OZA201-AM1	0168	1952
DB7 Volante 3.2		3.2	250	01.96-		4	32	393	OZA201-AM2	0179	1952

AUDI

80	ABM	1.6	51	01.92-01.96		3	19	710	OZA446-E50	0204	0412
----	-----	-----	----	-------------	--	---	----	-----	------------	------	------

Fg = Chassis No.

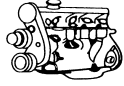

e kW



① ② ③

ORDER
STOCK
 No. No. L.No.
AUDI

80	ADA	1.6	75	06.93-01.96		3	19	975	OZA446-E2	1855	0412
80	PM	1.8	66	03.88-08.91		1	3	472	OZA401-E2	1802	1951
80	JN	1.8	68	08.83-08.86		1	3	472	OZA401-E2	1802	1951
80 Quattro	JN	1.8	68	08.85-08.86		3	19	975	OZA446-E2	1855	0412
80	PV	1.8	81	08.85-08.86		3	19	975	OZA446-E2	1855	0412
80	SD	1.9	83	09.87-07.88		3	19	975	OZA446-E2	1855	0412
80	ABT	2.0	66	09.91-01.96		3	19	365	OZA446-E12	1805	0412
80	ABT	2.0	66	09.91-01.96		3	19	710	OZA446-E50	0204	0412
80	3A	2.0	83-85	08.88-10.90		3	19	975	OZA446-E2	1855	0412
80	AAD	2.0	83-85	10.90-08.91		3	19	975	OZA446-E2	1855	0412
80	ABK	2.0	85	09.91-01.96		3	19	975	OZA445-E7	0269	0412
80	ABK	2.0	85	09.91-01.96		3	19	1215	OZA446-E16	1859	0412
80 Quattro	ABK	2.0	85	09.91-01.96		3	19	975	OZA445-E7	0269	0412
80	6A	2.0	101-103	03.90-07.92		3	19	975	OZA446-E2	1855	0412
80	ACE	2.0	103	08.92-01.96		3	19	975	OZA446-E2	1855	0412
80	WE	2.1	85	10.80-08.83	①	1	3	472	OZA401-E2	1802	1951
80 S2 Quattro	ABY	2.2	169	02.93-01.96		3	19	975	OZA446-E2	1855	0412
80 RS2 Quattro Avant	ADU	2.2	232	03.94-05.95		3	19	975	OZA446-E2	1855	0412
80	NG	2.3	98	09.91-01.96		3	19	1215	OZA446-E16	1859	0412
80	ABC	2.6	110	07.92-01.96		3	19	490	OZA446-E11	1898	0412
80	ABC	2.6	110	07.92-01.96		3	19	710	OZA446-E50	0204	0412
80 Quattro	AAH	2.8	128	08.92-01.96		3	19	710	OZA446-E50	0204	0412
80	AAH	2.8	128	08.92-01.96		3	19	710	OZA446-E50	0204	0412
90	SK	2.0	83	02.86-03.87		1	3	472	OZA401-E2	1802	1951
90	PS	2.0	85	04.87-07.91		3	19	975	OZA445-E7	0269	0412
90	KX	2.2	85	01.85-03.87		1	3	472	OZA401-E2	1802	1951
90 Quattro	JT	2.2	88	10.84-03.87		3	19	975	OZA446-E2	1855	0412
90	NG	2.3	100	04.87-09.91		3	19	1215	OZA446-E16	1859	0412
90 20V	7A	2.3	125	08.88-09.91		3	19	975	OZA446-E2	1855	0412
100	4B	1.8	66	01.88-10.89		1	3	472	OZA401-E2	1802	1951
100	PH	1.8	66	04.85-07.88		1	3	472	OZA401-E2	1802	1951
100	AAE	2.0	74	12.90-07.94		3	19	975	OZA445-E7	0269	0412
100	AAE	2.0	74	12.90-09.92	->4A-P-022 306	3	19	490	OZA446-E11	1898	0412
100	RT	2.0	83	01.88-11.90		3	19	975	OZA446-E2	1855	0412
100 Quattro	AAD	2.0	85	12.90-07.92		3	19	975	OZA445-E7	0269	0412
100	AAD	2.0	85	01.91-12.92		3	19	975	OZA445-E7	0269	0412
100	AAD	2.0	85	01.91-12.92		3	19	975	OZA446-E2	1855	0412
100	ABK	2.0	85	01.93-07.94		3	19	975	OZA446-E2	1855	0412
100 16V	ACE	2.0	101-103	01.92-07.94		3	19	975	OZA446-E2	1855	0412
100	KZ	2.2	85-88	10.84-09.86		1	3	472	OZA401-E2	1802	1951
100 Quattro	PX	2.2	88	08.85-07.86		3	19	975	OZA446-E2	1855	0412
100 Quattro Turbo	MC	2.2	121	11.88-11.90	K-038 262->	3	19	1215	OZA446-E16	1859	0412
100 Quattro Turbo	MC	2.2	121	03.86-11.88	->K-038 261	3	19	975	OZA446-E2	1855	0412
100 S4	AAN	2.2	169	08.91-07.94		3	19	975	OZA445-E7	0269	0412
100 S4	AAN	2.2	169	08.91-07.94		3	19	975	OZA446-E2	1855	0412
100	AAR	2.3	98	12.90-07.94		3	19	1215	OZA446-E16	1859	0412
100	NF	2.3	100	07.89-11.90	44-L-000-001->	3	19	1215	OZA446-E16	1859	0412
100	ABC	2.6	110	04.92-07.94		3	19	490	OZA446-E11	1898	0412
100	ABC	2.6	110	03.92-07.94		3	19	710	OZA446-E50	0204	0412
100	AAH	2.8	128	12.90-09.92	->4A-P-022 306	3	19	490	OZA446-E11	1898	0412
100	AAH	2.8	128	09.92-07.94	4A-P-022 307->	3	19	710	OZA446-E50	0204	0412
100	AAH	2.8	128	12.90-07.94		3	19	710	OZA446-E50	0204	0412

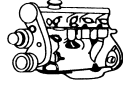

ℓ kW



① ② ③

ORDER
No. No. STOCK
REVISION
L.No.**AUDI**

100 S4 Quattro	ABH	4.2	206	10.92-07.94		3	19	975	OZA445-E7	0269	0412	
200 Turbo	MC	2.2	118-121	08.85-12.91		3	19	975	OZA446-E2	1855	0412	
200 Turbo Quattro	MC	2.2	118-121	01.85-11.88	->44-K-038 261	3	19	975	OZA446-E2	1855	0412	
200 Turbo Quattro	MC	2.2	118-121	11.88-12.90	44-K-038 262->	3	19	1215	OZA446-E16	1859	0412	
200 Turbo Quattro	3B	2.2	162	03.89-12.90		3	19	975	OZA446-E2	1855	0412	
200	NF	2.3	100	11.86-07.89		3	19	1665	OZA446-E49	0291	0412	
A2	AUA	1.4	55	02.00-		5	92	250	LZA11-V1	1825	- - -	
A2	AUA	1.4	55	02.00-		4	65	620	OZA510-AU1	1782	1952	
A2	BBY	1.4	55	02.00-		5	92	250	LZA11-V1	1825	- - -	
A2	BBY	1.4	55	02.00-		4	65	620	OZA510-AU1	1782	1952	
A3	AKL	1.6	74	08.97-07.98	Fg.Nr. 8L-V-095 001->	4	64	470	OZA447-E17	0270	1952	
					8L-W-150 000							
A3	AEH	1.6	74	04.97-07.98	Fg.Nr. 8L-V-095 001->	4	64	470	OZA447-E17	0270	1952	
					8L-W-150 000							
A3	8PI	BGU	1.6	75	05.03-	5	92	750	LZA07-V1	1851	- - -	
A3	8PI	BGU	1.6	75	05.03-		4	85	471	OZA510-V11	1884	1952
A3	AGN	1.8	92	09.96-07.97		4	64	700	OZA447-E32	0471	1952	
A3	AGN	1.8	92	07.99-11.00		4	64	620	OZA447-E18	0281	1952	
A3	AGU	1.8	110	12.96-07.97	Fg.Nr. 8L-V-050 001->	4	66	1140	OZA447-E25	0494	1952	
					8L-V-150 000							
A3	AGU	1.8	110	12.96-11.00	-> Fg.Nr. 8L-V-050 000	4	48	985	OZA447-E30	0449	1952	
A3 Quattro	AGU	1.8	110	08.97-11.00		4	64	700	OZA447-E32	0471	1952	
A3	AGU	1.8	110	12.96-11.00	Fg.Nr. 8L-W-000 001->	4	64	700	OZA447-E32	0471	1952	
A4	ANA	1.6	74	06.99-07.00		4	65	700	OZA334-AU1	0474	1952	
A4	ANA	1.6	74	07.99-07.00		4	64	1055	OZA516-AU1	0452	1952	
A4	ANA	1.6	74	07.99-11.00		4	65	780	OZA334-AU2	1789	1952	
A4	ADP	1.6	74	11.94-10.96		4	48	967	OZA447-E14	0129	1952	
A4	ALZ	1.6	75	07.99-11.00		4	64	1055	OZA516-AU1	0452	1952	
A4	ALZ	1.6	75	06.99-11.00		4	65	700	OZA334-AU1	0474	1952	
A4 Quattro	AFY	1.8	85	07.95-11.00		4	48	985	OZA447-E30	0449	1952	
A4	ADR	1.8	92	11.94-11.00		4	48	967	OZA447-E14	0129	1952	
A4 Quattro	ADR	1.8	92	11.94-11.00		4	48	985	OZA447-E30	0449	1952	
A4 Avant Quattro	ADR	1.8	92	11.94-11.00		4	48	985	OZA447-E30	0449	1952	
A4 Avant Quattro	AEB	1.8	110	07.96-07.97		4	66	1140	OZA447-E25	0494	1952	
A4	AEB	1.8	110	07.96-07.97		4	66	1140	OZA447-E25	0494	1952	
A4 Quattro	AEB	1.8	110	07.96-07.97		4	66	1140	OZA447-E25	0494	1952	
A4 Avant	AEB	1.8	110	07.96-07.97		4	66	1140	OZA447-E25	0494	1952	
A4	AEB	1.8	110	08.97-07.98		4	66	1350	OZA447-E35	0493	1952	
A4	APU	1.8	110	08.98-11.00		4	66	1350	OZA447-E35	0493	1952	
A4 Avant Quattro	APU	1.8	110	08.98-11.00		4	66	1350	OZA447-E35	0493	1952	
A4 Avant	AEB	1.8	110	08.97-07.98		4	66	1350	OZA447-E35	0493	1952	
A4 Avant	APU	1.8	110	08.98-11.00		4	66	1350	OZA447-E35	0493	1952	
A4 Avant Quattro	AEB	1.8	110	08.97-07.98		4	66	1350	OZA447-E35	0493	1952	
A4 Avant Quattro	AJL	1.8	132	08.97-11.00		4	66	1350	OZA447-E35	0493	1952	
A4 Avant	AJL	1.8	132	08.97-11.00		4	66	1350	OZA447-E35	0493	1952	
A4	AJL	1.8	132	08.97-11.00		4	66	1350	OZA447-E35	0493	1952	
A4	ABC	2.6	110	11.94-11.00		3	26	410	OZA446-E43	0194	0412	
A4	AAH	2.8	128	11.94-11.00		3	26	410	OZA446-E43	0194	0412	
A6 Quattro	ADR	1.8	92	10.95-10.97		4	48	550	OZA447-E16	0259	1952	
A6	ADR	1.8	92	06.94-10.97		4	48	550	OZA447-E16	0259	1952	
A6 Quattro	AEB	1.8	110	04.97-06.98		4	66	1140	OZA447-E25	0494	1952	
A6 Avant Quattro	AEB	1.8	110	02.98-06.98		4	66	1140	OZA447-E25	0494	1952	

Fg = Chassis No.

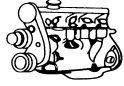

ℓ kW



① ② ③

ORDER
STOCK
 No. No. L.No.
AUDI

A6 Avant Quattro	AEB	1.8	110	07.98-01.99		4	66	1350	OZA447-E35	0493	1952
A6 Avant	AEB	1.8	110	07.98-01.99		4	66	1350	OZA447-E35	0493	1952
A6	AEB	1.8	110	04.97-		4	66	1350	OZA447-E35	0493	1952
A6 Quattro	AEB	1.8	110	07.98-01.99		4	66	1350	OZA447-E35	0493	1952
A6 Avant	AJL	1.8	132	07.98-		4	66	1350	OZA447-E35	0493	1952
A6 Quattro	AJL	1.8	132	07.98-		4	66	1350	OZA447-E35	0493	1952
A6	AJL	1.8	132	08.98-		4	66	1350	OZA447-E35	0493	1952
A6 Avant Quattro	AJL	1.8	132	07.98-		4	66	1350	OZA447-E35	0493	1952
A6 Avant Quattro	AJL	1.8	132	02.98-06.98		4	66	1140	OZA447-E25	0494	1952
A6 Quattro	AJL	1.8	132	06.97-06.98		4	66	1140	OZA447-E25	0494	1952
A6	AAE	2.0	74	06.94-08.96		3	19	975	OZA445-E7	0269	0412
A6	ACE	2.0	103	06.94-		3	19	975	OZA446-E2	1855	0412
A6	AAR	2.3	98	06.94-		3	19	1215	OZA446-E16	1859	0412
A6	ALF	2.4	120	06.97-		4	48	520	OZA448-E31	0151	1952
A6	AJG	2.4	120	04.97-		4	48	520	OZA448-E31	0151	1952
A6	AGA	2.4	121	04.97-		4	48	520	OZA448-E31	0151	1952
A6	BDW	2.4	130	05.04-		5	91	600	LZA07-AU1	1772	- - -
A6	BDW	2.4	130	05.04-		4	84	971	OZA510-AU2	1783	1952
A6	BDW	2.4	130	05.04-		4	85	971	OZA510-AU3	1784	1952
A6	ABC	2.6	110	06.94-		3	19	490	OZA446-E11	1898	0412
A6	ABC	2.6	110	06.94-07.95		3	19	710	OZA446-E50	0204	0412
A6 Quattro	ABC	2.6	110	09.94-10.97	4A-S-026 715->	3	19	710	OZA446-E50	0204	0412
A6 Quattro	AEJ	2.8	120	06.94-10.97		3	19	710	OZA446-E50	0204	0412
A6	AAH	2.8	128	06.94-10.97		3	19	710	OZA446-E50	0204	0412
A6	AAH	2.8	128	06.94-07.95		3	19	710	OZA446-E50	0204	0412
A6 Quattro	AAH	2.8	128	06.94-10.97		3	19	710	OZA446-E50	0204	0412
A6	ACK	2.8	142	04.97-		4	48	520	OZA448-E31	0151	1952
A6	ALG	2.8	142	06.97-		4	48	520	OZA448-E31	0151	1952
A6 FSI	AUK	3.2	188	05.04-		5	91	600	LZA07-AU1	1772	- - -
A6 FSI Quattro	AUK	3.2	188	05.04-		5	91	600	LZA07-AU1	1772	- - -
A6 FSI	AUK	3.2	188	05.04-		4	84	971	OZA510-AU2	1783	1952
A6 FSI Quattro	AUK	3.2	188	05.04-		4	84	971	OZA510-AU2	1783	1952
A6 FSI	AUK	3.2	188	05.04-		4	85	971	OZA510-AU3	1784	1952
A6 FSI Quattro	AUK	3.2	188	05.04-		4	85	971	OZA510-AU3	1784	1952
A8	AAH	2.8	128	06.94-03.96		3	19	710	OZA446-E50	0204	0412
A8	AGW	3.7	169	07.95-		4	48	720	OZA447-E31	0460	1952
A8 Quattro	AGW	3.7	169	07.95-11.98		4	48	720	OZA447-E31	0460	1952
A8 Quattro	AEM	4.2	180	03.94-07.96		4	48	720	OZA447-E31	0460	1952
A8 Quattro	ABZ	4.2	220	03.94-11.98		4	48	720	OZA447-E31	0460	1952
A8 S 8 Quattro	AHC	4.2	250	07.96-06.99		4	48	720	OZA447-E31	0460	1952
Cabrio	ABK	2.0	85	01.93-		3	19	975	OZA445-E7	0269	0412
Cabrio	ABK	2.0	85	01.93-		3	19	975	OZA446-E2	1855	0412
Cabrio	ACE	2.0	103	05.95-	①	3	19	975	OZA446-E2	1855	0412
Cabrio	NG	2.3	98-100	05.91-07.94		3	19	1215	OZA446-E16	1859	0412
Cabrio	ABC	2.6	110	01.94-		3	19	490	OZA446-E11	1898	0412
Cabrio	AAH	2.8	128	11.92-		3	19	710	OZA446-E50	0204	0412
Coupe	JN	1.8	66-68	01.85-10.88		1	3	472	OZA401-E2	1802	1951
Coupe	PV	1.8	79	08.86-10.88		3	19	975	OZA446-E2	1855	0412
Coupe	3A	2.0	83-85	05.89-07.90		3	19	975	OZA445-E7	0269	0412
Coupe	3A	2.0	83-85	05.89-07.90		3	19	975	OZA446-E2	1855	0412
Coupe	AAD	2.0	83-85	08.90-07.91		3	19	975	OZA446-E2	1855	0412
Coupe	ABK	2.0	85	09.91-		3	19	975	OZA446-E2	1855	0412

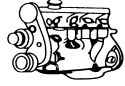

ℓ kW



① ② ③

ORDER
No. No. STOCK
REVISIONS
L. No.**AUDI**

Coupe	ABK	2.0	85	09.91-		3	19	975	OZA445-E7	0269	0412
Coupe	ACE	2.0	103	08.92-		3	19	975	OZA446-E2	1855	0412
Coupe	KX	2.2	85	01.84-10.88		1	3	472	OZA401-E2	1802	1951
Coupe	JT	2.2	89	12.84-10.88		3	19	975	OZA446-E2	1855	0412
Coupe S2	ABY	2.2	169	10.92-		3	19	975	OZA445-E7	0269	0412
Coupe Quattro	NG	2.3	98-100	08.89-07.94		3	19	1215	OZA446-E16	1859	0412
Coupe	7A	2.3	125	08.89-07.91	8B-L-000 001->	3	19	1215	OZA446-E16	1859	0412
Coupe 20V Quattro	7A	2.3	125	11.88-07.89	->8B-K-020 000	3	19	975	OZA446-E2	1855	0412
Coupe	ABC	2.6	110	08.92-08.94	->8B-S-000 544	3	19	490	OZA446-E11	1898	0412
Coupe Quattro	ABC	2.6	110	08.94-	8B-S-000 545->	3	19	710	OZA446-E50	0204	0412
Coupe	ABC	2.6	110	08.94-	8B-S-000 545->	3	19	710	OZA446-E50	0204	0412
Coupe Quattro	ABC	2.6	110	08.92-08.94		3	19	710	OZA446-E50	0204	0412
Coupe	ABC	2.6	110	08.92-08.94		3	19	710	OZA446-E50	0204	0412
Coupe	AAH	2.8	128	09.91-01.93	->8B-P-004 500	3	19	490	OZA446-E11	1898	0412
Coupe Quattro	AAH	2.8	128	01.93-	8B-P-004 501->	3	19	710	OZA446-E50	0204	0412
Coupe	AAH	2.8	128	01.93-	8B-P-004 501->	3	19	710	OZA446-E50	0204	0412
Quattro Quattro	RR	2.2	162	08.89-07.90		3	19	1215	OZA446-E16	1859	0412
Quattro Quattro	RR	2.2	162	08.90-07.91		3	19	975	OZA446-E2	1855	0412
S6	AAN	2.2	169	06.94-		3	19	975	OZA445-E7	0269	0412
S6	AAN	2.2	169	06.94-		3	19	975	OZA446-E2	1855	0412
V8	PT	3.6	184	10.88-11.93		3	19	975	OZA445-E7	0269	0412
V8	PT	3.6	184	08.91-11.93		3	19	975	OZA446-E2	1855	0412
V8	PT	3.6	184	10.88-11.93		3	19	975	OZA446-E2	1855	0412
V8	ABH	4.2	206	10.91-11.93		3	19	975	OZA445-E7	0269	0412
V8	ABH	4.2	206	10.91-11.93		3	19	975	OZA446-E2	1855	0412

AUTOBIANCHI

Y 10 1.0	156A2.146	1.0	33	10.87-07.89		3	19	670	OZA446-E1	1833	0412
Y 10 1.0	156A2.256	1.0	33	07.89-09.92		3	19	670	OZA446-E1	1833	0412
Y 10 1.1	156C046	1.1	37	07.89-09.92		3	19	895	OZA446-E4	1877	0412
Y 10 1.1	156C046	1.1	37	09.92-01.95		4	38	880	OZA527-E4	0218	1919
Y 10 1.1i.e. ECVT	176B2.000	1.1	40	02.95-12.95		4	40	972	OZA527-E7	0213	1919
Y 10 1.1i.e.	176B2.000	1.1	43	02.95-12.95		4	40	972	OZA527-E7	0213	1919
Y 10 1.3	146A5.046	1.3	53	02.89-09.92		3	19	895	OZA446-E4	1877	0412
Y 10 1.3	146A5.046 MPI	1.3	53	09.92-12.95		3	19	895	OZA446-E4	1877	0412
Y 10 1.3	146A5.046	1.3	54	11.87-06.89		3	19	895	OZA446-E4	1877	0412

BERTONE

Freeclimber 1.6	M40B16 BMW	1.6	74	02.92-		4	35	540	OZA572-E8	0209	1919
-----------------	------------	-----	----	--------	--	---	----	-----	-----------	------	------

BMW

116i	E87	N45B16	1.6	85	09.04-		4	54	591	OZA600-BM2	1845	---
116i	E87	N45B16	1.6	85	09.04-		4	54	431	OZA600-BM5	1846	---
120i	E87	N46B20 OL	2.0	110	06.04-	/ Cyl. 1+4	4	54	431	OZA600-BM5	1846	---
120i	E87	N46B20 OL	2.0	110	06.04-10.04	/ Cyl. 2+3	4	54	241	OZA600-BM7	1847	---
316g Compact	E36	M43B16	1.6	65-75	11.95-09.00		4	47	570	OZA572-E14	0408	1919
316g Compact	E36	M43B16	1.6	65-75	02.96-		4	47	350	OZA572-E6	1777	1919
316i Touring	E30	M40B16	1.6	73	09.91-04.94		4	35	910	OZA572-E12	0273	1919
316i	E30	M40B16	1.6	73	09.88-04.94		4	35	910	OZA572-E12	0273	1919
316i	E36	M40B16	1.6	73-75	12.90-02.94		4	35	540	OZA572-E8	0209	1919
316i	E36	M40B16 (Kat.)	1.6	73	09.90-	Siemens	4	54	968	OTA7N-5D3	1991	---
316 Ci Coupe	E46	M43B16	1.6	75	10.99-		4	68	340	OZA447-E28	0427	1952

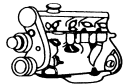

e kW



① ② ③

ORDER
STOCK
 No. No. L.No.
BMW

316g Compact	E36		1.6	75	12.95-	Siemens	4	54	968	OTA7N-5D3	1991	---
316i Touring	E36	M43B16	1.6	75	01.96-	Siemens	4	54	968	OTA7N-5D3	1991	---
316i	E36		1.6	75	09.90-	Siemens	4	54	968	OTA7N-5D3	1991	---
316i Compact	E36	M40B16	1.6	75	03.94-	Siemens	4	54	968	OTA7N-5D3	1991	---
316i	E36	M43B16	1.6	75	07.93-	Siemens	4	54	968	OTA7N-5D3	1991	---
316i Coupe	E36	M43B16	1.6	75	09.93-	Siemens	4	54	968	OTA7N-5D3	1991	---
316i	E36	M43B16	1.6	75	09.93-12.98		4	47	570	OZA572-E14	0408	1919
316i Compact	E36	M43B16	1.6	75	10.95-09.00		4	47	570	OZA572-E14	0408	1919
316i Coupe	E36	M43B16	1.6	75	09.93-12.99		4	47	570	OZA572-E14	0408	1919
316i Compact	E36	M43B16	1.6	75	03.94-09.95		4	35	540	OZA572-E8	0209	1919
316i	E36	M43B16	1.6	75	09.93-09.95		4	35	540	OZA572-E8	0209	1919
316i	E46	M43B16	1.6	75	04.98-		4	68	340	OZA447-E28	0427	1952
316i Compact	E36	M43B18	1.6	77	01.99-09.00		4	68	340	OZA447-E28	0427	1952
316i	E46	M43B18	1.6	77	04.98-		4	68	340	OZA447-E28	0427	1952
316i Compact	E36		1.9	77	12.98-	Siemens	4	54	968	OTA7N-5D3	1991	---
318i	E36	M40B18 (Kat.)	1.8	83	12.90-	Siemens	4	54	968	OTA7N-5D3	1991	---
318i	E30	M40B18	1.8	83-85	04.89-04.94		4	35	910	OZA572-E12	0273	1919
318i	E36	M40B18	1.8	83-85	12.90-02.94		4	35	540	OZA572-E8	0209	1919
318i	E36	M43B18	1.8	85	10.95-12.98		4	47	570	OZA572-E14	0408	1919
318i Cabrio	E36	M43B18	1.8	85	01.94-12.99		4	47	570	OZA572-E14	0408	1919
318i Touring	E36	M43B18	1.8	85	07.95-12.99		4	47	570	OZA572-E14	0408	1919
318i	E36	M43B18	1.8	85	09.93-09.95		4	35	540	OZA572-E8	0209	1919
318i Cabrio	E36	M43B18	1.8	85	01.94-	Siemens	4	54	968	OTA7N-5D3	1991	---
318i Touring	E36	M43B18	1.8	85	07.95-	Siemens	4	54	968	OTA7N-5D3	1991	---
318i	E36	M43B18	1.8	85	10.93-	Siemens	4	54	968	OTA7N-5D3	1991	---
318iS	E30	M42B18	1.8	100	09.89-08.90		4	35	730	OZA572-E3	0264	1919
318iS	E36	M42B18	1.8	100-103	09.93-12.98		4	35	540	OZA572-E8	0209	1919
318is Coupe	E36	M42B18	1.8	103	03.92-	Siemens	4	54	968	OTA7N-5D3	1991	---
318is	E36	M42B18	1.8	103	03.93-	Siemens	4	54	968	OTA7N-5D3	1991	---
318ti Compact	E36	M42B18	1.8	103	11.94-	Siemens	4	54	968	OTA7N-5D3	1991	---
318iS Coupe	E36	M42B18	1.8	103	03.92-12.98		4	35	540	OZA572-E8	0209	1919
318ti Compact	E36	M42B18	1.8	103	10.94-11.95		4	35	540	OZA572-E8	0209	1919
318 Ci Coupe	E46	M43B18	1.9	87	04.99-		4	68	340	OZA447-E28	0427	1952
318i	E46	M43B18	1.9	87	04.98-		4	68	340	OZA447-E28	0427	1952
318i Touring	E46	M43B18	1.9	87	10.99-		4	68	340	OZA447-E28	0427	1952
318is Coupe	E36	M44B19	1.9	103	09.95-	Siemens	4	54	968	OTA7N-5D3	1991	---
318is	E36	M44B19	1.9	103	09.95-	Siemens	4	54	968	OTA7N-5D3	1991	---
318ti Compact	E36	M44B19	1.9	103	07.95-	Siemens	4	54	968	OTA7N-5D3	1991	---
318iS Coupe	E36	M44B19	1.9	103	12.95-12.99		4	68	340	OZA447-E28	0427	1952
318iS	E36	M44B19	1.9	103	09.94-12.98		4	68	340	OZA447-E28	0427	1952
318ti Compact	E36	M44B19	1.9	103	12.95-09.00		4	68	340	OZA447-E28	0427	1952
320i	E30	M20B20	2.0	90-95	10.87-03.93		4	35	510	OZA572-E2	0252	1919
320 Ci Coupe	E46	M52B20	2.0	110	04.98-		4	68	290	OZA447-E27	0416	1952
320 Ci Coupe	E46	M52B20	2.0	110	04.98-		4	69	975	OZA447-E29	0438	1952
320i	E36	M50B (20 6 S2) Vanos	2.0	110	09.90-	Siemens	4	54	968	OTA7N-5D3	1991	---
320i Coupe	E36	M50B (20 6 S2) Vanos	2.0	110	03.92-	Siemens	4	54	968	OTA7N-5D3	1991	---
320i Touring	E36	M52B (20 6 S3) Vanos	2.0	110	01.95-	Siemens	4	54	968	OTA7N-5D3	1991	---
320i Cabrio	E36	M52B (20 6 S3) Vanos	2.0	110	12.93-	Siemens	4	54	968	OTA7N-5D3	1991	---
320i	E36	M52B20	2.0	110	09.92-08.94		4	52	398	OTA7H-3A2	1943	---
320i	E36	M52B20	2.0	110	09.95-09.99		4	54	968	OTA7H-5A1	0486	---
320i	E36	M50B20	2.0	110	09.90-08.92		4	35	400	OZA572-E5	0242	1919
320i	E36	M50B20	2.0	110	09.90-08.92		4	35	540	OZA572-E8	0209	1919

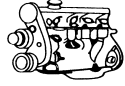

ℓ kW



① ② ③

ORDER
STOCK
 No. No.
BMW

320i	E36	M50B20	2.0	110	09.92-12.95	/ Siemens	4	52	238	OTA7N-5B1	1973	---
320i Coupe	E36	M50B20	2.0	110	09.92-12.95	/ Siemens	4	52	238	OTA7N-5B1	1973	---
320i Cabrio	E36	M50B20	2.0	110	12.93-12.95	/ Siemens	4	52	238	OTA7N-5B1	1973	---
320i	E36	M52B20	2.0	110	09.94-09.95	/ Siemens	4	47	968	OTA7N-5C1	1963	---
320i Coupe	E36	M52B20	2.0	110	09.94-09.95	/ Siemens	4	47	968	OTA7N-5C1	1963	---
320i Cabrio	E36	M52B20	2.0	110	09.94-09.95	/ Siemens	4	47	968	OTA7N-5C1	1963	---
320i Touring	E36	20 6 S3	2.0	110	01.95-09.95	/ Siemens	4	47	968	OTA7N-5C1	1963	---
320i	E46	M52B20	2.0	110	03.98-		4	68	290	OZA447-E27	0416	1952
320i	E46	M52B20	2.0	110	04.98-		4	69	975	OZA447-E29	0438	1952
320i Touring	E46	M52B20	2.0	110	10.99-		4	68	290	OZA447-E27	0416	1952
320i Touring	E46	M52B20	2.0	110	10.99-		4	69	975	OZA447-E29	0438	1952
320i Touring	E46	M54	2.2	125	09.00-		4	68	290	OZA447-E27	0416	1952
320i Touring	E46	M54	2.2	125	09.00-		4	69	975	OZA447-E29	0438	1952
320i	E46	M54	2.2	125	09.00-		4	68	290	OZA447-E27	0416	1952
320i	E46	M54	2.2	125	09.00-		4	69	975	OZA447-E29	0438	1952
320 Ci Cabrio	E46	M54	2.2	125	09.00-		4	68	290	OZA447-E27	0416	1952
320 Ci Coupe	E46	M54	2.2	125	09.00-		4	68	290	OZA447-E27	0416	1952
320 Ci Coupe	E46	M54	2.2	125	09.00-		4	69	975	OZA447-E29	0438	1952
320 Ci Cabrio	E46	M54	2.2	125	09.00-		4	69	975	OZA447-E29	0438	1952
323 Ci Cabrio	E46	M52B25	2.5	125	03.00-09.00		4	68	290	OZA447-E27	0416	1952
323 Ci Cabrio	E46	M52B25	2.5	125	03.00-09.00		4	69	975	OZA447-E29	0438	1952
323 Ci Coupe	E46	M52B25	2.5	125	04.98-09.00		4	68	290	OZA447-E27	0416	1952
323 Ci Coupe	E46	M52B25	2.5	125	04.98-09.00		4	69	975	OZA447-E29	0438	1952
323i	E36	M52B25 (Vanos)	2.5	125	03.95-	Siemens	4	54	968	OTA7N-5D3	1991	---
323i Coupe	E36	M52B25 (Vanos)	2.5	125	03.95-	Siemens	4	54	968	OTA7N-5D3	1991	---
323i Touring	E36	M52B25 (Vanos)	2.5	125	09.95-	Siemens	4	54	968	OTA7N-5D3	1991	---
323i Cabrio	E36	M52B25 (Vanos)	2.5	125	06.95-	Siemens	4	54	968	OTA7N-5D3	1991	---
323ti Compact	E36	M52B25 (Vanos)	2.5	125	08.97-	Siemens	4	54	968	OTA7N-5D3	1991	---
323i	E36	M52B25	2.5	125	06.95-09.99	Siemens	4	54	968	OTA7H-5A1	0486	---
323i	E36	M52B25	2.5	125	06.95-09.95	/ Siemens	4	47	968	OTA7N-5C1	1963	---
323i Coupe	E36	M52B25	2.5	125	06.95-09.95	/ Siemens	4	47	968	OTA7N-5C1	1963	---
323i Cabrio	E36	M52B25	2.5	125	06.95-09.95	/ Siemens	4	47	968	OTA7N-5C1	1963	---
323i	E46	M52B25	2.5	125	03.98-09.00		4	68	290	OZA447-E27	0416	1952
323i	E46	M52B25	2.5	125	04.98-09.00		4	69	975	OZA447-E29	0438	1952
323i Touring	E46	M52B25	2.5	125	08.98-09.00		4	68	290	OZA447-E27	0416	1952
323ti Compact	E36	M52B25	2.5	125	01.99-08.00	Siemens	4	54	388	OTA7N-5D1	1974	---
325i	E30	M20B25	2.5	125	10.87-10.93		4	35	510	OZA572-E2	0252	1919
325 Ci Coupe	E46	25 6 S5	2.5	141	09.00-		4	68	290	OZA447-E27	0416	1952
325 Ci Coupe	E46	25 6 S5	2.5	141	09.00-		4	69	975	OZA447-E29	0438	1952
325 Ci Cabrio	E46	25 6 S5	2.5	141	09.00-		4	68	290	OZA447-E27	0416	1952
325 Ci Cabrio	E46	25 6 S5	2.5	141	09.00-		4	69	975	OZA447-E29	0438	1952
325i	E36	M52B25 (Vanos)	2.5	141	09.90-	Siemens	4	54	968	OTA7N-5D3	1991	---
325i Coupe	E36	M52B25 (Vanos)	2.5	141	03.92-	Siemens	4	54	968	OTA7N-5D3	1991	---
325i Cabrio	E36	M52B25 (Vanos)	2.5	141	03.93-	Siemens	4	54	968	OTA7N-5D3	1991	---
325 Xi	E46	25 6 S5	2.5	141	09.00-		4	68	290	OZA447-E27	0416	1952
325 Xi	E46	25 6 S5	2.5	141	09.00-		4	69	975	OZA447-E29	0438	1952
325 Xi Touring	E46	25 6 S5	2.5	141	09.00-		4	68	290	OZA447-E27	0416	1952
325 Xi Touring	E46	25 6 S5	2.5	141	09.00-		4	69	975	OZA447-E29	0438	1952
325i	E36	M50B25	2.5	141	09.90- 98		4	35	400	OZA572-E5	0242	1919
325i	E36	M50B25	2.5	141	09.90- 98		4	35	540	OZA572-E8	0209	1919
325i	E46	25 6 S5	2.5	141	09.00-		4	68	290	OZA447-E27	0416	1952
325i Touring	E46	25 6 S5	2.5	141	09.00-		4	68	290	OZA447-E27	0416	1952

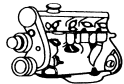

ℓ kW



① ② ③

ORDER No. STOCK No. L.No.

BMW

325i	E46	25 6 S5	2.5	141	09.00-		4	69	975	OZA447-E29	0438	1952
325i Touring	E46	25 6 S5	2.5	141	09.00-		4	69	975	OZA447-E29	0438	1952
325e	E30	M20B27	2.7	90-95	10.87-09.90		4	35	540	OZA572-E8	0209	1919
328 Ci Coupe	E46	M52B28	2.8	142	04.98-09.00		4	68	290	OZA447-E27	0416	1952
328 Ci Coupe	E46	M52B28	2.8	142	04.98-09.00		4	69	975	OZA447-E29	0438	1952
328i Touring	E36	M52B28	2.8	142	01.95-	Siemens	4	54	968	OTA7N-5D3	1991	---
328i Coupe	E36	M52B28	2.8	142	01.95-	Siemens	4	54	968	OTA7N-5D3	1991	---
328i Cabrio	E36	M52B28	2.8	142	03.95-	Siemens	4	54	968	OTA7N-5D3	1991	---
328i	E36	M52B28	2.8	142	01.95-	Siemens	4	54	968	OTA7N-5D3	1991	---
328i	E36	M52B28	2.8	142	01.95-09.99	Siemens	4	54	968	OTA7H-5A1	0486	---
328i	E36	M52B28	2.8	142	01.95-09.95	/ Siemens	4	47	968	OTA7N-5C1	1963	---
328i Coupe	E36	M52B28	2.8	142	01.95-09.95	/ Siemens	4	47	968	OTA7N-5C1	1963	---
328i Cabrio	E36	M52B28	2.8	142	03.95-09.95	/ Siemens	4	47	968	OTA7N-5C1	1963	---
328i Touring	E36	M52B28	2.8	142	01.95-09.95	/ Siemens	4	47	968	OTA7N-5C1	1963	---
328i Touring	E46	M52B28	2.8	142	10.99-09.00		4	68	290	OZA447-E27	0416	1952
328i	E46	M52B28	2.8	142	04.98-09.00		4	68	290	OZA447-E27	0416	1952
328i	E46	M52B28	2.8	142	04.98-09.00		4	69	975	OZA447-E29	0438	1952
328i Touring	E46	M52B28	2.8	142	10.99-09.00		4	69	975	OZA447-E29	0438	1952
330 Ci Cabrio	E46	30 6 S3	3.0	170	05.00-		4	68	290	OZA447-E27	0416	1952
330 Ci Cabrio	E46	30 6 S3	3.0	170	05.00-		4	69	975	OZA447-E29	0438	1952
330 Ci Coupe	E46	30 6 S3	3.0	170	05.00-		4	68	290	OZA447-E27	0416	1952
330 Ci Coupe	E46	30 6 S3	3.0	170	05.00-		4	69	975	OZA447-E29	0438	1952
330 Xi Touring	E46	30 6 S3	3.0	170	07.00-		4	68	290	OZA447-E27	0416	1952
330 Xi Touring	E46	30 6 S3	3.0	170	07.00-		4	69	975	OZA447-E29	0438	1952
330 Xi	E46	30 6 S3	3.0	170	07.00-		4	68	290	OZA447-E27	0416	1952
330 Xi	E46	30 6 S3	3.0	170	07.00-		4	69	975	OZA447-E29	0438	1952
330i	E46	30 6 S3	3.0	170	05.00-		4	68	290	OZA447-E27	0416	1952
330i	E46	30 6 S3	3.0	170	05.00-		4	69	975	OZA447-E29	0438	1952
330i Touring	E46	30 6 S3	3.0	170	05.00-		4	69	975	OZA447-E29	0438	1952
330i Touring	E46	30 6 S3	3.0	170	05.00-		4	68	290	OZA447-E27	0416	1952
518g Touring	E34	M43B18	1.8	75-85	11.95-12.95		4	35	910	OZA572-E12	0273	1919
518i	E34	M40B18	1.8	83-85	09.89-12.95		4	35	910	OZA572-E12	0273	1919
518i	E34	M40B18	1.8	83-85	09.91-12.95		4	35	910	OZA572-E12	0273	1919
518i Touring	E34	M43B18	1.8	85	12.93-12.95		4	35	910	OZA572-E12	0273	1919
518i Touring	E34	M40B18	1.8	83-85	03.93-12.95		4	35	910	OZA572-E12	0273	1919
518i	E34	M43B18	1.8	85	12.93-12.95		4	35	910	OZA572-E12	0273	1919
520i	E34	M20B20	2.0	95	01.88-08.91		4	59	675	OZA447-E10	0138	1952
520i	E34	M50B20	2.0	110	09.92-08.95		4	52	1408	OTA7H-3A1	1932	---
520i	E34	M50B20	2.0	110	09.89-06.92		4	35	1420	OZA572-E4	0295	1919
520i	E39	M52B20	2.0	110	02.96-09.99	Siemens	4	54	968	OTA7H-5A1	0486	---
520i	E39	M52B20	2.0	110	09.95-09.00		4	68	290	OZA447-E27	0416	1952
520i	E39	M52B20	2.0	110	09.95-09.00		4	69	975	OZA447-E29	0438	1952
520i Touring	E39	M52B20	2.0	110	12.96-09.00		4	68	290	OZA447-E27	0416	1952
520i Touring	E39	M52B20	2.0	110	12.96-09.00		4	69	975	OZA447-E29	0438	1952
520i Touring	E39	M54	2.2	125	09.00-		4	68	290	OZA447-E27	0416	1952
520i	E39	M54	2.2	125	09.00-		4	68	290	OZA447-E27	0416	1952
520i	E39	M54	2.2	125	09.00-		4	69	975	OZA447-E29	0438	1952
520i Touring	E39	M54	2.2	125	09.00-		4	69	975	OZA447-E29	0438	1952
523i	E39	M52B25	2.5	125	09.95-09.99	Siemens	4	54	968	OTA7H-5A1	0486	---
523i	E39	M52B25	2.5	125	09.95-09.00		4	68	290	OZA447-E27	0416	1952
523i	E39	M52B25	2.5	125	09.95-09.00		4	69	975	OZA447-E29	0438	1952
523i Touring	E39	M52B25	2.5	125	12.96-09.00		4	68	290	OZA447-E27	0416	1952

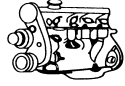

ℓ kW



① ② ③

ORDER
No. No.
STOCK
No. No.
SINCE
1981
L. No.**BMW**

523i Touring	E39	M52B25	2.5	125	01.97-09.00		4	69	975	OZA447-E29	0438	1952
525i	E34	M50B25	2.5	125	01.88-08.91		4	59	675	OZA447-E10	0138	1952
525i	E34	M50B25	2.5	141	09.89-12.95		4	35	1420	OZA572-E4	0295	1919
525i	E39	25 6 S5	2.5	141	09.00-		4	68	290	OZA447-E27	0416	1952
525i	E39	25 6 S5	2.5	141	09.00-		4	69	975	OZA447-E29	0438	1952
525i Touring	E39	25 6 S5	2.5	141	09.00-		4	68	290	OZA447-E27	0416	1952
525i Touring	E39	25 6 S5	2.5	141	09.00-		4	69	975	OZA447-E29	0438	1952
528i	E39	M52B28	2.8	142	09.95-09.99	Siemens	4	54	968	OTA7H-5A1	0486	- - -
528i	E39	M52B28	2.8	142	09.95-09.00		4	68	290	OZA447-E27	0416	1952
528i	E39	M52B28	2.8	142	09.95-09.00		4	69	975	OZA447-E29	0438	1952
528i Touring	E39	M52B28	2.8	142	01.97-09.00		4	68	290	OZA447-E27	0416	1952
528i Touring	E39	M52B28	2.8	142	01.97-09.00		4	69	975	OZA447-E29	0438	1952
530i	E34	M30B30	3.0	138	01.88-02.90		4	35	1490	OZA527-E27	0466	1919
530i	E34	M60B30	3.0	160	09.92-06.94		4	35	540	OZA572-E8	0209	1919
530i	E34	M60B30	3.0	160	09.92-06.94		4	35	540	OZA572-E8	0209	1919
530i	E39	30 6 S3	3.0	170	09.00-		4	68	290	OZA447-E27	0416	1952
530i	E39	30 6 S3	3.0	170	09.00-		4	69	975	OZA447-E29	0438	1952
530i Touring	E39	30 6 S3	3.0	170	09.00-		4	68	290	OZA447-E27	0416	1952
530i Touring	E39	30 6 S3	3.0	170	09.00-		4	69	975	OZA447-E29	0438	1952
535i	E34	M30B35	3.4	155	01.88-12.93		4	35	1490	OZA527-E27	0466	1919
535i	E39	M62B35	3.5	173-180	01.96-		4	68	340	OZA447-E28	0427	1952
540i	E34	M60B40	4.0	210	09.92-07.93		4	35	540	OZA572-E8	0209	1919
540i	E34	M60B40	4.0	210	09.92-06.94		4	35	540	OZA572-E8	0209	1919
540i	E39	M62B44	4.4	210	01.96-		4	68	290	OZA447-E27	0416	1952
540i Touring	E39	M62B44	4.4	210	10.98-		4	68	290	OZA447-E27	0416	1952
540i Touring	E39	M62B44	4.4	210	-09.98		4	68	340	OZA447-E28	0427	1952
540i	E39	M62B44	4.4	210	01.96-		4	68	340	OZA447-E28	0427	1952
635 CSI	E24	M30B35	3.4	136	01.85-05.89		4	35	1490	OZA527-E27	0466	1919
635 CSI	E24	M30B35	3.4	141	04.85-09.90		4	35	1490	OZA527-E27	0466	1919
635 CSI	E24	M30B35	3.4	155	08.87-05.89		4	35	1490	OZA527-E27	0466	1919
728i	E38	M52B28	2.8	141	09.95-09.99	Siemens	4	54	968	OTA7H-5A1	0486	- - -
728i, iL	E38	M52B28	2.8	142	10.98-		4	68	290	OZA447-E27	0416	1952
728i, iL	E38	M52B28	2.8	142	09.95-		4	69	975	OZA447-E29	0438	1952
730i, iL	E32	M30B30	3.0	138	12.86-09.94		4	35	1490	OZA527-E27	0466	1919
730i, iL	E32	M30B30	3.0	145	12.86-09.94		4	35	1490	OZA527-E27	0466	1919
730i, iL	E38	M60B30	3.0	155	10.94-		4	47	570	OZA572-E14	0408	1919
730i	E32	M60B30	3.0	160	04.92-10.94		4	35	540	OZA572-E8	0209	1919
730i	E32	M60B30	3.0	160	04.92-10.94		4	35	540	OZA572-E8	0209	1919
730i, iL	E38	M60B30	3.0	160	10.94-		4	47	570	OZA572-E14	0408	1919
735i, iL	E32	M30B35	3.4	155	09.86-09.92		4	35	1490	OZA527-E27	0466	1919
735i, iL	E32	M30B35	3.4	162	09.86-12.87		4	35	1490	OZA527-E27	0466	1919
735i, iL	E38	M62B35	3.5	173	09.94-		4	68	340	OZA447-E28	0427	1952
735i, iL	E38	M62B35	3.5	175	09.94-		4	68	290	OZA447-E27	0416	1952
740i	E32	M60B40	4.0	210	04.92-10.94		4	35	540	OZA572-E8	0209	1919
740i, iL	E38	M60B40	4.0	210	10.94-12.95		4	47	570	OZA572-E14	0408	1919
740i, iL	E38	M62B44	4.4	210	10.98-		4	68	290	OZA447-E27	0416	1952
740i, iL	E38	M62B44	4.4	210	01.96-09.98		4	68	340	OZA447-E28	0427	1952
750i	E32	M70B50	5.0	220	09.87-10.94		4	35	540	OZA572-E8	0209	1919
750i, iL	E38	M73B54	5.4	240	06.94-		4	68	290	OZA447-E27	0416	1952
840 Ci	E31	M60B40	4.0	210	04.93-09.93		4	47	350	OZA572-E6	1777	1919
840 Ci	E31	M60B40	4.0	210	04.93-		4	35	540	OZA572-E8	0209	1919
840 Ci	E31	M62B44	4.4	210	09.94-12.99		4	68	340	OZA447-E28	0427	1952

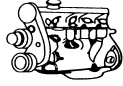

e kW



① ② ③

ORDER
STOCK
 No. No. L.No.
BMW

850 Ci	E31	M70B50	5.0	220	04.90-12.94		4	35	540	OZA572-E8	0209	1919
850 CSI	E31	M70B56	5.6	280	08.92-10.96		4	35	910	OZA572-E12	0273	1919
850 Ci	E31	M73B54	5.4	240	03.94-12.99		4	68	290	OZA447-E27	0416	1952
M3	E36	S50B30	3.0	210	01.94-12.95		4	35	540	OZA572-E8	0209	1919
M3 Coupe	E36	S 50 B 30	3.0	210	10.92-	Siemens	4	54	968	OTA7N-5D3	1991	---
M3 Cabriolet	E36	S 50 B 30	3.0	210	01.94-	Siemens	4	54	968	OTA7N-5D3	1991	---
M3	E36	S 50 B 30	3.0	210	08.94-	Siemens	4	54	968	OTA7N-5D3	1991	---
M3 Coupe	E36	S 50 B 30	3.0	217	01.95-	Siemens	4	54	968	OTA7N-5D3	1991	---
M3	E36	S 50 B 32	3.2	236	09.95-	Siemens	4	54	968	OTA7N-5D3	1991	---
M3 Cabriolet	E36	S 50 B 32	3.2	236	10.95-	Siemens	4	54	968	OTA7N-5D3	1991	---
M3 Coupe	E36	S 50 B 32	3.2	236	10.95-	Siemens	4	54	968	OTA7N-5D3	1991	---
M5	E34	S38 B36	3.5	232	10.88-12.92		4	35	1490	OZA527-E27	0466	1919
M5	E34	S38 B36	3.8	250	03.92-12.95		4	35	1490	OZA527-E27	0466	1919
M5 Touring	E34	S38 B36	3.8	250	04.92-12.95		4	35	1490	OZA527-E27	0466	1919
M5	E39	50 8 S1	5.0	294	10.98-		4	68	290	OZA447-E27	0416	1952
X5 3.0i	E53	30 6 S8	3.0	170	10.99-		4	68	290	OZA447-E27	0416	1952
X5 3.0i	E53	30 6 S3	3.0	170	10.99-		4	69	975	OZA447-E29	0438	1952
X5 4.4i	E53	44 8 S2	4.4	210	10.98-		4	68	290	OZA447-E27	0416	1952
X5 4.4i	E53	44 8 S2	4.4	210	10.98-		4	69	975	OZA447-E29	0438	1952
Z1	Z/B	M20B25	2.5	125	11.88-06.91		4	35	510	OZA572-E2	0252	1919
Z3	E36/7	M43B18	1.8	85	10.95-		4	47	570	OZA572-E14	0408	1919
Z3	E36/7	M43B18	1.9	87	09.98-		4	68	340	OZA447-E28	0427	1952
Z3	E36/7	M43B18	1.9	103	09.95-12.99		4	68	340	OZA447-E28	0427	1952
Z3	E36/7	M52B25	2.0	110	04.99-12.00		4	68	290	OZA447-E27	0416	1952
Z3	E36/7	20 6 S4	2.0	110	04.99-12.00		4	69	975	OZA447-E29	0438	1952
Z3	E36/7	M54	2.2	125	09.00-		4	68	290	OZA447-E27	0416	1952
Z3	E36/7	M54	2.2	125	09.00-		4	69	975	OZA447-E29	0438	1952
Z3 Coupe	E36/7	M 52 B 28	2.8	141	07.97-	Siemens	4	53	708	OTA7N-5E1	1965	---
Z3 Cabriolet	E36/7	M 52 B 28	2.8	141	04.97-	Siemens	4	53	708	OTA7N-5E1	1965	---
Z3	E36/7	M52B28	2.8	141	04.97-09.98	Siemens	4	54	388	OTA7N-5D1	1974	---
Z3 Coupe	E36/7	M52B28	2.8	141	07.97-09.98	Siemens	4	54	388	OTA7N-5D1	1974	---
Z3	E36/7	M52B28	2.8	142	11.96-09.00		4	68	290	OZA447-E27	0416	1952
Z3 Coupe	E36/7	M52B28	2.8	142	09.97-09.00		4	68	290	OZA447-E27	0416	1952
Z3 Coupe	E36/7	M52B28	2.8	142	09.97-09.00		4	69	975	OZA447-E29	0438	1952
Z3	E36/7	M52B28	2.8	142	11.96-09.00		4	69	975	OZA447-E29	0438	1952
Z3 Coupe	E36/7	30 6 S3	3.0	170	05.00-		4	68	290	OZA447-E27	0416	1952
Z3	E36/7	30 6 S3	3.0	170	05.00-		4	68	290	OZA447-E27	0416	1952
Z3 Coupe	E36/7	30 6 S3	3.0	170	05.00-		4	69	975	OZA447-E29	0438	1952
Z3	E36/7	30 6 S3	3.0	170	05.00-		4	69	975	OZA447-E29	0438	1952
Z3 M Coupe	E36/7	S52 (M3)	3.2	236	02.98-	Siemens / USA	4	54	638	OTA7N-5D2	1975	---
Z3 M Cabriolet	E36/7	S52 (M3)	3.2	236	03.97-	Siemens / USA	4	54	638	OTA7N-5D2	1975	---
Z3 M Coupe	E36/7	S52 (M3)	3.3	239	06.01-	Siemens / USA	4	54	638	OTA7N-5D2	1975	---
Z3 M Cabriolet	E36/7	S52 (M3)	3.3	239	06.01-	Siemens / USA	4	54	638	OTA7N-5D2	1975	---
Z8	E52	50 8 S1	5.0	294	03.00-		4	68	290	OZA447-E27	0416	1952

CHEVROLET

Cavallier			2.0				4	86	247	OZA531-GM7	1870	---
Corvette 5.7i		8 TPI	5.7	179-183	08.88-08.91		3	14	375	OZA446-E8	1827	0412
Corvette 5.7i Convertible		P TPI	5.7	225	09.91-08.93		3	14	375	OZA446-E8	1827	0412
Corvette 5.7i ZR-1		LT5 MFI	5.7	279	06.89-08.91		3	14	375	OZA446-E8	1827	0412
Corvette 5.7i ZR-1		LT5 J SFI	5.7	279-302	09.91-08.93		3	14	375	OZA446-E8	1827	0412

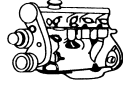

ℓ kW



① ② ③

STOCK
REVISION
L. No.
ORDER
No. No.**CHRYSLER**

Cirrus 2.5i 24V	EEB	2.5	118	09.96-12.00		3	19	490	OZA446-E11	1898	0412
Cirrus 2.5i 24V	EEO	2.5	118	09.96-12.00		3	19	490	OZA446-E11	1898	0412
Convertible 2.5i 24V	EEB	2.5	118	01.98-12.00		3	19	490	OZA446-E11	1898	0412
Convertible 2.5i 24V	EEO	2.5	118	01.98-12.00		3	19	490	OZA446-E11	1898	0412
Sebring 2.5i 24V Cabrio	EEB	2.5	122	01.00-12.00		3	19	490	OZA446-E11	1898	0412
Sebring 2.5i 24V Cabrio	EEO	2.5	122	01.00-12.00		3	19	490	OZA446-E11	1898	0412
Sebring 2.5i 24V Cabrio	EER	2.5	122	01.00-12.00		3	19	490	OZA446-E11	1898	0412
Stratus 2.5i 24V	EEB	2.5	118	01.98-12.99		3	19	490	OZA446-E11	1898	0412
Stratus 2.5i 24V	EEO	2.5	118	01.98-12.99		3	19	490	OZA446-E11	1898	0412
Stratus 2.5i 24V Cabrio	EEB	2.5	120	01.98-12.99		3	19	490	OZA446-E11	1898	0412
Stratus 2.5i 24V Cabrio	EEO	2.5	120	01.98-12.99		3	19	490	OZA446-E11	1898	0412

CITROEN

AX 1.0i	CDY <TU9M>	1.0	31-33	02.95-	Org. N. 6630->	4	49	1220	OZA527-E17	0445	1919
AX 1.0i	CDY <TU9M>	1.0	31-33	07.92-01.95	Org. N. ->6629	4	58	1470	OZA527-E3	0201	1919
AX 1.0i	CDZ <TU9M>	1.0	37	02.95-	Org. N. 6630->	4	49	1220	OZA527-E17	0445	1919
AX 1.0i	CDZ <TU9M>	1.0	37	07.92-01.95	Org. N. ->6629	4	58	1470	OZA527-E3	0201	1919
AX 1.1i	HDZ <TU1M>	1.1	40-44	10.89-05.91	Org. N. ->5292	4	37	1210	OZA527-E22	0274	1919
AX 1.1i	HDZ <TU1M>	1.1	40-44	06.91-04.92	Org. N. 5293->6629	4	58	1470	OZA527-E3	0201	1919
AX 1.1i	HDY <TU1M>	1.1	44	02.95-	Org. N. 6630->	4	49	1220	OZA527-E17	0445	1919
AX 1.1i	HDY <TU1M>	1.1	44	05.92-01.95	Org. N. 5293->6629	4	58	1470	OZA527-E3	0201	1919
AX 1.4i	KDX <TU3FM>	1.4	55	02.95-	Org. N. 6630->	4	49	1220	OZA527-E17	0445	1919
AX 1.4i	KDX <TU3FM>	1.4	55	01.93-01.95	Org. N. 5293->6629	4	58	1470	OZA527-E3	0201	1919
AX 1.4i	KDY <TU3M>	1.4	55-58	02.95-	Org. N. 6630->	4	49	1220	OZA527-E17	0445	1919
AX 1.4i	KDY <TU3M>	1.4	55-58	06.90-05.91	Org. N. ->5292	4	37	1210	OZA527-E22	0274	1919
AX 1.4i	KDY <TU3M>	1.4	55-58	06.91-01.95	Org. N. 5293->6629	4	58	1470	OZA527-E3	0201	1919
AX 1.4i	KDY <TU3FM>	1.4	55-58	02.95-	Org. N. 6630->	4	49	1220	OZA527-E17	0445	1919
AX 1.4i	KDY <TU3FM>	1.4	55-58	-05.91	Org. N. ->5292	4	37	1210	OZA527-E22	0274	1919
AX 1.4i	KDY <TU3FM>	1.4	55-58	06.91-01.95	Org. N. 5293->6629	4	58	1470	OZA527-E3	0201	1919
AX 1.4i	KDZ <TU3M>	1.4	58	06.88-05.90	Org. N. ->5292	4	37	1210	OZA527-E22	0274	1919
AX 1.4i	KFY <TU3FJ>	1.4	66	02.95-	Org. N. 6630->	4	49	1220	OZA527-E17	0445	1919
AX 1.4i	KFY <TU3FJ>	1.4	66	05.91-01.95	Org. N. ->6629	4	58	450	OZA527-E12	0220	1919
AX 1.4i	KFZ <TU3FJ>	1.4	69-70	05.91-01.95	Org. N. ->6629	4	58	450	OZA527-E12	0220	1919
AX 1.4i	KFZ <TU3FJ>	1.4	69-70	02.95-	Org. N. 6630->	4	49	1220	OZA527-E17	0445	1919
AX 1.4i	K6B <TU3FJ>	1.4	70-74	05.91-01.95	Org. N. ->6629	4	58	450	OZA527-E12	0220	1919
AX 1.4i	K6B <TU3FJ>	1.4	70-74	02.95-	Org. N. 6630->	4	49	1220	OZA527-E17	0445	1919
Berlingo 1.1i	HDZ	1.1	44	12.98-		3	19	975	OZA446-E2	1855	0412
Berlingo 1.1i	HDY	1.1	44	12.98-		3	19	975	OZA446-E2	1855	0412
Berlingo 1.1i	HDY <TU1M+>	1.1	44	07.96-		4	49	380	OZA448-E57	0492	1952
Berlingo 1.1i	HDY	1.1	44	07.96-11.98		4	49	375	OZA527-E15	0298	1919
Berlingo 1.1i	HDZ	1.1	44	07.96-11.98		4	49	375	OZA527-E15	0298	1919
Berlingo 1.1i	HFZ <TU1JP+>	1.1	44	06.00-	/ Euro 2000	4	82	536	OZA341-PG5	1813	1952
Berlingo 1.1i	HFZ <TU1JP+>	1.1	44	06.00-	/ Euro 2000	4	82	536	OZA341-PG5	1813	1952
Berlingo 1.4i	KFX <TU3JP>	1.4	55	07.96-06.98	Org. N. ->7874	4	49	380	OZA448-E57	0492	1952
Berlingo 1.4i	KFX <TU3JP>	1.4	55	07.96-12.99		4	73	370	OZA527-E29	0488	1919
Berlingo 1.4i	KFX <TU3JP+>	1.4	55	01.00-	/ Euro 2000	4	82	536	OZA341-PG5	1813	1952
Berlingo 1.4i	KFX <TU3JP+>	1.4	55	01.00-	Depol L4-CEE W4 / Euro 2000	4	82	536	OZA341-PG5	1813	1952
BX 14i	KDZ <TU3M/Z>	1.4	55	09.88-07.90		4	37	1210	OZA527-E22	0274	1919
BX 14i	KDY <TU3M/Z>	1.4	55	04.90-		4	37	1210	OZA527-E22	0274	1919
BX 16i	BDZ <XU5MZ>	1.6	65	05.89-10.91		4	37	1210	OZA527-E22	0274	1919

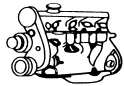

e kW



① ② ③

ORDER
STOCK
 No. No. L.No.
CITROEN

BX 16i Break	BDY <XU5M>	1.6	65	05.89-12.94		4	37	1210	OZA527-E22	0274	1919
BX 16i	BDY <XU5M>	1.6	65	07.91-		4	37	1210	OZA527-E22	0274	1919
BX 19i	DFZ <XU9J1/Z>	1.9	75-77	03.86-06.86		3	19	490	OZA446-E11	1898	0412
BX 19i	DFZ <XU9J1/Z>	1.9	75-77	07.86-		4	37	1210	OZA527-E22	0274	1919
BX 19i	DDZ <XU9M/Z>	1.9	80	06.88-		4	37	1210	OZA527-E22	0274	1919
BX 19i 4x4	DDZ <XU9M>	1.9	80	10.90-05.91		4	37	1210	OZA527-E22	0274	1919
BX 19i	DKZ <XU9JA/Z>	1.9	88	06.88-		4	37	1210	OZA527-E22	0274	1919
BX 19i 16S	DFW <XU9J4/Z>	1.9	108	03.88-		4	37	1210	OZA527-E22	0274	1919
C 15 1.1i	HDZ	1.1	44	06.89-04.92	Org. N. ->5656	4	37	1210	OZA527-E22	0274	1919
C 15 1.1i	HDZ	1.1	44	04.92-	Org. N. 5657->	4	58	1470	OZA527-E3	0201	1919
C 15 1.4i	KDY	1.4	55-58	04.92-	Org. N. 5657->	4	58	1470	OZA527-E3	0201	1919
C 16 1.4i	K1G <TU3A>	1.4	51	07.87-		4	37	1210	OZA527-E22	0274	1919
C 17 1.4i	KDY	1.4	55-58	01.92-04.92	Org. N. ->5656	4	37	1210	OZA527-E22	0274	1919
C5 1.8i 16V	6FZ <EW7J4>	1.8	85	01.01-02.01	/ Euro 2000	4	82	1236	OZA341-PG6	1814	1952
C5 1.8i 16V	6FZ <EW7J4>	1.8	85	02.01-	/ Euro 2000	4	82	1836	OZA341-PG8	1816	1952
C5 1.8i 16V	6FZ <EW7J4>	1.8	85	01.01-	Euro 2000	4	83	536	OZA495-PG2	1852	1952
C5 2.0 Hpi 16V	RLZ <EW10D>	2.0	105	07.01-		5	93	375	LZA06-U1	1840	- - -
C5 2.0 Hpi 16V	RLZ <EW10D>	2.0	105	07.01-09.01	/ Euro 2000	4	82	1236	OZA538-PG1	1818	1952
C5 2.0 Hpi 16V	RLZ <EW10D>	2.0	105	09.01-	/ Euro 2000	4	82	1836	OZA538-PG2	1819	1952
CX 25 Injection	M25-668 <EN5L>	2.5	89-98	05.86-12.92		4	37	1210	OZA527-E22	0274	1919
Evasion 1.8i	LFW <XU7JP>	1.8	73	09.96-		4	49	1480	OZA448-E56	0481	1952
Evasion 2.0i	RFU <XU10J2>	2.0	89	06.94-		4	49	1480	OZA448-E56	0481	1952
Evasion 2.0i 16V	RFV <XU10J4R>	2.0	97	05.98-04.00		4	49	1480	OZA448-E56	0481	1952
Evasion 2.0i Turbo	RGX <XU10JETE>	2.0	108	06.94-		4	49	1480	OZA448-E56	0481	1952
Jumper 2.0i	RFW <XU10J2U>	2.0	80	02.94-02.02	Fg.Nr. 15267331 ->	4	49	1480	OZA448-E56	0481	1952
Jumper 2.0i	RFW	2.0	80	02.94-02.02	Fg.Nr. -> 15267330	4	58	1470	OZA527-E3	0201	1919
Jumpy 1.6i	220 A2.000	1.6	58	10.95-		4	49	1480	OZA448-E56	0481	1952
Saxo 1.0i	CDZ	1.0	33	10.98-	Euro 93	3	19	975	OZA446-E2	1855	0412
Saxo 1.0i	CDY <TU9M>	1.0	33	02.96-		4	49	380	OZA448-E57	0492	1952
Saxo 1.0i	CDZ	1.0	33	02.96-		4	49	375	OZA527-E15	0298	1919
Saxo 1.0i	CDY	1.0	37	10.98-	Euro 93	3	19	975	OZA446-E2	1855	0412
Saxo 1.0i	CDZ <TU9M>	1.0	37	02.96-		4	49	380	OZA448-E57	0492	1952
Saxo 1.0i	CDY	1.0	37	02.96-		4	49	375	OZA527-E15	0298	1919
Saxo 1.1i	HDZ	1.1	40	10.98-	Euro 93	3	19	975	OZA446-E2	1855	0412
Saxo 1.1i	HDY <TU1M+>	1.1	40	02.96-	Euro 96	4	49	380	OZA448-E57	0492	1952
Saxo 1.1i	HDY <TU1M+>	1.1	40	02.96-		4	73	370	OZA527-E29	0488	1919
Saxo 1.1i	HDZ	1.1	40	02.96-09.98		4	49	375	OZA527-E15	0298	1919
Saxo 1.1i	HDZ <TU1M+>	1.1	40-44	02.96-		4	73	370	OZA527-E29	0488	1919
Saxo 1.1i	HDZ <TU1M+>	1.1	40-44	02.96-	Euro 96	4	49	380	OZA448-E57	0492	1952
Saxo 1.1i	HDY	1.1	44	02.96-		4	49	375	OZA527-E15	0298	1919
Saxo 1.1i	HDY	1.1	44	10.98-	Euro 93	3	19	975	OZA446-E2	1855	0412
Saxo 1.1	HFZ <TU1JP+>	1.1	44	06.00-	/ Euro 2000	4	82	536	OZA341-PG5	1813	1952
Saxo 1.1	HFZ <TU1JP+>	1.1	44	06.00-	/ Euro 2000	4	82	536	OZA341-PG5	1813	1952
Saxo 1.4i	KFX	1.4	55	10.98-	Euro 96	3	19	975	OZA446-E2	1855	0412
Saxo 1.4i	KFX <TU3JP>	1.4	55	02.96-	Euro 96	4	49	380	OZA448-E57	0492	1952
Saxo 1.4i	KFX	1.4	55	02.96-		4	49	375	OZA527-E15	0298	1919
Saxo 1.4i	KFX <TU3JP>	1.4	55	02.96-		4	73	370	OZA527-E29	0488	1919
Saxo 1.4i	KFX <TU3JP+>	1.4	55	09.99-	/	4	82	536	OZA341-PG5	1813	1952
Saxo 1.4i	KFX <TU3JP+>	1.4	55	09.99-	Euro 2000 Depol L4						
Saxo 1.4i	KFX <TU3JP+>	1.4	55	09.99-	/	4	83	536	OZA495-PG2	1852	1952
Saxo 1.4i	KFX <TU3JP+>	1.4	55	09.99-	Euro 2000 Depol L4						
Saxo 1.6i	NFZ	1.6	66	10.98-	Euro 96	3	19	975	OZA446-E2	1855	0412

Fg = Chassis No.

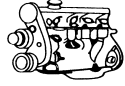

ℓ kW



① ② ③

ORDER NO. STOCK NO. SERIAL NO.

CITROEN

Saxo 1.6i	NFZ <TU5JP>	1.6	66	05.96-01.98	Org. N. -> 7727	4	49	380	OZA448-E57	0492	1952
Saxo 1.6i	NFZ	1.6	65	02.96-		4	49	375	OZA527-E15	0298	1919
Saxo 1.6i	NFX	1.6	87-88	07.96-		4	49	630	OZA527-E16	0434	1919
Saxo 1.6i	NFZ <TU5JP>	1.6	66	02.96-		4	73	370	OZA527-E29	0488	1919
Saxo 1.6i 16V VTS	NFX <TU5J4>	1.6	88	06.97-08.99	/ Euro 96	4	49	536	OZA334-PG1	1790	1952
Saxo 1.6i 16V VTS	NFX <TU5J4>	1.6	88	09.99-01.01	/ Euro 96	4	49	536	OZA334-PG1	1790	1952
Saxo 1.6i 16V VTS	NFX <TU5JP L4>	1.6	88	01.01-	/ Euro 2000	4	82	536	OZA341-PG5	1813	1952
Saxo 1.6i 16V VTS	NFX <TU5JP L4>	1.6	88	01.01-	/ Euro 2000	4	82	536	OZA341-PG5	1813	1952
Saxo 1.6i 16V New Morning	NFX <TU5JP L4>	1.6	88	03.01-12.01	/ Euro 2000	4	82	536	OZA341-PG5	1813	1952
Saxo 1.6i 16V New Morning	NFX <TU5JP L4>	1.6	88	03.01-12.01	/ Euro 2000	4	82	536	OZA341-PG5	1813	1952
Xantia 1.6i	BFZ	1.6	65-66	03.93-05.95	Org. N. ->6779	4	58	450	OZA527-E12	0220	1919
Xantia 1.6i	BFZ	1.6	65-66	06.95-	Org. N. 6780->	4	49	630	OZA527-E16	0434	1919
Xantia 1.8i	L6A	1.8	70-71	03.93-05.95	Org. N. ->6779	4	58	450	OZA527-E12	0220	1919
Xantia 1.8i	L6A	1.8	70-71	06.95-	Org. N. 6780->	4	49	630	OZA527-E16	0434	1919
Xantia 1.8i	LFZ	1.8	74-76	03.93-05-95	Org. N. ->6779	4	58	450	OZA527-E12	0220	1919
Xantia 1.8i	LFZ	1.8	74-76	06.95-	Org. N. 6780->	4	49	630	OZA527-E16	0434	1919
Xantia 1.8i 16V	LFY	1.8	81	05.95-10.96	Org. N. ->7250	4	49	630	OZA527-E16	0434	1919
Xantia 2.0i	RFX	2.0	89-90	03.93-05.95	Org. N. ->6779	4	58	450	OZA527-E12	0220	1919
Xantia 2.0i	RFX	2.0	89-90	06.95-	Org. N. 6780->	4	49	630	OZA527-E16	0434	1919
Xantia 2.0i	R6D	2.0	91-92	03.93-05.95	Org. N. ->6779	4	58	450	OZA527-E12	0220	1919
Xantia 2.0i	R6D	2.0	91-92	06.95-	Org. N. 6780->	4	49	630	OZA527-E16	0434	1919
Xantia 2.0i 16V	RFV <XU10J4R>	2.0	97	06.95-		4	49	1480	OZA448-E56	0481	1952
Xantia 2.0i Turbo	RGX	2.0	108-110	05.95-		4	49	630	OZA527-E16	0434	1919
Xantia 2.0i 16V	RFY	2.0	110-114	03.93-12.96		4	58	1470	OZA527-E3	0201	1919
Xantia 2.0i 16V	RFT	2.0	110-114	03.93-12.96		4	58	1470	OZA527-E3	0201	1919
XM 2.0i	RDZ	2.0	79-81	05.91-06.94	Org. N. 5337->	4	58	1470	OZA527-E3	0201	1919
XM 2.0i	RFZ <XU10J2Z>	2.0	89-90	05.91-06.94	Org. N. 5337->	4	58	1470	OZA527-E3	0201	1919
XM 2.0i	R6A <XU10J2K>	2.0	90-96	05.91-06.94	Org. N. 5337->	4	58	1470	OZA527-E3	0201	1919
XM 2.0i 16V	RFV <XU10J4R>	2.0	97-99	07.94-		4	58	1470	OZA527-E3	0201	1919
XM 2.0i 16V	RFV <XU10J4R>	2.0	99	07.94-10.00		4	49	1480	OZA448-E56	0481	1952
XM 2.0i Turbo	RGY <XU10J2TE/Z>	2.0	104-107	09.92-06.94		4	58	1470	OZA527-E3	0201	1919
XM 2.0i Turbo	RGX <XU10J2TE>	2.0	108	07.94-10.00		4	49	1480	OZA448-E56	0481	1952
Xsara 1.4i	KFX <TU3JP>	1.4	55	07.97-12.97	Org. N. -> 7706	4	49	380	OZA448-E57	0492	1952
Xsara 1.4i Coupe	KFX <TU3JP>	1.4	55	07.97-		4	49	380	OZA448-E57	0492	1952
Xsara 1.4i Coupe	KFX <TU3JP>	1.4	55	03.98-	Org. N. -> 7729	4	73	370	OZA527-E29	0488	1919
Xsara 1.4i Break	KFX <TU3JP>	1.4	55	04.98-		4	73	370	OZA527-E29	0488	1919
Xsara 1.4i	KFX <TU3JP>	1.4	55	07.97-08.00	Org. N. 7706 ->	4	73	370	OZA527-E29	0488	1919
Xsara 1.4i	KFX <TU3JP+>	1.4	55	08.00-	/ Euro 2000	4	82	536	OZA341-PG5	1813	1952
Xsara 1.4i	KFX <TU3JP+>	1.4	55	08.00-	/ Euro 2000	4	83	536	OZA495-PG2	1852	1952
Xsara 1.6i Break	NFZ <TU5JP>	1.6	66	10.97-12.97	Org. N. -> 7706	4	49	380	OZA448-E57	0492	1952
Xsara 1.6i	NFZ <TU5JP>	1.6	66	07.97-12.97	Org. N. -> 7706	4	49	380	OZA448-E57	0492	1952
Xsara 1.6i Break	NFZ <TU5JP>	1.6	66	10.97-08.00	Org. N. 7729 ->	4	73	370	OZA527-E29	0488	1919
Xsara 1.6i	NFZ <TU5JP>	1.6	66	07.97-	Org. N. 7729 ->	4	73	370	OZA527-E29	0488	1919
Xsara 2 1.8i 16V	6FZ <EW7J4>	1.8	85	09.00-	/ Euro 2000 (F)	4	82	1486	OZA341-PG7	1815	1952
Xsara 2 1.8i 16V	6FZ <EW7J4>	1.8	85	09.00-	/ Sensor / Euro 2000	4	83	536	OZA495-PG2	1852	1952
					(F)						
Xsara Picasso 1.8i 16V	6FZ <EW7J4>	1.8	85	12.99-	/ Euro 2000	4	82	1486	OZA341-PG7	1815	1952
Xsara Picasso 1.8i 16V	6FZ <EW7J4>	1.8	85	12.99-	/ Sensor / Euro 2000	4	83	536	OZA495-PG2	1852	1952
ZX 1.1i	HDZ	1.1	44	09.96-	Euro 96	3	19	975	OZA446-E2	1855	0412
ZX 1.1i	HDY	1.1	44	09.96-	Euro 96	3	19	975	OZA446-E2	1855	0412
ZX 1.1i	HDY <TU1M+>	1.1	44	09.96-06.97		4	49	380	OZA448-E57	0492	1952
ZX 1.1i	HDZ <TU1M+>	1.1	44	09.96-06.97		4	49	380	OZA448-E57	0492	1952

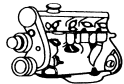

e kW



① ② ③

ORDER
STOCK
 No. No. L.No.
CITROEN

ZX 1.1i	HDY	1.1	44	07.95-08.96	Org. N. 6809->	4	49	1220	OZA527-E17	0445	1919
ZX 1.1i	HDZ	1.1	44	10.91-03.94	Org. N. ->6808	4	58	1470	OZA527-E3	0201	1919
ZX 1.1i	HDY	1.1	44	04.94-06.95	Org. N. ->6808	4	58	1470	OZA527-E3	0201	1919
ZX 1.4i	KFX	1.4	55	06.96-	Euro 96	3	19	975	OZA446-E2	1855	0412
ZX 1.4i	KDX	1.4	55	09.94-06.95		4	58	450	OZA527-E12	0220	1919
ZX 1.4i	KDX	1.4	55	07.95-		4	49	375	OZA527-E15	0298	1919
ZX 1.4i	KDX	1.4	55	07.95-	Org. N. 6809->	4	49	1220	OZA527-E17	0445	1919
ZX 1.4i	KDX	1.4	55	08.92-08.94	Org. N. 5538->6505	4	58	1470	OZA527-E3	0201	1919
ZX 1.4i	KDX	1.4	55	09.94-06.95	Org. N. 6506->6808	4	58	1470	OZA527-E3	0201	1919
ZX 1.4i	KDY, HDY	1.4	55	01.92-08.92	Org. N. 5538->	4	58	1470	OZA527-E3	0201	1919
ZX 1.6i	PRC <TU5JP>	1.6	63	10.96-		4	73	370	OZA527-E29	0488	1919
ZX 1.6i	BFZ	1.6	65	05.95-	Org. N. 6749->	4	49	1220	OZA527-E17	0445	1919
ZX 1.6i	B4A	1.6	65	01.92-	Org. N. 5538->	4	58	1470	OZA527-E3	0201	1919
ZX 1.6i	BFZ	1.6	65	07.93-04.95	Org. N. ->6748	4	58	1470	OZA527-E3	0201	1919
ZX 1.6i	BDY	1.6	65	01.92-	Org. N. 5538->	4	58	1470	OZA527-E3	0201	1919
ZX 1.6i	NFZ <TU5JP>	1.6	66	02.96-10.97		4	73	370	OZA527-E29	0488	1919
ZX 1.8i	LFZ	1.8	74	05.95-	Org. N. 6749->	4	49	1220	OZA527-E17	0445	1919
ZX 1.8i	LFZ	1.8	74	07.92-04.95	Org. N. ->6748	4	58	1470	OZA527-E3	0201	1919
ZX 1.8i	L6A	1.8	74-76	05.95-	Org. N. 6749->	4	49	1220	OZA527-E17	0445	1919
ZX 1.8i	L6A	1.8	74-76	07.93-04.95	Org. N. ->6748	4	58	1470	OZA527-E3	0201	1919
ZX 1.9i	DFY	1.9	88-90	05.95-	Org. N. 6749->	4	49	1220	OZA527-E17	0445	1919
ZX 1.9i	DKZ	1.9	88-90	05.95-	Org. N. 6749->	4	49	1220	OZA527-E17	0445	1919
ZX 1.9i	DFY	1.9	88-90	03.91-04.95	Org. N. ->6748	4	58	1470	OZA527-E3	0201	1919
ZX 1.9i	DKZ	1.9	88-90	03.91-04.95	Org. N. ->6748	4	58	1470	OZA527-E3	0201	1919
ZX 1.9i	D6E	1.9	93-96	03.91-04.95	Org. N. ->6748	4	58	1470	OZA527-E3	0201	1919
ZX 1.9i	D6E	1.9	93-96	05.95-	Org. N. 6749->	4	49	1220	OZA527-E17	0445	1919
ZX 2.0i	RFX	2.0	89	05.95-	Org. N. 6749->	4	49	1220	OZA527-E17	0445	1919
ZX 2.0i	RFX	2.0	89	07.92-04.95	Org. N. ->6748	4	58	1470	OZA527-E3	0201	1919
ZX 2.0i	R6D	2.0	89-90	05.95-	Org. N. 6749->	4	49	1220	OZA527-E17	0445	1919
ZX 2.0i	R6D	2.0	89-90	07.93-04.95	Org. N. ->6748	4	58	1470	OZA527-E3	0201	1919
ZX 2.0i 16V	RFY	2.0	110-114	05.95-	Org. N. 6749->	4	49	1220	OZA527-E17	0445	1919
ZX 2.0i 16V	RFT	2.0	110-114	05.95-	Org. N. 6749->	4	49	1220	OZA527-E17	0445	1919
ZX 2.0i 16V	RFY	2.0	110-114	07.92-04.95	Org. N. ->6748	4	58	1470	OZA527-E3	0201	1919
ZX 2.0i 16V	RFT	2.0	110-114	07.92-04.95	Org. N. ->6748	4	58	1470	OZA527-E3	0201	1919

DAEWOO

Espero 1.5i 16V	A15MF	1.5	66	02.95-06.97		1	6	320	OZA401-E6	1882	1951
Espero 1.8i	C18LE	1.8	66	02.95-06.97		1	6	320	OZA401-E6	1882	1951
Espero 2.0i	C20LE	2.0	77	02.95-06.97		1	6	320	OZA401-E6	1882	1951
Matiz 0.8i	F8CV	0.8	38	09.98-		4	42	310	OZA341-W2	0440	1952
Nexia 1.5	G15MF	1.5	55	02.95-08.97		1	6	320	OZA401-E6	1882	1951
Nexia 1.5i 16V	A15MF	1.5	66	02.95-08.97		1	6	320	OZA401-E6	1882	1951
Royal 2.0i Salon	H20MR	2.0	94	01.88-12.89		3	19	490	OZA446-E11	1898	0412

DAIMLER

Sovereign 3.2	X300	AJ6	3.2	94- 98		4	56	730	OTD3J-5B1	0464	---
Sovereign 4.0	X300	AJ6	4.0	94- 98		4	56	730	OTD3J-5B1	0464	---

FERRARI

348 TB Coupe	F119F000	3.4	217-221	02.90-04.94		4	38	880	OZA527-E4	0218	1919
348 TS Spider	F119F000	3.4	217-221	08.90-04.94		4	38	880	OZA527-E4	0218	1919
512 TR	F113D00 / 40	5.0	315	01.92-10.94		4	38	880	OZA527-E4	0218	1919

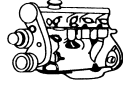

ℓ kW



① ② ③

ORDER
No. No. STOCK
No. No. SERIAL
No. No.**FERRARI**

Mondial 3.2 Quattrovalvole	F105C..	3.2	191	01.86-12.87		3	19	670	OZA446-E1	1833	0412
Testarossa 4.9	F113B..	4.9	272	08.86-10.91		3	19	670	OZA446-E1	1833	0412

FIAT

124 2000i.e. Sport Spider	131AB..	2.0	77	09.81-04.85		1	3	472	OZA401-E2	1802	1951
Barchetta 1.8i 16V	183A1.000	1.8	96	04.95-05.98		4	31	300	OZA112-A2	0225	1952
Barchetta 1.8i 16V	183A1.000	1.8	96	06.98-10.00		4	40	310	OZA334-A3	0245	1952
Barchetta 1.8i 16V	188A6.000	1.8	96	10.00-		4	40	260	OZA532-A3	0409	1952
Barchetta 1.8i 16V	188A6.000	1.8	96	10.00-		4	40	260	OZA532-A3	0409	1952
Brava 1.4 12V	182A5.000	1.4	55	10.95-02.98	4029960->	4	40	378	OZA527-E19	0296	1919
Brava 1.4 12V	182A3.000	1.4	59	10.95-02.98	4029960->	4	40	378	OZA527-E19	0296	1919
Brava 1.6 16V	182A4.000	1.6	74	10.95-04.98		4	31	850	OZA112-A1	0146	1952
Brava 100 16V	182A4.000	1.6	74	12.98-10.00		4	40	610	OZA334-A1	0223	1952
Brava 1.6i 16V	182A4.000	1.6	74	05.98-11.98		4	40	610	OZA334-A1	0223	1952
Brava 1.8 16V	182A2.000	1.8	84	10.95-06.99		4	31	600	OZA112-A3	0157	1952
Brava 1.8 16V- 115 CV	182A2.000	1.8	85	07.99-06.00	Phase 2	4	40	310	OZA341-A1	1798	1952
Bravo 1.4 12V	182A5.000	1.4	55	10.95-02.98		4	40	378	OZA527-E19	0296	1919
Bravo 1.4 12V	182A3.000	1.4	59	10.95-02.98		4	40	378	OZA527-E19	0296	1919
Bravo 1.6 16V	182A4.000	1.6	74	10.95-04.98		4	31	850	OZA112-A1	0146	1952
Bravo 100 16V	182A4.000	1.6	74	12.98-10.00		4	40	610	OZA334-A1	0223	1952
Bravo 1.6i 16V	182A4.000	1.6	74	05.98-11.98		4	40	610	OZA334-A1	0223	1952
Bravo 1.8 16V GT	182A2.000	1.8	84	10.95-06.99		4	31	600	OZA112-A3	0157	1952
Bravo 1.8 16V- 115 CV	182A2.000	1.8	85	07.99-06.00	Phase 2	4	40	310	OZA341-A1	1798	1952
Cinquecento 700i	170 A.000	0.7	23	07.94-02.97		1	2	650	OZA65-A2	1889	1951
Cinquecento 700i	170 A.000	0.7	23	07.94-09.98		1	2	650	OZA65-A2	1889	1951
Cinquecento 900i	170A1.046 /->9147274	0.9	30	10.91-03.95		4	38	880	OZA527-E4	0218	1919
Cinquecento 900i	170A1.046 / 9147275->	0.9	30	03.95-07.98		4	40	972	OZA527-E7	0213	1919
Cinquecento 1100i Sporting	176B2.000	1.1	40	10.94-07.98		4	40	378	OZA527-E19	0296	1919
Coupe 1.8i 16V	183A1.000	1.8	96	02.96-05.98		4	31	600	OZA112-A3	0157	1952
Coupe 1.8i 16V	183A1.000	1.8	96	06.98-12-00		4	40	980	OZA334-A2	0234	1952
Coupe 2.0i 16V	836A3.000/3.011/M1	2.0	104	05.95-09.96		3	22	890	OZA446-E18	1887	0412
Coupe 2.0i 16V	836A3.000/3.011/M1	2.0	104	04.94-05.95		3	19	895	OZA446-E4	1877	0412
Coupe 2.0i 20V	182A1.000/M2	2.0	108	09.96-02.00		4	40	972	OZA527-E7	0213	1919
Coupe 2.0i 20V	182A1.000	2.0	108	10.96-02.00		4	40	972	OZA527-E7	0213	1919
Coupe 2.0i 20V Turbo	175A3.000/M3	2.0	162	09.96-02.00		4	40	972	OZA527-E7	0213	1919
Coupe 2.0i	175A1.000/M2	2.0	143	04.94-09.96		3	19	975	OZA446-E2	1855	0412
Croma 2.0i.e.	834B048	2.0	83-85	03.86-09.90		3	19	670	OZA446-E1	1833	0412
Croma 2.0i.e.	834B146	2.0	85	11.92-12.96		3	19	670	OZA446-E1	1833	0412
Croma 2.0i.e.16V	154E1.000	2.0	101	11.92-12.96		4	38	880	OZA527-E4	0218	1919
Croma 2.0i.e.Turbo	154C4.046	2.0	110	10.90-12.96		3	19	670	OZA446-E1	1833	0412
Croma 2.0i.e.Turbo	834C146	2.0	110-114	07.86-09.90		3	19	670	OZA446-E1	1833	0412
Croma 2.5i.e.	834G.000	2.5	117	06.93-12.96		4	38	1130	OZA527-E5	0253	1919
Doblo 1.6i 16V CNG	223A5.000	1.6	75	11.02-		4	40	410	OZA534-A2	1764	1952
Doblo 1.6i 16V CNG	223A5.000	1.6	75	11.02-		4	40	410	OZA534-A2	1764	1952
Ducato 2.0i.e.	RFW	2.0	80	03.94-		4	49	1480	OZA448-E56	0481	1952
Ducato 2.0i.e. 4x4	RFW	2.0	80	03.94-12.02		4	49	1480	OZA448-E56	0481	1952
Ducato 14 (94)	RFW	2.0	80	03.94-12.02		4	58	1470	OZA527-E3	0201	1919
Ducato 10 (94)	RFW	2.0	80	03.94-12.02		4	58	1470	OZA527-E3	0201	1919
Ducato 18 (94)	RFW	2.0	80	03.94-		4	58	1470	OZA527-E3	0201	1919
Ducato Panorama 2.0	170D	2.0	62	07.90-02.94		3	45	510	OZA446-E48	0280	0412
Ducato Panorama 2.0	170D	2.0	62	09.88-06.90		3	45	510	OZA446-E48	0280	0412
Fiorino 1.4 i.e.	146D5.000	1.4	49	06.95-12.00		4	40	972	OZA527-E7	0213	1919

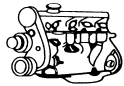

e kW



① ② ③

ORDER
STOCK
 No. No.

FIAT
 No. No.

Fiorino 1.4i.e.	146D5.000	1.4	51	06.95-12.00		4	40	972	OZA527-E7	0213	1919
Fiorino 1.4i.e.	146C5.000	1.4	52	09.93-06.95		3	19	895	OZA446-E4	1877	0412
Fiorino 1.5i.e.	149C1.000	1.5	55	01.88-08.93		3	19	895	OZA446-E4	1877	0412
Fiorino 1.6i.e.	146C6.000	1.6	59	09.93-06.95		3	19	895	OZA446-E4	1877	0412
Fiorino 1.6 i.e.	146D6.000	1.6	59	06.95-12.00		4	40	972	OZA527-E7	0213	1919
Marea 1.4i 12V / Weekend	182A3.000	1.4	59	10.96-02.98	SPI-Bosch	4	40	378	OZA527-E19	0296	1919
Marea 1.6i 16V Weekend	182A4.000	1.6	74	09.96-11.98		4	31	850	OZA112-A1	0146	1952
Marea 1.6i 16V Weekend	182A4.000	1.6	74	09.96-04.98		4	31	850	OZA112-A1	0146	1952
Marea 1.6i 16V Bi -Power	185A3.000	1.6	74	11.97-11.98		4	31	850	OZA112-A1	0146	1952
Marea 1.6i 16V	182A4.000	1.6	74	09.96-04.98		4	31	850	OZA112-A1	0146	1952
Marea 100 16V Bi - Power	185A3.000	1.6	74	12.98-10.00		4	40	610	OZA334-A1	0223	1952
Marea 1.6i 16V Weekend	182A4.000	1.6	74	05.98-11.98		4	40	610	OZA334-A1	0223	1952
Marea 100 16V Weekend	182A4.000	1.6	74	12.98-06.00		4	40	610	OZA334-A1	0223	1952
Marea 1.6i 16V	182A4.000	1.6	74	05.98-11.98		4	40	610	OZA334-A1	0223	1952
Marea 100 16V	182A4.000	1.6	74	12.98-06.00		4	40	610	OZA334-A1	0223	1952
Marea 1.6i 16V	182A4.000	1.6	75	11.00-		4	40	980	OZA532-A1	0478	1952
Marea 1.6i 16V	182B6.000	1.6	75	11.00-12.02		4	40	610	OZA534-A1	1762	1952
Marea 1.8i 16V Weekend	182A2.000	1.8	84	09.96-06.99		4	31	600	OZA112-A3	0157	1952
Marea 1.8i 16V	182A2.000	1.8	84	09.96-06.99		4	31	600	OZA112-A3	0157	1952
Marea 1.8 16V	182A4.000	1.8	85	07.99-10.00	Phase 2	4	40	310	OZA341-A1	1798	1952
Marea 2.0i 20V	182A1.000	2.0	108	10.96-06.99	①	4	40	972	OZA527-E7	0213	1919
Marea 2.0i 20V / Weekend	182A1.000	2.0	108	10.96-02.99	①	4	40	972	OZA527-E7	0213	1919
Multipla 1.6i 16V	182A4.000	1.6	75	01.99-09.00		4	40	980	OZA334-A2	0234	1952
Multipla 1.6i 16V Blu-Power	182A3.000	1.6	75	01.99-09.00		4	40	980	OZA334-A2	0234	1952
Multipla 1.6i 16V Bi-Power	182A4.000	1.6	75	01.99-12.00		4	40	980	OZA334-A2	0234	1952
Multipla 1.6i 16V	182B6.000	1.6	75	10.00-		4	40	980	OZA532-A1	0478	1952
Multipla 1.6i 16V	182B6.000	1.6	75	10.00-		4	40	610	OZA534-A1	1762	1952
Multipla 1.6i 16V Bi-Power	182B6.000	1.6	75	10.00-		4	40	980	OZA532-A1	0478	1952
Multipla 1.6i 16V Bi-Power	182B6.000	1.6	75	10.00-		4	40	610	OZA534-A1	1762	1952
Multipla 1.6i 16V Blu-Power	182B6.000	1.6	75	10.00-		4	40	980	OZA532-A1	0478	1952
Multipla 1.6i 16V Blu-Power	182B6.000	1.6	75	10.00-		4	40	610	OZA534-A1	1762	1952
Multipla 1.6i 16V ELX	182B6.000	1.6	75	10.00-		4	40	980	OZA532-A1	0478	1952
Multipla 1.6i 16V ELX	182B6.000	1.6	75	10.00-		4	40	610	OZA534-A1	1762	1952
Multipla 1.6i 16V SX	182B6.000	1.6	75	10.00-		4	40	980	OZA532-A1	0478	1952
Multipla 1.6i 16V SX	182B6.000	1.6	75	10.00-		4	40	610	OZA534-A1	1762	1952
Nuova Panda 1.1i	187A1.000	1.1	40	09.03-		4	40	310	OZA532-A10	1794	---
Nuova Panda 1.1i	187A1.000	1.1	40	09.03-		4	40	310	OZA532-A10	1794	---
Nuova Panda 1.2i 8V	188A4.000	1.2	44	09.03-		4	40	310	OZA532-A10	1794	---
Nuova Panda 1.2i 8V	188A4.000	1.2	44	09.03-		4	40	310	OZA532-A10	1794	---
Palio 1.2 Weekend / Strada	178B5.000	1.2	54	10.97-11.00	1 sensor only (F2) (P) (TR)	4	40	400	OZA112-A6	1759	1952
Palio 1.4i (Siena)	178B2.000	1.4	59	10.97-09.01	Phase 2 ① (P) (TR)	4	40	700	OZA112-A7	1760	1952
Palio 1.6i 16V Weekend	178B3.000	1.6	74	11.97-10.99		4	40	800	OZA112-A4	0236	1952
Palio 1.6i 16V Weekend	178B3.000	1.6	74	09.99-09.00		4	40	980	OZA334-A2	0234	1952
Palio 1.6 RST	182B6.000	1.6	75	10.00-		4	40	810	OZA532-A9	1793	1952
Palio 1.6 RST	182B6.000	1.6	75	10.00-		4	40	410	OZA534-A2	1764	1952
Panda 900i.e.	1170A1.046	0.9	29	1991-03.92	base gamma 94, iniezione Weber ①	4	38	880	OZA527-E4	0218	1919
Panda 900i.e.	1170A1.046	0.9	29	02.95-12.00	No 1146723 SPI USA 84 ①	4	40	972	OZA527-E7	0213	1919
Panda 1000i.e. 4x4	156A2.146	1.0	33	10.87-05.91		3	19	670	OZA446-E1	1833	0412
Panda 1000i.e.	156A2.146	1.0	33	10.87-05.91		3	19	670	OZA446-E1	1833	0412
Panda 1000i.e.	156A2.246	1.0	33	01.86-04.92	①	3	19	975	OZA446-E2	1855	0412

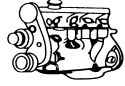

ℓ kW



① ② ③

ORDER
No. No.
STOCK
No. No.
SERIES
A. L. No.**FIAT**

Panda 1000i.e. 4x4	156A2.246	1.0	33	01.86-06.90	①	3	19	975	OZA446-E2	1855	0412
Panda 1000i.e.	141C2.000	1.0	33	01.95-11.00		4	40	972	OZA527-E7	0213	1919
Panda 1100i.e. Selecta	156C.046	1.1	37	07.90-12.92	①	3	19	975	OZA446-E2	1855	0412
Panda 1100i.e. 4x4	156C.046	1.1	37	03.92-12.92	①	3	19	975	OZA446-E2	1855	0412
Panda 1100i.e.	156C.046	1.1	37	03.92-12.92		3	19	895	OZA446-E4	1877	0412
Panda 1100i.e Selecta	176B2.000	1.1	37	01.95-11.00	①	4	40	972	OZA527-E7	0213	1919
Panda 1100i.e Selecta	176B2.000	1.1	40	01.95-11.00	SPI-Weber	4	40	972	OZA527-E7	0213	1919
Panda 1100 i.e.	176B2.000	1.1	40	01.95-11.00		4	40	972	OZA527-E7	0213	1919
Panda 1100i.e	176B2.000	1.1	40	01.95-11.00	SPI-Weber	4	40	972	OZA527-E7	0213	1919
Panda 1.1i 8V	187A1.001	1.1	40	10.00-06.04		4	40	260	OZA532-A3	0409	1952
Panda 1.1i 8V	187A1.001	1.1	40	10.00-06.04		4	40	260	OZA532-A3	0409	1952
Punto 1.1i.e. 55	176A6.000	1.1	40	08.93-12.94	SPI-Weber	4	38	880	OZA527-E4	0218	1919
Punto 1.1i.e. 55	176B2.000	1.1	40	01.95-09.99	SPI-Weber	4	40	972	OZA527-E7	0213	1919
Punto 1.2i.e. 60	176A7.000	1.2	43	08.93-05.94	SPI-Weber	4	38	880	OZA527-E4	0218	1919
Punto 1.2i.e. 60 Cabrio	176A7.000	1.2	43	08.93-05.94	SPI-Weber	4	38	880	OZA527-E4	0218	1919
Punto 1.2i.e. 60 Selecta	176B1.000	1.2	43	01.95-05.95	SPI-Weber	4	40	972	OZA527-E7	0213	1919
Punto 1.2i.e. 60	176B4.000	1.2	43	01.95-09.99	SPI-Weber	4	40	972	OZA527-E7	0213	1919
Punto 1.2i.e. 60 Cabrio	176B4.000	1.2	43	06.95-09.99	SPI-Weber	4	40	972	OZA527-E7	0213	1919
Punto 1.2i.e. 75	176A8.000	1.2	54	01.95-09.99	MPI-Weber	4	40	972	OZA527-E7	0213	1919
Punto 1.2i.e. 75	176A8.000	1.2	54	08.93-12.94	MPI-Weber	4	38	880	OZA527-E4	0218	1919
Punto 1.4i.e. GT Turbo	176A4.000/176B6.000	1.4	98	08.93-12.94		4	38	880	OZA527-E4	0218	1919
Punto 1.4i.e. GT Turbo	176A4.000/176B6.000	1.4	98	01.95-09.99		4	40	972	OZA527-E7	0213	1919
Punto GT 1.4 i.e. Turbo	176A4.000/176B6.000	1.4	98	08.93-08.99	Mot.Nr. 9240633 ->	4	40	972	OZA527-E7	0213	1919
Punto 1.6 90 / Sporting	176A9.000	1.6	65	08.93-05.97		4	42	820	OZA448-E13	1893	1952
Punto 1.8i 16V HGT	183A1.000	1.8	96	09.99-10.00		4	40	610	OZA334-A1	0223	1952
Punto 1.8i 16V HGT	188A6.000	1.8	96	09.00-		4	40	260	OZA532-A3	0409	1952
Punto 1.8i 16V HGT	188A6.000	1.8	96	09.00-		4	40	1370	OZA532-A4	1786	1952
Punto 1.8i 16V HGT	188A6.000	1.8	96	09.00-		4	40	980	OZA532-A7	1796	1952
Regata 75i.e.	138C2..	1.5	55	10.85-04.87		1	3	472	OZA401-E2	1802	1951
Regata 75i.e.	149C1.000	1.5	55	05.87-06.90		3	19	895	OZA446-E4	1877	0412
Ritmo 75i.e.	138C2..	1.5	55	10.85-10.87		1	3	472	OZA401-E2	1802	1951
Ritmo 75i.e.	149C1..	1.5	55	05.87-12.88		3	19	895	OZA446-E4	1877	0412
Ritmo 90i.e.	149C2.000	1.6	66	05.87-12.87		3	19	895	OZA446-E4	1877	0412
Scudo 1.6i	220 A2.000	1.6	58	10.95-05.00		4	49	1480	OZA448-E56	0481	1952
Seicento 1100i	176 B2.000	1.1	40	03.98-06.00		4	40	378	OZA527-E19	0296	1919
Seicento 1.1i 8V	187A1.000	1.1	40	10.00-		4	40	260	OZA532-A3	0409	1952
Seicento 1.1i 8V	187A1.000	1.1	40	10.00-		4	40	260	OZA532-A3	0409	1952
Stilo 1.8i 16V	192A4.000	1.8	96	10.01-		4	40	610	OZA532-A2	0489	1952
Stilo 1.8i 16V	192A4.000	1.8	96	10.01-	2↑	4	40	260	OZA532-A3	0409	1952
Tempra 1.4i.e.	160A1.046	1.4	51	03.92-03.95	SPI-Bosch	3	19	895	OZA446-E4	1877	0412
Tempra 1.4i.e. SW	160A1.046	1.4	51	03.92-03.95	SPI-Bosch	3	19	895	OZA446-E4	1877	0412
Tempra 1.4 i.e.	836A4.000	1.4	51	03.95-12.96		4	40	972	OZA527-E7	0213	1919
Tempra 1.4i.e.	836A4.000	1.4	51	03.95-12.96	SPI-Bosch	4	40	972	OZA527-E7	0213	1919
Tempra 1.4i.e. SW	836A4.000	1.4	51	03.95-12.96	SPI-Bosch	4	40	972	OZA527-E7	0213	1919
Tempra 1.6i.e. SW	159A3.046	1.6	52	01.91-07.92	SPI-Bosch	3	19	895	OZA446-E4	1877	0412
Tempra 1.6i.e. SW	835C1.000	1.6	55	04.93-12.96	SPI-Bosch	4	40	972	OZA527-E7	0213	1919
Tempra 1.6i.e.	835C1.000	1.6	55	04.93-12.96	SPI-Bosch	4	40	972	OZA527-E7	0213	1919
Tempra 1.6 i.e.	835C1.000	1.6	55	01.95-12.96		4	40	972	OZA527-E7	0213	1919
Tempra 1.6i.e. Selecta	159A3.046	1.6	57	06.90-07.92	SPI-Bosch	3	19	895	OZA446-E4	1877	0412
Tempra 1.6i.e.	159A3.046	1.6	59	06.90-07.92	SPI-Bosch	3	19	895	OZA446-E4	1877	0412
Tempra 1.6i.e.	159B9.000	1.6	66	04.94-10.96		4	42	820	OZA448-E13	1893	1952
Tempra 1.8i.e.	835C4.000	1.8	66	04.93-12.96	MPI-Weber	4	38	880	OZA527-E4	0218	1919

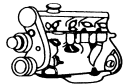

e kW



① ② ③

ORDER
STOCK
 No. No.

FIAT

Tempra 1.8i.e.	159A4.046	1.8	76	04.93-12.96	MPI-Weber	4	38	880	OZA527-E4	0218	1919
Tempra 1.8i.e.	159A4.046	1.8	76	04.93-12.96	MPI-Weber	4	38	880	OZA527-E4	0218	1919
Tempra 1.8i.e.	159A5.046	1.8	77	03.92-03.93	MPI-Weber	3	19	670	OZA446-E1	1833	0412
Tempra 1.8i.e.	159A5.046	1.8	77	03.92-03.93	MPI-Weber	3	19	670	OZA446-E1	1833	0412
Tempra 1.8i.e.	159A4.000	1.8	80	02.90-09.92	MPI-Weber	3	19	670	OZA446-E1	1833	0412
Tempra 1.8i.e.	159A4.000	1.8	80	12.90-09.92	MPI-Weber	3	19	670	OZA446-E1	1833	0412
Tempra 2.0i.e. SW 4x4	159A6.046	2.0	83	03.92-12.96	MPI-Weber	3	19	670	OZA446-E1	1833	0412
Tempra 2.0i.e.	159AC6.046	2.0	85	02.90-12.96	MPI-Weber	3	19	670	OZA446-E1	1833	0412
Tipo 1.4i.e.	160A1.046	1.4	51	05.89-03.93	SPI-Bosch	3	19	895	OZA446-E4	1877	0412
Tipo 1.4i.e.	160A1.046	1.4	52	03.93-10.95		3	19	895	OZA446-E4	1877	0412
Tipo 1.6i.e. Selectra	159A3.048	1.6	56	03.93-10.95		3	19	895	OZA446-E4	1877	0412
Tipo 1.6i.e.	835C1.000	1.6	56	03.93-10.95		4	38	880	OZA527-E4	0218	1919
Tipo 1.6i.e.	159A3.046	1.6	57	01.92-03.93	SPI-Bosch	3	19	895	OZA446-E4	1877	0412
Tipo 1.6i.e.	159A3.046	1.6	57	03.90-03.93	SPI-Bosch	3	19	895	OZA446-E4	1877	0412
Tipo 1.8i.e.	835C2.000	1.8	77	03.93-10.95		3	19	895	OZA446-E4	1877	0412
Tipo 1.8i.e. GT	159A4.046	1.8	77	03.92-03.93	MPI-Weber	3	19	895	OZA446-E4	1877	0412
Tipo 2.0i.e.	159A6.046	2.0	83	03.90-03.92	MPI-Weber	3	19	895	OZA446-E4	1877	0412
Tipo 2.0i.e.	159A6.046	2.0	85	03.93-10.95		3	19	895	OZA446-E4	1877	0412
Tipo 2.0i.e.	159A6.046	2.0	85	03.93-10.95		3	19	895	OZA446-E4	1877	0412
Tipo 2.0i.e. 16V	836A3.000	2.0	104	03.93-10.95		3	19	895	OZA446-E4	1877	0412
Ulysse 1.8i	LFW	1.8	75	05.96-05.00		4	49	1480	OZA448-E56	0481	1952
Ulysse 2.0i.e.	RFU	2.0	90	09.94-05.00		4	49	1480	OZA448-E56	0481	1952
Ulysse 2.0i.e. Turbo	RGX	2.0	110	09.94-05.00		4	49	1480	OZA448-E56	0481	1952
Uno 45i.e. Fire	156A2..	1.0	33	10.87-08.89	SPI-Bosch	1	3	472	OZA401-E2	1802	1951
Uno 45i.e. Van	156A2.246	1.0	33	09.92-03.94		3	19	670	OZA446-E1	1833	0412
Uno 45i.e.	156A2.246	1.0	33	06.92-03.94		3	19	895	OZA446-E4	1877	0412
Uno 1.0i.e.	146C7.000	1.0	35	07.94-06.97		4	31	290	OZA114-A1	1856	1952
Uno 1.1i.e.	146C3.000	1.1	36	09.89-03.94		3	19	975	OZA446-E2	1855	0412
Uno 1.1i.e.	156C.046	1.1	37	06.92-03.94		3	19	895	OZA446-E4	1877	0412
Uno 1.3i.e. Turbo	146A2..	1.3	73	10.87-08.89		3	19	895	OZA446-E4	1877	0412
Uno 1.3i.e. Turbo	146A2.146	1.3	74	09.89-03.91		3	19	895	OZA446-E4	1877	0412
Uno Uno 70 i.e.	146C1.000	1.4	52	09.89-09.92		3	19	885	OZA445-E6	0258	0412
Uno 70i.e.	160A1.046	1.4	51	09.89-03.94		3	19	895	OZA446-E4	1877	0412
Uno 75i.e.	138C2..Kat.	1.5	55	10.85-08.87		1	3	472	OZA401-E2	1802	1951
Uno 75i.e.	149C1.000	1.5	55	09.87-08.89	SPI-Bosch	3	19	895	OZA446-E4	1877	0412
Uno 75i.e. Selecta	149C1.000	1.5	55	05.92-03.94		3	19	895	OZA446-E4	1877	0412
Uno 75i.e.	149C1.000	1.5	55	09.89-03.94		3	19	895	OZA446-E4	1877	0412

FORD

Cougar 2.0i 16V	ED-Zetec-E SEFI	2.0	96	10.98-		4	32	372	OZA519-D1	0244	1952
Cougar 2.5i V6	LCBA-Duratec-VE SEFI	2.5	125	10.98-		4	32	372	OZA519-D1	0244	1952
Cougar 2.5i V6	LCBB-Duratec-VE SEFI	2.5	125	10.98-		4	32	372	OZA519-D1	0244	1952
Cougar 2.5i V6	LCBC-Duratec-VE SEFI	2.5	125	10.98-		4	32	372	OZA519-D1	0244	1952
Cougar 2.5i V6	LCBE-Duratec-VE SEFI	2.5	125	10.98-		4	32	372	OZA519-D1	0244	1952
Cougar 2.5i V6 ST200	MABB-Duratec-VE SEFI	2.5	151	01.00-		4	32	372	OZA519-D1	0244	1952
Escort 1.3i	J6A	1.3	44	05.91-12.91		4	27	270	OZA448-E12	1865	1952
Escort 1.3i (95)	J6A	1.3	44	01.95-		4	27	375	OZA448-E44	0293	1952
Escort 1.3i	J6A	1.3	44	10.92-12.94		4	27	375	OZA448-E44	0293	1952
Escort 1.4i	F6F, F6G	1.4	52	05.91-12.91		4	27	270	OZA448-E12	1865	1952
Escort 1.4i	F6F, F6G	1.4	52	10.92-12.94		4	27	375	OZA448-E44	0293	1952

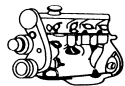

e kW



① ② ③

ORDER
STOCK
 No. No. L.No.
FORD

Escort 1.4i (95)	F4B	1.4	52-55	01.95-		4	27	375	OZA448-E44	0293	1952
Escort 1.4i	F6B , F6D	1.4	54	01.87-07.90		3	25	271	OZA446-E46	0139	0412
Escort 1.4i	F6B , F6D	1.4	54	09.89-07.90		4	27	270	OZA448-E12	1865	1952
Escort 1.4i Cabrio	F6B, F6D	1.4	54	01.87-07.90	OE	4	63	270	OZA448-E39	0210	1952
Escort 1.4i	F6B, F6D	1.4	54	01.87-07.90	OE	4	63	270	OZA448-E39	0210	1952
Escort 1.4i Turnier	F6B, F6D	1.4	54	01.87-07.90	OE	4	63	270	OZA448-E39	0210	1952
Escort 1.4i Express 55 (95)	F4B	1.4	54	01.95-		4	27	375	OZA448-E44	0293	1952
Escort 1.4i Express 75 (95)	F4B	1.4	54	01.95-		4	27	375	OZA448-E44	0293	1952
Escort 1.4i Turnier	F4B	1.4	54-55	02.94-12.94		4	27	375	OZA448-E44	0293	1952
Escort 1.6i 16V (95)	L1H	1.6	65	01.95-		4	27	610	OZA448-E48	0239	1952
Escort 1.6	L1E	1.6	66	09.96-		4	27	600	OZA33-D8	1867	1952
Escort 1.6	L1K	1.6	66	09.96-		4	27	600	OZA33-D8	1867	1952
Escort 1.6	L1E	1.6	66	09.92-09.95		4	27	600	OZA33-D8	1867	1952
Escort 1.6	LIK,LIE - Zetec	1.6	66	08.95-07.00		4	27	360	OZA89-D2	0135	1952
Escort 1.6i	L4B	1.6	66	01.86-07.90		3	25	271	OZA446-E46	0139	0412
Escort 1.6i 16V	L1E	1.6	66	01.93-12.94		4	27	610	OZA448-E48	0239	1952
Escort 1.6i 16V (95)	L1K	1.6	66	01.95-		4	27	610	OZA448-E48	0239	1952
Escort 1.6i 16V 4x4 (95)	L1E	1.6	66	01.95-		4	27	610	OZA448-E48	0239	1952
Escort 1.6i XR3i	L4B	1.6	66	01.86-07.90		3	25	271	OZA446-E46	0139	0412
Escort 1.6i XR3i	LJB	1.6	75	08.89-07.90		3	25	271	OZA446-E46	0139	0412
Escort 1.6i XR3i	LJB	1.6	75	09.89-07.90		4	27	270	OZA448-E12	1865	1952
Escort 1.6i	LJF	1.6	77-79	05.91-12.91		4	27	270	OZA448-E12	1865	1952
Escort 1.6i Cabrio	LJE	1.6	77-79	05.91-12.91		4	27	270	OZA448-E12	1865	1952
Escort 1.6i XR3i	LJA	1.6	79	09.89-07.90		4	27	270	OZA448-E12	1865	1952
Escort 1.8	RDA	1.8	77	10.96-		4	27	600	OZA33-D8	1867	1952
Escort 1.8	RDA - Zetec SEFI	1.8	77	01.92-09.95		4	27	600	OZA33-D8	1867	1952
Escort 1.8i 16V (95)	RDA	1.8	77	01.95-		4	27	610	OZA448-E48	0239	1952
Escort 1.8i 16V XR3i	RDA	1.8	77	01.93-12.94		4	27	610	OZA448-E48	0239	1952
Escort 1.8	RKA - Zetec	1.8	85	08.95-01.99		4	27	360	OZA89-D2	0135	1952
Escort 1.8i 16V (95)	RKC	1.8	85	01.95-		4	27	610	OZA448-E48	0239	1952
Escort 1.8	RQB	1.8	96	10.96-		4	27	600	OZA33-D8	1867	1952
Escort 1.8	RQB	1.8	96	04.93-03.96		4	27	600	OZA33-D8	1867	1952
Escort 1.8i 16V XR 3i Cabrio (95)	RQB	1.8	96	01.95-		4	27	610	OZA448-E48	0239	1952
Escort 1.8i 16V XR3i	RQB	1.8	96	01.93-12.94		4	27	610	OZA448-E48	0239	1952
Escort 2.0i RS	N7A	2.0	110	09.91-12.94		4	27	610	OZA448-E48	0239	1952
Escort 2.0i 16V RS 2000 (95)	N7A	2.0	110	01.95-		4	27	610	OZA448-E48	0239	1952
Escort RS 2000	N7A	2.0	110	05.91-12.92		4	27	720	OZA448-E55	0470	1952
Escort RS 2000 4x4	N7A	2.0	110	08.93-01.95		4	27	720	OZA448-E55	0470	1952
Fiesta 1.1i	G6A	1.1	36-37	03.89-12.92		4	27	270	OZA448-E12	1865	1952
Fiesta 1.1i	G6A	1.1	36-37	01.93-12.96		4	27	375	OZA448-E44	0293	1952
Fiesta 1.25i 16V	DH - Zetec SEFI	1.25	55	08.98-12.99		4	32	372	OZA519-D1	0244	1952
Fiesta 1.3i (96)	JJA, JJC	1.3	37	10.95-		4	27	375	OZA448-E44	0293	1952
Fiesta 1.3i	J6B	1.3	43-44	06.91-12.92		4	27	270	OZA448-E12	1865	1952
Fiesta 1.3i	J6B	1.3	43-44	01.93-12.96		4	27	375	OZA448-E44	0293	1952
Fiesta 1.3i (96)	J4C, J4J	1.3	44	10.95-		4	27	375	OZA448-E44	0293	1952
Fiesta 1.4i	F6A , F6C	1.4	52	10.86-02.89		3	25	271	OZA446-E46	0139	0412
Fiesta 1.4i	F6E	1.4	52	03.89-12.92		4	27	270	OZA448-E12	1865	1952
Fiesta 1.4i	F6E	1.4	52	01.93-12.96		4	27	375	OZA448-E44	0293	1952
Fiesta 1.6	LUH - Zetec SEFI	1.6	66	02.94-09.95		4	27	600	OZA33-D8	1867	1952
Fiesta 1.6i 16V	L1 - Zetec SEFI	1.6	76	02.00-		4	32	372	OZA519-D1	0244	1952
Fiesta 1.6i XR2i	LJD	1.6	76	03.89-12.92		4	27	270	OZA448-E12	1865	1952
Fiesta 1.6 XR2i	LJC, LJD	1.6	76-81	01.93-12.96		4	27	375	OZA448-E44	0293	1952

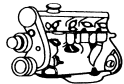

e kW



① ② ③

ORDER
STOCK
 No. No.
 L No.
FORD

Fiesta 1.6i XR2i	LJC	1.6	81	03.89-12.92		4	27	270	OZA448-E12	1865	1952
Fiesta 1.8	RDP - Zetec	1.8	77	01.93-01.94		4	27	300	OZA33-D5	0199	1952
Fiesta 1.8	RQC - Zetec	1.8	96	01.93-10.95		4	27	300	OZA33-D5	0199	1952
Focus 1.4i 16V	FX - Zetec-SE SFI	1.4	55	07.00-		4	32	372	OZA519-D1	0244	1952
Focus 1.4i 16V	Zetec-SE	1.4	55	08.00-		4	32	372	OZA381-D1	1820	1952
Focus 1.6i 16V	FY - Zetec-SE SFI	1.6	74	07.00-		4	32	372	OZA519-D1	0244	1952
Focus 1.6i 16V	Zetec	1.6	74	07.00-		4	32	372	OZA381-D1	1820	1952
Focus 1.8i 16V	EY - Zetec-E SFI	1.8	85	10.98-		4	32	372	OZA519-D1	0244	1952
Focus 1.8i 16V	Zetec-E	1.8	85	07.00-		4	32	372	OZA381-D1	1820	1952
Focus 2.0i 16V	ED - Zetec-E SFI	2.0	96	10.99-		4	32	372	OZA519-D1	0244	1952
Focus 2.0i 16V	Zetec-E	2.0	96	07.00-		4	32	372	OZA381-D1	1820	1952
Focus 2.0i 16V ST170	Duratec ST	2.0	127	03.02-		4	32	393	OZA488-D2	1757	1952
Galaxy 2.8i V6	AAA	2.8	128	01.96-10.97		4	48	720	OZA447-E31	0460	1952
Galaxy 2.8i V6 4x4	AAA	2.8	128	04.96-04.00		4	48	720	OZA447-E31	0460	1952
Galaxy 2.8i V6	AAA	2.8	128	11.95-12.95		4	48	1430	OZA447-E36	1950	1952
Ka 1.3i	JJB	1.3	37	09.96-01.99		4	27	375	OZA448-E44	0293	1952
Ka 1.3i	J4K	1.3	44	09.96-07.98		4	27	375	OZA448-E44	0293	1952
Ka 1.3i	J4D	1.3	44	09.96-07.98		4	27	375	OZA448-E44	0293	1952
Ka 1.3i	J4 - Endura	1.3	44	08.98-		4	32	372	OZA519-D1	0244	1952
Ka 1.6i	Rocam	1.6	70	07.03-		4	32	372	OZA488-SZ1	1766	- - -
Mondeo 1.6i	L1J - Zetec	1.6	65	09.96-		4	27	360	OZA216-D2	0190	1952
Mondeo 1.6i 16V	L1J DOHC	1.6	65	02.93-07.96		4	27	375	OZA448-E44	0293	1952
Mondeo 1.6i	L1F - Zetec-E SEFI	1.6	66	08.96-07.98		4	27	360	OZA216-D2	0190	1952
Mondeo 1.6i	L1F - Zetec-E SEFI	1.6	66	02.93-07.96		4	27	300	OZA89-D1	1890	1952
Mondeo 1.6i 16V	L1F DOHC	1.6	66	02.93-07.96		4	27	375	OZA448-E44	0293	1952
Mondeo 1.8i 16V	Zetec	1.8	85	08.98-10.00		4	32	372	OZA381-D1	1820	1952
Mondeo 1.8i	RKB - Zetec	1.8	82	08.96-		4	27	360	OZA216-D2	0190	1952
Mondeo 1.8i 16V	RKB DOHC	1.8	82	02.93-07.96		4	27	375	OZA448-E44	0293	1952
Mondeo 1.8i	RKA - Zetec-E SEFI	1.8	85	08.96-07.98		4	27	360	OZA216-D2	0190	1952
Mondeo 1.8i	RKA - Zetec-E SEFI	1.8	85	02.93-07.96		4	27	300	OZA89-D1	1890	1952
Mondeo 1.8i 16V	RKA DOHC	1.8	85	02.93-07.96		4	27	375	OZA448-E44	0293	1952
Mondeo 2.0i	NGA - Zetec-E SEFI	2.0	96	08.96-07.98		4	27	710	OZA216-D3	0125	1952
Mondeo 2.0i 16V	Zetec	2.0	96	08.98-10.00		4	32	372	OZA381-D1	1820	1952
Mondeo 2.0i	Zetec-E SEFI	2.0	100	08.96-07.98		4	27	710	OZA216-D3	0125	1952
Mondeo 2.0i	NGA - Zetec-E SEFI	2.0	100	02.93-07.96		4	27	300	OZA89-D1	1890	1952
Mondeo 2.0i 16V	NGA DOHC	2.0	100	02.93-07.96		4	27	375	OZA448-E44	0293	1952
Mondeo 2.0i 16V 4x4	NGA DOHC	2.0	100	07.93-07.96		4	27	375	OZA448-E44	0293	1952
Mondeo 2.5i	SEA V6	2.5	125	08.96-		4	27	360	OZA216-D2	0190	1952
Mondeo 2.5i	SEA V6	2.5	125	10.94-07.96		4	27	360	OZA89-D2	0135	1952
Mondeo II 1.6i 16V	L1J - Zetec-E SEFI	1.6	66	08.98-		4	32	372	OZA519-D1	0244	1952
Mondeo II 1.6i 16V Turnier	L1J - Zetec-E SEFI	1.6	66	08.98-		4	32	372	OZA519-D1	0244	1952
Mondeo II 1.8i 16V	RK - Zetec-E SEFI	1.8	82	10.00-		4	32	372	OZA519-D1	0244	1952
Mondeo II 1.8i 16V Turnier	RK - Zetec-E SEFI	1.8	82	10.00-		4	32	372	OZA519-D1	0244	1952
Mondeo II 2.0i 16V	NGA - Zetec-E SEFI	2.0	96	10.00-		4	32	372	OZA519-D1	0244	1952
Mondeo II 2.0i 16V Turnier	NGA - Zetec-E SEFI	2.0	96	10.00-		4	32	372	OZA519-D1	0244	1952
Mondeo II 2.5i	V6 SEFI	2.5	125	06.99-11.00		4	32	372	OZA381-D1	1820	1952
Mondeo II 2.5i	V6 SEFI	2.5	125	98- 00		4	32	393	OZA488-D2	1757	1952
Orion 1.3i	J6A	1.3	44	05.91-12.91		4	27	270	OZA448-E12	1865	1952
Orion 1.4i	F6F, F6G	1.4	52	05.91-12.91		4	27	270	OZA448-E12	1865	1952
Orion 1.4i	F6B, F6D	1.4	54	10.87-07.90		3	25	271	OZA446-E46	0139	0412
Orion 1.6i	L4B	1.6	66	09.85-07.90		3	25	271	OZA446-E46	0139	0412
Orion 1.6i	L1E	1.6	66	09.92-08.93		4	27	600	OZA33-D8	1867	1952

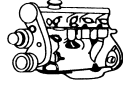

ℓ kW



① ② ③

ORDER
No. No.
STOCK
No. No.
SINCE
1988
L.No.**FORD**

Orion 1.6i	LJF	1.6	77	05.91-12.91		4	27	270	OZA448-E12	1865	1952
Orion 1.6i	LJE	1.6	79	05.91-12.91		4	27	270	OZA448-E12	1865	1952
Orion 1.8i	RDA	1.8	77	01.92-08.93		4	27	600	OZA33-D8	1867	1952
Orion 1.8i	RQB	1.8	96	02.92-08.93		4	27	600	OZA33-D8	1867	1952
Probe 2.5i 24V		2.5	121	07.91-06.97		4	31	480	OZA74-F1	0401	1952
Puma 1.6i 16V		1.6	76	10.00-		4	32	372	OZA519-D1	0244	1952
Scorpio 2.0	NER, NE4	2.0	74	10.87-08.89		4	63	270	OZA448-E39	0210	1952
Scorpio 2.0	NRC	2.0	74	10.85-12.90	OE	4	63	270	OZA448-E39	0210	1952
Scorpio 2.0i	NRC	2.0	74	10.85-05.89		3	25	271	OZA446-E46	0139	0412
Scorpio 2.0	NEL	2.0	77	04.85-08.89		4	63	270	OZA448-E39	0210	1952
Scorpio 2.0	N8B, N8D	2.0	77-82	05.89-02.92		4	63	270	OZA448-E39	0210	1952
Scorpio 2.0	NRA EFI HC	2.0	85	04.85-02.92		4	63	270	OZA448-E39	0210	1952
Scorpio 2.0i	N9F	2.0	85	02.92-09.94		4	27	720	OZA448-E55	0470	1952
Scorpio 2.0i Turnier	N9F	2.0	85	09.91-09.94		4	27	720	OZA448-E55	0470	1952
Scorpio 2.0	N9D	2.0	88	05.89-08.89		4	63	270	OZA448-E39	0210	1952
Scorpio 2.0i	N9D	2.0	88	09.89-02.92		4	27	270	OZA448-E12	1865	1952
Scorpio 2.0	N9B	2.0	93	05.89-08.89		4	63	270	OZA448-E39	0210	1952
Scorpio 2.0i	N9B	2.0	93	09.89-02.92		4	27	270	OZA448-E12	1865	1952
Scorpio 2.4i	ARD	2.4	92	10.88-04.89	Y	3	25	271	OZA446-E46	0139	0412
Scorpio 2.4i (92)	ARD	2.4	92	02.92-12.94		4	27	555	OZA448-E42	0271	1952
Scorpio 2.4i (92)	ARD	2.4	92	10.92-12.94	Y	4	27	375	OZA448-E44	0293	1952
Scorpio 2.9i (92)	BRF	2.9	107	02.92-12.94	Y	4	27	555	OZA448-E42	0271	1952
Scorpio 2.9i (92)	BRF	2.9	107	10.92-12.94	Y	4	27	375	OZA448-E44	0293	1952
Scorpio 2.9i 4x4 (92)	BRE	2.9	107	02.92-12.94	Y	4	27	555	OZA448-E42	0271	1952
Scorpio 2.9i 4x4 (92)	BRE	2.9	107	10.92-12.94	Y	4	27	375	OZA448-E44	0293	1952
Scorpio 2.9i (95)	BRG	2.9	110	01.95-12.98		4	27	555	OZA448-E42	0271	1952
Scorpio 2.9i (95) Turnier	BRG	2.9	110	01.95-12.98		4	27	555	OZA448-E42	0271	1952
Scorpio 2.9i 24V (92)	BOA	2.9	143	02.92-12.94	Y	4	27	555	OZA448-E42	0271	1952
Scorpio 2.9i 24V (92)	BOA	2.9	143	10.92-12.94	Y	4	27	375	OZA448-E44	0293	1952
Scorpio 2.9i 24V (95)	BOB	2.9	152	01.95-12.98		4	27	375	OZA448-E44	0293	1952
Sierra 1.6i	L6B	1.6	59	01.90-02.93		4	27	270	OZA448-E12	1865	1952
Sierra 1.6i	L6B	1.6	59	10.89-01.90		4	63	270	OZA448-E39	0210	1952
Sierra 1.6i Turnier	L6B	1.6	59	10.89-01.90		4	63	270	OZA448-E39	0210	1952
Sierra 1.8	CVH	1.8	63-66	01.87-12.92		4	27	600	OZA33-D8	1867	1952
Sierra 2.0i	N4B	2.0	74	01.87-11.91		3	25	271	OZA446-E46	0139	0412
Sierra 2.0i	NRD	2.0	74	10.85-12.86		3	25	271	OZA446-E46	0139	0412
Sierra 2.0i	N4B	2.0	74	11.91-02.93		4	27	270	OZA448-E12	1865	1952
Sierra 2.0i Turnier	N4B	2.0	74	01.87-02.93		4	63	270	OZA448-E39	0210	1952
Sierra 2.0i	NR2	2.0	85	10.85-12.86		3	25	271	OZA446-E46	0139	0412
Sierra 2.0i	N4A	2.0	85	01.87-11.91		3	25	271	OZA446-E46	0139	0412
Sierra 2.0i	N4I	2.0	85	01.87-10.89		3	25	271	OZA446-E46	0139	0412
Sierra 2.0i	N4A	2.0	85	11.91-02.93		4	27	270	OZA448-E12	1865	1952
Sierra 2.0 4x4	N9C	2.0	88	01.90-02.93		4	27	720	OZA448-E55	0470	1952
Sierra 2.0 4x4 Turnier	N9C	2.0	88	02.90-02.93		4	27	720	OZA448-E55	0470	1952
Sierra 2.0 XR4i	N9C	2.0	88	01.90-02.93		4	63	720	OZA527-E28	0477	1919
Sierra 2.0i	N9C	2.0	88	06.89-02.93		4	27	600	OZA33-D8	1867	1952
Sierra 2.0i HB	N9C	2.0	88	06.89-02.93		4	63	720	OZA527-E28	0477	1919
Sierra 2.0i Turnier	N9C	2.0	88	05.89-02.93		4	63	720	OZA527-E28	0477	1919
Sierra 2.9i 4x4 XR4i	B4A	2.9	110	08.88-11.89	Y	3	25	271	OZA446-E46	0139	0412
Sport Ka 1.6i	Rocam	1.6	70	07.03-		4	32	372	OZA488-SZ1	1766	1952
Street Ka 1.6i	Rocam	1.6	70	05.03-		4	32	372	OZA488-SZ1	1766	1952
Transit 2.0i	N6T	2.0	57	10.88-09.91		3	25	271	OZA446-E46	0139	0412

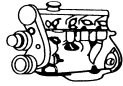

e kW



① ② ③

ORDER
STOCK
 No. No. L.No.
FORD

Transit 2.0i SWB 80-150	NCA	2.0	72	04.93-10.94		4	27	570	OZA448-E41	0260	1952
Transit 2.0i LWB 100-190	NCA	2.0	72	04.93-10.94		4	27	570	OZA448-E41	0260	1952

HONDA

Accord IV 2.0i 16V Coupe	CCI	F20A7	2.0	98	01.92-09.93		4	17	583	OZA446-E42	0150	1952
Accord IV 2.2i 16V Aerodeck	CB8	F22A8	2.2	108	01.91-12.93		4	17	583	OZA446-E42	0150	1952
Accord IV 2.2i 16V Aerodeck	CB8	F22A7	2.2	110	01.91-12.93		4	17	583	OZA446-E42	0150	1952
Accord V 2.0i	CC7	F20Z2	2.0	85	03.93-09.95		4	17	583	OZA446-E42	0150	1952
Accord V 2.0i S	CC7	F20Z1	2.0	96	03.93-09.95		4	17	583	OZA446-E42	0150	1952
Accord VI 1.8i 16V	CE7	F18A3	1.8	85	09.94-		4	44	450	OZA501-H23	0469	1952
Accord VI 1.8i 16V	CE7	F18A3	1.8	85	09.94-		4	43	240	OZA569-H1	0499	1952
Accord VI 1.9i	CE7	F18A	1.9	85	02.96-10.98		4	44	410	OZA245-H1	0169	1952
Accord VI 2.0i	CE8	F20Z / F20B	2.0	96	02.96-10.98		4	44	410	OZA245-H1	0169	1952
Accord VI 2.0i	CE8	F20B / F20Z	2.0	100	02.96-10.98		4	44	410	OZA245-H1	0169	1952
Accord VI 2.0i 16V	CE2	F20B3	2.0	100	09.94-		4	44	450	OZA501-H23	0469	1952
Accord VI 2.0i 16V	CE2	F20B3	2.0	100	09.94-		4	43	240	OZA569-H1	0499	1952
Accord VI 2.2i	CE9	F22Z	2.2	110	02.96-10.98		4	43	225	OZA245-H2	0180	1952
Accord VI 2.2i 16V	CD7	F22B5	2.2	110	09.94-		4	44	450	OZA501-H23	0469	1952
Accord VI 2.2i 16V	CD7	F22B5	2.2	110	09.94-		4	43	240	OZA569-H1	0499	1952
Accord VII 1.8i	CG	F18B	1.8	100	10.98-		4	44	450	OZA333-H19	0277	1952
Accord VII 1.8i	CG	F18B	1.8	100	10.98-		4	43	240	OZA421-H1	0255	1952
Accord VII 1.8i	CG	F18B	1.8	100	10.98-		4	43	240	OZA501-H17	0266	1952
Accord VII 2.2i Type-R	CG	F22Z	2.2	156	02.99-		4	44	450	OZA333-H19	0277	1952
Accord VII 2.2i Type-R	CG	F22Z	2.2	156	02.99-		4	43	240	OZA421-H1	0255	1952
Accord VII 3.0 V6 24V Coupe	CG	J30A1	3.0	147	02.98-		3	14	1220	OZA446-E3	1866	0412
Civic II 1.5i		EW4	1.5	66	84- 87		1	7	470	OZA401-E52	0164	1951
Civic II 1.6i 16V Shuttle 4WD	EE4	D16A6	1.6	80	01.88-12.89		1	5	370	OZA401-E57	0153	1951
Civic II 1.6i 16V Shuttle 4WD	EE4	D16A6	1.6	81	01.88-02.95		1	5	370	OZA401-E57	0153	1951
Civic III 1.3i 16V HB	EC8	D13B2	1.3	55	09.89-09.91		1	5	370	OZA401-E57	0153	1951
Civic III 1.5i 16V HB	ED8	D15B2	1.5	69	10.88-09.91		1	5	370	OZA401-E57	0153	1951
Civic III 1.5i 16V Sedan	ED3	D15B2	1.5	69	12.89-09.91		1	5	370	OZA401-E57	0153	1951
Civic III 1.6i 16V HB	ED7	D16A6	1.6	80	10.87-09.91		1	5	370	OZA401-E57	0153	1951
Civic III 1.6i 16V Sedan	ED4	D16A6	1.6	80	10.89-09.91		1	5	370	OZA401-E57	0153	1951
Civic III 1.6i 16V HB	ED7	D16Z2	1.6	81	10.87-09.91		1	5	370	OZA401-E57	0153	1951
Civic III 1.6i 16V Sedan	ED4	D16Z2	1.6	81	10.87-09.91		1	5	370	OZA401-E57	0153	1951
Civic IV 1.5i Vtec-E	MA9	D15Z3	1.5	66	09.94-01.97		3	19	1665	OZA446-E49	0291	0412
Civic IV 1.6i 16V Sedan	MB1	D16Z7	1.6	88	10.91-09.95		4	43	410	OZA502-E28	0425	1952
Civic IV 1.6i 16V Sedan	MB1	D16Z6	1.6	92	10.91-09.95		4	43	410	OZA502-E28	0425	1952
Civic IV 1.6i HB	EH9	D16Z6	1.6	92	10.91-09.95		4	43	410	OZA502-E28	0425	1952
Civic V 1.4i 16V	MB8	D14A	1.4	66	02.99-		4	43	245	OZA333-H25	0288	1952
Civic V 1.4i 16V	MB8	D14A	1.4	66	02.99-		4	43	320	OZA333-H26	0299	1952
Civic V 1.5i 16V	EJ9	D14A	1.4	55-66	97-		4	43	320	OZA333-H4	0137	1952
Civic V 1.5i 16V	MB9	D15Z	1.5	84	02.99-		4	43	410	OZA333-H27	0212	1952
Civic V 1.5i	EK3	D15Z	1.5	84	97-		4	43	410	OZA333-H5	0148	1952
Civic V 1.6i	EK1	D16Y	1.6	84	02.99-		4	43	245	OZA333-H25	0288	1952
Civic V 1.6i	EK1	D16Y	1.6	84	02.99-		4	43	320	OZA333-H26	0299	1952
Civic V 1.6i		D16Y	1.6	84	97-		4	43	320	OZA333-H4	0137	1952
Civic V 1.8i	MB6	B18C4	1.8	124	97-		4	43	235	OZA333-H6	0159	1952
Civic V 1.8i 16V	MC2	B18C	1.8	124	02.99-		4	43	240	OZA501-H17	0266	1952
Concerto 1.5i 16V	HW	D15B2	1.5	66	08.89-12.92		1	5	370	OZA401-E57	0153	1951
Concerto 1.6i 16V	HW	D16Z2	1.6	82	08.89-12.92		1	5	370	OZA401-E57	0153	1951
CRX 1.6i 16V	ED9	D16Z5	1.6	91	10.87-02.92		1	5	370	OZA401-E57	0153	1951

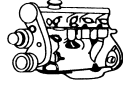

ℓ kW



① ② ③

ORDER
No. No. STOCK
No. No. SIZES
L No.**HONDA**

CRX III 1.6i 16V	EH6	D16Z6	1.6	92	03.92-12.98		4	43	410	OZA502-E28	0425	1952
CRX III 1.6i ESi	EH6	D16Y8	1.6	92	03.92-12.98		4	43	410	OZA502-E28	0425	1952
Prelude 1.8i EX	AB	ET4	1.8	74	11.85-04.87		1	5	380	OZA401-E56	0154	1951
Prelude 2.0i EX	BA4	B20A3	2.0	80	04.87-01.92		1	5	370	OZA401-E57	0153	1951

HYUNDAI

Accent 1.3i		G4EH	1.3	44	07.94-07.99		3	79	265	OZA446-E56	0461	0412
Accent 1.3i		G4EH	1.3	55	07.94-07.99		3	79	265	OZA446-E56	0461	0412
Accent 1.3i		G4EH	1.3	62	07.94-07.99		3	79	265	OZA446-E56	0461	0412
Accent 1.5i		G4EK	1.5	63-68	07.94-07.99		3	79	265	OZA446-E56	0461	0412
Accent 1.5i		G4EK	1.5	70-71	04.94-07.99		3	79	265	OZA446-E56	0461	0412
Elantra 1.5i		New Orion	1.5	63	10.90-04.95		1	8	550	OZA25-KH3	1969	1951
Excel 1.3 Ecotronic		New Orion	1.3	43	04.89-07.94		1	8	550	OZA25-KH3	1969	1951
Excel 1.3i		G4EH	1.3	55	07.94-07.99		3	79	265	OZA446-E56	0461	0412
Excel 1.5i Ecotronic		New Orion	1.5	53	04.89-07.94		1	8	550	OZA25-KH3	1969	1951
Excel 1.5i		New Orion	1.5	61	04.89-07.94		1	8	550	OZA25-KH3	1969	1951
H 100 2.4i		New Sirius	2.4	90	07.93-		1	8	550	OZA25-KH3	1969	1951
Lantra 1.5i		New Orion	1.5	63	10.90-04.95		1	8	550	OZA25-KH3	1969	1951
Pony 1.3		New Orion	1.3	45-49	04.89-07.94		1	8	550	OZA25-KH3	1969	1951
Pony 1.3i		G4EH	1.3	62	07.94-07.99		3	79	265	OZA446-E56	0461	0412
Pony 1.5i Ecotronic		New Orion	1.5	53	04.89-07.94		1	8	550	OZA25-KH3	1969	1951
Pony 1.5i		New Orion	1.5	61	04.89-07.94		1	8	550	OZA25-KH3	1969	1951
S-Coupe 1.5i		G4EK	1.5	65	08.92-12.94		3	79	265	OZA446-E56	0461	0412
S-Coupe 1.5i		Alpha G4EK	1.5	65-68	07.92-06.93		3	19	975	OZA446-E2	1855	0412
S-Coupe 1.5i		4G62	1.5	70	06.88-06.93		1	8	550	OZA25-KH3	1969	1951
S-Coupe 1.5i GT Turbo		Alpha G4EK-TC	1.5	84-85	04.91-06.93		3	19	975	OZA446-E2	1855	0412
Sonata 1.8i		4G62	1.8	70	06.88-06.93		1	8	650	OZA25-KH1	1940	1951
Sonata 2.0i		4G63	2.0	72-74	06.88-06.93		1	8	650	OZA25-KH1	1940	1951
Sonata 2.4i		4G64	2.4	80-82	01.89-10.93		1	8	650	OZA25-KH1	1940	1951

INNOCENTI

Elba 1.4i.e.		146C5.000	1.4	49	09.93-06.95		3	19	895	OZA446-E4	1877	0412
Elba 1.4i.e.		146D5.000	1.4	49	06.95-06.97		4	38	880	OZA527-E4	0218	1919
Elba 1.6i.e.		146C6.000 Jetronic	1.6	55	09.93-03.96		3	19	895	OZA446-E4	1877	0412
Elba 1.6i.e.		146C6.000 Motronic	1.6	55	03.96-06.97		4	38	880	OZA527-E4	0218	1919
Mille 1.0i 8V		146C7.000	1.0	35	09.95-06.97		4	31	290	OZA114-A1	1856	1952

JAGUAR

Daimler 3.6i		AJ6.4 DOHC	3.6	136	10.86-08.89		3	19	975	OZA446-E2	1855	0412
Sovereign 2.9i		AJ6	2.9	104	10.86-08.90		3	19	975	OZA446-E2	1855	0412
Sovereign 3.2i 24V		AJ6 OHC	3.2	149	09.90-		3	19	975	OZA446-E2	1855	0412
Sovereign 3.6i		AJ6 DOHC	3.6	135	10.86-08.89	Ⓧ	3	19	975	OZA446-E2	1855	0412
Sovereign 6.0 XJ 81		OHC	6.0	234	03.93-		3	19	975	OZA446-E2	1855	0412
S-Type 3.0i		AJ-V6	3.0	175	10.98-09.00		4	32	271	OZA381-D2	0451	1952
S-Type 3.0i		AJ-V6	3.0	175	09.94-		4	32	393	OZA381-D3	0462	1952
S-Type 3.0i		AJ-V6	3.0	175	09.94-		4	32	271	OZA488-D1	0403	1952
S-Type 4.0i		AJ-V8	4.0	205	09.94-		4	32	393	OZA381-D3	0462	1952
S-Type 4.0i		AJ-V8	4.0	205	09.94-		4	32	271	OZA488-D1	0403	1952
XJ 6 2.9i		AJ6	2.9	108-117	10.86-12.88		3	19	975	OZA446-E2	1855	0412
XJ 6 3.2i 24V		AJ6 OHC	3.2	146	10.90-09.94		3	19	975	OZA446-E2	1855	0412
XJ 6 3.2i		AJ6	3.2		10.94-		4	56	730	OTD3J-5B1	0464	---
XJ 6 3.2i		AJ6	3.2		10.94-		4	56	730	OTD3J-5B1	0464	---

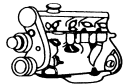

ℓ kW



① ② ③

ORDER
STOCK
 No. No. L.No.
JAGUAR

XJ 6 3.6i	AJ6.4 DOHC	3.6	136	10.86-08.89		3	19	975	OZA446-E2	1855	0412
XJ 6 4.0i	AJ6 DOHC	4.0	163	09.89-09.94		3	19	895	OZA446-E4	1877	0412
XJ 6 4.0i	AJ6	4.0		10.94-		4	56	730	OTD3J-5B1	0464	- - -
XJ 6 4.2i		4.2	147	03.79-10.86		3	19	975	OZA446-E2	1855	0412
XJ S 3.6i	AJ3.6 DOHC	3.6	165	10.86-12.88		3	19	975	OZA446-E2	1855	0412
XJ S 3.6i SC Cabriolet	AJ3.6 DOHC	3.6	165	10.86-12.88		3	19	975	OZA446-E2	1855	0412
XJ S 4.0i	AJ6 DOHC	4.0	163-166	05.91-09.94		3	19	975	OZA446-E2	1855	0412
XJ S 4.0i	AJ6	4.0		94-		4	56	730	OTD3J-5B1	0464	- - -
XJ S 5.3i	HE V12	5.3	183	07.81-12.87		3	19	975	OZA446-E2	1855	0412
XJ S 6.0i V12	DOHC	6.0	222-227	05.92-		3	19	975	OZA446-E2	1855	0412
XJ12 5.3i	V12HE	5.3	194	07.81-09.94		3	19	975	OZA446-E2	1855	0412

LANCIA

Dedra 1.6i	835C1.000	1.6	55	04.93-10.94	SPI-Bosch ①	4	38	880	OZA527-E4	0218	1919
Dedra 1.6i	835A1.046	1.6	57	08.89-03.93	①	3	19	895	OZA446-E4	1877	0412
Dedra 1.6i.e 16V	182A4.000	1.6	74	01.98-01.00		4	40	610	OZA334-A1	0223	1952
Dedra 1.6i.e 16V S.W.	182A4.000	1.6	74	01.98-01.00		4	40	610	OZA334-A1	0223	1952
Dedra 1.8i	836A5.000	1.8	74	10.94-12.95	MPI-Weber	4	40	972	OZA527-E7	0213	1919
Dedra 1.8i	836A5.000	1.8	74	10.94-12.95	MPI-Weber	4	40	972	OZA527-E7	0213	1919
Dedra 1.8i SW	836A5.000	1.8	74	10.94-12.95	MPI-Weber	4	40	972	OZA527-E7	0213	1919
Dedra 1.8i SW	836A5.000	1.8	74	10.94-12.95	MPI-Weber	4	40	972	OZA527-E7	0213	1919
Dedra 1.8i	835A2046	1.8	77	09.89-10.94	MPI-Weber	3	19	895	OZA446-E4	1877	0412
Dedra 1.8i 16V	182A2.000	1.8	83	01.96-01.00	MPI-Hit.	4	40	972	OZA527-E7	0213	1919
Dedra 1.8i 16V SW	182A2.000	1.8	83	01.96-01.00	MPI-Hit.	4	40	972	OZA527-E7	0213	1919
Dedra 1.8i 16V	182A2.000	1.8	84	06.96-12.97		4	31	600	OZA112-A3	0157	1952
Dedra 1.8i 16V S.W.	182A2.000	1.8	84	06.96-12.97		4	31	600	OZA112-A3	0157	1952
Dedra 1.8i 16V	182A1.000	1.8	96	06.96-12.97		4	31	600	OZA112-A3	0157	1952
Dedra 1.8i 16V S.W.	182A1.000	1.8	96	06.96-12.97		4	31	600	OZA112-A3	0157	1952
Dedra 1.8i.e 16V	182A2.000	1.8	96	01.98-09.99		4	40	980	OZA334-A2	0234	1952
Dedra 1.8i.e 16V S.W.	182A2.000	1.8	96	01.98-09.99		4	40	980	OZA334-A2	0234	1952
Dedra 2.0i	835A5.046	2.0	83	01.89-09.94	MPI-Weber	3	19	895	OZA446-E4	1877	0412
Dedra 2.0i 16V	836A3.000	2.0	102	10.94-08.96	MPI-Weber	3	22	890	OZA446-E18	1887	0412
Dedra 2.0i 16V 4x4 SW	836A3.000	2.0	102	10.94-08.96	MPI-Weber	3	22	890	OZA446-E18	1887	0412
Dedra 2.0i 16V SW	836A3.000	2.0	102	10.94-08.96	MPI-Weber	3	22	890	OZA446-E18	1887	0412
Dedra 2.0i Turbo	835A8.046	2.0	119	11.90-10.94	MPI-Weber	3	19	670	OZA446-E1	1833	0412
Dedra 2.0i Turbo	835A8.046	2.0	119	11.90-10.94	MPI-Weber	3	19	670	OZA446-E1	1833	0412
Dedra 2.0i Turbo 4x4	835A7.046	2.0	124	04.91-10.94	MPI-Weber	3	19	670	OZA446-E1	1833	0412
Dedra 2.0i Turbo 4x4	835A7.046	2.0	124	04.91-10.94	MPI-Weber	3	19	670	OZA446-E1	1833	0412
Delta 1.4i.e.	160A1.046	1.4	51	01.93-04.94	SPI-Bosch	3	19	895	OZA446-E4	1877	0412
Delta 1.4i.e.	160A1.046	1.4	51	05.94-01.00	SPI-Bosch	4	38	880	OZA527-E4	0218	1919
Delta 1.4 i.e.	836A4.000	1.4	51	04.94-01.00		4	40	972	OZA527-E7	0213	1919
Delta 1.5i.e.	138C..	1.5	55	12.85-10.87		1	3	472	OZA401-E2	1802	1951
Delta 1.6 i.e.	835C1.000	1.6	55	01.93-03.98		4	40	972	OZA527-E7	0213	1919
Delta 1.6i.e.	835C1.000	1.6	55	01.93-12.95	SPI-Bosch	4	38	880	OZA527-E4	0218	1919
Delta 1.6 16V	182A4.000	1.6	74	06.96-03.98		4	31	850	OZA112-A1	0146	1952
Delta 1.6i.e 16V HPE	182A4.000	1.6	74	04.98-01.00		4	40	610	OZA334-A1	0223	1952
Delta 1.8i.e.	835C4.000	1.8	66	01.93-01.00	MPI-Weber	4	40	972	OZA527-E7	0213	1919
Delta 1.8i.e.	835C5.000	1.8	71	01.93-12.94	MPI-Weber	4	38	880	OZA527-E4	0218	1919
Delta 1.8i.e.	836A5.000/A6.000	1.8	71	01.93-12.94		4	40	972	OZA527-E7	0213	1919
Delta 1.8 i.e.	836A5.000/836A6.000	1.8	74	01.95-05.98		4	40	972	OZA527-E7	0213	1919
Delta 1.8i.e.	835C2.000	1.8	76	01.93-12.94	MPI-Weber	4	38	880	OZA527-E4	0218	1919
Delta 1.8 16V	182A2.000	1.8	84	06.96-05.98		4	31	600	OZA112-A3	0157	1952

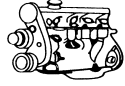

ℓ kW



① ② ③

ORDER
STOCK
 No. No. L.No.
LANCIA

Delta 1.8 16V	182A1.000	1.8	96	06.96-05.98		4	31	600	OZA112-A3	0157	1952
Delta 1.8i.e 16V HPE	182A2.000	1.8	96	06.98-01.00		4	40	980	OZA334-A2	0234	1952
Delta 2.0i.e. 16V	836A3.000	2.0	102	01.95-12.95	MPI-Weber	3	22	890	OZA446-E18	1887	0412
Delta 2.0i.e. 16V	836A3.000	2.0	102	01.93-12.94	MPI-Weber	3	19	895	OZA446-E4	1877	0412
Delta 2.0i.e. 16V Turbo HPE	836A2.000	2.0	137	01.93-09.96	MPI-Weber	3	19	975	OZA446-E2	1855	0412
Delta 2.0i.e. 16V Turbo HPE	175A4.000	2.0	137	09.96-	MPI-Weber	3	19	975	OZA446-E2	1855	0412
Kappa 2.0i 20V	838A1.000	2.0	110	11.94-06.98	▶	4	40	972	OZA527-E7	0213	1919
Kappa 2.0i 20V	838A1.000	2.0	110	11.94-06.96	▶	4	40	972	OZA527-E7	0213	1919
Kappa 2.0i 20V	838A6.000	2.0	114	06.96-06.98	▶	4	40	972	OZA527-E7	0213	1919
Kappa 2.0i 20V S.W.	838A6.000	2.0	114	06.96-06.98	▶	4	40	972	OZA527-E7	0213	1919
Kappa 2.0i 16V Turbo Coupe	838A4.000	2.0	151	01.97-12.01	▶	4	40	971	OZA527-E7	0213	1919
Kappa 2.0i 16V Turbo S.W.	838A4.000	2.0	151	11.94-06.98	▶	4	40	972	OZA527-E7	0213	1919
Kappa 2.4i 20V	838A2.000	2.4	129	11.94-06.98	▶	4	40	972	OZA527-E7	0213	1919
Kappa 2.4i 20V S.W.	838A2.000	2.4	129	11.94-06.98	▶	4	40	972	OZA527-E7	0213	1919
Kappa 2.4i 20V Coupe	838A2.000	2.4	129	01.97-06.98	▶	4	40	972	OZA527-E7	0213	1919
Kappa 3.0 V6 24V S.W.	838B.000	3.0	150	11.94-04.99	▶	3	22	890	OZA446-E18	1887	0412
Kappa 3.0 V6 24V Coupe	838B.000	3.0	150	01.97-04.99	▶	3	22	890	OZA446-E18	1887	0412
Kappa 3.0 V6 24V Coupe	838B.000	3.0	150	05.99-12.01		4	40	1175	OZA527-E24	0287	1919
Kappa 3.0 V6 24V S.W.	838B.000	3.0	150	05.99-12.01		4	40	1175	OZA527-E24	0287	1919
Kappa 3.0 V6 24V	838B.000	3.0	150	11.94-04.99		4	40	1175	OZA527-E24	0287	1919
Lybra 1.6i 16V	182A4.000	1.6	74	09.99-09.00		4	40	610	OZA334-A1	0223	1952
Lybra 1.6i 16V S.W.	182A4.000	1.6	74	09.99-09.00		4	40	610	OZA334-A1	0223	1952
Lybra 1.6i 16V	182B6.000	1.6	75	10.00-		4	40	410	OZA534-A2	1764	1952
Lybra 1.6i 16V	182B6.000	1.6	75	10.00-	🚗	4	40	980	OZA534-A3	1800	1952
Lybra 1.8i 16V	182A2.000	1.8	96	09.99-09.00		4	40	980	OZA334-A2	0234	1952
Lybra 1.8i 16V S.W.	182A2.000	1.8	96	09.99-09.00		4	40	980	OZA334-A2	0234	1952
Lybra 1.8i 16V	839A7.000	1.8	96	10.00-	🔧	4	40	610	OZA532-A2	0489	1952
Lybra 1.8i 16V	839A7.000	1.8	96	10.00-	🔧	4	40	260	OZA532-A3	0409	1952
Lybra 1.8i 16V	839A7.000	1.8	96	10.00-	Rear-EU3	4	40	1810	OZA532-A5	1792	1952
Prisma 1.5i.e.	138C..	1.5	55	12.85-12.86	▶	1	3	472	OZA401-E2	1802	1951
Prisma 1.6i.e.	831B..	1.6	66	05.87-12.89	SPI-Weber	1	3	472	OZA401-E2	1802	1951
Thema 2.0i.e.	834B0..	2.0	83-85	03.86-09.88		3	19	670	OZA446-E1	1833	0412
Thema 2.0i.e.	834B146	2.0	84	05.92-11.94		3	19	670	OZA446-E1	1833	0412
Thema 2.0i.e. 16V	834B2.000	2.0	107	02.89-05.92		3	19	895	OZA446-E4	1877	0412
Thema 2.0i.e. Turbo	834C146	2.0	110	07.86-05.90		3	19	670	OZA446-E1	1833	0412
Thema 2.0i.e. 16V	834F1.000	2.0	112	05.92-11.94		4	38	880	OZA527-E4	0218	1919
Thema 2.0i.e. Turbo 16V	834C1.246	2.0	132	04.89-05.92		3	19	895	OZA446-E4	1877	0412
Thema 2.9i V6	PRV834E146	2.9	108	06.88-09.91		3	19	1215	OZA446-E16	1859	0412
Thema 8.32	Ferrari F105L..	2.9	150	12.87-12.90		3	19	1215	OZA446-E16	1859	0412
Thema 3.0i.e.	834F.000	3.0	126	05.92-11.94		4	38	1130	OZA527-E5	0253	1919
Y 1.2 i.e.	840A3.000	1.2	44	01.96-10.96	SPI-Weber	4	40	972	OZA527-E7	0213	1919
Y 1.2 i.e.	840A3.000	1.2	44	10.96-06.00		4	40	885	OZA448-E37	0152	1952
Y 1.4i.e. 12V	840A4.000	1.4	55	01.96-12.98	1370 SPI 12V "LX" ①	4	40	972	OZA527-E7	0213	1919
					Depontenziato (75CV)						
Y 1.4i.e. 12V	840A2.000	1.4	55-59	01.96-12.98		4	40	972	OZA527-E7	0213	1919
Y 10 1.0i.e Fire 4WD	156A2.146	1.0	33	10.87-07.89		3	19	670	OZA446-E1	1833	0412
Y 10 1.0i.e.Fire	156A2.146	1.0	33	10.87-07.89		3	19	670	OZA446-E1	1833	0412
Y 10 1.0i.e.Fire	156A2.256	1.0	33	01.89-12.90		3	19	895	OZA446-E4	1877	0412
Y 10 1.0i.e.Fire	156A2.256	1.0	33	01.89-02.92		3	19	895	OZA446-E4	1877	0412
Y 10 1.1i.e.Fire	156C046	1.1	37	07.89-09.92		3	19	895	OZA446-E4	1877	0412
Y 10 1.1 i.e. Selectronic	156C046	1.1	37	09.92-12.95		4	38	880	OZA527-E4	0218	1919
Y 10 1.1i.e.	156C046	1.1	37	09.92-12.95		4	38	880	OZA527-E4	0218	1919



e kW



① ② ③

ORDER
STOCK
 No. No. L.No.
LANCIA

Y 10 1.1i.e. 4WD	156C046	1.1	37	09.92-12.95		4	38	880	OZA527-E4	0218	1919
Y 10 1.3 i.e.	146A5.046	1.3	53	09.92-12.95		3	19	895	OZA446-E4	1877	0412
Y 10 1.3i.e.Fire	146A5.046	1.3	53	02.89-09.92		3	19	895	OZA446-E4	1877	0412
Y 10 1.3i.e.Fire	146A5.046	1.3	54	11.87-06.89		3	19	610	OZA446-E44	0162	0412
Zeta 2.0i.e. Turbo	RGX	2.0	110	09.94-06.99		4	49	1480	OZA448-E56	0481	1952
Zeta 2.0i.e.Turbo	RGX	2.0	110	09.94-		4	58	1470	OZA527-E3	0201	1919

LAND ROVER

Defender 3.5i	V8 EFI	3.5	107-115	09.88-12.98		3	55	521	OTD3G-3A1	0453	---
Discovery 3.5i	V8 EFI	3.5	107-113	09.88-12.98		3	55	521	OTD3G-3A1	0453	---
Discovery 3.9i	V8 EFI	3.9	136	10.93-12.98		3	55	521	OTD3G-3A1	0453	---
Range Rover I 3.5i	V8 EFI	3.5	110	01.88-08.90		3	55	521	OTD3G-3A1	0453	---
Range Rover I 3.9i	37D	3.9	127	01.89-01.95		3	55	521	OTD3G-3A1	0453	---
Range Rover I 3.9i	38D	3.9	127	01.89-01.95		3	55	521	OTD3G-3A1	0453	---
Range Rover I 4.3i	40D	4.3	149	09.92-07.94		3	55	521	OTD3G-3A1	0453	---
Range Rover II 4.0i	42D	4.0	136-140	09.94-09.95		3	55	521	OTD3G-3A1	0453	---
Range Rover II 4.0i	42D	4.0	136-140	10.95-09.02		4	43	521	OTD3J-5C1	0475	---
Range Rover II 4.6i	46D	4.6	160-166	10.95-09.02		4	43	521	OTD3J-5C1	0475	---
Range Rover III 4.4i	BMW	4.4	210	03.02-		4	68	290	OZA447-E27	0416	1952
Range Rover III 4.4i	BMW	4.4	210	03.02-		4	69	975	OZA447-E29	0438	1952

MAZDA

121 II 1.3i 16V	DB	D3	1.3	53	01.91-03.96		3	15	350	OZA73-F1	0177	0412
323 IV 1.3i HB	BG	B3E	1.3	49	09.89-07.94		1	9	450	OZA401-E55	0143	1951
323 IV 1.3i Sedan	BG	B3	1.3	49	09.89-06.91		1	9	450	OZA401-E55	0143	1951
323 IV 1.3i 16V HB	BG	B3	1.3	54	08.91-07.94		1	9	450	OZA401-E55	0143	1951
323 IV 1.3i 16V Sedan	BG	B3	1.3	54	04.91-07.94		1	9	450	OZA401-E55	0143	1951
323 IV 1.6i	BG	B6E	1.6	62	09.89-06.91		1	9	450	OZA401-E55	0143	1951
323 IV 1.6i Sedan	BG	B6E	1.6	62	09.89-06.91		1	9	450	OZA401-E55	0143	1951
323 IV 1.6i 16V Sedan	BG	B6	1.6	65	03.91-10.94		1	9	450	OZA401-E55	0143	1951
323 IV 1.6i 16V	BG	B6	1.6	65	03.91-10.94		1	9	450	OZA401-E55	0143	1951
323 IV 1.9i 16V	BG	B5	1.9	94	09.89-03.93		1	9	450	OZA401-E55	0143	1951
323 V 1.5i	BA	Z5	1.5	65	07.94-09.98	Fg.Nr.-> 194444	3	16	380	OZA186-F5	0188	0412
626 II 2.0i	GC	FE	2.0	74	03.83-09.87	Fg.Nr. 700001->	1	1	550	OZA25-F1	0187	1951
626 III 2.0i	GV	FE	2.0	66	10.88-10.92	Fg.Nr. 200001->	1	2	550	OZA25-F12	0198	1951
626 III 2.0i	GD	FE	2.0	66	09.87-10.90	Fg.Nr. 500001->	1	2	550	OZA25-F12	0198	1951
626 III 2.0i	GD	FE	2.0	66	09.87-10.90	Fg.Nr.-> 500000	1	1	550	OZA25-F3	0176	1951
626 III 2.0i	GV	FE	2.0	66	10.88-10.92	Fg.Nr.-> 200000	1	1	550	OZA25-F3	0176	1951
626 IV 1.8i 16V HB	GE	FP	1.8	66	07.95-03.97		4	31	280	OZA74-F2	0433	1952
626 IV 1.8i 16V	GE	FP	1.8	66	07.95-03.97		4	31	280	OZA74-F2	0433	1952
626 IV 1.8i 16V	GE	FP	1.8	66	06.94-06.95		4	31	250	OZA74-F3	0446	1952
626 IV 1.8i 16V HB	GE	FP	1.8	66	06.94-06.95		4	31	250	OZA74-F3	0446	1952
626 IV 1.8i 16V	GE	FP	1.8	77	08.91-03.97		4	31	480	OZA74-F1	0401	1952
626 IV 2.0i 16V	GE	FS	2.0	85	08.91-03.97		4	31	480	OZA74-F1	0401	1952
626 IV 2.0i	GE	FS	2.0	85	08.91-04.97		4	31	250	OZA253-F6	0122	1952
626 IV 2.0i 16V 4WD	GE	FS	2.0	85	09.91-03.97		4	31	480	OZA74-F1	0401	1952
626 IV 2.5i 24V	GE	KL	2.5	121	09.91-03.97		4	31	480	OZA74-F1	0401	1952
929 III 2.0i	HC	FE	2.0	85	06.87-12.88		1	1	550	OZA25-F3	0176	1951
929 III 3.0i 18V	HC	JE1	3.0	123	10.87-06.89		3	78	420	OZA21-F3	0256	0412
929 III 3.0i 18V	HC	JE01	3.0	140	12.86-06.89		3	78	420	OZA21-F3	0256	0412
MX-3 1.6i	EC	B69	1.6	65	07.91-		1	9	450	OZA401-E55	0143	1951
MX-6 2.0i	GE	FS	2.0	85	91- 97		4	31	250	OZA253-F6	0122	1952

Fg = Chassis No.

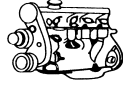

e kW



① ② ③

ORDER
No. No. STOCK
No. No. SIZES
A. L. No.**MAZDA**

MX-6 2.5i 24V	GE	KL	2.5	121	07.91-06.97		4	31	480	OZA74-F1	0401	1952
Xedos 6 2.0i 24V	CA	KF1	2.0	105	01.92-03.94		4	31	480	OZA74-F1	0401	1952
Xedos 9 2.3i 24V	TA	KJ-ZEM Miller-Cycle	2.3	155	06.96-07.98		3	15	450	OZA186-F7	0457	0412
Xedos 9 2.3i 24V	TA	KJ-ZEM Miller-Cycle	2.3	155-162	12.94-05.96		3	15	450	OZA186-F7	0457	0412

MERCEDES

190E 1.7	W201	M102.919	1.7	77	05.92-08.93	P	3	20	510	OZA446-E7	1872	0412
190E 1.8	W201	M102.910	1.8	80	04.90-08.93		3	20	510	OZA446-E7	1872	0412
190E 1.9	W201	M102.924	1.9	75-77	01.86-12.89		3	21	315	OZA446-E13	1826	0412
190E 2.0	W201	M102.962/ 236839->	2.0	87-90	09.89-08.93		3	20	510	OZA446-E7	1872	0412
190E 2.0	W201	M102.962/ 122336->	2.0	87-90	09.89-08.93		3	20	510	OZA446-E7	1872	0412
190E 2.0	W201	M102.962	2.0	87-90	09.85-09.89	->A528957	3	20	510	OZA446-E7	1872	0412
190E 2.3	W201	M102.985	2.3	97-100	09.86-09.89	->A528957	3	20	760	OZA446-E14	1837	0412
190E 2.3	W201	M102.985/ 033730->	2.3	97-100	09.89-08.93		3	20	510	OZA446-E7	1872	0412
190E 2.3	W201	M102.985/ 080065->	2.3	97-100	09.89-08.93		3	20	510	OZA446-E7	1872	0412
190E 2.3-16V	W201	M102.983	2.3	125-130	09.85-08.88		3	20	760	OZA446-E14	1837	0412
190E 2.5-16V Evolution I	W201	M102.991	2.5	143	03.89-04.90		3	21	315	OZA446-E13	1826	0412
190E 2.5-16V	W201	M102.990	2.5	143-150	09.88-08.93		3	21	315	OZA446-E13	1826	0412
190E 2.5-16V Evolution II	W201	M102.992	2.5	173	05.90-08.93		3	21	315	OZA446-E13	1826	0412
190E 2.6	W201	M103.942	2.6	118-122	09.86-08.93		3	21	315	OZA446-E13	1826	0412
200 E	W124	M102.922	2.0	77-80	01.86-08.89		3	20	760	OZA446-E14	1837	0412
200 E	W124	M102.963	2.0	87-90	09.88-09.89		3	20	760	OZA446-E14	1837	0412
200 E	W124	M102.963/036266->	2.0	87-90	09.89-08.92		3	20	510	OZA446-E7	1872	0412
200 E	W124	M102.963/009690->	2.0	87-90	09.89-08.92		3	20	510	OZA446-E7	1872	0412
200 E	W124	M102.963	2.0	87-90	09.88-08.92		3	20	510	OZA446-E7	1872	0412
200 TE	W124	M102.963	2.0	87-90	09.88-08.92		3	20	510	OZA446-E7	1872	0412
200 TE	W124	M102.962	2.0	90	09.88-12.89		3	20	510	OZA446-E7	1872	0412
200 E Cabrio	W124	M111.940	2.0	100	07.93-		4	41	770	OZA527-E10	0263	1919
200 E	W124	M111.940	2.0	100	07.93-06.95		4	41	770	OZA527-E10	0263	1919
200 E Coupe	W124	M111.940	2.0	100	07.93-06.96		4	41	770	OZA527-E10	0263	1919
200 E	W124	M111.940	2.0	100	07.93-06.95		4	41	770	OZA527-E10	0263	1919
200 E	W124	M111.940	2.0	100	09.92-06.93		4	41	770	OZA527-E10	0263	1919
200 E Coupe	W124	M111.940	2.0	100	07.93-06.96		4	41	770	OZA527-E10	0263	1919
200 E Cabrio	W124	M111.940	2.0	100	07.93-		4	41	770	OZA527-E10	0263	1919
200 TE	W124	M111.940	2.0	100	07.93-05.96		4	41	770	OZA527-E10	0263	1919
220 E	W124	M111.960	2.2	110	07.93-06.96		4	41	770	OZA527-E10	0263	1919
220 E	W124	M111.960	2.2	110	07.93-06.95		4	41	770	OZA527-E10	0263	1919
220 E	W124	M111.960	2.2	110	09.92-06.93		4	41	770	OZA527-E10	0263	1919
220 E Cabrio Cabrio	W124	M111.960	2.2	110	07.93-		4	41	770	OZA527-E10	0263	1919
220 E Coupe Coupe	W124	M111.960	2.2	110	07.93-06.96		4	41	770	OZA527-E10	0263	1919
220 TE	W124	M111.960	2.2	110	07.93-05.96		4	41	770	OZA527-E10	0263	1919
230 CE Coupe	W124	M102.982	2.3	97-100	03.87-08.88		3	20	760	OZA446-E14	1837	0412
230 CE Coupe	W124	M102.982	2.3	97-100	09.88-08.92		3	20	510	OZA446-E7	1872	0412
230 E	W124	M102.982	2.3	97-100	05.85-09.89		3	20	760	OZA446-E14	1837	0412
230 E	W124	M102.982/146597->	2.3	97-100	09.89-08.92		3	20	510	OZA446-E7	1872	0412
230 E	W124	M102.982/147102->	2.3	97-100	09.89-08.92		3	20	510	OZA446-E7	1872	0412
230 TE	W124	M102.982	2.3	97-100	09.88-08.92		3	20	510	OZA446-E7	1872	0412
260 E	W124	M103.940	2.6	118-122	09.85-08.92		3	20	760	OZA446-E14	1837	0412
280 E	W124	M104.942	2.8	142-145	06.93-06.95		4	41	750	OZA448-E38	0160	1952
280 E	W124	M104.942	2.8	145	10.92-06.93		4	41	750	OZA448-E38	0160	1952
300 TE 4MATIC	W124	M103.985	3.0	132-138	09.86-06.93		3	20	760	OZA446-E14	1837	0412
300 CE Coupe	W124	M103.983	3.0	132-138	03.87-08.92		3	20	760	OZA446-E14	1837	0412

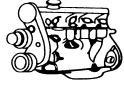

ℓ kW



① ② ③

ORDER
STOCK
 No. No. L.No.
MERCEDES

300 CE Coupe	W124	M103.983	3.0	132-138	03.87-08.92		3	20	760	OZA446-E14	1837	0412
300 E	W124	M103.983	3.0	132-138	09.85-08.92		3	20	760	OZA446-E14	1837	0412
300 SL	W107	M103.982	3.0	132-138	09.85-08.89		3	20	760	OZA446-E14	1837	0412
300 TE	W124	M103.983	3.0	132-138	01.86-08.92		3	20	760	OZA446-E14	1837	0412
300 E 24V	W124	M104.980	3.0	162	09.89-08.92		3	20	760	OZA446-E14	1837	0412
300 TE 24V	W124	M104.980	3.0	162	09.89-08.92		3	20	760	OZA446-E14	1837	0412
300 CE 24V Cabrio	W124	M104.980	3.0	162	04.92-06.93		3	20	760	OZA446-E14	1837	0412
300 CE 24V Coupe	W124	M104.980	3.0	162	09.89-08.92		3	20	760	OZA446-E14	1837	0412
320 E	W124	M 104.992	3.2	162	06.93-06.95		4	41	750	OZA448-E38	0160	1952
400 E	W124	M119.975	4.2	205	09.91-06.93	-> B 840528	4	34	338	OZA384-E40	0484	1952
400 SE,SEL	W140	M119.971	4.2	210	02.91-05.93	-> A 100180	4	34	338	OZA384-E40	0484	1952
500 SE,SEL	W140	M119.970	5.0	235-240	02.91-05.93		4	34	338	OZA384-E40	0484	1952
500 E	W124	M119.974	5.0	240	01.91-06.93		4	34	338	OZA384-E40	0484	1952
A 150	W169		1.5	70	09.04-		4	89	300	OZA571-C10	1836	---
A 150	W169		1.5	70	09.04-		4	89	300	OZA571-C10	1836	---
A 150	C169		1.5	70	09.04-		4	89	300	OZA571-C10	1836	---
A 150	C169		1.5	70	09.04-		4	89	300	OZA571-C10	1836	---
A 170	W169		1.7	85	09.04-		4	89	300	OZA571-C10	1836	---
A 170	W169		1.7	85	09.04-		4	89	300	OZA571-C10	1836	---
A 170	C169		1.7	85	09.04-		4	89	300	OZA571-C10	1836	---
A 170	C169		1.7	85	09.04-		4	89	300	OZA571-C10	1836	---
A 200	W169		2.0	110	09.04-		4	89	300	OZA571-C10	1836	---
A 200	W169		2.0	110	09.04-		4	89	300	OZA571-C10	1836	---
A 200	C169		2.0	110	09.04-		4	89	300	OZA571-C10	1836	---
A 200	C169		2.0	110	09.04-		4	89	300	OZA571-C10	1836	---
C 180	W202	M111.920xx050884->	1.8	90	03.93-		4	47	830	OZA527-E13	0285	1919
C 180	W202	M111.920xx117656->	1.8	90	03.93-		4	47	830	OZA527-E13	0285	1919
C 180	W202	->M111.920xx050883	1.8	90	03.93-		4	47	830	OZA527-E13	0285	1919
C 180	W202	->M111.920xx117655	1.8	90	03.93-		4	47	830	OZA527-E13	0285	1919
C 180	W202	->M111.920xx050883	1.8	90	03.93-		4	39	875	OZA527-E6	0463	1919
C 180	W202	->M111.920xx117655	1.8	90	03.93-		4	39	875	OZA527-E6	0463	1919
C 180 T	W202	M111.921xx007269->	1.8	90	05.96-		4	47	1145	OZA448-E29	0182	1952
C 180 T	W202	M111.921xx004127->	1.8	90	05.96-		4	47	1145	OZA448-E29	0182	1952
C 180 T	W202	M111.920 ->	1.8	90	05.96-		4	47	985	OZA448-E45	0206	1952
C 180 T	W202	M111.920xx007268										
C 180 T	W202	M111.920 ->	1.8	90	05.96-		4	47	985	OZA448-E45	0206	1952
C 180 T	W202	M111.921xx004126										
C 180 T	W202	->M111.920xx117655	1.8	90	05.96-		4	47	830	OZA527-E13	0285	1919
C 180 T	W202	M111.920xx050884->	1.8	90	05.96-		4	47	830	OZA527-E13	0285	1919
C 180 T	W202	->M111.920xx050883	1.8	90	05.96-		4	47	830	OZA527-E13	0285	1919
C 180 T	W202	M111.920xx117656->	1.8	90	05.96-		4	47	830	OZA527-E13	0285	1919
C 180 T	W202	->M111.920xx117655	1.8	90	05.96-		4	39	875	OZA527-E6	0463	1919
C 180 T	W202	->M111.920xx050883	1.8	90	05.96-		4	39	875	OZA527-E6	0463	1919
C 200	W202	M111.941, M111.945 ->	2.0	100	01.94-		4	47	985	OZA448-E45	0206	1952
C 200	W202	->M111.941xx015981	2.0	100	01.94-		4	47	830	OZA527-E13	0285	1919
C 200	W202	M111.941xx014846->	2.0	100	01.94-		4	47	830	OZA527-E13	0285	1919
C 200	W202	->M111.941xx014845	2.0	100	01.94-		4	47	830	OZA527-E13	0285	1919
C 200	W202	M111.941...->	2.0	100	01.94-		4	47	830	OZA527-E13	0285	1919
C 200	W202	->M111.941xx014845	2.0	100	01.94-		4	39	875	OZA527-E6	0463	1919
C 200	W202	->M111.941xx015981	2.0	100	01.94-		4	39	875	OZA527-E6	0463	1919
C 200 Kompressor	W202	M111.944	2.0	132-141	09.95-	① GR P	4	47	985	OZA448-E45	0206	1952
C 200	W202	M111.961 017342->	2.2	110	03.93-09.96		4	47	830	OZA527-E13	0285	1919

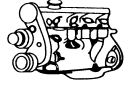

e kW



① ② ③

ORDER
No. No. STOCK
REVISION
L. No.**MERCEDES**

C 200	W202	M111.961 050896->	2.2	110	03.93-09.96			4	47	830	OZA527-E13	0285	1919
C 200 T	W202	M111.945xx001913->	2.0	100	05.96-			4	47	1145	OZA448-E29	0182	1952
C 200 T	W202	M111.945xx003753->	2.0	100	05.96-			4	47	1145	OZA448-E29	0182	1952
C 200 T	W202	M111.941, -> M111.945xx001912	2.0	100	05.96-			4	47	985	OZA448-E45	0206	1952
C 200 T	W202	M111.941, M111.945xx003752	2.0	100	05.96-			4	47	985	OZA448-E45	0206	1952
C 200 T	W202	->M111.941xx014845	2.0	100	05.96-			4	47	830	OZA527-E13	0285	1919
C 200 T	W202	M111.945xx015982->	2.0	100	05.96-			4	47	830	OZA527-E13	0285	1919
C 200 T	W202	M111.941xx014846->	2.0	100	05.96-			4	47	830	OZA527-E13	0285	1919
C 200 T	W202	->M111.941xx015891	2.0	100	05.96-			4	47	830	OZA527-E13	0285	1919
C 200 T	W202	->M111.941xx014845	2.0	100	05.96-			4	39	875	OZA527-E6	0463	1919
C 200 T	W202	->M111.941xx015981	2.0	100	05.96-			4	39	875	OZA527-E6	0463	1919
C 200 T Kompressor	W202	M111.944 000055->	2.0	141	06.97-			4	47	1145	OZA448-E29	0182	1952
C 200 T Kompressor	W202	M111.944 000055->	2.0	141	06.97-			4	47	1145	OZA448-E29	0182	1952
C 200 T Kompressor	W202	M111.944 003873->	2.0	141	06.97-			4	47	1145	OZA448-E29	0182	1952
C 200 T Kompressor	W202	M111.944 000055->	2.0	141	06.97-			4	47	1145	OZA448-E29	0182	1952
C 200 T Kompressor	W202	M111.944 003873->	2.0	141	06.97-			4	47	1145	OZA448-E29	0182	1952
C 200 T Kompressor	W202	M111.944 003873->	2.0	141	06.97-			4	47	1145	OZA448-E29	0182	1952
C 200 T Kompressor	W202	M111.944 000055->	2.0	141	06.97-			4	47	1145	OZA448-E29	0182	1952
C 200 T Kompressor	W202	M111.944 003873->	2.0	141	06.97-			4	47	1145	OZA448-E29	0182	1952
C 220	W202	M111.961 ->017341	2.2	110	03.93-09.96			4	47	830	OZA527-E13	0285	1919
C 220	W202	M111.961 ->050895	2.2	110	03.93-09.96			4	47	830	OZA527-E13	0285	1919
C 220	W202	M111.961 ->050895	2.2	110	03.93-09.96			4	39	875	OZA527-E6	0463	1919
C 220	W202	M111.961 ->017341	2.2	110	03.93-09.96			4	39	875	OZA527-E6	0463	1919
C 230	W202	M111.974	2.3	110	09.96-05.97			4	47	985	OZA448-E45	0206	1952
C 230 Kompressor	W202	M111.975	2.3	142	09.95-			4	47	985	OZA448-E45	0206	1952
C 230 T	W202	M111.974 001872->	2.3	110	05.96-05.97			4	47	1145	OZA448-E29	0182	1952
C 230 T	W202	M111.974 004992->	2.3	110	05.96-05.97			4	47	1145	OZA448-E29	0182	1952
C 230 T	W202	M111.974 ->001871	2.3	110	05.96-05.97			4	47	985	OZA448-E45	0206	1952
C 230 T	W202	M111.974 ->004991	2.3	110	05.96-05.97			4	47	985	OZA448-E45	0206	1952
C 230 T Kompressor	W202	M111.975 000556->	2.3	142	06.97-			4	47	1145	OZA448-E29	0182	1952
C 230 T Kompressor	W202	M111.975 005800->	2.3	142	06.97-			4	47	1145	OZA448-E29	0182	1952
C 230 T Kompressor	W202	M111.975 ->000555	2.3	142	06.97-			4	47	985	OZA448-E45	0206	1952
C 230 T Kompressor	W202	M111.975 ->005799	2.3	142	06.97-			4	47	985	OZA448-E45	0206	1952
C 240	W202	M112.910	2.4	125	06.97-04.01			4	47	815	OZA447-E34	0482	1952
C 240 T	W202	M112.910	2.4	125	06.97-02.01			4	47	815	OZA447-E34	0482	1952
C 280	W202	M112.920	2.8	145	06.97-04.01			4	47	815	OZA447-E34	0482	1952
C 280 T	W202	M112.920	2.8	145	06.97-02.01			4	47	815	OZA447-E34	0482	1952
C 43 AMG	W202	M113.944	4.3	225	11.97-04.00			4	47	815	OZA447-E34	0482	1952
C 43 T AMG	W202	M113.944	4.3	225	10.97-02.01			4	47	815	OZA447-E34	0482	1952
CL 420	C140	M119.971	4.2	205	09.96-08.99	A 290166 ->		4	34	338	OZA384-E40	0484	1952
CL 500	C140	M119.970	5.0	235	06.93-09.95			4	34	338	OZA384-E40	0484	1952
CL 500	C140	M119.980	5.0	235	09.96-08.99			4	34	338	OZA384-E40	0484	1952
CLK 200	W208	M111.945 003753->	2.0	100	06.97-			4	47	1145	OZA448-E29	0182	1952
CLK 200	W208	M111.945 001913->	2.0	100	06.97-			4	47	1145	OZA448-E29	0182	1952
CLK 200	W208	M111.945 ->003752	2.0	100	06.97-			4	47	985	OZA448-E45	0206	1952
CLK 200	W208	M111.945 ->001912	2.0	100	06.97-			4	47	985	OZA448-E45	0206	1952
CLK 200 Kompressor	W208	M111.944 000055->	2.0	141	09.97-			4	47	1145	OZA448-E29	0182	1952
CLK 200 Kompressor	W208	M111.944 003873->	2.0	141	09.97-			4	47	1145	OZA448-E29	0182	1952
CLK 200 Kompressor	W208	M111.944 ->003872	2.0	141	09.97-			4	47	985	OZA448-E45	0206	1952
CLK 200 Kompressor	W208	M111.944 ->000054	2.0	141	09.97-			4	47	985	OZA448-E45	0206	1952

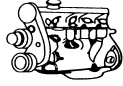

e kW



① ② ③

ORDER
NO. No.
STOCK
NO. No.
REVISION
DATE
MERCEDES

CLK 230 Kompressor	W208	M111.975 000556->	2.3	142	06.97-		4	47	1145	OZA448-E29	0182	1952
CLK 230 Kompressor	W208	M111.975 005800->	2.3	142	06.97-		4	47	1145	OZA448-E29	0182	1952
CLK 230 Kompressor	W208	M111.975 ->000555	2.3	142	06.97-		4	47	985	OZA448-E45	0206	1952
CLK 230 Kompressor	W208	M111.975 ->005799	2.3	142	06.97-		4	47	985	OZA448-E45	0206	1952
CLK 320 Cabrio	C208	M112.940	3.0	160	06.98-		4	47	815	OZA447-E34	0482	1952
CLK 320	C208	M112.940	3.2	160	06.97-		4	47	815	OZA447-E34	0482	1952
E 200 Kompressor	W210	M111.947	2.0	137	09.97-		4	47	1145	OZA448-E29	0182	1952
E 200 T Kompressor	W210	M111.947	2.0	137	09.97-		4	47	1145	OZA448-E29	0182	1952
E 240 T	W210	M112.911	2.4	125	09.97-		4	47	565	OZA447-E21	0216	1952
E 240 T	W210	M112.911	2.4	125	09.97-		4	47	625	OZA447-E22	0227	1952
E 280	W210	M112.921	2.8	150	03.97-		4	47	565	OZA447-E21	0216	1952
E 280 4MATIC	W210	M112.921	2.8	150	03.97-		4	47	625	OZA447-E22	0227	1952
E 280	W210	M112.921	2.8	150	03.97-		4	47	625	OZA447-E22	0227	1952
E 320	W210	M112.941	3.2	165	03.97-		4	47	565	OZA447-E21	0216	1952
E 320 4MATIC	W210	M112.941	3.2	165	06.97-		4	47	625	OZA447-E22	0227	1952
E 320	W210	M112.941	3.2	165	03.97-		4	47	625	OZA447-E22	0227	1952
E 320 T	W210	M112.941	3.2	165	03.97-		4	47	565	OZA447-E21	0216	1952
E 320 T 4MATIC	W210	M112.941	3.2	165	06.97-		4	47	625	OZA447-E22	0227	1952
E 320 T	W210	M112.941	3.2	165	03.97-		4	47	625	OZA447-E22	0227	1952
E 420	W210	M119.985	4.2	205	01.96-08.97		4	47	565	J 020295 ->	0216	1952
E 420	W210	M119.985	4.2	205	01.96-08.97		4	47	565	A132402 ->	0216	1952
E 420	W210	M119.985	4.2	205	01.96-08.97	->J 020294	4	47	565	OZA447-E21	0216	1952
E 420	W210	M119.985	4.2	205	01.96-08.97	-> A 132401	4	47	565	OZA447-E21	0216	1952
E 420	W210	M119.985	4.2	205	01.96-08.97		4	47	625	OZA447-E22	0227	1952
E 420	W210	M119.985	4.2	205	01.96-08.97		4	47	625	A132402 ->	0227	1952
E 420	W210	M119.985	4.2	205	01.96-08.97		4	47	625	J 020295 ->	0227	1952
E 420 T	W210	M119.985	4.2	205	05.96-08.97	->B132401	4	47	565	OZA447-E21	0216	1952
E 420 T	W210	M119.985	4.2	205	05.96-08.97	B132402->	4	47	625	OZA447-E22	0227	1952
E 430 T	W210	M113.940	4.3	205	09.97-		4	47	565	OZA447-E21	0216	1952
E 430 T	W210	M113.940	4.3	205	09.97-		4	47	625	OZA447-E22	0227	1952
E 55 T AMG	W210	M113.980	5.5	260	03.98-		4	47	625	OZA447-E22	0227	1952
E 55 T AMG	W210	M113.980	5.5	260	03.98-		4	47	565	OZA447-E21	0216	1952
E 60 AMG	W124		6.0	280	05.94-06.95	B 565714 -> B 840528	4	34	338	OZA384-E40	0484	1952
S 420	W140	M119.971	4.2	205-210	06.93-09.95	A 100180 ->	4	34	338	OZA384-E40	0484	1952
S 500	W140	M119.970	5.0	235-240	06.93-09.95	-> A 100180	4	34	338	OZA384-E40	0484	1952
SL 280	W220	M112.923	2.8	150	06.98-		4	47	625	OZA447-E22	0227	1952
SL 320	W220	M112.943	3.2	165	06.98-		4	47	625	OZA447-E22	0227	1952
SL 500	W220	M113.961	5.0	225	06.98-		4	47	625	OZA447-E22	0227	1952
SL 600	R129	M120.981	6.0	290	07.92-09.95		4	34	338	OZA384-E40	0484	1952
SL 600	R129	M120.983	6.0	290	07.92-09.95		4	34	338	OZA384-E40	0484	1952
SLK 200	R170	M111.946	2.0	100	09.96-03.00		4	47	280	OZA448-E54	0459	1952
SLK 200 Kompressor	R170	M111.943	2.0	135	10.96-03.00		4	47	280	OZA448-E54	0459	1952
SLK 230 Kompressor	R170	M111.973	2.3	142	09.96-03.00		4	47	280	OZA448-E54	0459	1952
Sprinter 214 2.3i		M111.984	2.3	105	04.00-		4	47	815	OZA447-E34	0482	1952
Sprinter 214 2.3i		M111.979	2.3	105	02.95-		4	47	815	OZA447-E34	0482	1952
Sprinter 314 2.3i		M111.979	2.3	105	02.95-		4	47	815	OZA447-E34	0482	1952
Sprinter 314 2.3i		M111.984	2.3	105	04.00-		4	47	815	OZA447-E34	0482	1952
Sprinter 414 2.3i		M111.979	2.3	105	02.95-		4	47	815	OZA447-E34	0482	1952
Sprinter 414 2.3i		M111.984	2.3	105	04.00-		4	47	815	OZA447-E34	0482	1952
MG												
MGF 1.6i 16V	K-Serie		1.6	82	10.01-03.02	Fg.Nr. ->YD 522572	4	33	590	OZA527-E9	0498	1919

Fg = Chassis No.

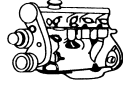

ℓ kW



① ② ③

ORDER
No. No. STOCK
No. No. SIZES
A. L. No.

MG												
MGF 1.8i 16V	18K4F	1.8	88	10.95-03.02	Fg.Nr. ->YD 522572	4	33	590	OZA527-E9	0498	1919	
MGF 1.8i 16V VVC	18K4K	1.8	107	10.95-03.02	Fg.Nr. ->YD 522572	4	33	590	OZA527-E9	0498	1919	
MGR 3.9i	V8	3.9	140	09.92-12.95		3	55	521	OTD3G-3A1	0453	- - -	
MITSUBISHI												
Carisma 1.6i 16V	4G92	1.6	66	05.95-02.99		4	71	340	OZA448-E52	0437	1952	
Carisma 1.6i 16V	4G92	1.6	73	05.97-		4	71	340	OZA448-E52	0437	1952	
Carisma 1.8i 16V	4G93	1.8	85	05.96-02.99		4	71	340	OZA448-E52	0437	1952	
Carisma 1.8i 16V GDI	4G93	1.8	92	05.97-02.99		4	76	400	OZA448-E53	0448	1952	
Carisma 1.8i 16V	4G93	1.8	103	05.95-04.97		4	71	340	OZA448-E52	0437	1952	
Colt 1.3	4G13	1.3	44-55	04.88-05.92		1	8	700	OZA401-E68	0428	1951	
Colt 1.3	G13B	1.3	49	06.86-06.88		1	8	700	OZA401-E68	0428	1951	
Colt 1.3i 12V	4G13	1.3	55	04.92-04.96		4	30	290	OZA85-M1	0165	1952	
Colt 1.5	G15B	1.5	51	06.86-05.87		1	8	700	OZA401-E68	0428	1951	
Colt 1.5i	4G15	1.5	62	04.88-05.92		1	8	700	OZA401-E68	0428	1951	
Colt 1.5 GLXI	4G15	1.5	66	04.88-04.89		1	8	550	OZA401-E63	0207	1951	
Colt 1.5i 8V	4G15	1.5	66	05.89-05.90		2	11	630	OZA428-E3	0121	1918	
Colt 1.5i 12V	4G13	1.5	66	06.90-05.92		2	11	630	OZA428-E3	0121	1918	
Colt 1.6i Turbo	4G32	1.6	77	07.86-04.88		1	8	700	OZA401-E68	0428	1951	
Colt IV 1.6i	4G92	1.6	66	12.91-12.96		4	30	320	OZA502-E34	0436	1952	
Colt IV 1.6i 16V	4G92 SOHC	1.6	83	12.91-11.95		4	30	320	OZA502-E34	0436	1952	
Colt IV 1.8i 16V	4G93 DOHC	1.8	103	12.91-11.95		4	30	320	OZA502-E34	0436	1952	
Cordia 1.8i Turbo	G62B	1.8	100	10.86-12.89		1	8	500	OZA401-E66	0406	1951	
Eclipse 2.0i	4G63	2.0	107	08.95-		4	30	285	OZA502-E36	0458	1952	
Galant 1.8i	4G37	1.8	62	11.87-05.90		1	8	650	OZA401-E67	0417	1951	
Galant 1.8i Sedan	4G37	1.8	66	11.87-10.92		2	12	580	OZA428-E2	0197	1918	
Galant 1.8i HB	4G37	1.8	66	11.88-10.92		2	12	580	OZA428-E2	0197	1918	
Galant 1.8i 16V	4G93	1.8	85	11.92-05.96		4	30	265	OZA502-E35	0447	1952	
Galant 1.8i 16V	4G93	1.8	93	12.93-05.96		4	30	265	OZA502-E35	0447	1952	
Galant 2.0i	G63B	2.0	66	06.86-12.87		1	8	655	OZA401-E53	0175	1951	
Galant 2.0i	4G63	2.0	75	06.84-12.87		1	8	655	OZA401-E53	0175	1951	
Galant 2.0i HB	4G63	2.0	80	11.88-05.91		1	8	445	OZA401-E54	0186	1951	
Galant 2.0i HB	4G63	2.0	80	06.91-10.92		2	12	460	OZA428-E4	0132	1918	
Galant 2.0i Sedan	4G63	2.0	80	11.88-05.91		1	8	445	OZA401-E54	0186	1951	
Galant 2.0i Sedan	4G63	2.0	80	06.91-10.92		2	12	460	OZA428-E4	0132	1918	
Galant 2.0i 16V	4G63	2.0	101	11.92-05.96		4	30	285	OZA502-E36	0458	1952	
Galant 2.0i	4G63T	2.0	107-110	06.84-11.87		1	8	650	OZA401-E67	0417	1951	
Galant 2.4i	G64B	2.4	82	07.85-11.87		1	8	650	OZA401-E67	0417	1951	
L300 2.0i	4G63	2.0	66	11.86-05.94		1	8	655	OZA401-E53	0175	1951	
L300 2.0i	4G63	2.0	66	11.86-05.94		1	8	655	OZA401-E53	0175	1951	
L300 2.0i	4G63	2.0	66	11.86-06.95		1	8	655	OZA401-E53	0175	1951	
Lancer 1.3	4G13	1.3	55	01.92-12.96		4	30	290	OZA85-M1	0165	1952	
Lancer 1.5	4G15	1.5	66	04.88-04.89		1	8	550	OZA401-E63	0207	1951	
Lancer 1.5 SW	4G15	1.5	66	04.88-04.89		1	8	550	OZA401-E63	0207	1951	
Lancer 1.5 8V	4G15	1.5	66	05.89-05.90		2	11	630	OZA428-E3	0121	1918	
Lancer 1.5 8V SW	4G15	1.5	66	09.88-12.91		2	11	630	OZA428-E3	0121	1918	
Lancer 1.5 12V HB	4G15	1.5	66	06.90-05.92		2	11	630	OZA428-E3	0121	1918	
Lancer 1.5 8V HB	4G15	1.5	66	05.89-05.90		2	11	630	OZA428-E3	0121	1918	
Lancer 1.5 12V	4G15	1.5	66	06.90-05.92		2	11	630	OZA428-E3	0121	1918	
Lancer 1.5	4G15	1.5	66	01.92-12.96		4	30	290	OZA85-M1	0165	1952	
Lancer 1.6i 16V 4WD	4G92 SOHC	1.6	83	06.92-07.95		4	30	320	OZA502-E34	0436	1952	
Lancer 1.6i 16V HB	4G92 SOHC	1.6	83	06.92-07.95		4	30	320	OZA502-E34	0436	1952	

Fg = Chassis No.

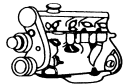

① ② ③

ORDER No. STOCK No. SERIAL No. PLATE No.

MITSUBISHI

Lancer 1.6i 16V	4G92 SOHC	1.6	83	01.93-12.96		4	30	320	OZA502-E34	0436	1952
Lancer 1.6i 16V 4WD	4G92	1.6	83	05.92-11.93		4	30	265	OZA502-E35	0447	1952
Lancer 1.6i SW	4G92	1.6	83	06.92-		4	30	285	OZA502-E36	0458	1952
Lancer 1.8i 16V	4G93 DOHC	1.8	100-103	05.92-11.95		4	30	320	OZA502-E34	0436	1952
Lancer 1.8i 16V HB	4G93 DOHC	1.8	103	06.92-07.95		4	30	320	OZA502-E34	0436	1952
Space Runner 1.8i	4G93	1.8	85	06.96-08.99		4	30	285	OZA502-E36	0458	1952
Space Runner 1.8i	4G93	1.8	90	10.91-08.99		4	30	285	OZA502-E36	0458	1952
Space Wagon 2.0i 16V	4G63 SOHC	2.0	98	10.92-10.98		4	30	320	OZA502-E34	0436	1952
Tredia 2.0i 4WD	G63B	2.0	75	09.86-12.89		1	8	500	OZA401-E66	0406	1951

NISSAN

100 NX 1.6i 16V	B13	GA16DE	1.6	75-81	10.92-10.94		3	23	380	OZA446-E45	0155	0412
350 Z 3.5i V6 24V		VQ35DE	3.5	180	10.03-		4	70	371	OZA544-N8	1804	1952
350 Z 3.5i V6 24V		VQ35DE	3.5	180	10.03-		4	88	500	OZA544-R1	1857	1952
Bluebird 1.8	T72	CA18D	1.8	95	02.89-		1	3	200	OZA401-E51	0142	1951
Bluebird 1.8	T12	CA18D	1.8	99	11.88-		1	3	200	OZA401-E51	0142	1951
Bluebird 2.0	U11	CA20E	2.0	72	04.86-		1	3	170	OZA401-E50	0131	1951
Bluebird 2.0	T72	CA20E	2.0	72	09.88-		1	3	170	OZA401-E50	0131	1951
Bluebird 2.0	T12	CA20E	2.0	72	03.86-		1	3	170	OZA401-E50	0131	1951
Maxima 3.0i	J30	VG30E	3.0	125	10.88-06.94		3	60	810	OTD2F-3K1	1907	---
Micra 1.0	K10	MA10S	1.0	37	12.82-12.89		1	3	170	OZA401-E50	0131	1951
Micra 1.0	K10	MA10S	1.0	40	05.82-12.89		1	3	170	OZA401-E50	0131	1951
Micra 1.0i 16V	K11E	CG10DE	1.0	40	08.92-09.00		3	23	380	OZA446-E45	0155	0412
Micra 1.0i 16V	K11	CG10DE	1.0	44	09.00-		4	70	350	OZA448-E58	1909	1952
Micra 1.2	K10	MA12S	1.2	40	07.86-07.92		1	3	170	OZA401-E50	0131	1951
Micra 1.3i 16V	K11E	CG13DE	1.3	55	08.92-07.00		3	23	380	OZA446-E45	0155	0412
Micra 1.4i 16V	K11	CGA3DE	1.4	60	09.00-		4	70	350	OZA448-E58	1909	1952
Pathfinder 2.4	D21	Z24i	2.4	77	10.88-04.92		1	3	200	OZA401-E51	0142	1951
Pathfinder 2.4	D21	KA24E	2.4	93	04.92-05.94	(SF) (S) (CH)	1	3	170	OZA401-E50	0131	1951
Pick Up 2.4	D21	Z24i	2.4	77	10.88-04.92		1	3	200	OZA401-E51	0142	1951
Pick Up 2.4	D21	KA24E	2.4	93	04.92-05.94	(SF) (S) (CH)	1	3	170	OZA401-E50	0131	1951
Prarie 2.0i	M11	CA20E	2.0	72	10.88-04.92		1	3	170	OZA401-E50	0131	1951
Primera 1.6	W10	GA16DS	1.6	66	07.90-04.93		1	3	200	OZA401-E51	0142	1951
Primera 1.6i 16V	W10	GA16DE	1.6	75	04.93-12.97		3	23	380	OZA446-E45	0155	0412
Primera 2.0i 16V LB	P10	SR20DI	2.0	85	06.90-01.96		3	60	810	OTD2F-3K1	1907	---
Primera 2.0i 16V	P10	SR20DI	2.0	85	06.90-01.96		3	60	810	OTD2F-3K1	1907	---
Primera 2.0 GT	P10	SR20DE	2.0	110	06.90-01.96		3	60	810	OTD2F-3K1	1907	---
Santana 1.8i		JN SOHC	1.8	67	01.84-		1	3	472	OZA401-E2	1802	1951
Santana 2.0i			2.0	77	01.84-01.87		1	3	472	OZA401-E2	1802	1951
Serena 1.6i 16V	C23M	GA16DE	1.6	71	07.92-		4	34	300	OZA384-E39	0473	1952
Sunny 1.4i 16V	N14	GA14DS	1.4	55	10.90-10.92		1	3	200	OZA401-E51	0142	1951
Sunny 1.4i 16V Sedan	N14	GA14DS	1.4	55	10.90-05.95		1	3	200	OZA401-E51	0142	1951
Sunny 1.4i 16V HB	N14	GA14DS	1.4	55	10.90-05.95		1	3	200	OZA401-E51	0142	1951
Sunny 1.4i 16V LB	N14	GA14DS	1.4	55	10.90-05.95		1	3	200	OZA401-E51	0142	1951
Sunny 1.4i 16V	N14	GA14DE	1.4	55	10.92-05.95		3	23	380	OZA446-E45	0155	0412
Sunny 1.4i 16V HB	N14	GA14DE	1.4	60-64	10.92-05.95		3	23	380	OZA446-E45	0155	0412
Sunny 1.6i HB	N13	E16i	1.6	54	06.86-10.90		1	3	200	OZA401-E51	0142	1951
Sunny 1.6	B13	GA16DS	1.6	66	10.90-10.92		1	3	200	OZA401-E51	0142	1951
Sunny 1.6	N14	GA16DS	1.6	66	10.90-10.92		1	3	200	OZA401-E51	0142	1951
Sunny 1.6	Y10	GA16DS	1.6	66	05.92-10.92		1	3	200	OZA401-E51	0142	1951
Sunny 1.6i 16V	B12	CA16i	1.6	81	10.88-		1	3	200	OZA401-E51	0142	1951
Sunny 1.6i 16V	N14	GA16DE	1.6	75-81	10.92-05.95		3	23	380	OZA446-E45	0155	0412



ℓ kW



① ② ③

ORDER
No. No.
STOCK
No. No.
REVISIONS
A. L. No.**NISSAN**

Sunny 1.6i 16V 4x4	Y10	GA16DE	1.6	75-81	10.92-07.95		3	23	380	OZA446-E45	0155	0412
Sunny 1.8	B12	CA18D	1.8	92	10.88-		1	3	200	OZA401-E51	0142	1951
Terrano I 2.4i	WD21	Z24i	2.4	77	08.87-07.92		1	3	200	OZA401-E51	0142	1951
Vanette 1.6i 16V	HC23	GA16DE	1.6	71	07.92-		4	34	300	OZA384-E39	0473	1952
Vanette 2.4i	GC22	Z24i	2.4	77	09.86-09.87		1	3	170	OZA401-E50	0131	1951
Vanette 2.4i	GC22	Z24i	2.4	77	09.87-		1	3	200	OZA401-E51	0142	1951

OPEL

Ascona 1.6i	C	E16NZ	1.6	55	09.87-08.88		1	6	320	OZA401-E6	1882	1951
Ascona 1.6i	C	C16NZ ; C16LZ	1.6	55	09.86-08.88		1	6	320	OZA401-E6	1882	1951
Ascona 1.6i	C	E16NZ	1.6	55	09.87-08.88		1	6	320	OZA401-E6	1882	1951
Ascona 1.8E	C	C18NE	1.8	74	01.85-08.86		3	14	885	OZA446-E6	1861	0412
Ascona 2.0i	C	20NE	2.0	85	09.86-08.88		3	14	885	OZA446-E6	1861	0412
Astra 1.2i 16V	G	X12XE	1.2	48	09.98-09.00		4	72	510	OZA447-E26	0405	1952
Astra 1.2i 16V Caravan	G	X12XE	1.2	48	02.98-09.00		4	72	510	OZA447-E26	0405	1952
Astra 1.4i	F	C14NZ OHC	1.4	44	09.91-	->T2576507, T5076960	1	6	320	OZA401-E6	1882	1951
Astra 1.4i	F	C14NZ OHC	1.4	44	09.91-	T2576508, T5076961->	1	6	320	OZA401-E6	1882	1951
Astra 1.4i Van	F	C14NZ OHC	1.4	44	03.93-02.98		1	6	320	OZA401-E6	1882	1951
Astra 1.4i	F	14SE, C14SE OHC	1.4	60	03.92-03.96	->T2576507, T5076960	1	6	320	OZA401-E6	1882	1951
Astra 1.4i	F	14SE, C14SE OHC	1.4	60	03.92-03.96	T2576508, T5076961->	1	6	320	OZA401-E6	1882	1951
Astra 1.4i 16V	F	X14XE DOHC	1.4	66	04.96-		1	6	320	OZA401-E6	1882	1951
Astra 1.4i 16V	G	X14XE	1.4	66	03.98-		4	42	320	OZA448-E49	0404	1952
Astra 1.6i Van	F	X16SZ OHC	1.6	52	02.93-07.96		1	6	320	OZA401-E6	1882	1951
Astra 1.6i	F	X16SZ OHC	1.6	52	09.92-03.96	T2576508, T5076961->	1	6	320	OZA401-E6	1882	1951
Astra 1.6i	F	X16SZ OHC	1.6	52	09.92-03.96	->T2576507, T5076960	1	6	320	OZA401-E6	1882	1951
Astra 1.6i	F	X16SZR OHC	1.6	55	04.96-	->T2576507, T5076960	1	6	320	OZA401-E6	1882	1951
Astra 1.6i	G	X16SZR	1.6	55	09.98-09.00		1	6	320	OZA401-E6	1882	1951
Astra 1.6i Caravan	G	X16SZR	1.6	55	02.98-09.00		1	6	320	OZA401-E6	1882	1951
Astra 1.6i Van	G	X16SZR	1.6	55	01.99-		1	6	320	OZA401-E6	1882	1951
Astra 1.6i	F	X16SZR OHC	1.6	55	04.96-	T2576508, T5076961->	1	6	320	OZA401-E6	1882	1951
Astra 1.6i CC	G	X16SZR	1.6	55	02.98-09.00		1	6	320	OZA401-E6	1882	1951
Astra 1.6i Van	F	C16NZ	1.6	55	03.93-02.98		1	6	320	OZA401-E6	1882	1951
Astra 1.6i	F	C16NZ, E16NZ OHC	1.6	55-60	09.91-	->T2576507, T5076960	1	6	320	OZA401-E6	1882	1951
Astra 1.6i	F	C16NT, E16NZ OHC	1.6	55-60	09.91-	T2576508, T5076961->	1	6	320	OZA401-E6	1882	1951
Astra 1.6i	F	X16XEL DOHC	1.6	74	09.95-	->W1285446; W5276825; W7154258	1	6	320	OZA401-E6	1882	1951
Astra 1.6i	F	C16SE OHC	1.6	74	03.92	T2576508, T5076961->	1	6	320	OZA401-E6	1882	1951
Astra 1.6i	F	C16SE OHC	1.6	74	03.92-	->T2576507, T5076960	1	6	320	OZA401-E6	1882	1951
Astra 1.6i 16V	G	X16XEL	1.6	74	03.98-		4	42	320	OZA448-E49	0404	1952
Astra 1.8i	F	C18NZ OHC	1.8	66	09.91-	->T2576507, T5076960	1	6	320	OZA401-E6	1882	1951
Astra 1.8i	F	C18NZ OHC	1.8	66	09.91	T2576508, T5076961->	1	6	320	OZA401-E6	1882	1951
Astra 1.8i 16V	F	C18XEL	1.8	85	08.95-		4	53	708	OTA7L-3C3	0442	---
Astra 1.8i 16V	G	X18XE	1.8	85	03.99-		4	53	770	OTA7N-5A2	1938	---
Astra 1.8i 16V	G	X18XE1	1.8	85	09.98-09.00		4	53	770	OTA7N-5A2	1938	---
Astra 1.8i 16V Caravan	G	X18XE1	1.8	85	02.98-09.00		4	53	770	OTA7N-5A2	1938	---
Astra 1.8i 16V Coupe	G	X18XE1	1.8	85	03.00-10.00		4	53	770	OTA7N-5A2	1938	---
Astra 1.8i 16V	F	C18XE, XEV	1.8	92	09.92-08.95		4	53	828	OTA7H-3C1	1954	---
Astra 1.8i 16V	F	C18XE, XEV	1.8	92	09.95-		4	53	708	OTA7L-3C3	0442	---
Astra 1.8i 16V	G	Z18XE	1.8	92	01.00-		4	74	741	OZA334-SZ1	0485	1952
Astra 1.8i 16V	G	Z18XE	1.8	92	01.00-		4	74	571	OZA334-SZ2	0496	1952
Astra 1.8i 16V	G	Z18XE	1.8	92	01.00-		4	74	401	OZA334-SZ3	0407	1952

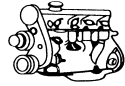

e kW



① ② ③

ORDER
STOCK
 No. No. L.No.
OPEL

Astra 2.0i	F	C20NE	2.0	85	03.92-09.98		3	14	885	OZA446-E6	1861	0412
Astra 2.0i Cabrio	F	C20NE	2.0	85	03.93-10.94		3	14	885	OZA446-E6	1861	0412
Astra 2.0i Caravan	F	C20NE	2.0	85	09.91-07.94		3	14	885	OZA446-E6	1861	0412
Astra 2.0i CC	F	C20NE	2.0	85	09.91-01.98		3	14	885	OZA446-E6	1861	0412
Astra 2.0i 16V	F	X20XEV	2.0	100	01.95-07.95		4	53	828	OTA7H-3C1	1954	---
Astra 2.0i 16V	F	X20XEV	2.0	100	08.95-		4	53	708	OTA7L-3C3	0442	---
Astra 2.0i 16V	G	X20XEV	2.0	100	03.99-		4	53	620	OTA7N-5A1	1920	---
Astra 2.0i 16V	F	C20XE	2.0	110	09.91-01.98		3	14	885	OZA446-E6	1861	0412
Astra 2.0i 16V Caravan	F	C20XE	2.0	110	03.93-01.98		3	14	885	OZA446-E6	1861	0412
Astra 2.0i 16V OPC CC	G	X20XER	2.0	118	11.99-09.02		4	53	770	OTA7N-5A2	1938	---
Astra 2.2i 16V	G	Z22SE	2.2	108	05.99-12.00		4	86	660	OZA531-GM1	1862	1952
Astra 2.2i 16V	G	Z22SE	2.2	108	01.01-		4	86	607	OZA531-GM6	1869	1952
Astra 2.2i 16V	G	Z22SE	2.2	108	05.01-	/	4	74	1245	OZA531-GM2	1863	1952
Astra 2.2i 16V	G	Z22SE	2.2	108	05.01-	/	4	74	1115	OZA531-GM3	1864	1952
Calibra 2.0i	A	C20NE	2.0	85	06.90-07.97		3	14	885	OZA446-E6	1861	0412
Calibra 2.0i 4x4	A	C20NE	2.0	85	06.90-07.97		3	14	885	OZA446-E6	1861	0412
Calibra 2.0i 16V	A	X20XEV	2.0	100	03.94-12.95		4	53	828	OTA7H-3C1	1954	---
Calibra 2.0i 16V	A	X20XEV	2.0	100	01.96-04.97		4	53	708	OTA7L-3C3	0442	---
Calibra 2.0i 16V	A	C20XE	2.0	110	06.90-02.94	->P1000345, N9999999	3	14	885	OZA446-E6	1861	0412
Calibra 2.0i 16V 4x4	A	C20XE	2.0	110	06.90-02.94	->P1000345, N9999999	3	14	885	OZA446-E6	1861	0412
Calibra 2.0i 16V Turbo	A	C20LET	2.0	150	03.92-03.97		3	14	1220	OZA446-E3	1866	0412
Calibra 2.5i V6	A	C25XE, X25XE	2.5	125	04.93-07.97		3	14	885	OZA446-E6	1861	0412
Combo 1.2i		12NZ, C12NZ OHC	1.2	33	07.94-		1	6	320	OZA401-E6	1882	1951
Combo 1.2i		X12SZ OHC	1.2	33	03.94-		1	6	320	OZA401-E6	1882	1951
Combo 1.4i		X14SZ	1.4	44	04.96-		1	6	320	OZA401-E6	1882	1951
Combo 1.4i		C14NZ OHC	1.4	44	07.94-03.96		1	6	320	OZA401-E6	1882	1951
Combo 1.4i		C14SE OHC	1.4	60	07.94-		1	6	320	OZA401-E6	1882	1951
Corsa 1.0i 12V	B	X10XE	1.0	40	03.97-09.00		4	72	510	OZA447-E26	0405	1952
Corsa 1.2i	B	X12SZ OHC	1.2	33	03.94-		1	6	320	OZA401-E6	1882	1951
Corsa 1.2i	A	C12NZ OHC	1.2	33	09.90-03.93		1	6	320	OZA401-E6	1882	1951
Corsa 1.2i	B	12NZ, C12NZ OHC	1.2	33	03.93-		1	6	320	OZA401-E6	1882	1951
Corsa 1.2i 16V	B	X12XE	1.2	48	09.97-09.00		4	72	510	OZA447-E26	0405	1952
Corsa 1.3i	A	C13N	1.3	44	09.85-03.93		1	6	320	OZA401-E6	1882	1951
Corsa 1.4i	B	X14SZ	1.4	40-44	04.96-		1	6	320	OZA401-E6	1882	1951
Corsa 1.4i	A	C14NZ	1.4	40-44	01.90-03.93		1	6	320	OZA401-E6	1882	1951
Corsa 1.4i Van	B	X14SZ	1.4	44	08.99-		1	6	320	OZA401-E6	1882	1951
Corsa 1.4i	B	C14NZ	1.4	44	03.93-03.96		1	6	320	OZA401-E6	1882	1951
Corsa 1.4i	B	C14SE	1.4	60	03.93-		1	6	320	OZA401-E6	1882	1951
Corsa 1.4i 16V	B	X14XE DOHC	1.4	66	09.94-	S3000001->	1	6	320	OZA401-E6	1882	1951
Corsa 1.4i 16V	B	X14XE DOHC	1.4	66	09.94-	T4124376, T6060014->	1	6	320	OZA401-E6	1882	1951
Corsa 1.4i 16V	B	X14XE DOHC	1.4	66	09.94-	S4000001, S6000001->	1	6	320	OZA401-E6	1882	1951
						T4124375, T606001						
Corsa 1.6i	A	C16NZ, E16NZ	1.6	55	04.89-03.93		1	6	320	OZA401-E6	1882	1951
Corsa 1.6 GSi	A	C16SEi	1.6	72	09.89-03.93		3	14	885	OZA446-E6	1861	0412
Corsa 1.6 GSi	A	E16SE	1.6	74	05.88-03.92		3	14	885	OZA446-E6	1861	0412
Corsa 1.6 GSi	A	C16SEi	1.6	74	02.92-03.93		3	14	885	OZA446-E6	1861	0412
Corsa 1.6i 16V	B	X16XE DOHC	1.6	78	09.94-	S3000001->	1	6	320	OZA401-E6	1882	1951
Corsa 1.6i 16V	B	X16XE DOHC	1.6	78	09.94-	T4124376, T6060014->	1	6	320	OZA401-E6	1882	1951
Corsa 1.6i 16V	B	X16XE DOHC	1.6	78	09.94-	S4000001, S6000001->	1	6	320	OZA401-E6	1882	1951
						T4124375, T606001						
Corsa 1.6i	B	C16XE DOHC	1.6	80	03.93-	S3000001->	1	6	320	OZA401-E6	1882	1951
Corsa 1.6i	B	C16XE DOHC	1.6	80	03.93-	T4124376, T6060014->	1	6	320	OZA401-E6	1882	1951

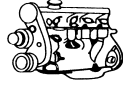

ℓ kW



① ② ③

ORDER
No. No.
STOCK
No. No.
REVISIONS
L. No.
OPEL

Corsa 1.6i	B	C16XE DOHC	1.6	80	03.93-	S4000001, S6000001-> T4124375, T606001	1	6	320	OZA401-E6	1882	1951
Corsa 1.8i 16V	C	Z18XE	1.8	92	01.01-		4	74	271	OZA334-SZ4	0418	1952
Frontera 2.0i	A	C20NE	2.0	85	09.91-		3	14	1220	OZA446-E3	1866	0412
Frontera 2.0i	A	X20SE OHC	2.0	85	02.95-		3	14	422	OZA446-E40	0193	0412
Frontera 2.2i 16V	A	X22XE DOHC	2.2	100	02.95-		3	14	422	OZA446-E40	0193	0412
Kadett 1.3N Van	E	13N, 13NB	1.3	44	09.84-07.89		1	6	320	OZA401-E6	1882	1951
Kadett 1.3N Combo	E	C13N	1.3	44	01.86-12.89		1	6	320	OZA401-E6	1882	1951
Kadett 1.3i	E	C13N	1.3	44	09.85-08.91		1	6	320	OZA401-E6	1882	1951
Kadett 1.4i	E	C14NZ	1.4	44	01.90-08.91		1	6	320	OZA401-E6	1882	1951
Kadett 1.6i Combo	E	C16NZ	1.6	55	08.91-07.94		1	6	320	OZA401-E6	1882	1951
Kadett 1.6i	E	C16LZ, C16NZ	1.6	55	09.86-08.91		1	6	320	OZA401-E6	1882	1951
Kadett 1.6i Van	E	C16NZ	1.6	55	08.89-09.93		1	6	320	OZA401-E6	1882	1951
Kadett 1.6i	E	E16NZ OHC I	1.6	55	09.87-08.91		1	6	320	OZA401-E6	1882	1951
Kadett 1.8i	E	C18NZ OHC II	1.8	66	09.90-08.91		1	6	320	OZA401-E6	1882	1951
Kadett 1.8i Van	E	C18NT	1.8	66	08.84-09.92		1	6	320	OZA401-E6	1882	1951
Kadett 1.8i Van	E	C18NT	1.8	66	08.84-09.92		3	14	885	OZA446-E6	1861	0412
Kadett 1.8i	E	C18NT, C18NZ	1.8	66	06.85-09.85		3	14	885	OZA446-E6	1861	0412
Kadett 1.8i	E	C18NE	1.8	74	10.85-08.86		3	14	885	OZA446-E6	1861	0412
Kadett 2.0i Caravan	E	C20NE	2.0	85	09.87-08.91		3	14	885	OZA446-E6	1861	0412
Kadett 2.0i	E	20NE	2.0	85	03.87-08.91		3	14	885	OZA446-E6	1861	0412
Kadett 2.0i Cabrio	E	C20NE	2.0	85	10.86-02.93		3	14	885	OZA446-E6	1861	0412
Kadett 2.0i	E	C20NE	2.0	85	03.87-08.91		3	14	885	OZA446-E6	1861	0412
Kadett 2.0i GSi	E	20NE	2.0	85	09.86-08.91		3	14	885	OZA446-E6	1861	0412
Kadett 2.0i Caravan	E	20NE	2.0	85	09.87-08.91		3	14	885	OZA446-E6	1861	0412
Kadett 2.0i Cabrio	E	20NE	2.0	85	10.86-02.93		3	14	885	OZA446-E6	1861	0412
Kadett 2.0i GSi	E	C20NE	2.0	85	09.86-08.91		3	14	885	OZA446-E6	1861	0412
Kadett 2.0i 16V GSi	E	C20XE, 20XEJ	2.0	110	03.88-08.91		3	14	885	OZA446-E6	1861	0412
Kadett 2.0i 16V GSi	E	20XE	2.0	115	03.88-08.91		3	14	885	OZA446-E6	1861	0412
Monza 3.0 GSE	A	C30LE	3.0	115	09.85-08.86		3	14	885	OZA446-E6	1861	0412
Omega 2.0i	A	C20NEF	2.0	74	09.90-03.94		3	14	1220	OZA446-E3	1866	0412
Omega 2.0i	A	20NE, C20NE OHC	2.0	85	09.86-03.94		3	14	1220	OZA446-E3	1866	0412
Omega 2.0i	B	X20SE OHC	2.0	85	01.94-		3	14	422	OZA446-E40	0193	0412
Omega 2.0i	B	20SE OHC	2.0	85	01.94-		3	14	225	OZA446-E41	0128	0412
Omega 2.0i 16V	B	X20XEV	2.0	100	01.94-02.95	OE	4	53	338	OTA7H-3C2	0420	---
Omega 2.0i 16V	B	X20XEV	2.0	100	02.95-	OE	4	53	338	OTA7L-3C4	0431	---
Omega 2.0i 16V	B	X20XEV	2.0	100	03.99-		4	53	620	OTA7N-5A1	1920	---
Omega 2.5i 24V	B	X25XE DOHC V6	2.5	125	01.94-		3	14	422	OZA446-E40	0193	0412
Omega 2.5i 24V	B	X25XE DOHC V6	2.5	125	01.94-08.94		3	14	422	OZA446-E40	0193	0412
Omega 2.6i	A	C26NE	2.6	110	09.90-03.94		3	14	885	OZA446-E6	1861	0412
Omega 3.0	A	C30LE	3.0	115	03.87-12.87		3	14	885	OZA446-E6	1861	0412
Omega 3.0 Caravan	A	C30NE	3.0	130	01.88-03.94		3	14	885	OZA446-E6	1861	0412
Omega 3000	A	C30NE	3.0	130	03.88-03.94		3	14	885	OZA446-E6	1861	0412
Omega 3000 24V	A	C30SEJ	3.0	147	09.89-03.94		3	14	885	OZA446-E6	1861	0412
Omega 3000 24V	A	C30SE	3.0	150	09.89-03.94		3	14	885	OZA446-E6	1861	0412
Omega 3.0i 24V	B	X30XE DOHC V6	3.0	155	01.94-08.94		3	14	422	OZA446-E40	0193	0412
Omega 3.0i 24V	B	X30XE DOHC V6	3.0	155	01.94-		3	14	422	OZA446-E40	0193	0412
Rekord 1.8i	E	C18NV OHC	1.8	74	05.85-08.86		3	14	1220	OZA446-E3	1866	0412
Senator 2.6i	B	C26NE	2.6	110	09.90-09.93		3	14	885	OZA446-E6	1861	0412
Senator 3.0i	B	C30LE	3.0	115	09.87-09.93	->M1000000	3	14	885	OZA446-E6	1861	0412
Senator 3.0i	A	C30LE	3.0	115	09.85-08.87		3	14	885	OZA446-E6	1861	0412
Senator 3.0i	B	C30NE	3.0	130	01.88-09.93		3	14	885	OZA446-E6	1861	0412

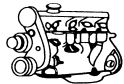

① ② ③

ORDER No. STOCK No. PART No.

OPEL

Senator 3.0i 24V	B	C30SE	3.0	150	09.89-09.93	->M1000000	3	14	885	OZA446-E6	1861	0412
Senator 3.6i	B	C3.6NE Irmscher	3.6	145	08.89-09.93		3	14	885	OZA446-E6	1861	0412
Signum 2.0i 16V Turbo		Z20NET	2.0	129	05.03-		4	87	1465	OZA531-GM16	1891	1952
Sintra 2.2i 16V		X22XE	2.2	141	11.96-04.99		3	14	885	OZA446-E6	1861	0412
Sintra 3.0i 24V		X30XE DOHC V6	3.0	148	09.96-		3	14	422	OZA446-E40	0193	0412
Speedster 2.2i 16V		Z22SE	2.2	108	05.99-12.00		4	86	660	OZA531-GM1	1862	1952
Speedster 2.2i 16V		Z22SE	2.2	108	01.01-		4	86	607	OZA531-GM6	1869	1952
Speedster 2.2i 16V		Z22SE	2.2	108	05.01-	/	4	74	1245	OZA531-GM2	1863	1952
Speedster 2.2i 16V		Z22SE	2.2	108	05.01-	/	4	74	1115	OZA531-GM3	1864	1952
Tigra 1.4i 16V		X14XE DOHC	1.4	66	09.94-	T4124376, T6060014->	1	6	320	OZA401-E6	1882	1951
Tigra 1.4i 16V		X14XE DOHC	1.4	66	09.94-	S4000001, S6000001->	1	6	320	OZA401-E6	1882	1951
						T4124375, T606001						
Tigra 1.4i 16V		X14XE DOHC	1.4	66	09.94-	S3000001->	1	6	320	OZA401-E6	1882	1951
Tigra 1.6i 16V		X16XE DOHC	1.6	78	09.94-	S3000001->	1	6	320	OZA401-E6	1882	1951
Tigra 1.6i 16V		X16XE DOHC	1.6	78	09.94-	S4000001, S6000001->	1	6	320	OZA401-E6	1882	1951
						T4124375, T606001						
Tigra 1.6i 16V		X16XE DOHC	1.6	78	09.94-	T4124376, T6060014->	1	6	320	OZA401-E6	1882	1951
Vectra 1.6i	A	X16SZ OHC	1.6	52	09.93-08.95		1	6	320	OZA401-E6	1882	1951
Vectra 1.6i	A	C16NZ, E16NZ OHC	1.6	55	09.88-08.95		1	6	320	OZA401-E6	1882	1951
Vectra 1.6i	B	X16SZR OHC	1.6	55	09.95-		1	6	320	OZA401-E6	1882	1951
Vectra 1.6i 16V	B	X16XEL DOHC	1.6	74	09.95-		1	6	320	OZA401-E6	1882	1951
Vectra 1.8i	A	C18NZ OHC	1.8	66	03.90-08.95		1	6	320	OZA401-E6	1882	1951
Vectra 1.8i 16V	A	X18XE1	1.8	85	09.95-12.95		4	53	828	OTA7H-3C1	1954	---
Vectra 1.8i 16V	B	X18XE1	1.8	85	01.96-09.00		4	53	708	OTA7L-3C3	0442	---
Vectra 1.8i 16V	B	X18XE	1.8	85	10.95-09.00		4	53	770	OTA7N-5A2	1938	---
Vectra 1.8i 16V	B	Z18XE	1.8	92	01.00-		4	74	741	OZA334-SZ1	0485	1952
Vectra 1.8i 16V	B	Z18XE	1.8	92	01.00-		4	74	571	OZA334-SZ2	0496	1952
Vectra 1.8i 16V	B	Z18XE	1.8	92	01.00-		4	74	401	OZA334-SZ3	0407	1952
Vectra 2.0i 4x4	A	C20NE	2.0	85	01.89-08.95		3	14	885	OZA446-E6	1861	0412
Vectra 2.0i 4x4	A	20NE	2.0	85	01.89-10.90		3	14	885	OZA446-E6	1861	0412
Vectra 2.0i	A	C20NE	2.0	85	09.88-08.95		3	14	885	OZA446-E6	1861	0412
Vectra 2.0i	A	20NE	2.0	85	09.88-10.90		3	14	885	OZA446-E6	1861	0412
Vectra 2.0i 16V	A	X20XEV	2.0	100	03.93-12.95		4	53	828	OTA7H-3C1	1954	---
Vectra 2.0i 16V	B	X20XEV	2.0	100	01.96-02.99		4	53	708	OTA7L-3C3	0442	---
Vectra 2.0i 16V	B	X20XEV	2.0	100	03.99-		4	53	620	OTA7N-5A1	1920	---
Vectra 2.0i 16V 4x4	A	C20XE	2.0	110	02.90-08.92		3	14	885	OZA446-E6	1861	0412
Vectra 2.0i 16V 4x4	A	20XEJ	2.0	110	09.89-10.90		3	14	885	OZA446-E6	1861	0412
Vectra 2.0i 16V	A	20XEJ	2.0	110	09.89-06.94		3	14	885	OZA446-E6	1861	0412
Vectra 2.0i 16V	A	C20XE	2.0	110	02.90-08.95		3	14	885	OZA446-E6	1861	0412
Vectra 2.0i 16V Turbo	C	Z20NET	2.0	129	10.03-		4	87	1465	OZA531-GM16	1891	1952
Vectra 2.0i 16V Turbo	C	Z20NET	2.0	129	03.03-		4	87	1465	OZA531-GM16	1891	1952
Vectra 2.0i 16V Turbo	C	Z20NET	2.0	129	03.03-		4	87	1465	OZA531-GM16	1891	1952
Vectra 2.0i 16V Turbo	C	Z20NET	2.0	129	01.03-		4	49	355	OZA575-GM2	1896	1952
Vectra 2.2i 16V	C	Z22SE	2.2	108	04.02-07.03		4	74	1465	OZA531-GM22	1892	1952
Vectra 2.2i 16V	C	Z22SE	2.2	108	08.03-		4	74	1465	OZA531-GM22	1892	1952
Vectra 2.2i 16V	C	Z22SE	2.2	108	04.02-		4	86	312	OZA583-GM1	1753	1952
Vectra 2.5i V6	B	X25XE DOHC	2.5	125	09.95-	;	3	14	422	OZA446-E40	0193	0412
Vectra 2.5i V6	B	X25XE	2.5	125	10.95-09.00		3	14	885	OZA446-E6	1861	0412
Vectra 2.5i V6 Caravan	B	X25XE	2.5	125	11.96-09.00		3	14	885	OZA446-E6	1861	0412
Zafira 1.6i 16V		X16XEL	1.6	74	03.99-		4	42	320	OZA448-E49	0404	1952
Zafira 1.8i 16V		X18XE1	1.8	85	03.99-09.00		4	53	770	OTA7N-5A2	1938	---
Zafira 1.8i 16V		Z18XE	1.8	92	10.00-		4	74	741	OZA334-SZ1	0485	1952

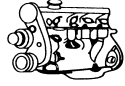

ℓ kW



① ② ③

ORDER
No. No.
STOCK
No. No.
SINCE
A. L. No.**OPEL**

Zafira 1.8i 16V	Z18XE	1.8	92	10.00-		4	74	571	OZA334-SZ2	0496	1952
Zafira 1.8i 16V	Z18XE	1.8	92	10.00-		4	74	401	OZA334-SZ3	0407	1952
Zafira 2.2i 16V	Z22SE	2.2	108	05.99-12.00		4	86	660	OZA531-GM1	1862	1952
Zafira 2.2i 16V	Z22SE	2.2	108	01.01-		4	86	607	OZA531-GM6	1869	1952
Zafira 2.2i 16V	Z22SE	2.2	108	05.01-	/	4	74	1245	OZA531-GM2	1863	1952
Zafira 2.2i 16V	Z22SE	2.2	108	05.01-	/	4	74	1115	OZA531-GM3	1864	1952

PEUGEOT

106 1.0i	TU9M <CDY>	1.0	33	05.96-		4	49	380	OZA448-E57	0492	1952
106 1.0i	TU9M <CDY>	1.0	33	07.92-04.96		4	49	380	OZA448-E57	0492	1952
106 1.0i	TU9M	1.0	33	07.92-06.95		4	58	450	OZA527-E12	0220	1919
106 1.0i	TU9M	1.0	33	07.95-		4	49	375	OZA527-E15	0298	1919
106 1.0i	TU9M <CDY>	1.0	33	07.92-04.96		4	73	370	OZA527-E29	0488	1919
106 1.0i	TU9M <CDZ>	1.0	37	07.92-04.96		4	49	380	OZA448-E57	0492	1952
106 1.0i	TU9M <CDZ>	1.0	37	05.96-		4	49	380	OZA448-E57	0492	1952
106 1.0i	TU9M	1.0	37	07.92-06.95		4	58	450	OZA527-E12	0220	1919
106 1.0i	TU9M	1.0	37	07.95-		4	49	375	OZA527-E15	0298	1919
106 1.0i	TU9M <CDZ>	1.0	37	07.92-04.96		4	73	370	OZA527-E29	0488	1919
106 1.1i	TU1M+ <HDY>	1.1	40-44	05.96-		4	49	380	OZA448-E57	0492	1952
106 1.1i	TU1M <HDY>	1.1	40-44	08.92-04.96	ECE R15-04	4	49	380	OZA448-E57	0492	1952
106 1.1i	TU1M+	1.1	40-44	08.92-06.95		4	58	450	OZA527-E12	0220	1919
106 1.1i	TU1M+	1.1	40-44	07.95-		4	49	375	OZA527-E15	0298	1919
106 1.1i	TU1M	1.1	40-44	05.96-		4	49	375	OZA527-E15	0298	1919
106 1.1i	TU1M <HDY>	1.1	40-44	08.92-04.96	ECE R15-04	4	73	370	OZA527-E29	0488	1919
106 1.1i	TU1M+ <HDZ>	1.1	44	05.96-		4	49	380	OZA448-E57	0492	1952
106 1.1i	TU1M	1.1	44	09.91-12.93		4	58	450	OZA527-E12	0220	1919
106 1.3i	TU2J2 <MFZ>	1.3	72-77	10.93-04.96	ECE R15-04	4	49	380	OZA448-E57	0492	1952
106 1.3i	TU2J2	1.3	72-74	10.93-06.95		4	58	450	OZA527-E12	0220	1919
106 1.3i	TU2J2	1.3	72-74	07.95-04.96		4	49	375	OZA527-E15	0298	1919
106 1.3i	TU2J2 <MFZ>	1.3	72-74	10.93-04.96	ECE R15-04	4	73	370	OZA527-E29	0488	1919
106 1.4i	TU3JP+ <KFX>	1.4	55	01.00-	/ Euro 2000	4	82	536	OZA341-PG5	1813	1952
106 1.4i	TU3JP+ <KFX>	1.4	55	01.00-	/ Euro 2000	4	83	536	OZA495-PG2	1852	1952
106 1.4i	TU3FMC <KDX>	1.4	55	12.92-04.96		4	49	380	OZA448-E57	0492	1952
106 1.4i	TU3MC <KDX>	1.4	55	04.93-04.96		4	49	380	OZA448-E57	0492	1952
106 1.4i	TU3JP <KFX>	1.4	55	05.96-		4	49	380	OZA448-E57	0492	1952
106 1.4i	TU3M	1.4	55	09.91-02.94		4	58	450	OZA527-E12	0220	1919
106 1.4i	TU3MC	1.4	55	04.93-06.95		4	58	450	OZA527-E12	0220	1919
106 1.4i	TU3FMC	1.4	55	12.92-06.95		4	58	450	OZA527-E12	0220	1919
106 1.4i	TU3MC	1.4	55	07.95-04.96		4	49	375	OZA527-E15	0298	1919
106 1.4i	TU3FMC	1.4	55	07.95-04.96		4	49	375	OZA527-E15	0298	1919
106 1.4i	TU3JP	1.4	55	05.96-		4	49	375	OZA527-E15	0298	1919
106 1.4i	TU3FMC <KDX>	1.4	55	12.93-04.96		4	73	370	OZA527-E29	0488	1919
106 1.4i	TU3MC <KDX>	1.4	55	04.93-04.96		4	73	370	OZA527-E29	0488	1919
106 1.4i	TU3FJ <KFZ>	1.4	69	09.91-04.96		4	49	380	OZA448-E57	0492	1952
106 1.4i	TU3FJ	1.4	69	09.91-06.95		4	58	450	OZA527-E12	0220	1919
106 1.4i	TU3FJ	1.4	69	07.95-04.96		4	49	375	OZA527-E15	0298	1919
106 1.4i	TU3FJ <KFZ>	1.4	69	09.91-04.96		4	73	370	OZA527-E29	0488	1919
106 1.4i	TU3FJ <K6B>	1.4	72	09.91-04.96	ECE R15-04	4	49	380	OZA448-E57	0492	1952
106 1.4i	TU3FJ	1.4	72	09.91-06.95		4	58	450	OZA527-E12	0220	1919



① ② ③

ORDER No. No.
STOCK
NUMBER
A.L.No.

PEUGEOT

106 1.4i	TU3FJ	1.4	72	07.95-04.96		4	49	375	OZA527-E15	0298	1919
106 1.4i	TU3FJ <K6B>	1.4	72	09.91-04.96	ECE R15-04	4	73	370	OZA527-E29	0488	1919
106 1.6i	TU5JP	1.6	65-66	06.93-06.95		4	58	450	OZA527-E12	0220	1919
106 1.6i	TU5JP	1.6	65-66	05.96-		4	49	375	OZA527-E15	0298	1919
106 1.6i	TU5JP	1.6	65-66	07.95-04.96		4	49	375	OZA527-E15	0298	1919
106 1.6i	ZU5JP <NFZ>	1.6	66	06.93-04.96		4	49	380	OZA448-E57	0492	1952
106 1.6i	TU5JP <NFZ>	1.6	66	05.96-		4	49	380	OZA448-E57	0492	1952
106 1.6i	TU5JP <NFZ>	1.6	66	06.93-04.96		4	73	370	OZA527-E29	0488	1919
106 1.6i	TU5J2 <NFY>	1.6	74-77	05.96-		4	49	380	OZA448-E57	0492	1952
106 1.6i	TU5J2 <NFW>	1.6	74-77	05.96-		4	49	380	OZA448-E57	0492	1952
106 1.6i	TU5J2	1.6	74-77	05.96-		4	49	375	OZA527-E15	0298	1919
106 1.6i	TU5J2	1.6	76-77	06.93-06.95		4	58	450	OZA527-E12	0220	1919
106 1.6i	TU5J2	1.6	76-77	07.95-04.96		4	49	375	OZA527-E15	0298	1919
106 1.6i	TU5J2 <NFY>	1.6	77	06.93-04.96	ECE R15-04	4	49	380	OZA448-E57	0492	1952
106 1.6i	TU5J2 <NFY>	1.6	77	06.93-04.96	ECE R15-04	4	73	370	OZA527-E29	0488	1919
106 1.6i	TU5J4	1.6	87-88	05.96-		4	49	630	OZA527-E16	0434	1919
106 1.6 16V S16, GTi	TU5JP L4 <NFX>	1.6	88	01.00-	/ Euro 2000	4	82	536	OZA341-PG5	1813	1952
106 1.6 16V S16, GTi	TU5JP L4 <NFX>	1.6	88	01.00-	/ Euro 2000	4	82	536	OZA341-PG5	1813	1952
106 1.6 16V S16, GTI	TU5J4 <NFX>	1.6	88	06.96-01.00	Euro 96	4	49	536	OZA334-PG1	1790	1952
					Engine No. -> 0365						
106 1.6 16V S16, GTI	TU5J4 <NFX>	1.6	88	01.00-	Euro 96 / D3	4	49	536	OZA334-PG1	1790	1952
					Engine No. -> 0365						
205 1.0i	TU9M	1.0	33-37	07.92-		4	37	510	OZA527-E2	0265	1919
205 1.1 CJ	TU1M <HDZ>	1.1	44	10.89-12.94		4	37	510	OZA527-E2	0265	1919
205 1.1	TU1M <HDZ>	1.1	44	07.89-		4	37	510	OZA527-E2	0265	1919
205 1.1	TU1M <HDY>	1.1	44	07.89-		4	37	510	OZA527-E2	0265	1919
205 1.4	TU3CP	1.4	41	10.87-10.90		3	45	510	OZA446-E48	0280	0412
205 1.4	XY7CP	1.4	41	02.83-10.87		3	45	510	OZA446-E48	0280	0412
205 1.4	TU3CP <KAY>	1.4	44	01.89-10.90		3	45	510	OZA446-E48	0280	0412
205 1.4i	TU3MC	1.4	55	09.92-		4	37	510	OZA527-E2	0265	1919
205 1.4i	TU3FM <KDY>	1.4	55	06.91-12.94		4	37	510	OZA527-E2	0265	1919
205 1.4i	TU3M <KDY>	1.4	55-58	07.88-		4	37	510	OZA527-E2	0265	1919
205 1.4i	TU3M <KDZ>	1.4	55-58	07.88-10.90		4	37	510	OZA527-E2	0265	1919
205 1.6	XU5CP	1.6	53-55	02.83-10.87		3	45	510	OZA446-E48	0280	0412
205 1.6i	XU5M <BDY>	1.6	65	05.90-		4	37	510	OZA527-E2	0265	1919
205 1.9	XU9J1	1.9	75	10.86-10.87		3	45	510	OZA446-E48	0280	0412
205 1.9 GTI	XU92C <D2A>	1.9	75	10.87-05.89		3	45	510	OZA446-E48	0280	0412
205 1.9 CTI Cabrio	XU9J1 <DFZ>	1.9	75	10.87-10.94		3	45	510	OZA446-E48	0280	0412
205 1.9	XU9JAZ <DFY>	1.9	88	07.88-		4	37	510	OZA527-E2	0265	1919
205 1.9	XU9JAZ <DKZ>	1.9	88	07.88-		4	37	510	OZA527-E2	0265	1919
206 1.1	TU1JP+ <HFZ>	1.1	44	01.00-	/ Euro 2000	4	82	536	OZA341-PG5	1813	1952
206 1.1	TU1JP+ <HFY>	1.1	44	01.00-	/ Euro 2000	4	82	536	OZA341-PG5	1813	1952
206 1.1	TU1JP+ <HFZ>	1.1	44	01.00-	/ Euro 2000	4	82	536	OZA341-PG5	1813	1952
206 1.1	TU1JP+ <HFY>	1.1	44	01.00-	/ Euro 2000	4	82	536	OZA341-PG5	1813	1952
206 1.4i	TU3JP <K6C>	1.4	55	06.98-		4	73	370	OZA527-E29	0488	1919
206 1.4i	TU3JP+ <KFX>	1.4	55	09.98-	/ Euro 2000	4	82	536	OZA341-PG5	1813	1952
206 1.4i	TU3JP+ <KFX>	1.4	55	09.98-	/ Euro 2000	4	83	536	OZA495-PG2	1852	1952
206 1.6i 16V	TU5JP L4 <NFU>	1.6	81	03.01-	/ Euro 2000	4	82	536	OZA341-PG5	1813	1952
206 1.6i 16V	TU5JP L4 <NFU>	1.6	81	03.01-	/ Euro 2000	4	82	536	OZA341-PG5	1813	1952
305 1.6	XU5CP	1.6	54	10.82-07.90		3	45	510	OZA446-E48	0280	0412
305 1.6 Break	XU5CP	1.6	54	11.86-12.88		3	45	510	OZA446-E48	0280	0412
305 1.9	XU9J1 <DFZ>	1.9	72	11.86-12.88		3	45	510	OZA446-E48	0280	0412

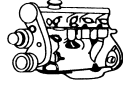

ℓ kW



① ② ③

ORDER
No. No.
STOCK
No. No.
SPECIALS
L. No.**PEUGEOT**

305 1.9	XU9J1 <DFZ>	1.9	72	10.82-07.90		3	45	510	OZA446-E48	0280	0412
306 1.1i	TU1M <HDY>	1.1	40	01.93-12.95		4	49	380	OZA448-E57	0492	1952
306 1.1i	TU1M+ <HDY>	1.1	40	01.96-04.97		4	49	380	OZA448-E57	0492	1952
306 1.1i	TU1M	1.1	40	01.93-02.95		4	58	450	OZA527-E12	0220	1919
306 1.1i	TU1M	1.1	40	03.95-12.95		4	49	375	OZA527-E15	0298	1919
306 1.1i	TU1M+	1.1	40	01.96-04.97		4	49	375	OZA527-E15	0298	1919
306 1.1	TU1M	1.1	44	01.93-02.95		4	58	450	OZA527-E12	0220	1919
306 1.1	TU1M	1.1	44	03.95-12.95		4	49	375	OZA527-E15	0298	1919
306 1.1	TU1M+	1.1	44	01.96-04.97		4	49	375	OZA527-E15	0298	1919
306 1.1i	TU1M+ <HDZ>	1.1	44	01.96-04.97		4	49	380	OZA448-E57	0492	1952
306 1.1i	TU1M <HDZ>	1.1	44	01.93-12.95		4	49	380	OZA448-E57	0492	1952
306 1.4i	TU3MC <KDY>	1.4	55	01.93-04.97		4	49	380	OZA448-E57	0492	1952
306 1.4i	TU3JP <KFX>	1.4	55	09.96-04.97		4	49	380	OZA448-E57	0492	1952
306 1.4i	TU3JP <KFX>	1.4	55	05.97-		4	49	380	OZA448-E57	0492	1952
306 1.4i	TU3MC	1.4	55	01.93-02.95		4	58	450	OZA527-E12	0220	1919
306 1.4i	TU3JP	1.4	55	09.96-04.97		4	49	375	OZA527-E15	0298	1919
306 1.4i	TU3MC	1.4	55	03.95-04.97		4	49	375	OZA527-E15	0298	1919
306 1.4i	TU3JP+ <KFX>	1.4	55	01.00-		4	82	536	OZA341-PG5	1813	1952
306 1.4i	TU3JP+ <KFX>	1.4	55	01.00-		4	83	536	OZA495-PG2	1852	1952
306 1.6i	TU5JP	1.6	65-66	01.93-02.95		4	58	450	OZA527-E12	0220	1919
306 1.6i	TU5JP	1.6	65-66	03.95-04.97		4	49	375	OZA527-E15	0298	1919
306 1.6i	TU5JP <NFZ>	1.6	66	05.97-		4	49	380	OZA448-E57	0492	1952
306 1.6i	TU5JP <NFZ>	1.6	66	01.93-04.97		4	49	380	OZA448-E57	0492	1952
306 1.6i Break	TU5JP <NFZ>	1.6	66	05.97-10.00		4	49	380	OZA448-E57	0492	1952
306 1.8i	XU7JP	1.8	74-76	03.95-04.97		4	49	630	OZA527-E16	0434	1919
306 1.8i	XU7JP	1.8	74-76	01.93-02.95		4	58	1470	OZA527-E3	0201	1919
306 2.0i	XU10J2	2.0	89-90	03.95-04.97		4	49	630	OZA527-E16	0434	1919
306 2.0i	XU10J2	2.0	89-90	08.93-02.95		4	58	1470	OZA527-E3	0201	1919
306 2.0i 16V	XU10J4	2.0	110-114	03.95-04.97		4	49	630	OZA527-E16	0434	1919
306 2.0i 16V	XU10J4	2.0	110-114	08.93-02.95		4	58	1470	OZA527-E3	0201	1919
306 2.0i 16V	XU10J4RS8	2.0	120	07.96-04.97		4	49	1220	OZA527-E17	0445	1919
307 1.4i	TU3JP+ <KFX>	1.4	55	04.01-		4	82	536	OZA341-PG5	1813	1952
307 1.4i	TU3JP+ <KFX>	1.4	55	04.01-		4	83	536	OZA495-PG2	1852	1952
309 1.1i	TU1MZ <HOZ>	1.1	40-44	10.90-12.93		4	37	510	OZA527-E2	0265	1919
309 1.1i	TU1MZ <HDY>	1.1	40-44	10.90-12.93		4	37	510	OZA527-E2	0265	1919
309 1.4	TU3M <KDY>	1.4	55	03.89-07.89		4	37	510	OZA527-E2	0265	1919
309 1.4	TU3M <KDZ>	1.4	55	03.89-07.89		4	37	510	OZA527-E2	0265	1919
309 1.4i	TU3FM <KDY>	1.4	55-58	06.91-12.93		4	37	510	OZA527-E2	0265	1919
309 1.4i	TU3M <KDZ<	1.4	58	10.88-10.90		4	37	510	OZA527-E2	0265	1919
309 1.6	XU5CP	1.6	54	06.86-06.88		3	45	510	OZA446-E48	0280	0412
309 1.6i	XU5M <BDZ>	1.6	65	07.89-03.91		4	37	510	OZA527-E2	0265	1919
309 1.6i	XU5M <BDY>	1.6	65	01.91-12.93		4	37	510	OZA527-E2	0265	1919
309 1.9	XU9J1 <DFZ>	1.9	72	03.86-12.93		3	45	510	OZA446-E48	0280	0412
309 1.9i	XU9M <DDZ>	1.9	80	07.88-12.93		4	37	510	OZA527-E2	0265	1919
309 1.9i GTI	XU9JAZ <DKZ>	1.9	88	07.88-07.89		4	37	510	OZA527-E2	0265	1919
309 1.9i	XU9JAZ <DKZ>	1.9	88-90	07.88-12.93		4	37	510	OZA527-E2	0265	1919
309 1.9i	XU9JAZ <DFY>	1.9	88-90	07.88-12.93		4	37	510	OZA527-E2	0265	1919
309 1.9i 16V	XU9J4/Z	1.9	108	08.90-12.93		4	37	510	OZA527-E2	0265	1919
405 1.4i	TU3MC <KDX>	1.4	55	06.92-04.97		4	58	1470	OZA527-E3	0201	1919
405 1.6i	XU5JP <BFZ>	1.6	65	07.95-04.97		4	49	1220	OZA527-E17	0445	1919
405 1.6i	XU5M <BDY<	1.6	65	07.95-04.97		4	49	1220	OZA527-E17	0445	1919
405 1.6i	XU5M <BDY>	1.6	65	09.90-12.92		4	37	1210	OZA527-E22	0274	1919

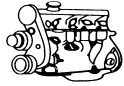

e kW



① ② ③

ORDER
STOCK
 No. No. L.No.
PEUGEOT

405 1.6i	XU5M <BDZ>	1.6	65	07.89-09.90		4	37	1210	OZA527-E22	0274	1919
405 1.6i	XU5M <BDY>	1.6	65	06.92-06.95		4	58	1470	OZA527-E3	0201	1919
405 1.6i	XU5JP <BFZ>	1.6	65	09.94-06.95		4	58	1470	OZA527-E3	0201	1919
405 1.8i	XU7JP <L6A>	1.8	74	06.92-04.97		4	49	380	OZA448-E57	0492	1952
405 1.8i	XU7JP <LFZ>	1.8	74	06.92-04.97		4	49	380	OZA448-E57	0492	1952
405 1.8i	XU7JP	1.8	74	07.95-04.97		4	49	1220	OZA527-E17	0445	1919
405 1.8i	XU7JP	1.8	74	06.92-06.95		4	58	1470	OZA527-E3	0201	1919
405 1.9	XU9J1 <DFZ>	1.9	77	07.87-12.92		3	45	510	OZA446-E48	0280	0412
405 1.9 Break	XU9J1 <DFZ>	1.9	77	10.88-01.89		3	45	510	OZA446-E48	0280	0412
405 1.9i	XU9M <DDZ>	1.9	80	07.88-01.89		4	37	510	OZA527-E2	0265	1919
405 1.9i	XU9M <DDZ>	1.9	80	07.88-12.92		4	37	1210	OZA527-E22	0274	1919
405 1.9i	XU9J2 <DFV>	1.9	82	07.87-01.89		4	37	510	OZA527-E2	0265	1919
405 1.9i	XU9J2 <DDZ>	1.9	82	01.89-12.92		4	37	1210	OZA527-E22	0274	1919
405 1.9i	XU9JAZ <DFY>	1.9	88	07.88-01.89		4	37	510	OZA527-E2	0265	1919
405 1.9i	XU9JAZ <DKZ>	1.9	88	07.88-01.89		4	37	510	OZA527-E2	0265	1919
405 1.9i	XU9JAZ <DFY>	1.9	88	01.89-12.92		4	37	1210	OZA527-E22	0274	1919
405 1.9i	XU9JAZ <DKZ>	1.9	88	01.89-12.92		4	37	1210	OZA527-E22	0274	1919
405 1.9i	XU9J2 <D6D>	1.9	89	07.95-04.97		4	49	1220	OZA527-E17	0445	1919
405 1.9i	XU9J2 <D6D>	1.9	89	06.92-06.95		4	58	1470	OZA527-E3	0201	1919
405 1.9i 16V	XU9J4Z <DFW>	1.9	108-111	04.88-01.89		4	37	510	OZA527-E2	0265	1919
405 1.9i 16V	XU9J4Z <DFW>	1.9	108-111	01.89-12.92		4	37	1210	OZA527-E22	0274	1919
405 2.0i	XU10J2 <RFX>	2.0	89	07.95-04.97		4	49	1220	OZA527-E17	0445	1919
405 2.0i	XU10J2 <R6D>	2.0	89	07.95-04.97		4	49	1220	OZA527-E17	0445	1919
405 2.0i	XU10J2 <RFX>	2.0	89	06.92-06.95		4	58	1470	OZA527-E3	0201	1919
405 2.0i	XU10J2 <R6D>	2.0	89	06.92-06.95		4	58	1470	OZA527-E3	0201	1919
405 2.0i Mi16	XU10J4 <RFT>	2.0	110-118	07.95-06.95		4	49	1220	OZA527-E17	0445	1919
405 2.0i Mi16	XU10J4 <RFY>	2.0	110-118	07.95-04.97		4	49	1220	OZA527-E17	0445	1919
405 2.0i Mi16	XU10J4 <RFT>	2.0	110-118	01.93-06.95		4	58	1470	OZA527-E3	0201	1919
405 2.0i Mi16	XU10J4 <RFY>	2.0	110-118	01.93-04.97		4	58	1470	OZA527-E3	0201	1919
405 2.0i T16	XU10J4TE <RGZ>	2.0	144-159	07.95-04.97		4	49	1220	OZA527-E17	0445	1919
405 2.0i T16	XU10J4TE <RGZ>	2.0	144-159	09.92-06.95		4	58	1470	OZA527-E3	0201	1919
405 2.0i T16 4x4	XU10J4TE <RGZ>	2.0	144-159	09.92-04.97		4	49	380	OZA448-E57	0492	1952
406 1.6i	XU5JP <BFZ>	1.6	65	04.99-		4	49	380	OZA448-E57	0492	1952
406 1.6i	XU5JP <BFZ>	1.6	65	10.95-03.99		4	49	380	OZA448-E57	0492	1952
406 1.6i	XU5JP	1.6	65	04.96-	Org.N. 7084->	4	49	375	OZA527-E15	0298	1919
406 1.6i	XU5JP	1.6	65	10.95-03.96	Org.N. ->7083	4	49	630	OZA527-E16	0434	1919
406 1.8i 16V Break	XU7JP4	1.8	81-82	10.96-12.96	Org.N. 7084-> 7329	4	49	375	OZA527-E15	0298	1919
406 1.8i 16V	XU7JP4	1.8	81-82	04.96-12.96	Org.N. 7084->7329	4	49	375	OZA527-E15	0298	1919
406 1.8i 16V	XU7JP4	1.8	81-82	10.95-03.96	Org.N. ->7083	4	49	630	OZA527-E16	0434	1919
406 1.8i 16V	XU7JP4 <LFY>	1.8	82	10.95-		4	49	380	OZA448-E57	0492	1952
406 2.0i Turbo Break	XU10J2TE	2.0	108-110	10.96-		4	49	630	OZA527-E16	0434	1919
406 2.0i Turbo	XU10J2TE	2.0	108-110	04.96-		4	49	630	OZA527-E16	0434	1919
406 Phase 2 1.8i 16V	EW7J4 <6FZ>	1.8	85	09.00-	/ Euro 2000	4	82	1236	OZA341-PG6	1814	1952
406 Phase 2 1.8i 16V	EW7J4 <6FZ>	1.8	85	09.00-	/ Euro 2000	4	83	536	OZA495-PG2	1852	1952
406 Phase 2 2.0 Hpi 16V	EW10D <RLZ>	2.0	105	04.01-		5	93	375	LZA06-U1	1840	- - -
406 Phase 2 2.0 Hpi 16V	EW10D <RLZ>	2.0	105	04.01-06.01	/ Euro 2000	4	82	1236	OZA538-PG1	1818	1952
406 Phase 2 2.0 Hpi 16V	EW10D <RLZ>	2.0	105	06.01-	/ Euro 2000	4	82	1836	OZA538-PG2	1819	1952
505 2.0i	XN6	2.0	71	05.85-06.86		3	19	490	OZA446-E11	1898	0412
505 2.0	XN6	2.0	71	01.80-06.87		3	45	510	OZA446-E48	0280	0412
505 2.2	ZDJL <851X>	2.2	84	03.86-12.93		3	45	510	OZA446-E48	0280	0412



l kW



① ② ③

ORDER
STOCK
 No. No. L No.
PEUGEOT

505 2.2i Turbo	N9T	2.2	105-106	03.84-06.86		3	19	490	OZA446-E11	1898	0412
505 2.2 Turbo	N9T	2.2	105-116	03.84-10.88		3	45	510	OZA446-E48	0280	0412
505 2.2 Turbo Injektion	N9TEA <176W>	2.2	128	06.87-12.88		3	45	510	OZA446-E48	0280	0412
505 2.8i V6	ZN3J <154X>	2.8	105	06.86-12.93		3	45	510	OZA446-E48	0280	0412
605 2.0	XU10M <LRDZY>	2.0	79	03.91-06.94		4	58	1470	OZA527-E3	0201	1919
605 2.0i	XU10J2 <RFZ>	2.0	89-90	03.91-06.94		4	58	1470	OZA527-E3	0201	1919
605 2.0i Turbo	XU10J2TE <RGY>	2.0	104	07.92-06.94		4	58	1470	OZA527-E3	0201	1919
605 2.0i Turbo	XU10J2TE <RGX>	2.0	104-110	07.94-05.99		4	49	1480	OZA448-E56	0481	1952
806 1.8i	XU7JP <LFW>	1.8	73	06.96-		4	49	1480	OZA448-E56	0481	1952
806 2.0i	XU10J2 <RFU>	2.0	89	06.94-		4	49	1480	OZA448-E56	0481	1952
806 2.0i 16V	XU10J4R <RFV>	2.0	97-99	05.98-		4	49	1480	OZA448-E56	0481	1952
806 2.0i Turbo	XU10J2TE <RGX>	2.0	108	06.94-		4	49	1480	OZA448-E56	0481	1952
Boxer 2.0i	XU10J2 <RFW>	2.0	80	02.94-		4	49	1480	OZA448-E56	0481	1952
Boxer 2.0i	XU10J2	2.0	80	02.94-12.95		4	58	1470	OZA527-E3	0201	1919
Expert 1.6i	222 A2	1.6	58	09.95-		4	49	1480	OZA448-E56	0481	1952
J 5 J 5	XN1TACP	2.0	62	07.87-12.93		3	45	510	OZA446-E48	0280	0412
Partner 1.1i	TU1M+ <HDY>	1.1	44	07.96-		4	49	380	OZA448-E57	0492	1952
Partner 1.1i	TU1M+ <HDZ>	1.1	44	07.96-		4	49	380	OZA448-E57	0492	1952
Partner 1.1i	TU1M+	1.1	44	07.96-		4	49	375	OZA527-E15	0298	1919
Partner 1.4i	TU3JP <KFX>	1.4	55	07.96-		4	49	380	OZA448-E57	0492	1952
Partner 1.4i	TU3JP	1.4	55	07.96-		4	49	375	OZA527-E15	0298	1919
Partner Combi 1.4i	TU3JP+ <KFX>	1.4	55	01.00-		4	82	536	OZA341-PG5	1813	1952
Partner Combi 1.4i	TU3JP+ <KFX>	1.4	55	01.00-		4	83	536	OZA495-PG2	1852	1952

RENAULT

Alpine 2.5i Turbo	Z7U734	2.5	136	06.87-12.92		3	19	490	OZA446-E11	1898	0412
Alpine A610 3.0i Turbo	Z7X744	3.0	184	03.91-		3	14	375	OZA446-E8	1827	0412
Clio 1.2i	D7F730	1.2	40-43	04.96-04.98		3	13	385	OZA446-E57	0472	0412
Clio 1.2i	E7F706	1.2	40-41	06.90-		3	14	375	OZA446-E8	1827	0412
Clio 1.2i	E7F708	1.2	44	10.93-		3	13	180	OZA55-R3	0134	0412
Clio 1.2i	E7F750	1.2	44	02.94-03.96		3	13	180	OZA55-R3	0134	0412
Clio 1.2i	E7F700	1.2	44	06.90-03.96		3	14	375	OZA446-E8	1827	0412
Clio 1.4i	E7J718/ 719	1.4	55-57	06.90-03.96		3	14	375	OZA446-E8	1827	0412
Clio 1.4i	E7J710/ 711	1.4	58-59	06.90-		3	14	375	OZA446-E8	1827	0412
Clio 1.4i	E7J601	1.4	58-59	06.90-		3	14	375	OZA446-E8	1827	0412
Clio 1.4i	E7J757	1.4	59	09.96-		3	14	288	OZA236-R1	0147	0412
Clio 1.4i	E7J756	1.4	59	03.96-		3	13	180	OZA236-R2	0158	0412
Clio 1.4i	E7J754	1.4	59	05.94-06.96		3	13	180	OZA55-R3	0134	0412
Clio 1.8i	F3P714	1.8	65-70	06.90-03.96		3	14	375	OZA446-E8	1827	0412
Clio 1.8i	F3P710	1.8	65-70	06.90-		3	14	375	OZA446-E8	1827	0412
Clio 1.8i	F3P744/ 745	1.8	66	09.96-		3	14	375	OZA446-E8	1827	0412
Clio 1.8i	F3P754/ 755	1.8	66	09.96-		3	14	375	OZA446-E8	1827	0412
Clio 1.8i	F3P745	1.8	66	09.96-		3	14	375	OZA446-E8	1827	0412
Clio 1.8i	F3P754/ 755	1.8	66	01.94-		3	14	375	OZA446-E8	1827	0412
Clio 1.8i	F3P755	1.8	66	01.94-03.96		3	14	375	OZA446-E8	1827	0412
Clio 1.8i	F3P748	1.8	79-81	09.96-		3	14	375	OZA446-E8	1827	0412
Clio 1.8i	F3P758	1.8	79-81	09.96-		3	14	375	OZA446-E8	1827	0412
Clio 1.8i	F3P758	1.8	80-81	01.94-03.96		3	14	375	OZA446-E8	1827	0412
Clio 1.8i 16V	F7P722	1.8	99-101	03.91-03.96		3	14	375	OZA446-E8	1827	0412

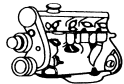

e kW



① ② ③

ORDER
STOCK
 No. No. L.No.
RENAULT

Clio 2.0i Williams	F7R700	2.0	108-110	07.92-03.96		3	14	375	OZA446-E8	1827	0412
Clio II 1.0i	D7D760	1.0	43	03.99-		3	13	385	OZA446-E57	0472	0412
Clio II 1.2i	D7F720	1.2	43	03.98-		3	13	385	OZA446-E57	0472	0412
Clio II 1.2i	D7F722	1.2	43	10.99-		3	13	385	OZA446-E57	0472	0412
Clio II 1.2i 8V	D7F 726	1.2	43	02.99-		4	67	445	OZA277-R2	0468	1952
Clio II 1.2i 8V	D7F 726	1.2	43	02.99-		4	67	445	OZA277-R2	0468	1952
Clio II 1.2i 16V	D4F	1.2	55	10.00-		4	67	445	OZA507-R2	0480	1952
Clio II 1.2i 16V	D4F	1.2	55	10.00-		4	67	445	OZA507-R2	0480	1952
Clio II 1.4	E7J780	1.4	55	04.98-		3	24	257	OZA311-R2	0126	0412
Clio II 1.4	E7J781	1.4	55	04.98-		3	24	257	OZA311-R2	0126	0412
Clio II 1.4i 16V	K4J 712 / 713	1.4	70	10.99-		4	67	380	OZA448-E50	0415	1952
Clio II 1.6	K7M744 / 745	1.6	66	04.98-		3	24	257	OZA311-R2	0126	0412
Clio II 1.6i 16V	K4M 748	1.6	79	06.98-		4	67	380	OZA448-E50	0415	1952
Espace 2.0i	J7R768	2.0	77	01.91-02.93	Fg.Nr. ->T12551,K1100	3	19	490	OZA446-E11	1898	0412
Espace 2.0i	J7R768	2.0	77	03.93-	Fg.Nr. T12552,K1101->	3	14	375	OZA446-E8	1827	0412
Espace 2.0i	F3R 768 / 769	2.0	83.5	10.96-		4	28	255	OZA448-E43	0282	1952
Espace 2.0i	F3R 728 / 729	2.0	83.5	10.96-		4	28	255	OZA448-E43	0282	1952
Espace 2.2i	J7T770	2.2	79-81	07.86-12.90		1	3	472	OZA401-E2	1802	1951
Espace 2.2i Quadra	J7T770	2.2	79-81	01.88-12.90		1	3	472	OZA401-E2	1802	1951
Espace 2.2i	J7T772/ 773	2.2	79-81	01.91-		3	14	375	OZA446-E8	1827	0412
Espace 2.2i	J7T772/ 773	2.2	79-81	05.91-		3	14	375	OZA446-E8	1827	0412
Espace 2.9i	Z7W712/ 713	2.9	110-113	01.91-07.94	Fg.Nr. ->T18370	3	19	490	OZA446-E11	1898	0412
Espace 2.9i	Z7W712/ 713	2.9	110-113	04.94-		3	14	375	OZA446-E8	1827	0412
Espace 3.0	Z7X775	3.0	123	10.96-09.98		4	28	368	OZA83-R3	0178	1952
Espace 4 3.5i V6 24V	V4Y-711	3.5	180	10.02-		4	70	371	OZA544-N8	1804	1952
Espace 4 3.5i V6 24V	V4Y-711	3.5	180	10.02-		4	88	500	OZA544-R1	1857	1952
Express 1.2	C3G710	1.2	40	93-06.95		2	10	370	OZA428-E1	1807	1918
Express 1.2	C3G712	1.2	40	10.96-		3	14	228	OZA55-R4	0145	0412
Express 1.4	E7J770	1.4	55	10.96-		3	14	288	OZA236-R1	0147	0412
Express 1.4	E7J771	1.4	55	11.96-		3	13	180	OZA236-R2	0158	0412
Express 1.4	E7J728	1.4	55	05.94-07.96		3	13	180	OZA55-R3	0134	0412
Express, Extra, Rapi1.4i	C3J762	1.4	44	09.91-05.95		1	3	472	OZA401-E2	1802	1951
Express, Extra, Rapi1.4i	C3J760	1.4	44	06.87-08.91	Fg.Nr. ->U034749	1	3	472	OZA401-E2	1802	1951
Express, Extra, Rapi1.4i	C3J700	1.4	44	03.86-05.87	Fg.Nr. ->U034749	1	3	472	OZA401-E2	1802	1951
Express, Extra, Rapi1.4i	C3J702	1.4	44	06.87-08.91		1	3	472	OZA401-E2	1802	1951
Express, Extra, Rapi1.4i	C3J762	1.4	44	06.95-	Fg.Nr.->U034750	3	14	375	OZA446-E8	1827	0412
Express, Extra, Rapi1.4i	E7J720	1.4	55-59	09.91-		3	14	375	OZA446-E8	1827	0412
Express, Extra, Rapi1.4i	E7J724/ 710	1.4	55-59	09.91-		3	14	375	OZA446-E8	1827	0412
Express, Extra, Rapi1.4i	E7J728/ 754	1.4	55-59	03.94-		3	14	375	OZA446-E8	1827	0412
Express, Extra, Rapi1.4i	E7J773/ 710	1.4	55-59	03.94-		3	14	375	OZA446-E8	1827	0412
Grand Espace 3.5i V6 24V	V4Y-711	3.5	180	10.02-		4	70	371	OZA544-N8	1804	1952
Grand Espace 3.5i V6 24V	V4Y-711	3.5	180	10.02-		4	88	500	OZA544-R1	1857	1952
Kangoo 1.0i	D7D700	1.0	43	09.98-		3	13	385	OZA446-E57	0472	0412
Kangoo 1.2i 8V	D7F726	1.2	43	07.98-		4	67	445	OZA277-R2	0468	1952
Kangoo 1.2i 8V	D7F726	1.2	43	07.98-		4	67	445	OZA277-R2	0468	1952
Kangoo 1.2i	D7F720	1.2	44	03.98-		3	13	385	OZA446-E57	0472	0412
Kangoo 1.2i	D7F726	1.2	44	09.98-		3	13	385	OZA446-E57	0472	0412
Kangoo 1.2i GPL	D7F722	1.2	44	10.97-		3	13	385	OZA446-E57	0472	0412
Kangoo 1.2i 16V	D4F	1.2	55	10.00-		4	67	445	OZA507-R2	0480	1952
Kangoo 1.2i 16V	D4F	1.2	55	10.00-		4	67	445	OZA507-R2	0480	1952

Fg = Chassis No.

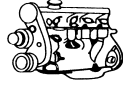

ℓ kW



① ② ③

ORDER
No. No.
STOCK
No. No.
SINCE
1985
L No.**RENAULT**

Kangoo 1.4i	E7J780	1.4	54	10.97-04.98		3	13	255	OZA311-R1	0191	0412
Kangoo 1.4i	E7J780	1.4	54	05.98-		3	24	257	OZA311-R2	0126	0412
Laguna 1.8i	F3P 678	1.8	66	-03.95		3	14	288	OZA55-R1	1878	0412
Laguna 1.8i	F3P 670 / 674	1.8	66-70	09.95-		4	28	255	OZA448-E43	0282	1952
Laguna 1.8i Grandtour, Nevada	F3P 670 / 674	1.8	66-70	09.95-		4	28	255	OZA448-E43	0282	1952
Laguna 1.9i	N7Q700	1.9	103	03.95-		4	28	478	OZA83-R1	0156	1952
Laguna 1.9i	N7Q704	1.9	103	06.95-		4	28	478	OZA83-R1	0156	1952
Laguna 2.0i	F3R 722 / 723	2.0	83	-03.95		3	14	288	OZA55-R1	1878	0412
Laguna 2.0i	F3R 768 / 769	2.0	83-85	09.95-		4	28	255	OZA448-E43	0282	1952
Laguna 2.0i	F3R 728 / 729	2.0	83-85	09.95-		4	28	255	OZA448-E43	0282	1952
Laguna 2.0i Grantour, Nevada	F3R 728 / 729	2.0	83-85	09.95-		4	28	255	OZA448-E43	0282	1952
Laguna 2.0i Grantour, Nevada	F3R 768 / 769	2.0	83-85	09.95-		4	28	255	OZA448-E43	0282	1952
Laguna 3.0i	Z7X765	3.0	125	-11.96		3	14	368	OZA55-R2	0123	0412
Laguna 3.0i	Z7X760	3.0	125	-11.96		3	14	368	OZA55-R2	0123	0412
Laguna 3.0i	Z7X767	3.0	125	10.96-		4	28	368	OZA83-R3	0178	1952
Master T 28-35	J7T782	2.2	67	09.80-		1	3	472	OZA401-E2	1802	1951
Master 2.2 R.E.	J7T788	2.2		07.94-		3	14	368	OZA55-R2	0123	0412
Megane 1.4i	E7J624	1.4	51	02.96-		3	14	288	OZA236-R1	0147	0412
Megane 1.4i	E7J764	1.4	55	04.95-		3	14	288	OZA236-R1	0147	0412
Megane 1.6i	K7M702 / 703 / 720	1.6	66	06.95-		3	14	288	OZA236-R1	0147	0412
Megane 2.0i Cabrio	F3R 791 / 796	2.0	83	09.96-		4	28	255	OZA448-E43	0282	1952
Megane 2.0i Coupe	F3R 750	2.0	83	01.96-		4	28	255	OZA448-E43	0282	1952
Megane 2.0i Classic	F3R 750 / 751 / 752	2.0	83-84	09.96-		4	28	255	OZA448-E43	0282	1952
Megane 2.0i	F3R 750 / 751	2.0	83-84	01.96-		4	28	255	OZA448-E43	0282	1952
Megane 2.0i	F3R 791	2.0	84	03.97-		4	28	255	OZA448-E43	0282	1952
Megane 2.0i	F3R 796 / 797 / 798	2.0	84	01.97-		4	28	255	OZA448-E43	0282	1952
Megane 2.0i Classic	F3R 796 / 797 / 798	2.0	84	09.96-		4	28	255	OZA448-E43	0282	1952
Megane 2.0i 16V Cabrio	F7R 710 / 714	2.0	108	09.96-		4	28	255	OZA448-E43	0282	1952
Megane 2.0i 16V Coupe	F7R 710	2.0	108	01.96-		4	28	255	OZA448-E43	0282	1952
Megane 2.0i 16V	F7R 710 / 714	2.0	108-110	01.96-		4	28	255	OZA448-E43	0282	1952
R 11 1.7i	F3N718	1.7	55	12.88-03.91		3	14	375	OZA446-E8	1827	0412
R 11 1.7	F3N708	1.7	69	12.88-03.91		3	14	375	OZA446-E8	1827	0412
R 19 1.2i	E7F730	1.2	46	05.92-		3	14	375	OZA446-E8	1827	0412
R 19 1.4i	C3J710/ 760	1.4	40-44	08.93-	Fg.Nr. D02451(C532)->	1	3	472	OZA401-E2	1802	1951
R 19 1.4i	C3J710/ 760	1.4	40-44	08.93-	Fg.Nr. D036147 (L532)->	3	14	375	OZA446-E8	1827	0412
R 19 1.4i	E7J745	1.4	55-59	07.92-		3	14	375	OZA446-E8	1827	0412
R 19 1.4i	E7J700	1.4	55-59	05.90-11.93		3	14	375	OZA446-E8	1827	0412
R 19 1.4	E7J742	1.4	55	11.94-11.95		3	13	180	OZA55-R3	0134	0412
R 19 1.7i	F3N740/ 741/ 718	1.7	54	07.92-		1	3	472	OZA401-E2	1802	1951
R 19 1.7i	F3N740/ 741/ 718	1.7	54	07.92-		1	3	472	OZA401-E2	1802	1951
R 19 1.7i	F3N742/ 743	1.7	66-70	09.88-		3	14	375	OZA446-E8	1827	0412
R 19 1.8i	F3P760	1.8	65	10.94-		3	14	375	OZA446-E8	1827	0412
R 19 1.8i	F3P708/ 760	1.8	65	02.93-		3	14	375	OZA446-E8	1827	0412
R 19 1.8i	F3P706/ 707	1.8	65	05.92-		3	14	375	OZA446-E8	1827	0412
R 19 1.8i	F3P704/ 705	1.8	65	05.92-		3	14	375	OZA446-E8	1827	0412
R 19 1.8i	F3P706	1.8	65-66	09.94-		3	14	375	OZA446-E8	1827	0412
R 19 1.8i	F3P682/ 765	1.8	79	09.94-		3	14	375	OZA446-E8	1827	0412

Fg = Chassis No.

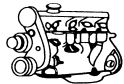

① ② ③

ORDER No. No. STOCK No. No. INVENTORY No. No.

RENAULT

R 19 1.8i	F3P764/ 765	1.8	79	10.94-		3	14	375	OZA446-E8	1827	0412
R 19 1.8i	F3P682/ 700	1.8	79-83	05.92-		3	14	375	OZA446-E8	1827	0412
R 19 1.8i 16V	F7P704	1.8	99-101	06.89-		3	14	375	OZA446-E8	1827	0412
R 21 1.7i	F3N726/ 740/ 718	1.7	54	03.86-12.94	Fg.Nr. +1,H7251,S1723->	1	3	472	OZA401-E2	1802	1951
R 21 1.7i Nevada	F3N726/ 718/ 740	1.7	54	06.86-12.95	Fg.Nr.H00004301->	1	3	472	OZA401-E2	1802	1951
R 21 1.7i HB	F3N726/ 718/ 740	1.7	54	09.89-12.93	Fg.Nr. S00007201->	1	3	472	OZA401-E2	1802	1951
R 21 1.7i Nevada	F3N722/ 723	1.7	66-70	06.86-12.95	Fg.Nr. H00007401->	3	14	375	OZA446-E8	1827	0412
R 21 1.7i HB	F3N722/ 723	1.7	66-70	09.89-12.93		3	14	375	OZA446-E8	1827	0412
R 21 1.7i	F3N722/ 723	1.7	66-70	03.86-12.94	Fg.Nr. H9001,S1241,U1->	3	14	375	OZA446-E8	1827	0412
R 21 2.0i	JR746/ 747	2.0	75	06.90-12.94		3	14	375	OZA446-E8	1827	0412
R 21 2.0i Nevada	J7R746/ 747	2.0	88	06.90-12.95		3	14	375	OZA446-E8	1827	0412
R 21 2.0i HB	J7R746/ 747	2.0	99	06.90-12.93		3	14	375	OZA446-E8	1827	0412
R 21 2.0i HB	J7R740	2.0	100	09.89-12.93		3	14	375	OZA446-E8	1827	0412
R 21 2.0i Turbo	J7R756	2.0	119-121	05.89-03.93		3	14	375	OZA446-E8	1827	0412
R 21 2.2i Nevada	J7T754/ 755	2.2	79-81	02.90-12.95	Fg.Nr. S00009742->	1	3	472	OZA401-E2	1802	1951
R 21 2.2i	J7T754/ 755	2.2	79-81	02.90-12.94	Fg.Nr. S00005773->	1	3	472	OZA401-E2	1802	1951
R 21 2.2i HB	JT754/ 755	2.2	79-81	09.89-12.93	Fg.Nr. S00006710->	1	3	472	OZA401-E2	1802	1951
R 21 2.2i	J7T754/ 755	2.2	79-81	07.86-02.90	Fg.Nr. ->S00005772	3	14	375	OZA446-E8	1827	0412
R 21 2.2i HB	J7T754/ 755	2.2	79-81	09.89-12.93	Fg.Nr. ->S00006709	3	14	375	OZA446-E8	1827	0412
R 21 2.2i Nevada	J7T754/ 755	2.2	79-81	10.86-01.90	Fg.Nr. ->S00009741	3	14	375	OZA446-E8	1827	0412
R 21 2.2i Nevada	J7T756	2.2	79-81	04.93-12.95		3	14	375	OZA446-E8	1827	0412
R 25 2.0i	JR726	2.0	99-100	06.89-12.92		3	14	375	OZA446-E8	1827	0412
R 25 2.2i	J7T732/ 733	2.2	79-81	02.90-12.92		1	3	472	OZA401-E2	1802	1951
R 25 2.5i Turbo	Z7U700	2.5	147-151	05.89-12.92		3	14	375	OZA446-E8	1827	0412
R 25 2.9i	Z7W706/ 707	2.9	110-112	06.87-12.92		3	19	490	OZA446-E11	1898	0412
R 5 1.4i	C3J	1.4	44	07.89-03.95	Fg.Nr.->Y047117	1	3	472	OZA401-E2	1802	1951
R 5 1.7i	F3N702/ 722	1.7	69	10.86-12.96	Fg.Nr. F00004823->	3	19	490	OZA446-E11	1898	0412
R 5 1.7i	F3N702/ 722	1.7	69	10.86-12.96	Fg.Nr. F00004691 -F00004822	3	14	375	OZA446-E8	1827	0412
R 9 1.7i	F3N718	1.7	54	12.88-03.91		3	14	375	OZA446-E8	1827	0412
R 9 1.7i	F3N708/ 722	1.7	69	12.88-03.91		3	14	375	OZA446-E8	1827	0412
Safrane 1.8	N7Q710/ 711	1.8	100	10.96-		4	28	318	OZA83-R2	0167	1952
Safrane 2.0	J7R 732 / 733	2.0	79	-10.96		3	14	288	OZA55-R1	1878	0412
Safrane 2.0	J7R 734 / 735 12V	2.0	97	-10.96		3	14	288	OZA55-R1	1878	0412
Safrane 2.2	J7T 766 / 767	2.2		-10.96		3	14	288	OZA55-R1	1878	0412
Safrane 2.2	J7T 762 / 763	2.2	79	-10.96		3	14	288	OZA55-R1	1878	0412
Safrane 2.2	J7T 760 / 761 12V	2.2	101	-10.96		3	14	288	OZA55-R1	1878	0412
Safrane 3.0	Z7X 722 / 723 / 753	3.0	123	-10.96		3	14	288	OZA55-R1	1878	0412
Safrane 3.0	Z7X755	3.0	125	10.96-		4	28	253	OZA83-R4	0189	1952
Scenic 1.4i	E7J764	1.4	55	04.95-		3	14	288	OZA236-R1	0147	0412
Scenic 1.6i	K7M702 / 703 / 720	1.6	66	06.95-		3	14	288	OZA236-R1	0147	0412
Scenic 2.0i	F3R 750 / 751	2.0	83-84	11.96-		4	28	255	OZA448-E43	0282	1952
Scenic 2.0i	F3R 796 / 797 / 798	2.0	84	11.96-		4	28	255	OZA448-E43	0282	1952
Scenic 2.0i	F3R 791	2.0	84	11.96-		4	28	255	OZA448-E43	0282	1952
Sport Spider 2.0i	F7R 710 / 712 / 720	2.0	108-110	05.96-		4	28	255	OZA448-E43	0282	1952

Fg = Chassis No.

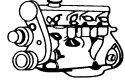

ℓ kW



① ② ③

ORDER
STOCK
 No. No. L No.
RENAULT

Trafic 2.2i	J7T780	2.2	69-71	03.96-		1	3	472	OZA401-E2	1802	1951
Trafic 2.2	J7T 600	2.2	70	07.94-		3	14	288	OZA55-R1	1878	0412
Twingo 1.0i	D7D 740	1.0	43	01.00-		3	13	385	OZA446-E57	0472	0412
Twingo 1.2i	C3G 700	1.2	40	03.93-08.96		2	10	370	OZA428-E1	1807	1918
Twingo 1.2i	C3G 702	1.2	40	03.93-08.97		3	14	228	OZA55-R4	0145	0412
Twingo 1.2i	D7F 700	1.2	40-44	09.96-11.99		3	13	385	OZA446-E57	0472	0412
Twingo 1.2i	D7F 701	1.2	40-44	09.96-11.99		3	13	385	OZA446-E57	0472	0412
Twingo 1.2i	D7F 700	1.2	40-44	12.99-		4	67	380	OZA448-E50	0415	1952
Twingo 1.2i	D7F 701	1.2	40-44	12.99-		4	67	380	OZA448-E50	0415	1952
Twingo 1.2i	D7F 706	1.2	43	09.98-11.99		3	13	385	OZA446-E57	0472	0412
Twingo 1.2i	D7F 706	1.2	43	12.99-		4	67	380	OZA448-E50	0415	1952
Twingo 1.2i 8V	D7F 702	1.2	44	07.98-11.00		4	67	445	OZA277-R2	0468	1952
Twingo 1.2i 8V	D7F 702	1.2	44	07.98-11.00		4	67	445	OZA277-R2	0468	1952
Twingo 1.2i 8V	D7F 703	1.2	44	07.98-11.00		4	67	445	OZA277-R2	0468	1952
Twingo 1.2i 8V	D7F 703	1.2	44	07.98-11.00		4	67	445	OZA277-R2	0468	1952
Twingo 1.2i 16V	D4F 702	1.2	55	10.00-		4	67	445	OZA507-R2	0480	1952
Twingo 1.2i 16V	D4F 702	1.2	55	10.00-		4	67	445	OZA507-R2	0480	1952
Twingo 1.2i 16V	D4F 703	1.2	55	10.00-		4	67	445	OZA507-R2	0480	1952
Twingo 1.2i 16V	D4F 703	1.2	55	10.00-		4	67	445	OZA507-R2	0480	1952
Vel Satis 3.5i V6 24V	V4Y-701	3.5	180	10.02-		4	70	371	OZA544-N8	1804	1952
Vel Satis 3.5i V6 24V	V4Y-701	3.5	180	10.02-		4	88	500	OZA544-R1	1857	1952

ROVER

25 1.4i 16V	K14	1.4	62	02.00-	Fg.Nr. ->YD 471564	4	33	590	OZA527-E9	0498	1919
25 1.4i 16V	K14	1.4	76	02.00-	Fg.Nr. ->YD 471564	4	33	590	OZA527-E9	0498	1919
25 1.6i 16V	K16	1.6	80	02.00-	Fg.Nr. ->YD 471564	4	33	590	OZA527-E9	0498	1919
25 1.8i 16V	K18	1.8	86	02.00-	Fg.Nr. ->YD 471564	4	33	590	OZA527-E9	0498	1919
25 1.8i 16V	K18	1.8	107	02.00-	Fg.Nr. ->YD 471564	4	33	590	OZA527-E9	0498	1919
45 1.4i 16V	K14	1.4	76	02.00-	Fg.Nr. ->YD 471063	4	33	590	OZA527-E9	0498	1919
45 1.6i 16V	K16	1.6	80	02.00-	Fg.Nr. ->YD 471063	4	33	590	OZA527-E9	0498	1919
45 2.0i V6	KV6	2.0	110	02.00-		4	33	545	OZA527-E18	0430	1919
75 1.8i	K4	1.8	88	05.98-		4	75	620	OZA341-RV2	0429	1952
75 2.0i	KV6	2.0	110	05.98-		4	75	620	OZA341-RV2	0429	1952
75 2.0i	KV6	2.0	110	05.98-		4	75	620	OZA341-RV2	0429	1952
75 2.5i	KV6	2.5	130	05.98-		4	75	620	OZA341-RV2	0429	1952
75 2.5i	KV6	2.5	130	05.98-		4	75	620	OZA341-RV2	0429	1952
100 Metro 1.1i	11K2D	1.1	44	09.90-12.97		4	33	390	OZA527-E8	0284	1919
100 Metro 1.4i	K-Serie	1.4	55	09.90-03.98		4	33	390	OZA527-E8	0284	1919
100 Metro 1.4i 16V	14K4D	1.4	66-70	05.90-12.92		4	33	390	OZA527-E8	0284	1919
100 Metro 1.4i 16V	14K4C	1.4	66-70	05.90-12.92		4	33	390	OZA527-E8	0284	1919
100 Metro 1.4i 16V Cabrio	K-Serie	1.4	75	04.97-10.98		4	33	390	OZA527-E8	0284	1919
100 Metro 1.4i 16V GTI	14K4F	1.4	76	05.90-10.95		4	33	390	OZA527-E8	0284	1919
211 1.1i	K-Serie	1.1	44	11.95-03.00	Fg.Nr. ->YD 471564	4	33	590	OZA527-E9	0498	1919
211 1.4i	14K2A	1.4	55	01.93-02.96		4	33	390	OZA527-E8	0284	1919
214 1.4i	14K2F	1.4	55	10.95-03.00	Fg.Nr. ->YD 471564	4	33	590	OZA527-E9	0498	1919
214 1.4i 16V	K16 DOHC	1.4	66	10.89-09.93		4	33	390	OZA527-E8	0284	1919
214 1.4i 16V	K16 DOHC	1.4	76	10.92-02.96		4	33	390	OZA527-E8	0284	1919
214 1.4i 16V	14KAF	1.4	76	10.95-03.00	Fg.Nr. ->YD 471564	4	33	590	OZA527-E9	0498	1919
214 1.4i 16V Cabrio	K16 DOHC	1.4	76	10.92-03.96		4	33	390	OZA527-E8	0284	1919

Fg = Chassis No.

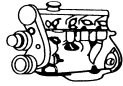

e kW



① ② ③

ORDER
STOCK
 No. No. L.No.
ROVER

216 1.6i 16V	16K4F	1.6	82	10.95-03.00	Fg.Nr. ->YD 471564	4	33	590	OZA527-E9	0498	1919
216 1.6i 16V Cabrio	16K4F	1.6	82	03.96-03.00		4	33	590	OZA527-E9	0498	1919
216 1.6i 16V Coupe	16K4F	1.6	82	03.96-03.00		4	33	590	OZA527-E9	0498	1919
218 1.8i 16V	K-Serie	1.8	88	10.95-03.00	Fg.Nr. ->YD 471564	4	33	590	OZA527-E9	0498	1919
218 1.8i 16V	18K4K	1.8	107	10.95-03.00	Fg.Nr. ->YD 471564	4	33	590	OZA527-E9	0498	1919
218 1.8i 16V Coupe	K-Serie	1.8	107	03.96-03.00		4	33	590	OZA527-E9	0498	1919
220 2.0 Turbo	20T4G	2.0	147	01.93-06.96		4	33	390	OZA527-E8	0284	1919
220 2.0 GTi	T16 DOHC	2.0	100	10.92-06.96		4	33	590	OZA527-E9	0498	1919
220 2.0 GSi	T16 DOHC	2.0	100	10.92-06.96		4	33	590	OZA527-E9	0498	1919
220 2.0 GTi	T16 DOHC	2.0	103	09.91-06.96		4	33	590	OZA527-E9	0498	1919
414 1.4i 16V GSi	K16 DOHC	1.4	70	04.90-10.92		4	33	390	OZA527-E8	0284	1919
414 1.4i 16V GSi	K14K4F	1.4	76	01.93-02.96		4	33	390	OZA527-E8	0284	1919
416 1.6i 16V	K16	1.6	82	05.95-03.00		4	33	590	OZA527-E9	0498	1919
416 1.6i 16V Tourer	D16 B2	1.6	82	02.96-03.00		4	33	590	OZA527-E9	0498	1919
418 1.8i 16V Tourer	WC DOHC	1.8	107	03.96-12.98		4	33	590	OZA527-E9	0498	1919
420 2.0i 16V GTi	20T4H	2.0	100	10.95-03.00		4	33	545	OZA527-E18	0430	1919
420 2.0i 16V GTi	T16 DOHC	2.0	103	02.92-02.96		4	33	590	OZA527-E9	0498	1919
420 2.0i 16V Turbo	20T4G	2.0	147	01.93-02.96		4	33	390	OZA527-E8	0284	1919
618 1.8i	F18A3	1.8	85	03.96-02.99		4	44	410	OZA245-H1	0169	1952
620 2.0i	F20Z2	2.0	85	08.93-06.96		4	44	410	OZA245-H1	0169	1952
620 2.0i	F20Z1	2.0	96	08.93-02.99		4	44	410	OZA245-H1	0169	1952
620 2.0i 16V Turbo	T16 Turbo	2.0	147	04.93-12.98		4	33	390	OZA527-E8	0284	1919
623 2.3i	H23A3	2.3	116	01.96-02.99		4	43	225	OZA245-H2	0180	1952
820 2.0i	20HDM16	2.0	98	10.88-12.91		3	55	521	OTD3G-3A1	0453	- - -
820 2.0i	20T4H	2.0	100	01.92-01.96		4	33	590	OZA527-E9	0498	1919
820 2.0i 16V Turbo	T16	2.0	132-147	01.92-01.99		4	33	390	OZA527-E8	0284	1919
825 2.5 V6	25K4F	2.5	129	04.96-02.99		4	33	540	OZA222-RV1	0136	1952
Mini 1.3	SPI	1.3	39-46	02.91-09.00		4	33	390	OZA527-E8	0284	1919
Mini 1.3 Cooper	SPI	1.3	39-46	02.91-09.00		4	33	390	OZA527-E8	0284	1919

SAAB

900 2.0i	B2011	2.0	81	09.87-08.90		3	19	1215	OZA446-E16	1859	0412
900 2.0i 16V	B2021	2.0	92-93	09.85-08.92		3	19	1215	OZA446-E16	1859	0412
900 2.0i 16V	B2021	2.0	92-98	09.89-08.92		3	19	1215	OZA446-E16	1859	0412
900 2.0i 16V Cabrio	B2021	2.0	92-99	09.89-08.93		3	19	1215	OZA446-E16	1859	0412
900 2.0i Turbo	B201S	2.0	103	09.88-09.90		3	19	1215	OZA446-E16	1859	0412
900 2.0i 16V Turbo	B202L	2.0	118	08.84-08.85		1	3	472	OZA401-E2	1802	1951
900 2.0i 16V Turbo	B202L	2.0	118	09.85-08.89		3	19	1215	OZA446-E16	1859	0412
900 2.1i 16V	B2121	2.1	100-103	09.90-08.93		3	19	1215	OZA446-E16	1859	0412
900 2.1i 16V Cabrio	B2121	2.1	103	09.91-08.93		3	19	1215	OZA446-E16	1859	0412
900 II S 2.0i	B2041	2.0	96	09.94-08.98		3	77	1095	OZA446-E58	0483	0412
900 II S 2.0i Coupe	B2041	2.0	96	09.94-08.98		3	77	1095	OZA446-E58	0483	0412
900 II 2.0i	B2061	2.0	98	09.93-08.98		3	77	1095	OZA446-E58	0483	0412
900 II 2.0i Coupe	B2061	2.0	98	03.94-08.98		3	77	1095	OZA446-E58	0483	0412
900 II 2.0i Cabrio	B2061	2.0	98	09.93-08.98		3	77	1095	OZA446-E58	0483	0412
900 II 2.0i 16V Turbo	B204L	2.0	136	09.93-08.98		3	77	1095	OZA446-E58	0483	0412
900 II 2.0i 16V Turbo Cabrio	B204L	2.0	136	09.93-08.98		3	77	1095	OZA446-E58	0483	0412
900 II 2.0i 16V Turbo Coupe	B204L	2.0	136	03.94-08.98		3	77	1095	OZA446-E58	0483	0412
900 II 2.3i 16V Coupe	B2341	2.3	110	03.94-08.98		3	77	1095	OZA446-E58	0483	0412
900 II 2.3i 16V Cabrio	B2341	2.3	110	09.93-08.98		3	77	1095	OZA446-E58	0483	0412
900 II 2.3i 16V	B2341	2.3	110	09.93-08.98		3	77	1095	OZA446-E58	0483	0412
9000 2.0i 16V	B2021	2.0	90-92	09.86-08.91		3	19	670	OZA446-E1	1833	0412

Fg = Chassis No.

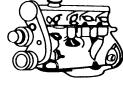

ℓ kW



① ② ③

ORDER
STOCK
 No. No.
SAAB

9000 2.0i 16V	B202I	2.0	90-92	08.86-08.86		3	19	1215	OZA446-E16	1859	0412
9000 2.0i 16V CD	B202I	2.0	92-96	09.89-08.91		3	19	1215	OZA446-E16	1859	0412
9000 2.0i 16V Turbo	B202L	2.0	118	09.84-08.88		3	19	1215	OZA446-E16	1859	0412
9000 2.0i Turbo CD	B202L	2.0	118-120	05.88-08.91		3	19	1215	OZA446-E16	1859	0412
9000 2.0i 16V Turbo	B202L	2.0	118-121	01.90-08.93		3	19	1215	OZA446-E16	1859	0412
9000 2.3i 16V CD	B234L	2.3	107	09.89-08.91		3	19	1215	OZA446-E16	1859	0412
9000 2.3i 16V	B234I	2.3	107-114	09.89-08.91		3	19	1215	OZA446-E16	1859	0412
9000 2.3i 16V CDE Eco-Power	B234E	2.3	125	09.93-12.98		3	77	1095	OZA446-E58	0483	0412
9000 2.3i 16V CS Eco Power	B234E	2.3	125	09.93-12.98		3	77	1095	OZA446-E58	0483	0412
9000 2.3 Turbo CD	B234L	2.3	143	09.91-08.93		3	19	1215	OZA446-E16	1859	0412
9000 2.3 Turbo S CD	B234L	2.3	143	09.90-08.91		3	19	1215	OZA446-E16	1859	0412
9000 2.3i 16V Turbo	B234	2.3	143	09.90-06.91		3	19	1215	OZA446-E16	1859	0412
9000 2.3i 16V CDE Turbo	B234L	2.3	147	09.93-12.98		3	77	1095	OZA446-E58	0483	0412
9000 2.3i 16V Turbo CSE	B234L	2.3	147	09.93-12.98		3	77	1095	OZA446-E58	0483	0412
9000 2.3i 16V Turbo Aero CS	B234R	2.3	165	09.92-12.98		3	77	1095	OZA446-E58	0483	0412
9-3 2.0i 16V	B204I	2.0	96	03.98-		3	77	1095	OZA446-E58	0483	0412
9-3 2.0 16V Turbo Eco-Power	B205L	2.0	110	01.99-		3	77	1095	OZA446-E58	0483	0412
9-3 2.0 16V Turbo	B204L	2.0	113	09.98-		3	77	1095	OZA446-E58	0483	0412
9-3 2.0 16V Turbo	B204E	2.0	113	01.98-		3	77	1095	OZA446-E58	0483	0412
9-3 2.0T Cabrio	YS3F	2.0	129	08.03-		4	49	425	OZA575-GM1	1895	1952
9-3 2.0T Cabrio	YS3F	2.0	129	08.03-		4	87	725	OZA583-GM2	1754	1952
9-3 2.0 16V Turbo	B204L	2.0	136	03.98-		3	77	1095	OZA446-E58	0483	0412
9-3 2.0 16V Turbo	B205R	2.0	140	01.99-		3	77	1095	OZA446-E58	0483	0412
9-3 2.0 16V Turbo	B204R	2.0	147	01.98-		3	77	1095	OZA446-E58	0483	0412
9-3 2.0 16V Turbo	B204L	2.0	147	09.98-		3	77	1095	OZA446-E58	0483	0412
9-3 2.0 16V Turbo	B204L	2.0	151	09.99-		3	77	1095	OZA446-E58	0483	0412
9-3 2.0T Cabrio	YS3F	2.0	154	08.03-		4	49	425	OZA575-GM1	1895	1952
9-3 2.0T Cabrio	YS3F	2.0	154	08.03-		4	87	725	OZA583-GM2	1754	1952
9-3 2.3i 16V	B234I	2.3	110	03.98-		3	77	1095	OZA446-E58	0483	0412
9-3 2.3i 16V Turbo	B235R	2.3	125	01.99-		3	77	1095	OZA446-E58	0483	0412
9-3 2.3i 16V Turbo	B234I	2.3	165	09.99-		3	77	1095	OZA446-E58	0483	0412

SEAT

Alhambra 2.0	ADY	2.0	85	03.96-		4	48	1430	OZA572-E10	0275	1919
Altea 1.6	BGU	1.6	75	06.04-		5	92	750	LZA07-V1	1851	---
Altea 1.6	BGU	1.6	75	06.04-		4	85	471	OZA510-V11	1884	---
Arosa 1.0i	ALL	1.0	37	10.97-		4	64	700	OZA447-E32	0471	1952
Arosa 1.0i	AER	1.0	37	02.97-		4	64	475	OZA448-E51	0426	1952
Arosa 1.4i	AEX	1.4	44	02.97-		4	64	700	OZA447-E32	0471	1952
Arosa 1.4i	AKV	1.4	44	05.97-		4	64	700	OZA447-E32	0471	1952
Arosa 1.4i	APQ	1.4	44	12.97-		4	64	700	OZA447-E32	0471	1952
Arosa 1.4i 16V	AUA	1.4	55	05.99-		4	64	1686	OZA510-V1	0491	1952
Arosa 1.4i 16V	AUA	1.4	55	05.99-		4	64	1576	OZA510-V2	0402	1952
Arosa 1.4i 16V	AUB	1.4	74	05.99-		4	64	1686	OZA510-V1	0491	1952
Arosa 1.4i 16V	AUB	1.4	74	05.99-		4	64	1576	OZA510-V2	0402	1952
Cordoba 1.0i	AER	1.0	37	09.96-06.99		4	48	520	OZA448-E31	0151	1952
Cordoba 1.2i 6L2	AZQ	1.2	47	10.02-		4	64	251	OZA510-V6	1885	1952
Cordoba 1.2i 6L2	AZQ	1.2	47	10.02-		4	85	481	OZA532-V3	1776	1952
Cordoba 1.2i	BMD	1.2	40	11.04-		4	64	611	OZA534-V1	1778	---
Cordoba 1.4i	AEX	1.4	44	09.95-12.97		4	48	520	OZA448-E31	0151	1952
Cordoba 1.4i	ABD	1.4	44	09.93-12.95	Fg.Nr. -> 6K-ZR700 000	4	36	550	OZA572-E1	0283	1919
Cordoba 1.4i	ABD	1.4	44	09.93-12.95	Fg.Nr. -> 6K-ZR155 000	4	36	550	OZA572-E1	0283	1919

Fg = Chassis No.

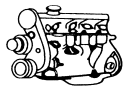

e kW



① ② ③

ORDER
No. No.
STOCK
No. No.
NUMBER
L. No.
SEAT

Cordoba 1.4i	BKY	1.4	55	06.04-		5	91	330	LZA07-V3	1880	---
Cordoba 1.4i 16V	6L2 BBY	1.4	55	10.02-		5	92	535	LZA11-V2	1774	---
Cordoba 1.4i 16V	6L2 BBY	1.4	55	10.02-		4	64	1596	OZA510-V10	1883	1952
Cordoba 1.4i 16V	6L2 BBY	1.4	55	10.02-		4	64	1706	OZA510-V7	1886	1952
Cordoba 1.4i 16V	AFH	1.4	74	07.96-		4	48	550	OZA447-E16	0259	1952
Cordoba 1.6	ALM	1.6	55	03.97-		4	48	550	OZA447-E16	0259	1952
Cordoba 1.6	AEE	1.6	55	03.97-12.98		4	48	550	OZA447-E16	0259	1952
Cordoba 1.6i	1F	1.6	55	09.94-09.97		4	48	520	OZA448-E31	0151	1952
Cordoba 1.6	ABU	1.6	55	03.93-07.94		4	36	550	OZA572-E1	0283	1919
Cordoba 1.6i	AFT	1.6	74	09.95-05.98		4	36	585	OZA572-E13	0254	1919
Cordoba 1.8	ABS	1.8	66	09.93-07.94		2	4	480	OZA401-E4	1822	1918
Cordoba 1.8	ABS	1.8	66	09.93-07.94		4	17	583	OZA446-E42	0150	1952
Cordoba 1.8i	ADZ	1.8	66	07.94-		4	48	520	OZA448-E31	0151	1952
Cordoba 1.8i Monotronic	ABS	1.8	66	02.93-09.94		4	48	520	OZA448-E31	0151	1952
Cordoba 1.8i 16V	ADL	1.8	95	09.93-06.96	Fg.Nr. 6K-ZR564 367 ->	4	36	585	OZA572-E13	0254	1919
Cordoba 2.0	2E	2.0	85	09.93-04.96		4	36	585	OZA572-E13	0254	1919
Cordoba 2.0 Digifant	2E	2.0	85	02.93-06.96		4	36	585	OZA572-E13	0254	1919
Ibiza 1.0i	AER	1.0	37	09.96-08.99		4	48	520	OZA448-E31	0151	1952
Ibiza 1.05	AAU	1.1	33	03.93-		4	36	550	OZA572-E1	0283	1919
Ibiza 1.2	BMD	1.2	40	11.04-		4	64	611	OZA534-V1	1778	---
Ibiza 1.2	6L1 AZQ	1.2	47	02.02-		4	64	251	OZA510-V6	1885	1952
Ibiza 1.2	6L1 AZQ	1.2	47	02.02-		4	85	481	OZA532-V3	1776	1952
Ibiza 1.2	021A00	1.2	51	12.89-05.93		3	19	975	OZA446-E2	1855	0412
Ibiza 1.3	AAV	1.3	40	03.93-07.94		4	36	550	OZA572-E1	0283	1919
Ibiza 1.4	ABD	1.4	40-44	09.93-12.95	Fg.Nr.-> 6K-ZR155 000	4	36	550	OZA572-E1	0283	1919
Ibiza 1.4	ABD	1.4	40-44	09.93-12.95	Fg.Nr.-> 6K-ZR700 00	4	36	550	OZA572-E1	0283	1919
Ibiza 1.4i	AEX	1.4	44	09.95-12.97		4	48	520	OZA448-E31	0151	1952
Ibiza 1.4i 16V	BBY	1.4	55	05.99-01.02		4	65	1326	OZA510-V3	0413	1952
Ibiza 1.4i 16V	6L1 BBY	1.4	55	02.02-		4	64	1706	OZA510-V7	1886	1952
Ibiza 1.4i 16V	AFH	1.4	74	07.96-		4	48	550	OZA447-E16	0259	1952
Ibiza 1.4i 16V	BBZ	1.4	74	05.99-		4	65	1326	OZA510-V3	0413	1952
Ibiza 1.5i	021 A2000	1.5	66	10.86-05.93		3	19	975	OZA446-E2	1855	0412
Ibiza 1.5i	021 A2000	1.5	70	11.89-05.93		3	19	975	OZA446-E2	1855	0412
Ibiza 1.6i	1F	1.6	55	05.94-09.97		2	4	480	OZA401-E4	1822	1918
Ibiza 1.6i	AEE	1.6	55	03.97-12.98		4	48	550	OZA447-E16	0259	1952
Ibiza 1.6i	1F	1.6	55	09.94-09.97		4	48	520	OZA448-E31	0151	1952
Ibiza 1.6i	ABU	1.6	55	03.93-07.94		4	36	550	OZA572-E1	0283	1919
Ibiza 1.6i	AFT	1.6	74	09.95-05.98		4	36	585	OZA572-E13	0254	1919
Ibiza 1.7i	021 B3000	1.7	76	01.91-05.93		3	19	975	OZA446-E2	1855	0412
Ibiza 1.8	ABS	1.8	66	03.93-07.94		4	17	583	OZA446-E42	0150	1952
Ibiza 1.8i Monotronic	ABS	1.8	66	02.93-09.94		4	48	520	OZA448-E31	0151	1952
Ibiza 1.8i	ADZ	1.8	66	07.94-		4	48	520	OZA448-E31	0151	1952
Ibiza 1.8 16 V	ADL	1.8	95	09.93-06.96		4	36	585	OZA572-E13	0254	1919
Ibiza 2.0	2E	2.0	85	03.93-04.96		4	36	585	OZA572-E13	0254	1919
Ibiza 2.0 Digifant	2E	2.0	85	02.93-06.96		4	36	585	OZA572-E13	0254	1919
Ibiza IV 1.4i	BKY	1.4	55	06.04-		5	91	330	LZA07-V3	1880	---
Ibiza IV 1.4i 16V	6L1 BBY	1.4	55	02.02-		5	92	535	LZA11-V2	1774	---
Ibiza IV 1.4i 16V	6L1 BBY	1.4	55	02.02-		4	64	1596	OZA510-V10	1883	1952
Leon 1.4i 16V	BCB	1.6	77	09.00-		5	92	810	LZA11-V4	1842	---
Leon 1.8i	AGN	1.8	92	12.99-		4	64	620	OZA447-E18	0281	1952
Malaga 1.2i	021 C1000	1.2	52	12.89-12.93		3	19	975	OZA446-E2	1855	0412
Malaga 1.5i	021 A2000	1.5	66	10.86-12.93		3	19	975	OZA446-E2	1855	0412

Fg = Chassis No.



ℓ kW



① ② ③

ORDER
No. No.
STOCK
No. No.
REVISION
No. No.**SEAT**

Malaga 1.5i	021 B2000	1.5	74	11.89-12.93		3	19	975	OZA446-E2	1855	0412
Malaga 1.7i		1.7	77	01.91-12.93		3	19	975	OZA446-E2	1855	0412
Marbella 0.9	09NCB	0.9	30	01.92-05.98		3	19	490	OZA446-E11	1898	0412
Toledo 1.6i	1F	1.6	55	05.91-11.93	Fg.Nr. -> 1L-ZD308 450	1	3	472	OZA401-E2	1802	1951
Toledo 1.6i	1F	1.6	55	11.93-	Fg.Nr. 1L-ZD308 451 ->	2	4	480	OZA401-E4	1822	1918
Toledo 1.6i	AKL	1.6	74	10.98-		4	64	470	OZA447-E17	0270	1952
Toledo 1.6i	AEH	1.6	74	10.98-		4	64	470	OZA447-E17	0270	1952
Toledo 1.8i	RP	1.8	66	05.91-11.93	Fg.Nr. -> 1L-ZD308 450	1	3	472	OZA401-E2	1802	1951
Toledo 1.8i	ABS	1.8	66	11.93-07.94	Fg.Nr. 1L-ZD308 451 ->	2	4	480	OZA401-E4	1822	1918
Toledo 1.8i	AGN	1.8	92	10.98-		4	64	620	OZA447-E18	0281	1952
Toledo 1.8i 16V	PL	1.8	95	05.91-11.93		3	19	975	OZA446-E2	1855	0412
					Fg.Nr. ->L-ZD308 450						
Toledo 2.0i	2E	2.0	85	05.91-03.94	Fg.Nr.-> 1L-ZD320 000	4	17	583	OZA446-E42	0150	1952
Toledo 2.0i	2E	2.0	85	03.94-01.95	Fg.Nr. 1L-ZD320 001-> 1L-ZR020 000	4	36	585	OZA572-E13	0254	1919
Toledo 2.0i 16V	ABF	2.0	110	03.94-01.95	Fg.Nr. 1L-ZD320 001-> 1L-ZR020 000	4	36	585	OZA572-E13	0254	1919
Toledo 2.3i V5	AGZ	2.3	110	10.98-		4	64	700	OZA447-E32	0471	1952

SKODA

Fabia 1.2i 2V	AWY	1.2	40	08.02-		4	65	231	OZA510-I1	1808	1952
Fabia 1.2i	BMD	1.2	40	11.04-		4	64	611	OZA534-V1	1778	---
Fabia 1.2i 2V	AWY	1.2	40	08.02-		4	64	601	OZA585-I1	1809	1952
Fabia 1.2i 6Y2 / 6Y3	AZQ	1.2	47	01.03-		4	64	251	OZA510-V6	1885	1952
Fabia 1.2i 6Y2 / 6Y3	AZQ	1.2	47	01.03-		4	85	481	OZA532-V3	1776	1952
Fabia 1.2 Kombi 6Y5	AZQ	1.2	47	01.03-		4	64	251	OZA510-V6	1885	1952
Fabia 1.2 Praktik	AZQ	1.2	47	05.03-		4	64	251	OZA510-V6	1885	1952
Fabia 1.2 Kombi 6Y5	AZQ	1.2	47	01.03-		4	85	481	OZA532-V3	1776	1952
Fabia 1.2 Praktik	AZQ	1.2	47	05.03-		4	85	481	OZA532-V3	1776	1952
Fabia 1.4i 16V	MN.7	1.4	55	09.99-	/	4	64	526	OZA510-V5	0435	1952
Fabia 1.4i	BKY	1.4	55	06.04-		5	91	330	LZA07-V3	1880	---
Fabia 1.4i 16V	MN.7	1.4	74	09.99-	/	4	64	526	OZA510-V5	0435	1952
Favorit 135	OHV	1.3	40	05.89-09.94		3	19	610	OZA446-E44	0162	0412
Felicia 135	MPI	1.3	40	08.96-		4	36	517	OZA447-E13	0183	1952
Felicia 136	MPI	1.3	50	08.96-		4	36	517	OZA447-E13	0183	1952
Felicia 1.3i	AMG	1.3	40	01.99-		4	36	516	OZA457-I1	0414	1952
Felicia 1.3i	AMH	1.3	50	01.99-		4	36	516	OZA457-I1	0414	1952
Felicia 1.4i 16V	MN.7	1.4	55	09.99-	/	4	64	526	OZA510-V5	0435	1952
Felicia 1.4i 16V	MN.7	1.4	74	09.99-	/	4	64	526	OZA510-V5	0435	1952
Felicia 1.6	MPI	1.6	55	09.95-		4	36	517	OZA447-E13	0183	1952
Octavia 1.6i	AEE	1.6	55	05.98-01.99	Fg.Nr. 1U-W109001 -> 1U-X197894	4	64	620	OZA447-E18	0281	1952
Octavia 1.6i 16V	AEH	1.6	74	04.97-	Fg.Nr. 1U-V-007 001 ->	4	64	470	OZA447-E17	0270	1952
Octavia 1.6	BGU	1.6	75	06.04-		5	92	750	LZA07-V1	1851	---
Octavia 1.6	BGU	1.6	75	06.04-		4	85	471	OZA510-V11	1884	---
Octavia 1.8i 20V	AGN	1.8	92	09.96-		4	64	620	OZA447-E18	0281	1952
Octavia 1.8i 20V Kombi	AGN	1.8	92	10.96-		4	64	620	OZA447-E18	0281	1952
Octavia 1.8 T	AGU	1.8	110	03.98-		4	64	700	OZA447-E32	0471	1952
Octavia 1.8 T Kombi	AGU	1.8	110	03.98-		4	64	700	OZA447-E32	0471	1952
Pick-Up 135	MPI	1.3	40	08.96-		4	36	517	OZA447-E13	0183	1952
Pick-Up 136	MPI	1.3	50	08.96-		4	36	517	OZA447-E13	0183	1952
Pick-Up 1.6	AEE MPI	1.6	55	10.95-		4	36	517	OZA447-E13	0183	1952

Fg = Chassis No.

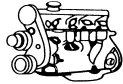

e kW



① ② ③

ORDER
STOCK
 No. No. L.No.
SSANGYONG

Musso 3.2i 24V	162.990	3.2	162	01.96-		4	41	750	OZA448-E38	0160	1952
----------------	---------	-----	-----	--------	--	---	----	-----	------------	------	------

STEYR-DAIMLER-PUCH

G 320	M112.945	3.2	158	01.98-		4	47	565	OZA447-E21	0216	1952
G 500	M113.962	5.0	218	01.98-		4	47	565	OZA447-E21	0216	1952

SUBARU

Justy II 1.3 GX 4x4	EF13	1.3	50	10.95-		1	6	320	OZA401-E6	1882	1951
Legacy 2.0i 16V 4WD	EJ20	2.0	85	05.92-12.93		3	80	440	OZA446-E55	0450	0412
Legacy 2.0i 16V	EJ20	2.0	85	05.92-12.93		3	80	440	OZA446-E55	0450	0412

SUZUKI

Samurai 1.3	SJ413	G13BA	1.3	51	01.90-		1	5	380	OZA401-E56	0154	1951
Swift 1.0	EA	G10A	1.0	39	10.91-		1	6	320	OZA401-E6	1882	1951
Swift 1.0	EA	G10A	1.0	40	12.89-09.91		1	6	320	OZA401-E6	1882	1951
Swift 1.3	EA	G13B	1.3	74	10.86-		1	6	445	OZA401-E58	0166	1951
Swift 1.3	EA	G13BA	1.3	50	10.91-07.94		1	6	320	OZA401-E6	1882	1951
Swift 1.3	EA	G13BA	1.3	52	12.89-09.91		1	6	320	OZA401-E6	1882	1951
Swift II 1.3	AH, AJ	G13A	1.3	50	08.94-		1	6	320	OZA401-E6	1882	1951
Swift II 1.6i	AH, AJ	G16B	1.6	68	01.90-		1	6	320	OZA401-E6	1882	1951
Swift II 1.6i 4x4	AH, AJ	G16B	1.6	68	01.90-		1	6	320	OZA401-E6	1882	1951
Vitara 1.6 Soft Top	ET	G16A	1.6	60	07.88-12.91		1	5	380	OZA401-E56	0154	1951
Vitara 1.6 SW	ET	G16A	1.6	60	07.88-12.91		1	5	380	OZA401-E56	0154	1951
Vitara 1.6	ET	G16A	1.6	60	08.88-08.91		1	5	380	OZA401-E56	0154	1951

TOYOTA

Avensis 1.6i 16V SW	T22	4A-FE	1.6	81	10.97-		4	34	310	OZA448-E47	0228	1952
Avensis 1.6i 16V	T22	4A-FE	1.6	81	10.97-		4	34	310	OZA448-E47	0228	1952
Avensis 1.6i 16V HB	T22	4A-FE	1.6	81	10.97-		4	34	310	OZA448-E47	0228	1952
Camry 2.2i 16V SW	V10	5FSE	2.2	100-103	03.92-07.96		4	34	300	OZA384-E39	0473	1952
Camry 2.2i 16V	V1	5FSE	2.2	100-103	06.91-08.96		4	34	300	OZA384-E39	0473	1952
Carina E 1.6	AT190	4A-FE	1.6	72-79	04.92-		-	-	-	-	-	-
Carina E 2.0i 16V	T19	3SFE	2.0	93	05.95-10.97		4	34	300	OZA384-E39	0473	1952
Carina E 2.0i 16V	T19	3SFE	2.0	93-98	12.92-10.97		4	34	300	OZA384-E39	0473	1952
Carina E 2.0i 16V LB	T19	3SFE	2.0	93-98	12.93-10.97		4	34	300	OZA384-E39	0473	1952
Carina E 2.0i 16V SW	T19	3SFE	2.0	98	11.92-01.96		4	34	300	OZA384-E39	0473	1952
Carina E 2.0i 16V	T19	3SFE	2.0	98	02.92-01.96		4	34	300	OZA384-E39	0473	1952
Carina E 2.0 GTi	T19	3SGE	2.0	116	04.92-01.96		4	34	338	OZA384-E40	0484	1952
Celica 1.6 STI	T18	4AFE	1.6	77	09.91-10.93		4	34	338	OZA384-E40	0484	1952
Corolla 1.3 LB	EE90	2E	1.3	55	08.87-04.92		1	7	340	OZA401-E49	0120	1951
Corolla 1.3 Sedan	EE90	2E	1.3	55	08.87-04.92		1	7	340	OZA401-E49	0120	1951
Corolla 1.3 SW	EE90	2E	1.3	55	08.87-04.92		1	7	340	OZA401-E49	0120	1951
Corolla 1.3 Compact	EE90	2E	1.3	55	08.87-04.92		1	7	340	OZA401-E49	0120	1951
Corolla 1.3	E10	4E-FE DOHC	1.3	65	08.92-09.95	OE	4	34	200	OZA448-E16	1839	1952
Corolla 1.6 Gti	E9	4A-GE	1.6	85	08.87-04.92		4	48	985	OZA447-E30	0449	1952
HiAce 2.4 4WD	H1	2RZE	2.4	88	08.89-07.95		4	34	338	OZA384-E40	0484	1952
HiAce 2.4	H1	2RZE	2.4	88	08.89-08.95		4	34	338	OZA384-E40	0484	1952
Previa 2.4	CR	2TZ-FE	2.4	97	10.90-		4	34	392	OZA384-E32	0133	1952
Starlet IV 1.4i 16V	EP91	4E-FE	1.4	55	01.96-		4	34	275	OZA502-E31	0250	1952

VOLVO

240 2.3 Injection SW	B230FD	2.3		08.92-08.93	Fg.Nr. -> 808999	3	19	975	OZA446-E2	1855	0412
----------------------	--------	-----	--	-------------	------------------	---	----	-----	-----------	------	------

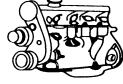

ℓ kW



① ② ③

ORDER
STOCK
 No. No. L No.
VOLVO

240 2.3 Injection	B230FD	2.3		08.92-08.93	Fg.Nr. -> 334099	3	19	975	OZA446-E2	1855	0412
240 2.3 Injection	B230F	2.3	84	08.84-07.88	Fg.Nr. -> 334099	3	19	975	OZA446-E2	1855	0412
240 2.3 Injection SW	B230F	2.3	84	08.84-07.88	Fg.Nr. -> 808999	3	19	975	OZA446-E2	1855	0412
440 1.6i	B16F	1.6	61	09.93-08.97		3	19	1665	OZA446-E49	0291	0412
440 1.7 Injection	B18F	1.7	70-75	09.88-08.91		3	19	1665	OZA446-E49	0291	0412
440 1.7 GL	B18FP	1.7	75	09.89-08.91		3	19	1665	OZA446-E49	0291	0412
440 1.7 Turbo	B18FT	1.7	88	09.88-08.91		3	19	1665	OZA446-E49	0291	0412
440 1.7 Turbo	B18FT	1.7	90	01.91-07.96		3	19	1665	OZA446-E49	0291	0412
440 1.8 Injection	B18U	1.8	66	09.91-08.97		3	19	1665	OZA446-E49	0291	0412
440 2.0i	B20F	2.0	80	09.92-12.96		3	19	1665	OZA446-E49	0291	0412
460 1.6 Injection	B16F	1.6	61	09.93-08.97		3	19	1665	OZA446-E49	0291	0412
460 1.8 Injection	B18U	1.8	66	09.91-08.97		3	19	1665	OZA446-E49	0291	0412
460 1.7 GLE	B18FP	1.7	75	03.90-08.91		3	19	975	OZA446-E2	1855	0412
460 1.7 GLE	B18FP	1.7	75	09.91-08.93	Fg.Nr. -> 603473	3	19	1665	OZA446-E49	0291	0412
460 2.0 Injection	B20F	2.0	80	09.92-12.96		3	19	1665	OZA446-E49	0291	0412
460 1.7 Turbo	B18FT	1.7	88	03.90-08.91		3	19	975	OZA446-E2	1855	0412
460 1.7 Turbo	B18FT	1.7	88	09.91-09.96	Fg.Nr. -> 603473	3	19	1665	OZA446-E49	0291	0412
480 1.7 ES	B18F	1.7	70-75	05.87-08.89		3	19	1665	OZA446-E49	0291	0412
480 1.7 Turbo	B18FT	1.7	88-90	08.88-08.95		3	19	1665	OZA446-E49	0291	0412
480 2.0 Injection	B20F	2.0	81	09.92-12.96		3	19	1665	OZA446-E49	0291	0412
740 2.0 Injection	B 200F	2.0	82	08.89-07.93	Fg.Nr. -> 294099	3	19	670	OZA446-E1	1833	0412
740 2.0 Injection	B 200F	2.0	82	08.89-07.93	Fg.Nr. 294100 ->	3	19	975	OZA446-E2	1855	0412
740 2.0 Injection SW	B 200F	2.0	82	08.89-07.93	Fg.Nr. -> 176799	3	19	670	OZA446-E1	1833	0412
740 2.0 Injection SW	B 200F	2.0	82	08.89-07.93	Fg.Nr. 176800 ->	3	19	975	OZA446-E2	1855	0412
740 2.0 Injection Turbo	B200FT	2.0	114	08.90-07.92		3	19	975	OZA446-E2	1855	0412
740 2.0i 16V Turbo Intercooler	B204GT	2.0	136	08.89-07.90	Ⓛ	3	19	885	OZA445-E6	0258	0412
740 2.0 Injection 16V Turbo Intercooler	B204FT	2.0	140	01.90-07.90	Ⓛ	3	19	975	OZA446-E2	1855	0412
740 2.3 Injection	B230F	2.3	85	08.88-08.94	Fg.Nr. -> 294099 🇪🇺	3	19	975	OZA446-E2	1855	0412
740 2.3 Injection SW	B230F	2.3	85	08.88-08.94	Fg.Nr. -> 176700 🇪🇺	3	19	975	OZA446-E2	1855	0412
740 2.3i	B230F	2.3	85	08.87-07.92		3	57	1700	OTA4F-3B1	1763	---
740 2.3 Injection Turbo Intercooler	B230FT	2.3	114-119	08.89-07.91		3	19	975	OZA446-E2	1855	0412
740 2.3i Turbo Intercooler	B230GT	2.3	120	08.89-07.90		3	19	885	OZA445-E6	0258	0412
760 2.3i Turbo	B230GT	2.3	120	08.89-07.90		3	19	885	OZA445-E6	0258	0412
760 2.3 Injection Turbo	B230FT	2.3	114-119	08.84-07.89		3	19	975	OZA446-E2	1855	0412
760 2.3 Injection Turbo	B230FT	2.3	114-119	08.89-07.92		3	19	975	OZA446-E2	1855	0412
760 2.8 Injection	B280F	2.8	105	05.86-10.86		3	19	1665	OZA446-E49	0291	0412
780 2.0i 16V Turbo Intercooler	B204GT	2.0	136	08.89-07.90		3	19	885	OZA445-E6	0258	0412
850 2.0	N2H20	2.0	93	05.94-		4	50	405	OTA4F-5B1	1901	---
850 2.0	B5204F	2.0	105	09.91-12.96	Fg.Nr. -> 70018 🇪🇺	4	38	880	OZA527-E4	0218	1919
850 2.0 SW	B5204F	2.0	105	09.91-08.96	Fg.Nr. -> 821 🇪🇺	4	38	880	OZA527-E4	0218	1919
850 2.5 Bi-Fuel	N2H25	2.5	103	08.97-04.99		4	81	570	OZA324-L1	1779	1952
850 2.5	N2H25	2.5	106	02.93-		4	50	405	OTA4F-5B1	1901	---
850 2.5i	N2H25	2.5	106	04.91-02.93		4	94	530	OTA4N-5A1	1755	---
850 2.5 GLT	B5254F	2.5	125	09.91-	Fg.Nr. -> 70018 🇪🇺	4	38	880	OZA527-E4	0218	1919
850 2.5 GLT SW	B5254F	2.5	125	09.91-	Fg.Nr. -> 821 🇪🇺	4	38	880	OZA527-E4	0218	1919
940 2.0 Turbo Intercooler	B200FT	2.0	114	09.91-08.93		3	19	975	OZA446-E2	1855	0412
940 2.3i	B230F	2.3	85	08.92-07.94		3	57	1700	OTA4F-3B1	1763	---
940 2.3i	B230F Regina	2.3	85	08.92-07.94		3	95	1900	OTA4F-3C1	1773	---
940 2.0 Turbo Intercooler	B230Ft	2.3	121	09.90-08.93	🇪🇺	3	19	975	OZA446-E2	1855	0412
960 2.0 Turbo Intercooler	B200FT	2.0	105	09.92-08.93	🇪🇺	3	19	975	OZA446-E2	1855	0412
960 2.0i 16V Turbo Intercooler	B204FT	2.0	140	09.91-08.93	🇪🇺	3	19	975	OZA446-E2	1855	0412
S40 1.6	B4164S	1.6	77	05.99-08.01		4	61	663	OTA4F-5F1	1908	---

Fg = Chassis No.

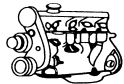

ℓ kW



① ② ③

ORDER
No. No.
STOCK
No. No.
NEW
PARTS
L. No.**VOLVO**

S40 1.6	B4164S	1.6	77	05.99-05.01		4	61	750	OTA4F-5G2	1927	---
S40 1.6	B4164S	1.6	77	01.96-04.99		4	29	1038	OZA83-VN1	0124	1952
S40 1.6i	B4164S2	1.6	80	08.00-		4	61	343	OTA4N-5F1	1795	---
S40 1.6i	B4164S2	1.6	80	04.99-01.00		4	61	750	OTA4N-5G1	1758	---
S40 1.6i	B4164S2	1.6	80	05.01-		4	61	750	OTA4N-5H1	1768	---
S40 1.6i	VS B 4164 S2	1.6	80	03.99-	Siemens	4	54	638	OTA7N-5D2	1975	---
S40 1.8i	B4184S	1.8	85	05.99-08.01		4	61	663	OTA4F-5F1	1908	---
S40 1.8i	B4184S	1.8	85	05.99-05.01		4	61	750	OTA4F-5G2	1927	---
S40 1.8i	B4184S	1.8	85	01.96-04.99		4	29	1038	OZA83-VN1	0124	1952
S40 1.8i	VS	1.8	90	03.99-	Siemens	4	54	638	OTA7N-5D2	1975	---
S40 1.8i		1.8	90	08.00-		4	61	343	OTA4N-5F1	1795	---
S40 1.8i		1.8	90	04.99-01.00		4	61	750	OTA4N-5G1	1758	---
S40 1.8i		1.8	90	05.01-		4	61	750	OTA4N-5H1	1768	---
S40 1.8i	B4184 5M	1.8	92	09.97-07.00		4	76	400	OZA448-E53	0448	1952
S40 1.9i	N1P19T	1.9	118	03.97-10.99		4	90	1362	OTA4N-5D1	1785	---
S40 T4	B4194T	1.9	147	03.97-04.00		4	62	1039	OTA4F-5C2	1948	---
S40 T4	B4194T	1.9	147	09.97-04.00		4	61	870	OTA4F-5E1	1942	---
S40 1.9i	N1P20LT	1.9	147	03.97-10.99		4	90	1362	OTA4N-5D1	1785	---
S40 2.0i	VS B4204S	2.0	100	07.95-07.00	Siemens	4	54	638	OTA7N-5D2	1975	---
S40 2.0i	B4204S	2.0	100	08.00-		4	61	343	OTA4N-5F1	1795	---
S40 2.0i	B4204S	2.0	100	04.99-01.00		4	61	750	OTA4N-5G1	1758	---
S40 2.0i	B4204S	2.0	100	05.01-		4	61	750	OTA4N-5H1	1768	---
S40 2.0i	B4204S	2.0	102	01.96-04.99		4	29	1038	OZA83-VN1	0124	1952
S40 2.0i	B4204S	2.0	103	05.99-08.01		4	61	663	OTA4F-5F1	1908	---
S40 2.0i	B4204S	2.0	103	05.99-05.01		4	61	750	OTA4F-5G2	1927	---
S40 2.0i	VS B4204S	2.0	103	07.95-04.99	Siemens	4	54	638	OTA7N-5D2	1975	---
S40 2.0i	VS B4204T	2.0	118	10.97-	Siemens	4	54	638	OTA7N-5D2	1975	---
S40 2.0 T	B4204T	2.0	118	03.97-04.00		4	62	1039	OTA4F-5C2	1948	---
S40 2.0 T	B4204T	2.0	118	09.97-04.00		4	61	870	OTA4F-5E1	1942	---
S40 2.0i	VS	2.0	120	06.01-	Siemens	4	54	638	OTA7N-5D2	1975	---
S40 2.0i	VS	2.0	121	07.00-	Siemens	4	54	638	OTA7N-5D2	1975	---
S40 2.0i	VS	2.0	147	07.00-	Siemens	4	54	638	OTA7N-5D2	1975	---
S40 2.5 Bi-Fuel	N2H25	2.5	103	09.01-	USA	4	61	1356	OZA324-L2	1780	1952
S40 2.5 Bi-Fuel	B4184	2.5	103	09.96-08.01	USA	4	61	1356	OZA324-L2	1780	1952
S70 2.5i	B5252S	2.5	106	01.97-11.00		4	50	530	OTA4N-5B1	1765	---
S80 T6	B 6284 T	2.8	200	05.98-		4	87	725	OZA583-GM2	1754	1952
S80 T6	B 6294 S	3.0	200	06.01-		4	87	725	OZA583-GM2	1754	1952
V40 1.6	B4164S	1.6	77	05.99-08.01		4	61	663	OTA4F-5F1	1908	---
V40 1.6	B4164S	1.6	77	05.99-05.01		4	61	750	OTA4F-5G2	1927	---
V40 1.6	B4164S	1.6	77	01.96-04.99		4	29	1038	OZA83-VN1	0124	1952
V40 1.6i	B4164S2	1.6	80	08.00-		4	61	343	OTA4N-5F1	1795	---
V40 1.6i	B4164S2	1.6	80	04.99-01.00		4	61	750	OTA4N-5G1	1758	---
V40 1.6i	B4164S2	1.6	80	05.01-		4	61	750	OTA4N-5H1	1768	---
V40 1.6i	VW B4164 S2	1.6	80	03.99-	Siemens	4	54	638	OTA7N-5D2	1975	---
V40 1.8i	B4184S	1.8	85	05.99-08.01		4	61	663	OTA4F-5F1	1908	---
V40 1.8i	B4184S	1.8	85	05.99-05.01		4	61	750	OTA4F-5G2	1927	---
V40 1.8i	B4184S	1.8	85	01.96-04.99		4	29	1038	OZA83-VN1	0124	1952
V40 1.8i	VW	1.8	90	03.99-07.00	Siemens	4	54	638	OTA7N-5D2	1975	---
V40 1.8i		1.8	90	08.00-		4	61	343	OTA4N-5F1	1795	---
V40 1.8i		1.8	90	04.99-01.00		4	61	750	OTA4N-5G1	1758	---
V40 1.8i		1.8	90	05.01-		4	61	750	OTA4N-5H1	1768	---
V40 1.8i	B4184 5M	1.8	92	09.97-07.00		4	76	400	OZA448-E53	0448	1952

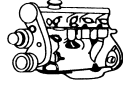

ℓ kW



① ② ③

ORDER
No. No.
STOCK
No. No.
REVISION
No. No.**VOLVO**

V40 1.9i	N1P19T	1.9	118	03.97-10.99		4	90	1362	OTA4N-5D1	1785	---
V40 T4	B4194T	1.9	147	03.97-04.00		4	62	1039	OTA4F-5C2	1948	---
V40 T4	B4194T	1.9	147	09.97-04.00		4	61	870	OTA4F-5E1	1942	---
V40 1.9i	N1P20LT	1.9	147	03.97-10.99		4	90	1362	OTA4N-5D1	1785	---
V40 2.0i	B4204S	2.0	100	08.00-		4	61	343	OTA4N-5F1	1795	---
V40 2.0i	B4204S	2.0	100	04.99-01.00		4	61	750	OTA4N-5G1	1758	---
V40 2.0i	B4204S	2.0	100	05.01-		4	61	750	OTA4N-5H1	1768	---
V40 2.0	VW B4204S	2.0	100	07.95-07.00	Siemens	4	54	638	OTA7N-5D2	1975	---
V40 2.0	B4204S	2.0	102	01.96-04.99		4	29	1038	OZA83-VN1	0124	1952
V40 2.0	B4204S	2.0	103	05.99-08.01		4	61	663	OTA4F-5F1	1908	---
V40 2.0	B4204S	2.0	103	05.99-05.01		4	61	750	OTA4F-5G2	1927	---
V40 2.0	VW B4204S	2.0	103	07.95-04.99	Siemens	4	54	638	OTA7N-5D2	1975	---
V40 2.0	VW B4204T	2.0	118	10.97-	Siemens	4	54	638	OTA7N-5D2	1975	---
V40 2.0 T	B4204T	2.0	118	03.97-04.00		4	62	1039	OTA4F-5C2	1948	---
V40 2.0 T	B4204T	2.0	118	09.97-04.00		4	61	870	OTA4F-5E1	1942	---
V40 2.0	VW	2.0	120	06.01-	Siemens	4	54	638	OTA7N-5D2	1975	---
V40 2.0	VW	2.0	121	07.00-	Siemens	4	54	638	OTA7N-5D2	1975	---
V40 2.0	VW	2.0	147	07.00-	Siemens	4	54	638	OTA7N-5D2	1975	---
V40 2.5 Bi-Fuel	N2H25	2.5	103	09.01-	USA	4	61	1356	OZA324-L2	1780	1952
V40 2.5 Bi-Fuel	B4184	2.5	103	09.96-08.01	USA	4	61	1356	OZA324-L2	1780	1952
V70 2.5i	B5252S	2.5	106	01.97-11.00		4	50	530	OTA4N-5B1	1765	---
V70 2.5 Bi-Fuel	B5252S	2.5	106	10.98-		4	81	570	OZA324-L1	1779	1952
XC 90 T6	B 6294 S	3.0	200	10.02-		4	87	725	OZA583-GM2	1754	1952

VW

Bora 1.6i	AKL	1.6	74	09.98-		4	64	470	OZA447-E17	0270	1952
Bora 1.6i 16V	AUS	1.6	77	07.99-		4	65	541	OZA510-V4	0424	1952
Bora 1.6i 16V	AZD	1.6	77	07.99-		4	65	541	OZA510-V4	0424	1952
Bora 1.6i 16V	ATN	1.6	77	07.99-		4	65	541	OZA510-V4	0424	1952
Bora 1.6i 16V	1J2 BCB	1.6	77	05.00-		5	92	810	LZA11-V4	1842	---
Bora 1.6i 16V	1J2 AZD	1.6	77	05.00-		5	92	810	LZA11-V4	1842	---
Bora 1.6i 16V	1J2 ATN	1.6	77	05.00-		5	92	810	LZA11-V4	1842	---
Bora 1.6i 16V	1J2 AUS	1.6	77	05.00-		5	92	810	LZA11-V4	1842	---
Bora 1.6i 16V Variant	1J6 BCB	1.6	77	02.00-		5	92	810	LZA11-V4	1842	---
Bora 1.6i 16V Variant	1J6 AZD	1.6	77	02.00-		5	92	810	LZA11-V4	1842	---
Bora 1.6i 16V Variant	1J6 ATN	1.6	77	02.00-		5	92	810	LZA11-V4	1842	---
Bora 1.6i 16V Variant	1J6 AUS	1.6	77	02.00-		5	92	810	LZA11-V4	1842	---
Bora 1.8i 20V 4motion	AGN	1.8	92	02.99-		4	64	620	OZA447-E18	0281	1952
Bora 1.8i 4 Motion	AGN	1.8	92	02.99-		4	64	620	OZA447-E18	0281	1952
Bora 1.8i 20V	AGN	1.8	92	10.98-		4	64	620	OZA447-E18	0281	1952
Bora 1.8i	AGN	1.8	92	09.98-		4	64	620	OZA447-E18	0281	1952
Bora 2.3 VR5 Variant	AGZ	2.3	110	05.99-		4	64	700	OZA447-E32	0471	1952
Bora 2.3 VR5 4motion	AGZ	2.3	110	01.99-		4	64	700	OZA447-E32	0471	1952
Bora 2.3 VR5	AGZ	2.3	110	09.98-		4	64	700	OZA447-E32	0471	1952
Bus 2.1	SR	2.1	64	08.86-07.92		3	19	975	OZA446-E2	1855	0412
Bus 2.1	SS	2.1	68	08.89-07.92		3	19	975	OZA446-E2	1855	0412
Bus 2.1	MV	2.1	70	08.85-07.92		3	19	975	OZA446-E2	1855	0412
Caddy 1.6	AEE	1.6	55	06.96-		4	36	517	OZA447-E13	0183	1952
Caddy 1.6	AEE	1.6	55	06.97-		4	48	550	OZA447-E16	0259	1952
Caddy 1.8	JH	1.8	70	08.85-07.92		1	3	472	OZA401-E2	1802	1951
Caddy II 1.4i	AEX	1.4	44	11.95-		4	48	720	OZA447-E31	0460	1952
Caddy III Kasten 1.6	BGU	1.6	75	06.04-		5	92	680	LZA07-V2	1868	---

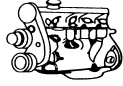

e kW



① ② ③

ORDER
STOCK
 No. No.

VW
 No. No.

Caddy III Life 1.6	BGU	1.6	75	06.04-		5	92	680	LZA07-V2	1868	---
California 2.0	AAC	2.0	62-64	01.96-	Fg.Nr. T200 001 ->	3	14	1220	OZA446-E3	1866	0412
California 2.0	AAC	2.0	62-64	09.90-12.95	Fg.Nr. -> T-200 000	3	46	545	OZA446-E51	0215	0412
California 2.5 Syncro	AAF	2.5	80-81	11.92-12.93	Fg.Nr. -> T200 000	3	46	335	OZA446-E53	0237	0412
California 2.5	AAF	2.5	80-81	11.90-12.93	Fg.Nr. -> T200 000	3	46	335	OZA446-E53	0237	0412
California 2.5	ACU	2.5	81	07.94-10.96	Fg.Nr. -> T200 000	3	46	335	OZA446-E53	0237	0412
Caravelle 2.0	AAC	2.0	62-64	09.90-12.95	Fg.Nr. -> T-200 000	3	46	545	OZA446-E51	0215	0412
Caravelle 2.5	AAF	2.5	80-81	11.90-12.93	Fg.Nr. -> T200 000	3	46	335	OZA446-E53	0237	0412
Caravelle 2.5	ACU	2.5	81	07.94-10.96	Fg.Nr. -> T200 000	3	46	335	OZA446-E53	0237	0412
Caravelle 2.5 Syncro	ACU	2.5	81	07.94-12.95	Fg.Nr. -> T200 000	3	46	335	OZA446-E53	0237	0412
Corrado 1.8 G60	PG	1.8	118	09.88-06.89	Fg.Nr. -> 50-K-015 000	3	18	970	OZA446-E15	1848	0412
Corrado 1.8 G60	PG	1.8	118	09.88-06.89	Fg.Nr. -> 50 K-011 579	3	18	970	OZA446-E15	1848	0412
Corrado 1.8 G60	PG	1.8	118	09.88-09.93		3	46	430	OZA446-E52	0226	0412
Corrado 2.0	9A	2.0	100	08.91-		3	46	430	OZA446-E52	0226	0412
Corrado 2.0	ADY	2.0	85	09.94-10.94	Fg.Nr. -> 50-S-000 719	4	36	585	OZA572-E13	0254	1919
Corrado 2.0	2E	2.0	85	04.93-09.94	Fg.Nr. -> 50-S-000 719	4	36	585	OZA572-E13	0254	1919
Corrado 2.9 VR6	ABV	2.9	140	08.91-10.94	Fg.Nr. -> 50-S-000 719	4	36	585	OZA572-E13	0254	1919
Eurovan 2.5	ACU	2.5	81	01.96-05.96	Fg.Nr. T200001 ->	3	14	1220	OZA446-E3	1866	0412
Golf Cabriolet 1.8	AAM	1.8	55	09.93-11.94	Fg.Nr. ->1E-S-012 000	2	4	480	OZA401-E4	1822	1918
Golf Cabriolet 1.8	AAM	1.8	55	09.93-		4	17	583	OZA446-E42	0150	1952
Golf Cabriolet 1.8	AAM	1.8	55	03.95-07.95	Fg.Nr. 1E-S-024 274 ->	4	48	520	OZA448-E31	0151	1952
Golf Cabriolet 1.8	ABS	1.8	66	09.93-11.94	Fg.Nr. -> 1E-S-012 000	2	4	480	OZA401-E4	1822	1918
Golf Cabriolet 1.8	ABS	1.8	66	09.93-07.95		4	17	583	OZA446-E42	0150	1952
Golf Cabriolet 1.8	ADZ	1.8	66	03.95-07.95	Fg.Nr. 1E-S-024 274 ->	4	48	520	OZA448-E31	0151	1952
Golf Cabriolet 1.8	ABS	1.8	66	03.95-07.95	Fg.Nr. 1E-S-024 274 ->	4	48	520	OZA448-E31	0151	1952
Golf Cabriolet 1.8	JH	1.8	70	08.83-08.93		1	3	472	OZA401-E2	1802	1951
Golf Cabriolet 1.8	2H	1.8	74	08.89-08.93		4	17	583	OZA446-E42	0150	1952
Golf Cabriolet 2.0	2E	2.0	85	09.93-09.94		4	36	585	OZA572-E13	0254	1919
Golf II 1.3	NZ	1.3	40	08.87-07.90	Fg.Nr. 19-J-000001 ->	3	18	960	OZA445-E3	1860	0412
Golf II 1.3	NZ	1.3	40	02.87-07.87	1G-L-990000						
Golf II 1.3	NZ	1.3	40	02.87-07.87	Fg.Nr. 19-H-000001 ->	3	18	970	OZA446-E15	1848	0412
Golf II 1.3	NZ	1.3	40	08.90-07.92	19-H-990000						
Golf II 1.3	NZ	1.3	40	08.90-07.92	Fg.Nr. 1G-M-000001 ->	4	17	920	OZA445-E4	1850	1952
Golf II 1.6	PN	1.6	51	08.87-07.92		1	3	472	OZA401-E2	1802	1951
Golf II 1.8	GX	1.8	66	01.84-05.88		1	3	472	OZA401-E2	1802	1951
Golf II 1.8	RP	1.8	66	11.87-10.91		1	3	472	OZA401-E2	1802	1951
Golf II 1.8 Syncro	GX	1.8	66	02.86-07.88		3	19	975	OZA446-E2	1855	0412
Golf II 1.8 Syncro	1P	1.8	66-72	08.88-07.91		3	18	970	OZA446-E15	1848	0412
Golf II 1.8	PF	1.8	79	01.87-10.91		3	18	970	OZA446-E15	1848	0412
Golf II 1.8	RD	1.8	79	08.85-10.87		3	19	975	OZA446-E2	1855	0412
Golf II 1.8	PB	1.8	82	01.87-10.91		1	3	472	OZA401-E2	1802	1951
Golf II 1.8 16V	PL	1.8	95	02.86-10.91		3	19	975	OZA446-E2	1855	0412
Golf II 1.8 16V	KR	1.8	102	02.86-10.91		1	3	472	OZA401-E2	1802	1951
Golf II 1.8 Rallye	1H	1.8	118	04.89-12.89		3	18	970	OZA446-E15	1848	0412
Golf II 1.8 G60	PG	1.8	118	04.90-07.91		4	17	583	OZA446-E42	0150	1952
Golf III 1.4 Variant	ABD	1.4	40-44	10.94-07.95	Fg.Nr. S-120 001 ->	4	48	550	OZA447-E16	0259	1952
Golf III 1.4	ABD	1.4	40-44	09.94-07.95	Fg.Nr. 1H-S-120 001 ->	4	48	550	OZA447-E16	0259	1952
Golf III 1.4	ABD	1.4	40-44	11.91-09.94	Fg.Nr. -> 1H-S-120 000	4	36	550	OZA572-E1	0283	1919
Golf III 1.6	AEE	1.6	55	10.94-12.97	Fg.Nr. 1H-S-120 001 ->	4	48	550	OZA447-E16	0259	1952
Golf III 1.6	AEA	1.6	55	10.94-12.97	Fg.Nr. 1H-S-120 001 ->	4	48	550	OZA447-E16	0259	1952
Golf III 1.6	ABU	1.6	55	09.92-09.94	Fg.Nr. -> 1H-S-120 000	4	36	550	OZA572-E1	0283	1919

Fg = Chassis No.

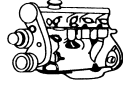

ℓ kW



① ② ③

ORDER
No. No. STOCK
REVISIONS
L.No.**VW**

Golf III 1.8	AAM	1.8	55	11.91-09.94		2	4	480	OZA401-E4	1822	1918
					Fg.Nr. -> 1H-S-120 000						
Golf III 1.8	AAM	1.8	55	11.91-09.94		4	17	583	OZA446-E42	0150	1952
					Fg.Nr. -> 1H-S-120 000						
Golf III 1.8	ABS	1.8	66	11.91-09.94		2	4	480	OZA401-E4	1822	1918
					Fg.Nr. -> 1H-S-120 000						
Golf III 1.8	ABS	1.8	66	11.91-09.94		4	17	583	OZA446-E42	0150	1952
					Fg.Nr. -> 1H-S-120 000						
Golf III 1.8	ADZ	1.8	66	10.94-12.97		4	48	520	OZA448-E31	0151	1952
Golf III 2.0 Variant Syncro	AGG	2.0	85	07.95-04.97	Fg.Nr. -> 1H-V-800 000	4	48	780	OZA572-E11	0251	1919
Golf III 2.0 Variant Syncro	AGG	2.0	85	05.97-	Fg.Nr. 1H-W-000 001 ->	4	48	780	OZA572-E11	0251	1919
Golf III 2.0 Syncro	AGG	2.0	85	07.95-12.97		4	48	780	OZA572-E11	0251	1919
Golf III 2.0	2E	2.0	85	11.91-09.94		4	36	585	OZA572-E13	0254	1919
Golf III 2.0 Variant	2E	2.0	85	07.93-09.94		4	36	585	OZA572-E13	0254	1919
Golf III 2.8 VR 6	AAA	2.8	128	01.92-08.94		4	36	550	OZA572-E1	0283	1919
Golf III 2.8 VR 6	AAA	2.8	128	09.94-		4	48	620	OZA572-E9	0423	1919
Golf III 2.9 VR6 Syncro	ABV	2.9	140	07.95-12.97		4	48	1430	OZA447-E36	1950	1952
Golf III 2.9 VR6 Syncro	ABV	2.9	140	10.94-07.95	Fg.Nr. 1H-S 120 001 ->	4	36	585	OZA572-E13	0254	1919
					1H-S 990 000						
Golf IV 1.4i	AKQ	1.4	55	10.97-		4	64	620	OZA447-E18	0281	1952
Golf IV 1.4i Variant	AKQ	1.4	55	05.99-		4	64	620	OZA447-E18	0281	1952
Golf IV 1.6i	AEH	1.6	74	01.98-10.98	Fg.Nr. -> 1J-X 260 000	4	64	470	OZA447-E17	0270	1952
Golf IV 1.6i	AKL	1.6	74	10.97-10.98		4	64	470	OZA447-E17	0270	1952
					Fg.Nr. -> 1J-X 260 000						
Golf IV 1.6i 16V	AZD	1.6	77	07.99-		4	65	541	OZA510-V4	0424	1952
Golf IV 1.6i 16V	ATN	1.6	77	07.99-		4	65	541	OZA510-V4	0424	1952
Golf IV 1.6i 16V	AUS	1.6	77	07.99-		4	65	541	OZA510-V4	0424	1952
Golf IV 1.6i 16V 1J1	BCB	1.6	77	02.00-		5	92	810	LZA11-V4	1842	---
Golf IV 1.6i 16V 1J1	AZD	1.6	77	02.00-		5	92	810	LZA11-V4	1842	---
Golf IV 1.6i 16V 1J1	ATN	1.6	77	02.00-		5	92	810	LZA11-V4	1842	---
Golf IV 1.6i 16V 1J1	AUS	1.6	77	02.00-		5	92	810	LZA11-V4	1842	---
Golf IV 1.6i 16V Variant 1J5	BCB	1.6	77	02.00-		5	92	810	LZA11-V4	1842	---
Golf IV 1.6i 16V Variant 1J5	AZD	1.6	77	02.00-		5	92	810	LZA11-V4	1842	---
Golf IV 1.6i 16V Variant 1J5	ATN	1.6	77	02.00-		5	92	810	LZA11-V4	1842	---
Golf IV 1.6i 16V Variant 1J5	AUS	1.6	77	02.00-		5	92	810	LZA11-V4	1842	---
Golf IV 1.8i	AGN	1.8	92	10.97-		4	64	620	OZA447-E18	0281	1952
Golf IV 1.8i 4 Motion	AGN	1.8	92	10.97-		4	64	620	OZA447-E18	0281	1952
Golf IV 1.8i	AGU	1.8	110	10.97-		4	64	620	OZA447-E18	0281	1952
Golf IV 1.8i 20V	AGU	1.8	110	10.97-		4	64	700	OZA447-E32	0471	1952
Golf IV 2.3 VR5	AGZ	2.3	110	10.97-		4	64	700	OZA447-E32	0471	1952
Golf IV 2.3 VR5 4motion	AGZ	2.3	110	11.98-		4	64	700	OZA447-E32	0471	1952
Golf IV 2.3 VR5 Variant	AGZ	2.3	110	05.99-		4	64	700	OZA447-E32	0471	1952
Jetta 1.3	NZ	1.3	40	08.87-07.90		3	18	960	OZA445-E3	1860	0412
Jetta 1.3	NZ	1.3	40	02.87-07.87		3	18	970	OZA446-E15	1848	0412
Jetta 1.3	NZ	1.3	40	08.90-07.92		4	17	920	OZA445-E4	1850	1952
Jetta 1.6	PN	1.6	51	10.86-07.92		1	3	472	OZA401-E2	1802	1951
Jetta 1.8	GX	1.8	66	08.84-10.87		1	3	472	OZA401-E2	1802	1951
Jetta 1.8	RP	1.8	66	11.87-10.91		1	3	472	OZA401-E2	1802	1951
Jetta 1.8	RP	1.8	66	10.87-10.91		3	19	975	OZA445-E7	0269	0412
Jetta 1.8 Syncro	GX	1.8	66	08.87-07.88		3	19	975	OZA446-E2	1855	0412
Jetta 1.8 Syncro	1P	1.8	66-72	08.88-07.92		3	18	970	OZA446-E15	1848	0412
Jetta 1.8	PF	1.8	79	02.87-07.92		3	18	970	OZA446-E15	1848	0412

Fg = Chassis No.

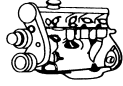

e kW



① ② ③

ORDER
STOCK
NUMBER
PL. No.
L. No.
VW

Jetta 1.8	RD	1.8	79	08.85-10.87		3	19	975	OZA446-E2	1855	0412
Jetta 1.8	PB	1.8	82	02.87-10.91		1	3	472	OZA401-E2	1802	1951
Jetta 1.8i 16V	PL	1.8	95	08.86-10.91		3	19	975	OZA446-E2	1855	0412
Jetta 1.8 16V	KR	1.8	102	08.86-10.91		1	3	472	OZA401-E2	1802	1951
Käfer 1600	ACD	1.6	34	10.92-09.95	Fg.Nr. -> S-999 000	3	18	970	OZA446-E15	1848	0412
Käfer 1600	ACD	1.6	34	08.96-	Fg.Nr. -> V-000 001	4	36	550	OZA572-E1	0283	1919
LT 31 2.4	1E	2.4	70	10.88-04.96		3	18	970	OZA446-E15	1848	0412
LT 35 2.4	1E	2.4	70	10.88-04.96		3	18	970	OZA446-E15	1848	0412
LT 40 2.4	1E	2.4	70	10.88-04.96		3	18	970	OZA446-E15	1848	0412
Lupo 1.0i	ALL	1.0	37	10.98-		4	64	700	OZA447-E32	0471	1952
Lupo 1.0i	AER	1.0	37	10.98-		4	64	475	OZA448-E51	0426	1952
Lupo 1.4 16V	6X1, 6E1	1.4	55	11.01-		5	92	535	LZA11-V2	1774	- - -
Lupo 1.4 16V	6X1, 6E1	1.4	55	11.01-		4	64	1596	OZA510-V10	1883	1952
Lupo 1.4 16V	6X1, 6E1	1.4	55	11.01-		4	64	1706	OZA510-V7	1886	1952
Lupo 1.4i 16V	AHW	1.4	55	10.98-		4	64	700	OZA447-E32	0471	1952
Lupo 1.4i 16V	AUA	1.4	55	05.99-		4	64	1686	OZA510-V1	0491	1952
Lupo 1.4i 16V	AUA	1.4	55	05.99-		4	64	1576	OZA510-V2	0402	1952
Lupo 1.4i 16V	AFK	1.4	74	10.98-		4	64	700	OZA447-E32	0471	1952
Lupo 1.4i 16V	ANM	1.4	74	05.99-		4	64	700	OZA447-E32	0471	1952
Lupo 1.4i 16V	AUB	1.4	74	05.99-		4	64	1686	OZA510-V1	0491	1952
Lupo 1.4i 16V	AUB	1.4	74	05.99-		4	64	1576	OZA510-V2	0402	1952
Multivan 2.0	AAC	2.0	62-64	01.96-	Fg.Nr. T200 001 ->	3	14	1220	OZA446-E3	1866	0412
Multivan 2.0	AAC	2.0	62-64	09.90-12.95	Fg.Nr. -> T-200 000	3	46	545	OZA446-E51	0215	0412
Multivan 2.5 Syncro	AAF	2.5	80-81	11.92-12.93	Fg.Nr. -> T200 000	3	46	335	OZA446-E53	0237	0412
Multivan 2.5	AAF	2.5	80-81	11.90-12.93	Fg.Nr. -> T200 00	3	46	335	OZA446-E53	0237	0412
Multivan 2.5	ACU	2.5	81	01.96-	Fg.Nr. T200 001 ->	3	14	1220	OZA446-E3	1866	0412
Multivan 2.5 Syncro	ACU	2.5	81	07.94-10.96	Fg.Nr. -> T200 000	3	46	335	OZA446-E53	0237	0412
Multivan 2.5	ACU	2.5	81	07.94-10.96	Fg.Nr. -> T200 00	3	46	335	OZA446-E53	0237	0412
Passat 1.6	1F	1.6	51	08.88-04.90	Fg.Nr. -> 31-L-300 00	1	3	472	OZA401-E2	1802	1951
Passat 1.6i	ANA	1.6	74	07.99-09.00		4	65	700	OZA334-AU1	0474	1952
Passat 1.6	AHL	1.6	74	10.96-11.00		4	48	967	OZA447-E14	0129	1952
Passat 1.6	ADP	1.6	74	10.96-12.98		4	48	967	OZA447-E14	0129	1952
Passat 1.6i	ANA	1.6	74	07.99-09.00		4	64	1055	OZA516-AU1	0452	1952
Passat 1.6i	ALZ	1.6	75	10.00-		4	65	700	OZA334-AU1	0474	1952
Passat 1.6i	ALZ	1.6	75	10.00-		4	64	1055	OZA516-AU1	0452	1952
Passat 1.8	AAM	1.8	55	08.90-03.97		4	17	583	OZA446-E42	0150	1952
Passat 1.8	AAM	1.8	55	07.95-03.97	Fg.Nr. 3A-T-000 001 ->	4	48	520	OZA448-E31	0151	1952
Passat 1.8	RP	1.8	66	04.88-04.90	Fg.Nr. -> 31-L-300 000	1	3	472	OZA401-E2	1802	1951
Passat 1.8	ABS	1.8	66	08.91-09.94	Fg.Nr. -> 3A-S-075 00	2	4	480	OZA401-E4	1822	1918
Passat 1.8	ABS	1.8	66	08.91-09.94		4	17	583	OZA446-E42	0150	1952
Passat 1.8	ADS	1.8	66	07.95-03.97	Fg.Nr. 3A-T-000 001 ->	4	48	520	OZA448-E31	0151	1952
Passat 1.8	ADZ	1.8	66	10.94-12.96		4	48	520	OZA448-E31	0151	1952
Passat 1.8	JN	1.8	66-68	08.84-03.88		1	3	472	OZA401-E2	1802	1951
Passat 1.8 Syncro	JN	1.8	68	01.86-03.88		3	19	975	OZA446-E2	1855	0412
Passat 1.8	PF	1.8	79	04.88-07.90		3	18	970	OZA446-E15	1848	0412
Passat 1.8	ADR	1.8	92	10.96-		4	48	967	OZA447-E14	0129	1952
Passat 1.8 T 20V Variant	AEB	1.8	110	05.97-12.98		4	66	1140	OZA447-E25	0494	1952
Passat 1.8 T 20V	AEB	1.8	110	10.96-12.98		4	66	1140	OZA447-E25	0494	1952
Passat 2.0i	AZM	2.0	85	11.00-		4	65	700	OZA334-AU1	0474	1952
Passat 2.0	2E	2.0	85	08.90-07.94	Fg.Nr. -> 3A-R-300 000	4	17	583	OZA446-E42	0150	1952
Passat 2.0i	AZM	2.0	85	11.00-		4	64	1055	OZA516-AU1	0452	1952
Passat 2.0	2E	2.0	85	07.94-09.94	Fg.Nr. 3A-R-300 001 ->	4	36	622	OZA527-E14	0455	1919

Fg = Chassis No.

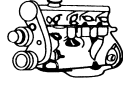

ℓ kW



① ② ③

ORDER
No. No. STOCK
No. No. L.No.**VW**

Passat 2.0 Syncro	AGG	2.0	85	07.95-03.97		4	48	780	OZA572-E11	0251	1919
Passat 2.0 Syncro	ADY	2.0	85	10.94-12.95		4	48	780	OZA572-E11	0251	1919
Passat 2.0	ADY	2.0	85	10.94-12.95		4	48	620	OZA572-E9	0423	1919
Passat 2.0i	ASU	2.0	88	11.99-10.00		4	65	700	OZA334-AU1	0474	1952
Passat 2.0i	ASU	2.0	88	10.99-10.00		4	64	1055	OZA516-AU1	0452	1952
Passat 2.0i 16V	9A	2.0	100	08.88-07.90		3	19	975	OZA446-E2	1855	0412
Passat 2.0i 16V	9A	2.0	100	08.90-09.93	Fg.Nr. -> 3A-R-300 000	4	17	583	OZA446-E42	0150	1952
Passat 2.2	KX	2.2	85	08.85-03.88		1	3	472	OZA401-E2	1802	1951
Passat 2.2 Syncro	JT	2.2	88	08.85-03.88		3	19	975	OZA446-E2	1855	0412
Passat 2.8 VR6	AAA	2.8	128	06.91-07.94	Fg.Nr. -> 3A-R-400 000	4	36	585	OZA572-E13	0254	1919
Passat 2.8 VR6	AAA	2.8	128	07.94-07.95	Fg.Nr. 3A-S-000 001 -> 3A-T-000 209	4	48	620	OZA572-E9	0423	1919
Passat 2.8 V6 Syncro	ACK	2.8	142	01.97-04.97	Fg.Nr. ->3B-V-120 000	4	48	520	OZA448-E31	0151	1952
Polo 1.0i	AER	1.0	37	03.96-12.99		4	64	475	OZA448-E51	0426	1952
Polo 1.05	AAU	1.0	33	10.90-09.94		4	17	920	OZA445-E4	1850	1952
Polo 1.05 Van	AAU	1.0	33	04.93-09.94		4	17	920	OZA445-E4	1850	1952
Polo 1.05	AEV	1.05	33	10.94-12.99		4	48	985	OZA447-E30	0449	1952
Polo 1.2	BMD	1.2	40	11.04-		4	64	611	OZA534-V1	1778	- - -
Polo 1.2 2V	AWY	1.2	40	01.02-		4	65	231	OZA510-I1	1808	1952
Polo 1.2 2V	AWY	1.2	40	01.02-		4	64	601	OZA585-I1	1809	1952
Polo 1.2	9N AZQ	1.2	47	10.01-		4	64	251	OZA510-V6	1885	1952
Polo 1.2	9N AZQ	1.2	47	10.01-		4	85	481	OZA532-V3	1776	1952
Polo 1.3	NZ	1.3	40	10.87-08.90	Fg.Nr. 80-J-600001 ->	3	18	960	OZA445-E3	1860	0412
Polo 1.3	NZ	1.3	40	12.86-09.87	Fg.Nr. -> 80-J-060000	3	18	970	OZA446-E15	1848	0412
Polo 1.3	AAV	1.3	40	08.91-09.94		4	17	450	OZA445-E2	1810	1952
Polo 1.3	AAV	1.3	40	01.91-07.91		4	17	920	OZA445-E4	1850	1952
Polo 1.3	NZ	1.3	40	10.90-12.92		4	17	920	OZA445-E4	1850	1952
Polo 1.3	ADX	1.3	40	10.94-07.95		4	48	985	OZA447-E30	0449	1952
Polo 1.3	3F	1.3	56-59	10.89-08.90		3	18	970	OZA446-E15	1848	0412
Polo 1.3	3F	1.3	56-59	10.90-09.94		4	17	920	OZA445-E4	1850	1952
Polo 1.3 G40	PY	1.3	82-85	10.90-09.94		4	17	920	OZA445-E4	1850	1952
Polo 1.4i	AEX	1.4	44	07.95-12.99		4	48	985	OZA447-E30	0449	1952
Polo 1.4i	AEX	1.4	44	07.95-10.99		4	48	720	OZA447-E31	0460	1952
Polo 1.4i Classic	AEX	1.4	44	05.97-11.97		4	48	720	OZA447-E31	0460	1952
Polo 1.4i 16V Classic	AEX	1.4	44	05.97-11.97	Fg.Nr. 6K-X 541 001->	4	64	700	OZA447-E32	0471	1952
Polo 1.4i 16V Classic	AKV	1.4	44	05.97-11.97	Fg.Nr. 6K-X 541 001->	4	64	700	OZA447-E32	0471	1952
Polo 1.4i 16V	AEX	1.4	44	05.97-	Fg.Nr. 6N-W 000 001->	4	64	700	OZA447-E32	0471	1952
Polo 1.4i 16V Van	AEX	1.4	44	05.98-12.99	Fg.Nr. 6N-W 000 001->	4	64	700	OZA447-E32	0471	1952
Polo 1.4i 16V Van	APQ	1.4	44	05.98-12.99	Fg.Nr. 6N-W 000 001->	4	64	700	OZA447-E32	0471	1952
Polo 1.4i 16V	APQ	1.4	44	05.97-	Fg.Nr. 6N-W 000 001->	4	64	700	OZA447-E32	0471	1952
Polo 1.4 Variant	AEX	1.4	44	03.97-04.97		4	48	520	OZA448-E31	0151	1952
Polo 1.4i 16V	APE	1.4	55	07.99-10.01	/	4	64	1686	OZA510-V1	0491	1952
Polo 1.4i 16V	APE	1.4	55	07.99-10.01	/	4	64	1576	OZA510-V2	0402	1952
Polo 1.4i 16V	APE	1.4	55	11.01-		4	64	526	OZA510-V5	0435	1952
Polo 1.4i 16V	BKY	1.4	55	06.04-		5	91	330	LZA07-V3	1880	- - -
Polo 1.4i 16V	BBY	1.4	55	11.01-		5	92	465	LZA11-V3	1829	- - -
Polo 1.4i 16V	AFH	1.4	74	04.96-12.99		4	48	985	OZA447-E30	0449	1952
Polo 1.4i 16V	AFH	1.4	74	05.98-		4	64	700	OZA447-E32	0471	1952
Polo 1.4i 16V	BBZ	1.4	74	07.99-11.01	Fg.Nr. 6N-X 068 039->	4	64	1686	OZA510-V1	0491	1952
Polo 1.4i 16V	BBZ	1.4	74	07.99-11.01	/	4	64	1576	OZA510-V2	0402	1952
Polo 1.4i 16V	BBZ	1.4	74	11.01-	/	4	64	526	OZA510-V5	0435	1952

Fg = Chassis No.

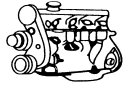

ℓ kW



① ② ③

ORDER
STOCK
 NUMBER
 SERIAL
 A.L.No.
VW

Polo 1.6 Variant	AEE	1.6	55	04.97-		4	48	550	OZA447-E16	0259	1952
Polo 1.6 Classic	AEE	1.6	55	04.97-		4	48	550	OZA447-E16	0259	1952
Polo 1.6	AEA	1.6	55	10.94-07.95		4	48	985	OZA447-E30	0449	1952
Polo 1.6	AEE	1.6	55	07.95-12.99		4	48	985	OZA447-E30	0449	1952
Polo 1.6i 16V GTI	AJV	1.6	88	09.98-10.99		4	64	700	OZA447-E32	0471	1952
Santana 1.8	JN	1.8	68	08.84-12.84		1	3	472	OZA401-E2	1802	1951
Scirocco 1.8	JH	1.8	68-70	05.83-07.92		1	3	472	OZA401-E2	1802	1951
Scirocco 1.8i 16V	PL	1.8	92-95	02.86-07.92		3	19	975	OZA446-E2	1855	0412
Sharan 2.0	ADY	2.0	85	09.95-	Fg.Nr. -> 7M-T-036 895	4	48	1430	OZA572-E10	0275	1919
Sharan 2.8 VR6 Syncro	AAA	2.8	128	11.96-01.98		4	48	720	OZA447-E31	0460	1952
Sharan 2.8 VR6	AAA	2.8	128	09.95-01.98		4	48	720	OZA447-E31	0460	1952
Sharan 2.8i VR6	AAA	2.8	128	02.98-04.00		4	48	1430	OZA447-E36	1950	1952
Touran 1.6i	BGU	1.6	75	07.03-		5	92	750	LZA07-V1	1851	- - -
Touran 1.6i	BGU	1.6	75	07.03-		4	85	471	OZA510-V11	1884	- - -
Transporter 2.0	AAC	2.0	62-64	01.96-	Fg.Nr. T200 001 ->	3	14	1220	OZA446-E3	1866	0412
Transporter 2.0	AAC	2.0	62-64	09.90-12.95	Fg.Nr. -> T-200 000	3	46	545	OZA446-E51	0215	0412
Transporter 2.1	SR	2.1	64	10.86-07.92		3	19	975	OZA446-E2	1855	0412
Transporter 2.1	SS	2.1	68	08.89-07.92		3	19	975	OZA446-E2	1855	0412
Transporter 2.1 Syncro	MV	2.1	70	08.85-07.92		3	19	975	OZA446-E2	1855	0412
Transporter 2.1	MV	2.1	70	08.85-07.92		3	19	975	OZA446-E2	1855	0412
Transporter 2.5	ACU	2.5	81	01.96-08.96	Fg.Nr. T200 001 ->	3	14	1220	OZA446-E3	1866	0412
Transporter 2.5 Syncro	AAF	2.5	80-81	11.92-12.93	Fg.Nr. -> T200 000	3	46	335	OZA446-E53	0237	0412
Transporter 2.5	AAF	2.5	80-81	11.90-12.93	Fg.Nr. -> T200 000	3	46	335	OZA446-E53	0237	0412
Transporter 2.5	ACU	2.5	81	01.94-10.96	Fg.Nr. -> T200 000	3	46	335	OZA446-E53	0237	0412
Transporter 2.5 Syncro	ACU	2.5	81	01.94-10.96	Fg.Nr. -> T200 000	3	46	335	OZA446-E53	0237	0412
Transporter IV 2.8 VR6	AES	2.8	103	01.96-10.97		4	48	720	OZA447-E31	0460	1952
Vento 1.4	ABD	1.4	40-44	09.94-07.95	Fg.Nr. 1H-S-120 001 ->	4	48	550	OZA447-E16	0259	1952
Vento 1.4	ABD	1.4	40-44	11.91-09.94	Fg.Nr. -> 1H-S-120 000	4	36	550	OZA572-E1	0283	1919
Vento 1.6	AEE	1.6	55	10.94-	Fg.Nr. 1H-S-120 001 ->	4	48	550	OZA447-E16	0259	1952
Vento 1.6	AEA	1.6	55	10.94-	Fg.Nr. 1H-S-120 001 ->	4	48	550	OZA447-E16	0259	1952
Vento 1.6	ABU	1.6	55	09.92-09.94	Fg.Nr. -> 1H-S-120 000	4	36	550	OZA572-E1	0283	1919
Vento 1.8	AAM	1.8	55	11.91-09.94		2	4	480	OZA401-E4	1822	1918
					Fg.Nr. -> 1H-S-120 000						
Vento 1.8	AAM	1.8	55	11.91-09.94		4	17	583	OZA446-E42	0150	1952
					Fg.Nr. -> 1H-S-120 000						
Vento 1.8	ABS	1.8	66	11.91-09.94		2	4	480	OZA401-E4	1822	1918
					Fg.Nr. -> 1H-S-120 000						
Vento 1.8	ABS	1.8	66	11.91-09.94		4	17	583	OZA446-E42	0150	1952
					Fg.Nr. -> 1H-S-120 000						
Vento 1.8	ADZ	1.8	66	10.94-07.95		4	48	520	OZA448-E31	0151	1952
Vento 2.0	2E	2.0	85	11.91-09.94		4	36	585	OZA572-E13	0254	1919
Vento 2.0	AGG	2.0	85	07.95-		4	48	620	OZA572-E9	0423	1919
Vento 2.0	ADY	2.0	85	10.94-05.96		4	48	620	OZA572-E9	0423	1919
Vento 2.8 VR6	AAA	2.8	128	09.94-07.95		4	48	620	OZA572-E9	0423	1919

ZASTAVA

Florida 1.3	OHC-M5	1.3	50	07.89-12.90		1	3	472	OZA401-E2	1802	1951
Florida 1.3	OHC-M5	1.3	50	01.91-12.93		3	19	490	OZA446-E11	1898	0412
Yugo 60 i.e.	OHC-M4	1.1	44	07.89-05.90		1	3	472	OZA401-E2	1802	1951
Yugo 65 i.e.	OHC-M5	1.3	47	07.89-05.90		1	3	472	OZA401-E2	1802	1951
Yugo 1.3i.e. Cabrio	OHC-M5	1.3	48	07.89-05.90		1	3	472	OZA401-E2	1802	1951
Yugo 65 i.e.	OHC.M5	1.3	47	06.90-12.93		3	19	490	OZA446-E11	1898	0412

Fg = Chassis No.

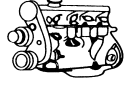

ℓ kW



① ② ③

STOCK
No. No. 1898 0412

ZASTAVA

Yugo 1.3 i.e.Cabrio	OHC-M5	1.3	48	06.90-12.93		3	19	490	OZA446-E11	1898	0412
---------------------	--------	-----	----	-------------	--	---	----	-----	------------	------	------

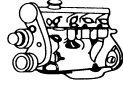

l kW



① ② ③

ORDER
STOCK
No. No.

APRILIA

RSV 1000 R	Rotax V2	1.0	102	04.04-		4	31	590	OZA591-SZ1	1767
RSV 1000 R Factory	Rotax V2	1.0	102	10.03-		4	31	590	OZA591-SZ1	1767

BMW

F 650 CS		0.7	25-37	11.01-		4	68	340	OZA447-E28	0427
F 650 GS		0.7	37	09.99-		4	68	340	OZA447-E28	0427
F 650 GS Dakar		0.7	37	09.99-		4	68	340	OZA447-E28	0427

Датчик → Производитель транспортного средства

ORDER	NTK	APPLICATION
0120	OZA401-E49	TOYOTA
0121	OZA428-E3	MINISUBISHI
0122	OZA253-F6	MAZDA
0123	OZA55-R2	RENAULT
0124	OZA83-VN1	VOLVO
0125	OZA216-D3	FORD
0126	OZA311-R2	RENAULT
0128	OZA446-E41	OPEL
0129	OZA447-E14	AUDI / VW
0131	OZA401-E50	NISSAN
0132	OZA428-E4	MINISUBISHI
0133	OZA384-E32	TOYOTA
0134	OZA55-R3	RENAULT
0135	OZA89-D2	FORD
0136	OZA222-RV1	ROVER
0137	OZA333-H4	HONDA / ROVER
0138	OZA447-E10	BMW
0139	OZA446-E46	FORD
0142	OZA401-E51	NISSAN
0143	OZA401-E55	MAZDA
0145	OZA55-R4	RENAULT
0146	OZA112-A1	FIAT / LANCIA
0147	OZA236-R1	RENAULT
0148	OZA333-H5	HONDA
0150	OZA446-E42	HONDA / SEAT / VW
0151	OZA448-E31	AUDI / SEAT / VW
0152	OZA448-E37	LANCIA
0153	OZA401-E57	HONDA
0154	OZA401-E56	HONDA / SUZUKI
0155	OZA446-E45	NISSAN
0156	OZA83-R1	RENAULT
0157	OZA112-A3	FIAT / LANCIA
0158	OZA236-R2	RENAULT
0159	OZA333-H6	HONDA
0160	OZA448-E38	MERCEDES / SSANGYONG
0162	OZA446-E44	LANCIA / SKODA
0164	OZA401-E52	HONDA
0165	OZA85-M1	MINISUBISHI
0166	OZA401-E58	SUZUKI
0167	OZA83-R2	RENAULT
0168	OZA201-AM1	ASTON MARTIN
0169	OZA245-H1	HONDA / ROVER
0175	OZA401-E53	MINISUBISHI
0176	OZA25-F3	MAZDA
0177	OZA73-F1	MAZDA
0178	OZA83-R3	RENAULT
0179	OZA201-AM2	ASTON MARTIN
0180	OZA245-H2	HONDA / ROVER
0182	OZA448-E29	MERCEDES
0183	OZA447-E13	SKODA / VW
0186	OZA401-E54	MINISUBISHI
0187	OZA25-F1	MAZDA

ORDER	NTK	APPLICATION
0188	OZA186-F5	MAZDA
0189	OZA83-R4	RENAULT
0190	OZA216-D2	FORD
0191	OZA311-R1	RENAULT
0193	OZA446-E40	OPEL
0194	OZA446-E43	AUDI
0197	OZA428-E2	MINISUBISHI
0198	OZA25-F12	MAZDA
0199	OZA33-D5	FORD
0201	OZA527-E3	CITROEN / FIAT / LANCIA / PEUGEOT
0204	OZA446-E50	AUDI
0206	OZA448-E45	MERCEDES
0207	OZA401-E63	MINISUBISHI
0209	OZA572-E8	BMW / BERTONE
0210	OZA448-E39	FORD
0212	OZA333-H27	HONDA
0213	OZA527-E7	ALFA ROMEO / AUTOBIANCHI / FIAT / LANCIA
0215	OZA446-E51	VW
0216	OZA447-E21	MERCEDES / STEYR-DAIMLER-PUCH
0218	OZA527-E4	ALFA ROMEO / AUTOBIANCHI / FERRARI / FIAT / INNOCENTI / LANCIA / VOLVO
0220	OZA527-E12	CITROEN / PEUGEOT
0223	OZA334-A1	FIAT / LANCIA
0225	OZA112-A2	FIAT
0226	OZA446-E52	VW
0227	OZA447-E22	MERCEDES
0228	OZA448-E47	TOYOTA
0234	OZA334-A2	FIAT / LANCIA
0236	OZA112-A4	FIAT
0237	OZA446-E53	VW
0239	OZA448-E48	FORD
0242	OZA572-E5	BMW
0244	OZA519-D1	FORD
0245	OZA334-A3	FIAT
0250	OZA502-E31	TOYOTA
0251	OZA572-E11	VW
0252	OZA572-E2	BMW
0253	OZA527-E5	ALFA ROMEO / FIAT / LANCIA
0254	OZA572-E13	SEAT / VW
0255	OZA421-H1	HONDA
0256	OZA21-F3	MAZDA
0258	OZA445-E6	FIAT / VOLVO
0259	OZA447-E16	AUDI / SEAT / VW
0260	OZA448-E41	FORD
0263	OZA527-E10	MERCEDES
0264	OZA572-E3	BMW
0265	OZA527-E2	PEUGEOT
0266	OZA501-H17	HONDA
0269	OZA445-E7	AUDI / VW
0270	OZA447-E17	AUDI / SEAT / SKODA / VW
0271	OZA448-E42	FORD

Датчик → Производитель транспортного средства

ORDER	NTK	APPLICATION
0273	OZA572-E12	BMW
0274	OZA527-E22	CITROEN / PEUGEOT
0275	OZA572-E10	SEAT / VW
0277	OZA333-H19	HONDA
0280	OZA446-E48	FIAT / PEUGEOT
0281	OZA447-E18	AUDI / SEAT / SKODA / VW
0282	OZA448-E43	RENAULT
0283	OZA572-E1	SEAT / VW
0284	OZA527-E8	ROVER
0285	OZA527-E13	MERCEDES
0286	OZA573-E1	TOYOTA
0287	OZA527-E24	ALFA ROMEO / LANCIA
0288	OZA333-H25	HONDA
0291	OZA446-E49	ALFA ROMEO / AUDI / HONDA / VOLVO
0293	OZA448-E44	FORD
0295	OZA572-E4	BMW
0296	OZA527-E19	FIAT
0298	OZA527-E15	CITROEN / PEUGEOT
0299	OZA333-H26	HONDA
0401	OZA74-F1	FORD / MAZDA
0402	OZA510-V2	SEAT / VW
0403	OZA488-D1	JAGUAR
0404	OZA448-E49	OPEL
0405	OZA447-E26	OPEL
0406	OZA401-E66	MINI
0407	OZA334-SZ3	OPEL
0408	OZA572-E14	BMW
0409	OZA532-A3	FIAT / LANCIA
0413	OZA510-V3	SEAT
0414	OZA457-I1	SKODA
0415	OZA448-E50	RENAULT
0416	OZA447-E27	BMW / LAND ROVER
0417	OZA401-E67	MINI
0418	OZA334-SZ4	OPEL
0420	OTA7H-3C2	OPEL
0423	OZA572-E9	VW
0424	OZA510-V4	VW
0425	OZA502-E28	HONDA
0426	OZA448-E51	SEAT / VW
0427	OZA447-E28	BMW
0428	OZA401-E68	MINI
0429	OZA341-RV2	ROVER
0430	OZA527-E18	ROVER
0431	OTA7L-3C4	OPEL
0433	OZA74-F2	MAZDA
0434	OZA527-E16	CITROEN / PEUGEOT
0435	OZA510-V5	SKODA / VW
0436	OZA502-E34	MINI
0437	OZA448-E52	MINI
0438	OZA447-E29	BMW / LAND ROVER
0440	OZA341-W2	DAEWOO
0442	OTA7L-3C3	OPEL

ORDER	NTK	APPLICATION
0445	OZA527-E17	CITROEN / PEUGEOT
0446	OZA74-F3	MAZDA
0447	OZA502-E35	MINI
0448	OZA448-E53	MINI, VOLVO
0449	OZA447-E30	AUDI / TOYOTA / VW
0450	OZA446-E55	MINI
0451	OZA381-D2	JAGUAR
0452	OZA516-AU1	AUDI / VW
0453	OTD3G-3A1	LAND ROVER / MG / ROVER
0455	OZA527-E14	VW
0457	OZA186-F7	MAZDA
0458	OZA502-E36	MINI
0459	OZA448-E54	MERCEDES
0460	OZA447-E31	AUDI / FORD / VW
0461	OZA446-E56	HYUNDAI
0462	OZA381-D3	ASTON MARTIN / JAGUAR
0463	OZA527-E6	MERCEDES
0464	OTD3J-5B1	DAIMLER / JAGUAR
0466	OZA527-E27	BMW
0468	OZA277-R2	RENAULT
0469	OZA501-H23	HONDA
0470	OZA448-E55	FORD
0471	OZA447-E32	AUDI / SEAT / SKODA / VW
0472	OZA446-E57	RENAULT
0473	OZA384-E39	NISSAN / TOYOTA
0474	OZA334-AU1	AUDI / VW
0475	OTD3J-5C1	LAND ROVER
0477	OZA527-E28	FORD
0478	OZA532-A1	FIAT
0480	OZA507-R2	RENAULT
0481	OZA448-E56	CITROEN / FIAT / LANCIA / PEUGEOT
0482	OZA447-E34	MERCEDES
0483	OZA446-E58	SAAB
0484	OZA384-E40	MERCEDES / TOYOTA
0485	OZA334-SZ1	OPEL
0486	OTA7H-5A1	BMW
0488	OZA527-E29	CITROEN / PEUGEOT
0489	OZA532-A2	FIAT / LANCIA
0491	OZA510-V1	SEAT / VW
0492	OZA448-E57	CITROEN / PEUGEOT
0493	OZA447-E35	AUDI
0494	OZA447-E25	AUDI / VW
0496	OZA334-SZ2	OPEL
0498	OZA527-E9	MG / ROVER
0499	OZA569-H1	HONDA
1753	OZA583-GM1	OPEL
1754	OZA583-GM2	SAAB / VOLVO
1755	OTA4N-5A1	VOLVO
1757	OZA488-D2	FORD
1758	OTA4N-5G1	VOLVO
1759	OZA112-A6	FIAT
1760	OZA112-A7	FIAT

Датчик → Производитель транспортного средства

ORDER	NTK	APPLICATION
1762	OZA534-A1	FIAT
1763	OTA4F-3B1	VOLVO
1764	OZA534-A2	FIAT / LANCIA
1765	OTA4N-5B1	VOLVO
1766	OZA488-SZ1	FORD
1767	OZA591-SZ1	APRILIA
1768	OTA4N-5H1	VOLVO
1772	LZA07-AU1	AUDI
1773	OTA4F-3C1	VOLVO
1774	LZA11-V2	SEAT / VW
1776	OZA532-V3	SEAT / SKODA / VW
1777	OZA572-E6	BMW
1778	OZA534-V1	SEAT / SKODA / VW
1779	OZA324-L1	VOLVO
1780	OZA324-L2	VOLVO
1782	OZA510-AU1	AUDI
1783	OZA510-AU2	AUDI
1784	OZA510-AU3	AUDI
1785	OTA4N-5D1	VOLVO
1786	OZA532-A4	FIAT
1789	OZA334-AU2	AUDI
1790	OZA334-PG1	CITROEN / PEUGEOT
1792	OZA532-A5	LANCIA
1793	OZA532-A9	FIAT
1794	OZA532-A10	FIAT
1795	OTA4N-5F1	VOLVO
1796	OZA532-A7	FIAT
1798	OZA341-A1	FIAT
1800	OZA534-A3	LANCIA
1802	OZA401-E2	AUDI / FIAT / LANCIA / NISSAN / RENAULT / SAAB / SEAT / VW / ZASTAVA
1804	OZA544-N8	NISSAN / RENAULT
1805	OZA446-E12	AUDI
1807	OZA428-E1	RENAULT
1808	OZA510-I1	SKODA / VW
1809	OZA585-I1	SKODA / VW
1810	OZA445-E2	VW
1813	OZA341-PG5	CITROEN / PEUGEOT
1814	OZA341-PG6	CITROEN / PEUGEOT
1815	OZA341-PG7	CITROEN
1816	OZA341-PG8	CITROEN
1818	OZA538-PG1	CITROEN / PEUGEOT
1819	OZA538-PG2	CITROEN / PEUGEOT
1820	OZA381-D1	FORD
1822	OZA401-E4	SEAT / VW
1825	LZA11-V1	AUDI
1826	OZA446-E13	MERCEDES
1827	OZA446-E8	RENAULT
1828	OZA401-E5	ROVER
1829	LZA11-V3	VW
1833	OZA446-E1	AUTOBIANCHI / FERRARI / FIAT / LANCIA / SAAB / VOLVO

ORDER	NTK	APPLICATION
1836	OZA571-C10	MERCEDES
1837	OZA446-E14	MERCEDES
1838	OZA446-E5	ALFA ROMEO
1839	OZA448-E16	TOYOTA
1840	LZA06-U1	CITROEN / PEUGEOT
1842	LZA11-V4	SEAT / VW
1845	OZA600-BM2	BMW
1846	OZA600-BM5	BMW
1847	OZA600-BM7	BMW
1848	OZA446-E15	VW
1850	OZA445-E4	VW
1851	LZA07-V1	AUDI / SEAT / SKODA / VW
1852	OZA495-PG2	CITROEN / PEUGEOT
1853	OZA495-PG3	PEUGEOT
1855	OZA446-E2	AUDI / CITROEN / FIAT / HYUNDAI / JAGUAR / LANCIA / SEAT / VOLVO / VW
1856	OZA114-A1	FIAT / INNOCENTI
1857	OZA544-R1	NISSAN / RENAULT
1859	OZA446-E16	AUDI / LANCIA / SAAB
1860	OZA445-E3	VW
1861	OZA446-E6	OPEL
1862	OZA531-GM1	OPEL
1863	OZA531-GM2	OPEL
1864	OZA531-GM3	OPEL
1865	OZA448-E12	FORD
1866	OZA446-E3	HONDA / OPEL / VW
1867	OZA33-D8	FORD
1868	LZA07-V2	VW
1869	OZA531-GM6	OPEL
1870	OZA531-GM7	CHEVROLET / PONTIAC
1872	OZA446-E7	MERCEDES
1877	OZA446-E4	ALFA ROMEO / AUTOBIANCHI / FIAT / INNOCENTI / JAGUAR / LANCIA
1878	OZA55-R1	RENAULT
1880	LZA07-V3	SEAT / SKODA / VW
1882	OZA401-E6	DAEWOO / OPEL / SUBARU / SUZUKI
1883	OZA510-V10	SEAT / VW
1884	OZA510-V11	AUDI / SEAT / SKODA / VW
1885	OZA510-V6	SEAT / SKODA / VW
1886	OZA510-V7	SEAT / VW
1887	OZA446-E18	ALFA ROMEO / FIAT / LANCIA
1889	OZA65-A2	FIAT
1890	OZA89-D1	FORD
1891	OZA531-GM16	OPEL
1892	OZA531-GM22	OPEL
1893	OZA448-E13	FIAT
1895	OZA575-GM1	SAAB
1896	OZA575-GM2	OPEL
1898	OZA446-E11	AUDI / CITROEN / PEUGEOT / RENAULT / SEAT / ZASTAVA
1901	OTA4F-5B1	VOLVO
1907	OTD2F-3K1	NISSAN

Рекомендационный перечень

GENUINE	NTK	ORDER
ALFA ROMEO		
161 241 101 601	OZA446-E4	1877
464 442 84	OZA527-E7	0213
464 620 06	OZA527-E24	0287
596 351 60	OZA401-E2	1802
605 076 900	OZA446-E4	1877
605 376 500	OZA446-E49	0291
605 677 59	OZA446-E5	1838
605 765 30	OTA5F-3C1	1921
605 765 300	OTA5F-3C1	1921
606 053 74	OTA6F-3A1	1928
608 090 12	OZA446-E1	1833
761 930 300	OZA446-E4	1877
ASTON MARTIN		
SPD 5551	OZA201-AM1	0168
SPD 5552	OZA201-AM2	0179
XR3F 9G444 BA	OZA381-D3	0462
AUDI		
030 906 265 AD	OZA447-E16	0259
048 906 265 B	OZA446-E50	0204
051 906 265 D	OZA445-E7	0269
053 906 265	OZA445-E7	0269
06A 906 265 E	OZA447-E17	0270
06A 906 265 H	OZA447-E18	0281
06B 906 265 A	OZA334-AU1	0474
06B 906 265 B	OZA516-AU1	0452
077 906 265 B	OZA445-E7	0269
078 906 265 B	OZA446-E50	0204
BERU		
0 824 010 003	OZA527-E27	0466
0 824 010 004	OZA446-E49	0291
0 824 010 005	OZA447-E10	0138
0 824 010 006	OZA527-E22	0274
0 824 010 007	OZA446-E46	0139
0 824 010 008	OZA446-E13	1826
0 824 010 009	OZA445-E4	1850
0 824 010 010	OZA446-E42	0150
0 824 010 011	OZA446-E51	0215
0 824 010 012	OZA446-E45	0155
0 824 010 013	OZA445-E2	1810
0 824 010 014	OZA448-E12	1865
0 824 010 015	OZA216-D3	0125
0 824 010 017	OZA448-E38	0160
0 824 010 018	OZA446-E50	0204
0 824 010 020	OZA446-E40	0193
0 824 010 021	OZA448-E42	0271
0 824 010 022	OZA527-E13	0285
0 824 010 023	OZA572-E11	0251
0 824 010 026	OZA448-E45	0206

GENUINE	NTK	ORDER
BERU		
0 824 010 027	OZA446-E14	1837
0 824 010 028	OZA445-E6	0258
0 824 010 030	OZA446-E3	1866
0 824 010 031	OZA527-E2	0265
0 824 010 032	OZA572-E4	0295
0 824 010 033	OZA445-E4	1850
0 824 010 034	OZA446-E7	1872
0 824 010 035	OZA446-E8	1827
0 824 010 036	OZA527-E3	0201
0 824 010 037	OZA527-E4	0218
0 824 010 038	OZA572-E2	0252
0 824 010 038	OZA572-E8	0209
0 824 010 039	OZA446-E2	1855
0 824 010 040	OZA527-E12	0220
0 824 010 041	OZA572-E12	0273
0 824 010 042	OZA446-E6	1861
0 824 010 043	OZA527-E10	0263
0 824 010 044	OZA527-E6	0463
0 824 010 045	OZA572-E1	0283
0 824 010 046	OZA446-E11	1898
0 824 010 047	OZA448-E44	0293
0 824 010 048	OZA446-E16	1859
0 824 010 049	OZA446-E15	1848
0 824 010 050	OZA445-E3	1860
0 824 010 051	OZA114-A1	1856
0 824 010 052	OZA33-D8	1867
0 824 010 053	OZA401-E4	1822
0 824 010 054	OZA401-E57	0153
0 824 010 055	OZA401-E6	1882
0 824 010 056	OZA446-E13	1826
0 824 010 057	OZA446-E18	1887
0 824 010 058	OZA527-E9	0498
0 824 010 059	OZA448-E13	1893
0 824 010 060	OZA527-E5	0253
0 824 010 061	OZA527-E7	0213
0 824 010 062	OZA527-E8	0284
0 824 010 063	OZA236-R1	0147
0 824 010 063	OZA55-R1	1878
0 824 010 064	OZA65-A2	1889
0 824 010 065	OZA33-D5	0199
0 824 010 065	OZA89-D1	1890
0 824 010 068	OZA527-E4	0218
0 824 010 070	OZA527-E19	0296
0 824 010 072	OZA446-E48	0280
0 824 010 075	OZA447-E14	0129
0 824 010 076	OZA447-E16	0259
0 824 010 080	OZA527-E15	0298
0 824 010 081	OZA527-E28	0477
0 824 010 084	OZA253-F6	0122
0 824 010 089	OZA527-E17	0445
0 824 010 090	OZA401-E50	0131

Рекомендационный перечень

GENUINE	NTK	ORDER
BERU		
0 824 010 094	OZA401-E2	1802
0 824 010 096	OZA401-E55	0143
0 824 010 098	OZA55-R4	0145
0 824 010 099	OZA112-A1	0146
0 824 010 102	OZA448-E31	0151
0 824 010 104	OZA401-E56	0154
0 824 010 105	OZA83-R1	0156
0 824 010 106	OZA112-A3	0157
0 824 010 107	OZA236-R2	0158
0 824 010 111	OZA401-E58	0166
0 824 010 112	OZA83-R2	0167
0 824 010 114	OZA527-E18	0430
0 824 010 117	OZA73-F1	0177
0 824 010 118	OZA83-R3	0178
0 824 010 120	OZA448-E29	0182
0 824 010 121	OZA447-E13	0183
0 824 010 124	OZA186-F5	0188
0 824 010 125	OZA83-R4	0189
0 824 010 127	OZA311-R1	0191
0 824 010 128	OZA446-E43	0194
0 824 010 129	OZA527-E16	0434
0 824 010 131	OZA25-F12	0198
0 824 010 133	OZA401-E51	0142
0 824 010 139	OZA446-E57	0472
0 824 010 143	OZA428-E1	1807
0 824 010 152	OZA334-A1	0223
0 824 010 154	OZA245-H1	0169
0 824 010 155	OZA245-H2	0180
0 824 010 156	OZA333-H5	0148
0 824 010 157	OZA333-H26	0299
0 824 010 159	OZA311-R2	0126
0 824 010 161	OZA447-E17	0270
0 824 010 164	OZA83-VN1	0124
0 824 010 165	OZA446-E52	0226
OZH 002	OZA527-E27	0466
OZH 003	OZA446-E49	0291
OZH 004	OZA447-E10	0138
OZH 005	OZA527-E22	0274
OZH 006	OZA446-E46	0139
OZH 007	OZA446-E13	1826
OZH 008	OZA445-E4	1850
OZH 009	OZA446-E42	0150
OZH 010	OZA446-E51	0215
OZH 011	OZA446-E45	0155
OZH 012	OZA445-E2	1810
OZH 013	OZA448-E12	1865
OZH 014	OZA216-D3	0125
OZH 016	OZA448-E38	0160
OZH 017	OZA446-E50	0204
OZH 019	OZA446-E40	0193
OZH 020	OZA448-E42	0271

GENUINE	NTK	ORDER
BERU		
OZH 021	OZA527-E13	0285
OZH 022	OZA572-E11	0251
OZH 025	OZA448-E45	0206
OZH 026	OZA446-E14	1837
OZH 027	OZA445-E6	0258
OZH 028	OZA446-E3	1866
OZH 029	OZA527-E2	0265
OZH 030	OZA572-E4	0295
OZH 031	OZA445-E4	1850
OZH 032	OZA446-E7	1872
OZH 033	OZA446-E8	1827
OZH 034	OZA527-E3	0201
OZH 035	OZA527-E4	0218
OZH 036	OZA572-E2	0252
OZH 036	OZA572-E8	0209
OZH 037	OZA446-E2	1855
OZH 038	OZA527-E12	0220
OZH 039	OZA572-E12	0273
OZH 040	OZA446-E6	1861
OZH 041	OZA527-E10	0263
OZH 042	OZA527-E6	0463
OZH 043	OZA572-E1	0283
OZH 044	OZA446-E11	1898
OZH 045	OZA448-E44	0293
OZH 046	OZA446-E16	1859
OZH 047	OZA446-E15	1848
OZH 048	OZA445-E3	1860
OZH 049	OZA114-A1	1856
OZH 050	OZA33-D8	1867
OZH 051	OZA446-E13	1826
OZH 052	OZA446-E18	1887
OZH 053	OZA527-E9	0498
OZH 054	OZA448-E13	1893
OZH 055	OZA527-E5	0253
OZH 056	OZA527-E7	0213
OZH 057	OZA527-E8	0284
OZH 058	OZA236-R1	0147
OZH 058	OZA55-R1	1878
OZH 059	OZA33-D5	0199
OZH 059	OZA89-D1	1890
OZH 062	OZA527-E4	0218
OZH 064	OZA527-E19	0296
OZH 066	OZA446-E48	0280
OZH 069	OZA447-E14	0129
OZH 070	OZA447-E16	0259
OZH 074	OZA527-E15	0298
OZH 075	OZA527-E28	0477
OZH 076	OZA253-F6	0122
OZH 079	OZA527-E17	0445
OZH 083	OZA55-R4	0145
OZH 084	OZA112-A1	0146

Рекомендационный перечень

GENUINE	NTK	ORDER
BERU		
OZH 086	OZA448-E31	0151
OZH 087	OZA83-R1	0156
OZH 088	OZA112-A3	0157
OZH 092	OZA83-R2	0167
OZH 094	OZA527-E18	0430
OZH 095	OZA73-F1	0177
OZH 096	OZA83-R3	0178
OZH 098	OZA448-E29	0182
OZH 099	OZA447-E13	0183
OZH 100	OZA186-F5	0188
OZH 101	OZA83-R4	0189
OZH 103	OZA446-E43	0194
OZH 104	OZA527-E16	0434
OZH 107	OZA446-E57	0472
OZH 108	OZA236-R2	0158
OZH 109	OZA311-R1	0191
OZH 118	OZA334-A1	0223
OZH 120	OZA245-H1	0169
OZH 121	OZA245-H2	0180
OZH 122	OZA333-H5	0148
OZH 123	OZA333-H26	0299
OZH 125	OZA311-R2	0126
OZH 127	OZA447-E17	0270
OZH 130	OZA83-VN1	0124
OZH 131	OZA446-E52	0226
OZU 003	OZA401-E4	1822
OZU 004	OZA401-E57	0153
OZU 005	OZA401-E6	1882
OZU 006	OZA65-A2	1889
OZU 010	OZA401-E50	0131
OZU 012	OZA401-E55	0143
OZU 014	OZA401-E56	0154
OZU 015	OZA401-E58	0166
OZU 021	OZA25-F12	0198
OZU 022	OZA401-E2	1802
OZU 024	OZA401-E51	0142
OZU 025	OZA428-E1	1807
BMW		
11781 247 406	OZA447-E28	0427
11781 247 475	OZA572-E6	1777
11781 406 981	OTA7N-5D2	1975
11781 427 884	OTA7H-5A1	0486
11781 433 071	OTA7N-5D1	1974
11781 433 159	OZA572-E14	0408
11781 433 940	OZA447-E29	0438
11781 437 943	OTA7N-5D3	1991
11781 720 536	OZA572-E2	0252
11781 720 537	OZA527-E27	0466
11781 721 125	OZA572-E3	0264
11781 726 321	OZA572-E4	0295

GENUINE	NTK	ORDER
BMW		
11781 730 005	OZA572-E2	0252
11781 730 007	OZA447-E10	0138
11781 730 025	OTA7H-3A1	1932
11781 734 393	OZA572-E8	0209
11781 734 796	OZA572-E12	0273
11781 735 132	OTA7N-5B1	1973
11781 735 499	OZA572-E5	0242
11781 735 710	OZA572-E4	0295
11781 738 282	OTA7H-3A2	1943
11781 742 050	OZA447-E27	0416
11781 748 762	OTA7N-5C1	1963
7 530 285	OZA600-BM5	1846
7 530 287	OZA600-BM2	1845
7 537 995	OZA600-BM7	1847
BOSCH		
0258 001 025	OZA401-E2	1802
0258 001 026	OZA401-E2	1802
0258 001 027	OZA401-E2	1802
0258 001 035	OZA401-E50	0131
0258 001 043	OZA401-E2	1802
0258 001 051	OZA401-E2	1802
0258 001 052	OZA401-E2	1802
0258 002 014	OZA401-E6	1882
0258 002 035	OZA401-E2	1802
0258 002 040	OZA401-E2	1802
0258 002 041	OZA401-E2	1802
0258 002 053	OZA401-E63	0207
0258 002 053	OZA401-E66	0406
0258 002 053	OZA401-E67	0417
0258 002 053	OZA401-E68	0428
0258 003 004	OZA446-E11	1898
0258 003 006	OZA446-E2	1855
0258 003 009	OZA446-E1	1833
0258 003 014	OZA446-E2	1855
0258 003 015	OZA446-E13	1826
0258 003 017	OZA446-E6	1861
0258 003 019	OZA446-E2	1855
0258 003 021	OZA446-E3	1866
0258 003 027	OZA446-E49	0291
0258 003 028	OZA446-E5	1838
0258 003 032	OZA446-E2	1855
0258 003 036	OZA446-E15	1848
0258 003 040	OZA445-E6	0258
0258 003 046	OZA446-E48	0280
0258 003 051	OZA448-E39	0210
0258 003 052	OZA527-E27	0466
0258 003 057	OZA446-E16	1859
0258 003 060	OZA446-E49	0291
0258 003 061	OZA446-E4	1877
0258 003 064	OZA572-E2	0252

Рекомендационный перечень

GENUINE	NTK	ORDER
BOSCH		
0258 003 068	OZA447-E10	0138
0258 003 069	OZA572-E3	0264
0258 003 074	OZA527-E2	0265
0258 003 075	OZA446-E44	0162
0258 003 078	OZA527-E22	0274
0258 003 083	OZA445-E6	0258
0258 003 085	OZA445-E6	0258
0258 003 086	OZA446-E8	1827
0258 003 090	OZA446-E2	1855
0258 003 095	OZA445-E7	0269
0258 003 096	OZA446-E46	0139
0258 003 101	OZA446-E5	1838
0258 003 108	OZA572-E4	0295
0258 003 114	OZA445-E4	1850
0258 003 115	OZA572-E4	0295
0258 003 118	OZA527-E28	0477
0258 003 119	OZA446-E49	0291
0258 003 121	OZA216-D3	0125
0258 003 123	OZA448-E48	0239
0258 003 134	OZA446-E13	1826
0258 003 139	OZA446-E6	1861
0258 003 141	OZA446-E3	1866
0258 003 146	OZA446-E14	1837
0258 003 156	OZA446-E7	1872
0258 003 157	OZA446-E7	1872
0258 003 164	OZA446-E11	1898
0258 003 165	OZA446-E42	0150
0258 003 166	OZA446-E42	0150
0258 003 175	OZA446-E2	1855
0258 003 181	OZA446-E42	0150
0258 003 189	OZA446-E8	1827
0258 003 193	OZA527-E8	0284
0258 003 194	OZA446-E11	1898
0258 003 197	OZA384-E40	0484
0258 003 198	OZA384-E40	0484
0258 003 203	OZA527-E3	0201
0258 003 207	OZA446-E52	0226
0258 003 208	OZA446-E52	0226
0258 003 211	OZA446-E51	0215
0258 003 213	OZA446-E53	0237
0258 003 215	OZA572-E8	0209
0258 003 219	OZA572-E5	0242
0258 003 220	OZA572-E8	0209
0258 003 222	OZA527-E4	0218
0258 003 229	OZA527-E9	0498
0258 003 231	OZA572-E8	0209
0258 003 234	OZA446-E2	1855
0258 003 235	OZA446-E2	1855
0258 003 239	OZA527-E12	0220
0258 003 241	OZA445-E7	0269
0258 003 244	OZA572-E8	0209

GENUINE	NTK	ORDER
BOSCH		
0258 003 247	OZA445-E2	1810
0258 003 248	OZA445-E2	1810
0258 003 249	OZA446-E55	0450
0258 003 250	OZA446-E55	0450
0258 003 254	OZA445-E7	0269
0258 003 256	OZA446-E45	0155
0258 003 259	OZA448-E12	1865
0258 003 261	OZA572-E12	0273
0258 003 265	OZA572-E1	0283
0258 003 266	OZA572-E1	0283
0258 003 267	OZA572-E13	0254
0258 003 268	OZA572-E13	0254
0258 003 279	OZA446-E12	1805
0258 003 280	OZA446-E12	1805
0258 003 281	OZA446-E50	0204
0258 003 282	OZA446-E50	0204
0258 003 291	OZA448-E12	1865
0258 003 292	OZA216-D3	0125
0258 003 300	OZA446-E6	1861
0258 003 301	OZA527-E5	0253
0258 003 303	OZA527-E14	0455
0258 003 311	OZA446-E45	0155
0258 003 312	OZA446-E45	0155
0258 003 313	OZA446-E2	1855
0258 003 320	OZA527-E10	0263
0258 003 321	OZA527-E10	0263
0258 003 324	OZA527-E6	0463
0258 003 325	OZA527-E6	0463
0258 003 333	OZA527-E18	0430
0258 003 339	OZA448-E12	1865
0258 003 340	OZA448-E41	0260
0258 003 342	OZA448-E12	1865
0258 003 343	OZA448-E42	0271
0258 003 357	OZA572-E8	0209
0258 003 360	OZA448-E56	0481
0258 003 383	OZA502-E35	0447
0258 003 383	OZA502-E36	0458
0258 003 396	OZA446-E50	0204
0258 003 420	OZA446-E45	0155
0258 003 423	OZA448-E55	0470
0258 003 437	OZA527-E14	0455
0258 003 439	OZA572-E1	0283
0258 003 446	OZA446-E41	0128
0258 003 447	OZA446-E40	0193
0258 003 448	OZA446-E40	0193
0258 003 454	OZA447-E31	0460
0258 003 455	OZA447-E31	0460
0258 003 466	OZA527-E7	0213
0258 003 477	OZA447-E27	0416
0258 003 478	OZA447-E30	0449
0258 003 479	OZA447-E30	0449

Рекомендационный перечень

GENUINE	NTK	ORDER
BOSCH		
0258 003 485	OZA448-E48	0239
0258 003 486	OZA448-E44	0293
0258 003 503	OZA446-E58	0483
0258 003 508	OZA446-E11	1898
0258 003 510	OZA446-E12	1805
0258 003 511	OZA446-E12	1805
0258 003 513	OZA527-E13	0285
0258 003 518	OZA447-E14	0129
0258 003 519	OZA447-E14	0129
0258 003 522	OZA572-E6	1777
0258 003 524	OZA446-E43	0194
0258 003 542	OZA447-E16	0259
0258 003 543	OZA447-E16	0259
0258 003 544	OZA448-E31	0151
0258 003 545	OZA448-E31	0151
0258 003 546	OZA572-E9	0423
0258 003 547	OZA572-E9	0423
0258 003 548	OZA572-E11	0251
0258 003 556	OZA448-E52	0437
0258 003 559	OZA447-E28	0427
0258 003 569	OZA446-E18	1887
0258 003 570	OZA446-E18	1887
0258 003 575	OZA572-E11	0251
0258 003 576	OZA572-E11	0251
0258 003 578	OZA527-E4	0218
0258 003 579	OZA527-E7	0213
0258 003 586	OZA572-E11	0251
0258 003 587	OZA572-E11	0251
0258 003 604	OZA572-E11	0251
0258 003 605	OZA572-E9	0423
0258 003 611	OZA447-E36	1950
0258 003 612	OZA447-E36	1950
0258 003 627	OZA527-E19	0296
0258 003 630	OZA447-E36	1950
0258 003 631	OZA447-E36	1950
0258 003 632	OZA572-E10	0275
0258 003 638	OZA448-E38	0160
0258 003 644	OZA448-E43	0282
0258 003 646	OZA447-E31	0460
0258 003 667	OZA527-E15	0298
0258 003 668	OZA527-E16	0434
0258 003 669	OZA527-E17	0445
0258 003 670	OZA448-E56	0481
0258 003 671	OZA527-E29	0488
0258 003 694	OZA447-E31	0460
0258 003 696	OZA447-E31	0460
0258 003 713	OZA89-D1	1890
0258 003 714	OZA448-E44	0293
0258 003 715	OZA446-E57	0472
0258 003 716	OZA448-E57	0492
0258 003 719	OZA448-E56	0481

GENUINE	NTK	ORDER
BOSCH		
0258 003 734	OZA447-E31	0460
0258 003 738	OZA447-E31	0460
0258 003 740	OZA447-E25	0494
0258 003 741	OZA447-E25	0494
0258 003 745	OZA447-E13	0183
0258 003 755	OZA447-E30	0449
0258 003 756	OZA447-E30	0449
0258 003 757	OZA447-E35	0493
0258 003 759	OZA448-E31	0151
0258 003 760	OZA448-E31	0151
0258 003 770	OZA448-E37	0152
0258 003 772	OZA527-E7	0213
0258 003 779	OZA33-D8	1867
0258 003 798	OZA447-E21	0216
0258 003 805	OZA527-E19	0296
0258 003 810	OZA572-E14	0408
0258 003 842	OZA447-E31	0460
0258 003 843	OZA447-E31	0460
0258 003 846	OZA447-E32	0471
0258 003 847	OZA447-E32	0471
0258 003 855	OZA448-E54	0459
0258 003 856	OZA448-E54	0459
0258 003 857	OZA447-E30	0449
0258 003 858	OZA447-E30	0449
0258 003 862	OZA447-E22	0227
0258 003 866	OZA572-E11	0251
0258 003 870	OZA448-E45	0206
0258 003 913	OZA446-E46	0139
0258 003 915	OZA446-E13	1826
0258 003 925	OZA446-E14	1837
0258 003 931	OZA446-E2	1855
0258 003 936	OZA446-E15	1848
0258 003 957	OZA446-E16	1859
0258 003 973	OZA446-E15	1848
0258 003 979	OZA445-E3	1860
0258 003 995	OZA445-E7	0269
0258 005 001	OZA448-E29	0182
0258 005 002	OZA448-E29	0182
0258 005 007	OZA447-E26	0405
0258 005 049	OZA447-E31	0460
0258 005 055	OZA448-E49	0404
0258 005 066	OZA447-E31	0460
0258 005 068	OZA447-E31	0460
0258 005 070	OZA448-E47	0228
0258 005 075	OZA447-E31	0460
0258 005 079	OZA447-E17	0270
0258 005 081	OZA447-E32	0471
0258 005 082	OZA447-E32	0471
0258 005 083	OZA448-E29	0182
0258 005 088	OZA447-E34	0482
0258 005 089	OZA447-E34	0482

Рекомендационный перечень

GENUINE	NTK	ORDER
BOSCH		
0258 005 100	OZA447-E32	0471
0258 005 109	OZA447-E29	0438
0258 005 110	OZA448-E53	0448
0258 005 113	OZA447-E18	0281
0258 005 115	OZA448-E51	0426
0258 005 116	OZA448-E51	0426
0258 005 117	OZA447-E32	0471
0258 005 119	OZA447-E32	0471
0258 005 135	OZA448-E50	0415
0258 005 158	OZA447-E31	0460
0258 005 160	OZA447-E35	0493
0258 005 187	OZA447-E32	0471
0258 005 254	OZA502-E34	0436
0258 005 293	OZA448-E58	1909
0258 005 294	OZA448-E58	1909
0258 006 021	OZA527-E24	0287
0258 006 190	OZA527-E24	0287
0986 258 009	OZA446-E56	0461
CHRYSLER		
MD 119 210	OZA401-E63	0207
MD 128 262	OZA401-E54	0186
MD 148 738	OZA428-E3	0121
MD 150 609	OZA428-E2	0197
MD 183 145	OZA502-E34	0436
MD 183 399	OZA502-E35	0447
CITROEN		
1618 72	OZA495-PG3	1853
1628 6R	OZA527-E15	0298
1628 6S	OZA527-E16	0434
1628 6W	OZA527-E17	0445
1628 7S	OZA527-E29	0488
1628 9T	OZA448-E56	0481
1628 9W	OZA448-E57	0492
1628 A4	OZA446-E48	0280
1628 J4	OZA527-E2	0265
1628 KN	OZA495-PG2	1852
1628 KP	OZA341-PG7	1815
1628 L4	OZA527-E22	0274
1628 LP	OZA334-PG1	1790
1628 NY	OZA341-PG5	1813
1628 PW	LZA06-U1	1840
1628 PX	OZA538-PG1	1818
1628 QY	OZA341-PG6	1814
1628 T2	OZA527-E3	0201
1628 TG	OZA538-PG2	1819
1628 TH	OZA341-PG8	1816
96 027 244	OZA527-E2	0265
96 036 827	OZA527-E22	0274
96 121 278 17	OZA527-E12	0220

GENUINE	NTK	ORDER
CITROEN		
96 127 346	OZA527-E12	0220
96 138 608	OZA527-E3	0201
96 229 969	OZA527-E15	0298
96 229 970	OZA527-E16	0434
96 229 971	OZA527-E17	0445
96 230 002	OZA527-E29	0488
96 284 479	OZA448-E57	0492
96 284 479 80	OZA448-E57	0492
96 284 482	OZA448-E56	0481
96 366 522 80	OZA334-PG1	1790
96 369 209 80	LZA06-U1	1840
96 369 683 80	OZA341-PG5	1813
96 369 684 80	OZA341-PG6	1814
96 369 685 80	OZA341-PG7	1815
96 369 687 80	OZA495-PG2	1852
96 369 688 80	OZA495-PG3	1853
96 393 054 80	OZA538-PG1	1818
96 424 707 80	OZA538-PG2	1819
96 424 708 80	OZA341-PG8	1816
DAEWOO		
251 060 73	OZA401-E6	1882
965 079 86	OZA341-W2	0440
FACET		
10.7020	OZA448-E37	0152
10.7021	OZA527-E19	0296
10.7022	OZA527-E7	0213
10.7024	OZA448-E56	0481
10.7025	OZA446-E50	0204
10.7026	OZA446-E2	1855
10.7030	OZA446-E49	0291
10.7031	OZA446-E12	1805
10.7032	OZA572-E3	0264
10.7034	OZA527-E14	0455
10.7036	OZA527-E12	0220
10.7041	OZA527-E5	0253
10.7042	OZA446-E42	0150
10.7043	OZA445-E2	1810
10.7044	OZA445-E4	1850
10.7045	OZA446-E15	1848
10.7046	OZA65-A2	1889
10.7047	OZA401-E2	1802
10.7048	OZA446-E18	1887
10.7049	OZA572-E9	0423
10.7056	OZA572-E13	0254
10.7057	OZA527-E9	0498
10.7062	OZA446-E57	0472
10.7069	OZA527-E29	0488
10.7070	OZA448-E13	1893
10.7072	OZA401-E6	1882

Рекомендационный перечень

GENUINE	NTK	ORDER
FACET		
10.7075	OZA334-A3	0245
10.7076	OZA446-E3	1866
10.7087	OZA447-E36	1950
10.7089	OZA447-E26	0405
10.7096	OZA334-A2	0234
10.7097	OZA448-E50	0415
10.7136	OZA334-SZ4	0418
10.7145	OZA572-E10	0275
10.7148	OZA447-E14	0129
10.7159	OZA531-GM2	1863
10.7163	OZA447-E32	0471
10.7171	OZA447-E17	0270
10.7178	OZA510-AU1	1782
10.7184	OZA572-E4	0295
10.7188	OZA572-E5	0242
10.7197	OZA114-A1	1856
10.7199	OZA74-F2	0433
10.7203	OZA74-F1	0401
10.7205	OZA112-A3	0157
10.7211	OZA112-A4	0236
10.7213	OZA341-A1	1798
10.7214	OZA334-A1	0223
10.7247	OZA25-KH1	1940
10.7263	OZA73-F1	0177
10.7264	OZA236-R1	0147
10.7265	OZA446-E6	1861
10.7268	OZA83-R1	0156
10.7269	OZA448-E43	0282
10.7279	OZA55-R3	0134
10.7282	OZA277-R2	0468
10.7284	OZA311-R2	0126
10.7300	OZA446-E43	0194
10.7301	OZA448-E31	0151
10.7304	OZA447-E25	0494
10.7307	OZA112-A2	0225
10.7320	OZA519-D1	0244
10.7322	OZA381-D1	1820
10.7327	OZA446-E45	0155
10.7336	OZA448-E49	0404
10.7345	OZA446-E40	0193
10.7352	OZA447-E31	0460
10.7362	OZA334-AU1	0474
10.7364	OZA85-M1	0165
10.7366	OZA401-E63	0207
10.7383	OZA401-E51	0142
10.7389	OZA448-E53	0448
10.7403	OZA448-E57	0492
10.7405	OZA527-E24	0287
10.7413	OZA448-E54	0459
10.7428	OZA447-E35	0493
10.7441	OZA112-A1	0146

GENUINE	NTK	ORDER
FACET		
10.7589	OZA446-E44	0162
10.7670	OZA112-A6	1759
10.7671	OZA112-A7	1760
10.7685	OZA488-D2	1757
10.7692	OZA583-GM2	1754
10.7697	OZA575-GM1	1895
10.7785	OZA446-E55	0450
10.7898	OZA573-E1	0286
10.7943	OZA532-A4	1786
10.7945	OZA534-A2	1764
10.7946	OZA532-A5	1792
FERRARI		
12 15 15	OZA446-E1	1833
14 25 14	OZA527-E4	0218
FIAT		
46 407 316	OZA112-A2	0225
46 408 449	OZA446-E18	1887
46 417 969	OZA527-E7	0213
46 418 568	OZA527-E19	0296
46 418 813	OZA112-A3	0157
46 419 222	OZA114-A1	1856
46 422 649	OZA448-E13	1893
46 424 723	OZA527-E7	0213
46 447 841	OZA112-A4	0236
46 449 401	OZA527-E19	0296
46 462 006	OZA527-E24	0287
46 481 457	OZA112-A6	1759
46 481 458	OZA112-A7	1760
46 521 170	OZA334-A1	0223
46 523 129	OZA334-A2	0234
46 529 385	OZA334-A3	0245
46 545 432	OZA341-A1	1798
46 552 313	OZA532-A1	0478
46 750 249	OZA532-A2	0489
46 760 867	OZA532-A3	0409
46 774 531	OZA534-A1	1762
46 774 534	OZA534-A3	1800
46 786 046	OZA534-A2	1764
46 786 047	OZA532-A5	1792
46 807 454	OZA532-A7	1796
46 811 313	OZA532-A4	1786
46 823 880	OZA532-A9	1793
55 184 545	OZA532-A10	1794
60 507 690	OZA446-E4	1877
60 537 650	OZA446-E49	0291
60 562 536	OZA527-E4	0218
60 567 759	OZA446-E5	1838
60 578 768	OZA527-E5	0253

Рекомендационный перечень

GENUINE	NTK	ORDER
FIAT		
60 805 428	OZA446-E4	1877
60 808 457	OZA446-E5	1838
60 809 012	OZA446-E1	1833
60 810 814	OZA527-E7	0213
76 193 03	OZA446-E4	1877
76 542 21	OZA446-E5	1838
76 740 48	OZA445-E6	0258
77 067 54	OZA65-A2	1889
77 513 08	OZA112-A1	0146
77 859 73	OZA446-E18	1887
96 284 482	OZA448-E56	0481
96 284 482 80	OZA448-E56	0481
FORD		
1001 702	OZA216-D2	0190
1010 620	OZA448-E44	0293
1013 764	OZA89-D1	1890
1025 958	OZA216-D3	0125
1035 595	OZA381-D1	1820
1053 108	OZA519-D1	0244
1640 552	OZA446-E46	0139
3000 923	OZA488-D2	1757
3010 660	OZA488-D1	0403
3017 524	OZA381-D2	0451
3721 930	OZA381-D3	0462
6169 693	OZA448-E39	0210
6199 647	OZA527-E28	0477
6847 908	OZA33-D8	1867
6847 910	OZA33-D5	0199
6847 911	OZA89-D1	1890
6847 912	OZA448-E12	1865
6847 914	OZA448-E42	0271
6847 916	OZA448-E41	0260
7011 190	OZA448-E55	0470
7089 574	OZA89-D2	0135
7126 155	OZA448-E48	0239
7126 156	OZA448-E44	0293
7325 143	OZA447-E36	1950
87AB 9F472 AA	OZA448-E39	0210
89BB 9F472 AA	OZA527-E28	0477
89FB 9F472 AC	OZA448-E12	1865
90BB 9F472 AB	OZA216-D3	0125
93AB 9F472 AA	OZA33-D8	1867
93BB 9F472 AA	OZA89-D1	1890
93FB 9F472 AA	OZA448-E12	1865
93GB 9F472 AA	OZA448-E12	1865
93GB 9F472 BA	OZA448-E42	0271
93GB 9F472 DA	OZA448-E55	0470
93VB 9F472 AA	OZA448-E41	0260
95FB 9F472 CB	OZA448-E48	0239
95FB 9F472 DB	OZA448-E44	0293

GENUINE	NTK	ORDER
FORD		
95VW 9F472 CB	OZA447-E36	1950
95VW 9F472 FA	OZA447-E31	0460
96FB 9F472 DA	OZA448-E44	0293
98AB 9F472 BB	OZA519-D1	0244
98AB 9G444 BB	OZA381-D1	1820
XC2F 9F472 AA	OZA488-D1	0403
XC2F 9F472 BA	OZA488-D2	1757
XR3F 9G444 AA	OZA381-D2	0451
XR3F 9G444 BA	OZA381-D3	0462
GM		
24 133 391	OZA401-E6	1882
25 106 073	OZA401-E6	1882
HELLA		
6PA 009 165-001	OZA401-E6	1882
6PA 009 165-011	OZA448-E44	0293
6PA 009 165-021	OZA446-E2	1855
6PA 009 165-041	OZA527-E15	0298
6PA 009 165-051	OZA527-E7	0213
6PA 009 165-061	OZA446-E8	1827
6PA 009 165-071	OZA401-E2	1802
6PA 009 165-081	OZA527-E4	0218
6PA 009 165-091	OZA33-D8	1867
6PA 009 165-101	OZA572-E8	0209
6PA 009 165-111	OZA236-R1	0147
6PA 009 165-131	OZA445-E4	1850
6PA 009 165-141	OZA527-E8	0284
6PA 009 165-151	OZA572-E1	0283
6PA 009 165-161	OZA447-E30	0449
6PA 009 165-171	OZA527-E2	0265
6PA 009 165-181	OZA446-E45	0155
6PA 009 165-191	OZA446-E42	0150
6PA 009 165-201	OZA446-E6	1861
6PA 009 165-211	OZA527-E12	0220
6PA 009 165-221	OZA447-E14	0129
6PA 009 165-231	OZA527-E3	0201
6PA 009 165-241	OZA446-E15	1848
6PA 009 165-251	OZA446-E57	0472
6PA 009 165-261	OZA527-E13	0285
6PA 009 165-271	OZA446-E49	0291
6PA 009 165-291	OZA446-E46	0139
6PA 009 165-301	OZA401-E50	0131
6PA 009 165-311	OZA446-E7	1872
6PA 009 165-321	OZA448-E31	0151
6PA 009 165-331	OZA401-E4	1822
6PA 009 165-341	OZA527-E17	0445
6PA 009 165-351	OZA446-E40	0193
6PA 009 165-361	OZA445-E3	1860
6PA 009 165-371	OZA447-E16	0259
6PA 009 165-381	OZA445-E6	0258

Рекомендационный перечень

GENUINE	NTK	ORDER
HELLA		
6PA 009 165-391	OZA401-E55	0143
6PA 009 165-401	OZA446-E14	1837
6PA 009 165-411	OZA527-E16	0434
6PA 009 165-421	OZA446-E16	1859
6PA 009 165-431	OZA446-E3	1866
6PA 009 165-441	OZA527-E19	0296
6PA 009 165-451	OZA572-E6	1777
6PA 009 165-461	OZA112-A1	0146
6PA 009 165-471	OZA55-R4	0145
6PA 009 165-481	OZA428-E1	1807
6PA 009 165-491	OZA572-E12	0273
6PA 009 165-511	OZA446-E11	1898
6PA 009 165-521	OZA83-R4	0189
6PA 009 165-531	OZA445-E2	1810
6PA 009 165-541	OZA527-E22	0274
6PA 009 165-551	OZA572-E11	0251
6PA 009 165-561	OZA89-D1	1890
6PA 009 165-571	OZA216-D3	0125
6PA 009 165-581	OZA446-E13	1826
6PA 009 165-591	OZA572-E4	0295
6PA 009 165-601	OZA401-E51	0142
6PA 009 165-621	OZA446-E50	0204
6PA 009 165-631	OZA401-E57	0153
6PA 009 165-641	OZA447-E13	0183
6PA 009 165-651	OZA527-E9	0498
6PA 009 165-671	OZA236-R2	0158
6PA 009 166-001	OZA186-F5	0188
6PA 009 166-011	OZA527-E10	0263
6PA 009 166-031	OZA448-E31	0151
6PA 009 166-051	OZA447-E10	0138
6PA 009 166-061	OZA527-E27	0466
6PA 009 166-071	OZA25-F12	0198
6PA 009 166-081	OZA446-E48	0280
6PA 009 166-091	OZA527-E28	0477
6PA 009 166-101	OZA65-A2	1889
6PA 009 166-111	OZA527-E5	0253
6PA 009 166-121	OZA446-E51	0215
6PA 009 166-141	OZA448-E29	0182
6PA 009 166-151	OZA112-A3	0157
6PA 009 166-161	OZA401-E56	0154
6PA 009 166-171	OZA446-E18	1887
6PA 009 166-191	OZA253-F6	0122
6PA 009 166-201	OZA73-F1	0177
6PA 009 166-211	OZA527-E18	0430
6PA 009 166-221	OZA448-E45	0206
6PA 009 166-231	OZA448-E38	0160
6PA 009 166-241	OZA311-R1	0191
6PA 009 166-251	OZA448-E13	1893
6PA 009 166-261	OZA83-R1	0156
6PA 009 166-271	OZA446-E43	0194
6PA 009 166-281	OZA401-E58	0166

GENUINE	NTK	ORDER
HELLA		
6PA 009 166-311	OZA448-E48	0239
6PA 009 166-321	OZA83-R2	0167
6PA 009 166-331	OZA83-R3	0178
6PA 009 166-421	OTA7H-3A1	1932
6PA 009 166-441	OTA7H-3A2	1943
6PA 009 166-451	OTA7N-5C1	1963
6PA 009 166-461	OTA7H-5A1	0486
6PA 009 166-471	OTA7L-3C3	0442
6PA 009 166-481	OTA7L-3C4	0431
6PA 009 166-491	OTA7H-3C1	1954
6PA 009 166-501	OZA334-SZ1	0485
6PA 009 166-511	OZA334-SZ4	0418
6PA 009 166-521	OTA7N-5A1	1920
6PA 009 166-531	OTA7N-5A2	1938
6PA 009 166-541	OTA7N-5D1	1974
6PA 009 166-551	OTA7H-3C2	0420
6PA 009 166-561	OZA334-SZ3	0407
6PA 009 166-571	OZA334-SZ2	0496
HLS 001	OZA401-E6	1882
HLS 002	OZA448-E44	0293
HLS 003	OZA446-E2	1855
HLS 005	OZA527-E15	0298
HLS 006	OZA527-E7	0213
HLS 007	OZA446-E8	1827
HLS 008	OZA401-E2	1802
HLS 009	OZA527-E4	0218
HLS 010	OZA33-D8	1867
HLS 011	OZA572-E8	0209
HLS 012	OZA236-R1	0147
HLS 013	OZA445-E4	1850
HLS 014	OZA527-E8	0284
HLS 015	OZA572-E1	0283
HLS 016	OZA447-E30	0449
HLS 017	OZA527-E2	0265
HLS 018	OZA446-E45	0155
HLS 019	OZA446-E42	0150
HLS 020	OZA446-E6	1861
HLS 021	OZA527-E12	0220
HLS 022	OZA447-E14	0129
HLS 023	OZA527-E3	0201
HLS 024	OZA446-E15	1848
HLS 025	OZA446-E57	0472
HLS 026	OZA527-E13	0285
HLS 027	OZA446-E49	0291
HLS 029	OZA446-E46	0139
HLS 030	OZA401-E50	0131
HLS 031	OZA446-E7	1872
HLS 032	OZA448-E31	0151
HLS 033	OZA401-E4	1822
HLS 034	OZA527-E17	0445
HLS 035	OZA446-E40	0193

Рекомендационный перечень

GENUINE	NTK	ORDER
HELLA		
HLS 036	OZA445-E3	1860
HLS 037	OZA447-E16	0259
HLS 038	OZA445-E6	0258
HLS 039	OZA401-E55	0143
HLS 040	OZA446-E14	1837
HLS 041	OZA527-E16	0434
HLS 042	OZA446-E16	1859
HLS 043	OZA446-E3	1866
HLS 044	OZA527-E19	0296
HLS 045	OZA572-E6	1777
HLS 046	OZA112-A1	0146
HLS 047	OZA55-R4	0145
HLS 048	OZA428-E1	1807
HLS 049	OZA572-E12	0273
HLS 051	OZA446-E11	1898
HLS 052	OZA83-R4	0189
HLS 053	OZA445-E2	1810
HLS 054	OZA527-E22	0274
HLS 055	OZA572-E11	0251
HLS 056	OZA89-D1	1890
HLS 057	OZA216-D3	0125
HLS 058	OZA446-E13	1826
HLS 059	OZA572-E4	0295
HLS 060	OZA401-E51	0142
HLS 062	OZA446-E50	0204
HLS 063	OZA401-E57	0153
HLS 064	OZA447-E13	0183
HLS 065	OZA527-E9	0498
HLS 067	OZA236-R2	0158
HLS 068	OZA186-F5	0188
HLS 069	OZA527-E10	0263
HLS 071	OZA448-E31	0151
HLS 073	OZA447-E10	0138
HLS 074	OZA527-E27	0466
HLS 075	OZA25-F12	0198
HLS 076	OZA446-E48	0280
HLS 077	OZA527-E28	0477
HLS 078	OZA65-A2	1889
HLS 079	OZA527-E5	0253
HLS 080	OZA446-E51	0215
HLS 082	OZA448-E29	0182
HLS 083	OZA112-A3	0157
HLS 084	OZA401-E56	0154
HLS 085	OZA446-E18	1887
HLS 087	OZA253-F6	0122
HLS 088	OZA73-F1	0177
HLS 089	OZA527-E18	0430
HLS 090	OZA448-E45	0206
HLS 091	OZA448-E38	0160
HLS 092	OZA311-R1	0191
HLS 093	OZA448-E13	1893

GENUINE	NTK	ORDER
HELLA		
HLS 094	OZA83-R1	0156
HLS 095	OZA446-E43	0194
HLS 096	OZA401-E58	0166
HLS 099	OZA448-E48	0239
HLS 100	OZA83-R2	0167
HLS 101	OZA83-R3	0178
HLS 107	OTA7H-3A1	1932
HLS 109	OTA7H-3A2	1943
HLS 111	OTA7H-5A1	0486
HLS 112	OTA7L-3C3	0442
HLS 113	OTA7L-3C4	0431
HLS 114	OTA7H-3C1	1954
HLS 115	OZA334-SZ1	0485
HLS 116	OZA334-SZ4	0418
HLS 117	OTA7N-5A1	1920
HLS 118	OTA7N-5A2	1938
HLS 120	OTA7H-3C2	0420
HLS 121	OZA334-SZ3	0407
HLS 122	OZA334-SZ2	0496
HJS		
9201 7721	OZA445-E7	0269
9201 7759	OZA448-E43	0282
9201 7766	OTA7N-5D1	1974
9201 7768	OZA447-E26	0405
9201 7769	OZA448-E43	0282
9201 7774	OZA527-E7	0213
9201 7775	OZA527-E19	0296
9201 7782	OZA446-E40	0193
9201 7788	OZA448-E45	0206
9201 7789	OZA527-E4	0218
9201 7790	OZA572-E12	0273
9201 7793	OZA572-E10	0275
9201 7794	OZA446-E45	0155
9201 7795	OZA447-E35	0493
9201 7797	OZA447-E18	0281
9201 7799	OZA448-E51	0426
9201 7800	OZA446-E15	1848
9201 7801	OZA445-E3	1860
9201 7802	OZA448-E31	0151
9201 7803	OZA445-E4	1850
9201 7804	OZA446-E42	0150
9201 7805	OZA446-E11	1898
9201 7806	OZA446-E16	1859
9201 7807	OZA401-E2	1802
9201 7810	OZA572-E9	0423
9201 7812	OZA446-E12	1805
9201 7813	OZA446-E6	1861
9201 7814	OZA446-E3	1866
9201 7816	OZA401-E6	1882
9201 7818	OZA401-E4	1822

Рекомендационный перечень

GENUINE	NTK	ORDER
HJS		
9201 7820	OZA572-E13	0254
9201 7821	OZA572-E1	0283
9201 7822	OZA446-E53	0237
9201 7823	OZA445-E2	1810
9201 7826	OZA401-E2	1802
9201 7827	OZA446-E8	1827
9201 7829	OZA446-E8	1827
9201 7830	OZA572-E9	0423
9201 7831	OZA401-E2	1802
9201 7832	OZA446-E11	1898
9201 7833	OZA446-E48	0280
9201 7834	OZA527-E2	0265
9201 7835	OZA527-E22	0274
9201 7836	OZA527-E22	0274
9201 7838	OZA401-E55	0143
9201 7840	OZA25-F3	0176
9201 7841	OZA25-F12	0198
9201 7844	OZA446-E42	0150
9201 7846	OZA401-E63	0207
9201 7856	OZA401-E54	0186
9201 7859	OZA447-E30	0449
9201 7861	OZA401-E2	1802
9201 7868	OZA401-E49	0120
9201 7872	OZA446-E4	1877
9201 7874	OZA384-E39	0473
9201 7876	OZA527-E27	0466
9201 7880	OZA572-E3	0264
9201 7881	OZA572-E3	0264
9201 7882	OZA572-E2	0252
9201 7883	OZA447-E10	0138
9201 7884	OTA7H-3A1	1932
9201 7885	OZA572-E8	0209
9201 7886	OZA572-E5	0242
9201 7890	OZA527-E17	0445
9201 7890	OZA527-E3	0201
9201 7891	OZA401-E57	0153
9201 7894	OZA401-E56	0154
9201 7901	OZA401-E2	1802
9201 7908	OZA401-E6	1882
9201 7909	OZA401-E56	0154
9201 7910	OZA401-E58	0166
9201 7911	OZA446-E14	1837
9201 7912	OZA446-E13	1826
9201 7915	OZA446-E14	1837
9201 7918	OZA448-E12	1865
9201 7919	OZA446-E46	0139
9201 7920	OZA448-E39	0210
9201 7923	OZA527-E28	0477
9201 7925	OZA448-E55	0470
9201 7932	OZA401-E50	0131
9201 7935	OTD2F-3K1	1907

GENUINE	NTK	ORDER
HJS		
9201 7936	OZA401-E51	0142
9201 7941	OZA446-E1	1833
9201 7942	OZA446-E4	1877
9201 7943	OZA446-E7	1872
9201 7946	OZA448-E12	1865
9201 7947	OZA448-E12	1865
9201 7948	OZA448-E42	0271
9201 7955	OZA446-E2	1855
9201 7956	OZA446-E49	0291
9201 7957	OZA446-E1	1833
9201 7960	OZA572-E8	0209
9201 7961	OZA448-E38	0160
9201 7962	OZA527-E10	0263
9201 7963	OZA527-E13	0285
9201 7963	OZA527-E6	0463
9201 7964	OZA384-E40	0484
9201 7965	OZA446-E3	1866
9201 7966	OZA401-E6	1882
9201 7968	OZA428-E1	1807
9201 7970	OZA527-E12	0220
9201 7971	OZA527-E3	0201
9201 7972	OTA7H-3A2	1943
9201 7974	OZA572-E6	1777
9201 7975	OZA527-E17	0445
9201 7981	OZA447-E17	0270
9201 7982	OTA7N-5C1	1963
9201 7984	OZA448-E44	0293
9201 7985	OTA7H-5A1	0486
9201 7986	OZA447-E28	0427
9201 7987	OZA447-E17	0270
9201 7993	OZA527-E14	0455
9201 7994	OZA447-E16	0259
9201 7995	OZA448-E31	0151
9201 7998	OZA447-E14	0129
9201 9929	OZA446-E49	0291
9201 9930	OZA446-E2	1855
9201 9931	OZA446-E2	1855
9207 0016	OZA401-E6	1882
HONDA		
35531-P1H-E01	OZA502-E28	0425
36531-P1K-E02	OZA333-H4	0137
36531-P1K-E021	OZA333-H4	0137
36531-P1K-E03	OZA333-H26	0299
36531-P45-G012	OZA245-H1	0169
36531-P45-G02	OZA245-H1	0169
36531-P5S-G012	OZA245-H2	0180
36531-P9K-E01	OZA333-H6	0159
36531-P9K-E011	OZA333-H6	0159
36531-P9L-E011	OZA333-H5	0148
36531-P9L-E02	OZA333-H27	0212

Рекомендационный перечень

GENUINE	NTK	ORDER
HONDA		
36531-P9L-E02	OZA333-H5	0148
36531-PDA-E02	OZA501-H17	0266
36531-PDE-E01	OZA421-H1	0255
36531-PDE-E02	OZA569-H1	0499
36531-PE7-662	OZA401-E52	0164
36531-PM8-305	OZA401-E57	0153
36531-PM8-A03	OZA401-E57	0153
36532-P1J-E01	OZA333-H25	0288
36532-P1J-E010-M2	OZA333-H25	0288
36532-PDE-E01	OZA333-H19	0277
36532-PDE-E010-M2	OZA333-H19	0277
36532-PDE-E020 M2	OZA501-H23	0469
HYUNDAI		
39210 22015	OZA446-E56	0461
39210 24520	OZA25-KH3	1969
39210 32520	OZA25-KH1	1940
MD 076 706	OZA401-E66	0406
MD 078 791	OZA401-E67	0417
MD 088 616	OZA401-E68	0428
MD 107 793	OZA401-E68	0428
JAGUAR		
4LS D3J	OTD3J-5B1	0464
70412 A	OTD3J-5B1	0464
DBC 6907	OZA446-E4	1877
LHE 1682 AA	OTD3J-5B1	0464
XC2F 9F472 AA	OZA488-D1	0403
XR3F 9G444 AA	OZA381-D2	0451
XR3F 9G444 BA	OZA381-D3	0462
KIA		
BP03 18861 B	OZA401-E55	0143
LANCIA		
46 452 598	OZA448-E37	0152
46 462 006	OZA527-E24	0287
46 521 170	OZA334-A1	0223
46 523 129	OZA334-A2	0234
60 812 717	OZA527-E7	0213
96 28 448 280	OZA448-E56	0481
96 284 482	OZA448-E56	0481
MAZDA		
B3C7 18861 A	OZA73-F1	0177
B64N 18861	OZA25-F12	0198
B6DC 18861 A	OZA186-F5	0188
BP03 18861 B	OZA401-E55	0143
F201 18861 A	OZA25-F3	0176
FEH1 18861	OZA25-F1	0187
JE08 18861 B	OZA21-F3	0256

GENUINE	NTK	ORDER
MAZDA		
JE50 18861	OZA74-F3	0446
JE50 18861 A	OZA253-F6	0122
JE50 18861 A	OZA74-F2	0433
K802 18861 C	OZA74-F1	0401
KJ01 18861	OZA186-F7	0457
MERCEDES		
000 5402 617	OZA384-E40	0484
000 5403 817	OZA448-E38	0160
000 5403 917	OZA527-E10	0263
000 5404 017	OZA527-E6	0463
000 5406 117	OZA448-E54	0459
000 5406 417	OZA527-E13	0285
000 5408 517	OZA447-E21	0216
000 5409 017	OZA447-E22	0227
000 5409 217	OZA448-E45	0206
001 5400 417	OZA448-E29	0182
001 5400 817	OZA447-E34	0482
006 5429 617	OZA446-E13	1826
008 5429 117	OZA446-E14	1837
009 5424 117	OZA446-E13	1826
009 5428 717	OZA446-E7	1872
009 5429 017	OZA446-E14	1837
A 003 542 8118	OZA571-C10	1836
MITSUBISHI		
MD 076 706	OZA401-E66	0406
MD 078 791	OZA401-E67	0417
MD 088 616	OZA401-E68	0428
MD 109 613	OZA401-E53	0175
MD 119 210	OZA401-E63	0207
MD 128 262	OZA401-E54	0186
MD 148 738	OZA428-E3	0121
MD 150 609	OZA428-E2	0197
MD 160 578	OZA428-E4	0132
MD 182 691	OZA85-M1	0165
MD 183 145	OZA502-E34	0436
MD 183 399	OZA502-E35	0447
MD 197 852	OZA448-E52	0437
MD 300 080	OZA502-E36	0458
MD 340 904	OZA448-E53	0448
MD 351 752	OZA448-E53	0448
NISSAN		
22690 06F00	OZA401-E50	0131
22690 07G00	OZA401-E51	0142
22690 17B00	OZA401-E50	0131
22690 19B10	OZA401-E50	0131
22690 1F701	OZA448-E58	1909
22690 2A000	OZA544-N8	1804
22690 64J01	OTD2F-3K1	1907
22690 73C00	OZA446-E45	0155
22691 2A000	OZA544-N8	1804

Рекомендационный перечень

GENUINE	NTK	ORDER
NISSAN		
22690 76J00	OZA446-E45	0155
22690 81N00	OZA401-E51	0142
22690 99B00	OZA446-E45	0155
22690 IC770	OZA384-E39	0473
OPEL		
02 336 121	OZA446-E3	1866
09 118 698	OZA448-E49	0404
09 158 718	OZA334-SZ4	0418
09 202 575	OZA334-SZ1	0485
09 202 576	OZA334-SZ2	0496
09 202 577	OZA334-SZ3	0407
12 565 428	OZA531-GM1	1862
12 566 780	OZA531-GM3	1864
12 567 681	OZA531-GM2	1863
12 568 234	OZA531-GM7	1870
12 569 391	OZA531-GM6	1869
12 573 936	OZA583-GM1	1753
12 574 574	OZA531-GM22	1892
25 164 596	OZA401-E6	1882
25 177 596	OZA448-E49	0404
55 351 836	OZA575-GM2	1896
55 353 269	OZA531-GM16	1891
55 354 595	OZA531-GM22	1892
5WK9 1000	OZA334-SZ3	0407
5WK9 1701	OZA334-SZ1	0485
5WK9 1702	OZA334-SZ2	0496
5WK9 1709	OZA334-SZ4	0418
5WK9 3207	OTA7N-5A2	1938
855 300	OZA446-E6	1861
855 302	OZA446-E3	1866
855 305	OZA401-E6	1882
855 306	OZA446-E6	1861
855 307	OZA446-E3	1866
855 313	OTA7H-3C1	1954
855 315	OZA401-E6	1882
855 322	OZA446-E40	0193
855 323	OZA446-E41	0128
855 324	OTA7H-3C2	0420
855 330	OTA7L-3C3	0442
855 331	OTA7L-3C4	0431
855 333	OZA401-E6	1882
855 341	OZA447-E26	0405
855 342	OTA7N-5A1	1920
855 343	OTA7N-5A2	1938
855 345	OZA448-E49	0404
855 356	OZA334-SZ1	0485
855 357	OZA334-SZ2	0496
855 358	OZA334-SZ3	0407
855 372	OZA531-GM2	1863
855 382	OZA531-GM6	1869

GENUINE	NTK	ORDER
OPEL		
855 389	OZA334-SZ4	0418
855 391	OZA583-GM1	1753
855 395	OZA531-GM22	1892
855 397	OZA575-GM2	1896
855 400	OZA531-GM16	1891
855 507	OZA531-GM22	1892
90 009 053	OZA446-E6	1861
90 010 999	OZA446-E3	1866
90 019 999	OZA446-E3	1866
90 397 523	OZA446-E6	1861
90 397 524	OZA446-E3	1866
90 409 385	OZA446-E6	1861
90 411 959	OTA7H-3C1	1954
90 448 458	OZA446-E6	1861
90 499 264	OTA7H-3C2	0420
90 509 169	OZA446-E40	0193
90 510 147	OZA446-E6	1861
90 528 253	OTA7L-3C3	0442
90 528 640	OTA7L-3C4	0431
90 530 068	OZA447-E26	0405
90 530 586	OTA7N-5A1	1920
90 536 393	OTA7N-5A2	1938
90 543 281	OZA447-E26	0405
96 184 229	OTA7N-5E1	1965
S108748001A	OZA488-SZ1	1766
PEUGEOT		
1618 72	OZA495-PG3	1853
1628 6R	OZA527-E15	0298
1628 6S	OZA527-E16	0434
1628 6W	OZA527-E17	0445
1628 7S	OZA527-E29	0488
1628 9T	OZA448-E56	0481
1628 9W	OZA448-E57	0492
1628 A4	OZA446-E46	0280
1628 KN	OZA495-PG2	1852
1628 KP	OZA341-PG7	1815
1628 L4	OZA527-E22	0274
1628 LP	OZA334-PG1	1790
1628 NY	OZA341-PG5	1813
1628 PW	LZA06-U1	1840
1628 PX	OZA538-PG1	1818
1628 QY	OZA341-PG6	1814
1628 SW	OZA507-R2	0480
1628 TG	OZA538-PG2	1819
1628 TH	OZA341-PG8	1816
1628 V4	OZA527-E12	0220
96 027 244	OZA527-E2	0265
96 121 278 17	OZA527-E12	0220
96 127 346	OZA527-E12	0220
96 138 608	OZA527-E3	0201

Рекомендационный перечень

GENUINE	NTK	ORDER
PEUGEOT		
96 229 969	OZA527-E15	0298
96 229 970	OZA527-E16	0434
96 229 971	OZA527-E17	0445
96 230 002	OZA527-E29	0488
96 284 479	OZA448-E57	0492
96 284 479 80	OZA448-E57	0492
96 284 482	OZA448-E56	0481
96 369 209 80	LZA06-U1	1840
96 369 688 80	OZA495-PG3	1853
96 393 054 80	OZA538-PG1	1818
96 398 536 80	OZA507-R2	0480
96 424 707 80	OZA538-PG2	1819
PROTON		
MD 182 691	OZA85-M1	0165
MD 183 145	OZA502-E34	0436
RENAULT		
22690 2A000	OZA544-N8	1804
7700 100 713	OZA83-R4	0189
7700 107 434	OZA448-E50	0415
7700 108 027	OZA277-R2	0468
7700 260 909	OZA446-E11	1898
7700 273 273	OZA236-R2	0158
7700 273 715	OZA311-R2	0126
7700 854 148	OZA446-E8	1827
7700 854 506	OZA55-R1	1878
7700 860 246	OZA428-E1	1807
7700 862 426	OZA55-R2	0123
7700 864 987	OZA55-R3	0134
7700 867 295	OZA55-R4	0145
7700 867 408	OZA83-R1	0156
7700 870 318	OZA236-R1	0147
7700 871 544	OZA448-E43	0282
7700 872 820	OZA311-R1	0191
7700 872 878	OZA446-E57	0472
7700 874 327	OZA83-R2	0167
7700 874 600	OZA83-R3	0178
8200 052 063	OZA507-R2	0480
8200 145 714	OZA544-R1	1857
ROLLSROYCE		
PB 20364	OZA447-E27	0416
ROVER		
AMR 6244	OTD3J-5C1	0475
ERR 6729	OTD3G-3A1	0453
MHK 000 210	OZA447-E27	0416
MHK 100 04	OZA527-E8	0284
MHK 100 06	OZA527-E9	0498
MHK 100 21	OZA527-E18	0430

GENUINE	NTK	ORDER
ROVER		
MHK 100 23	OZA401-E5	1828
MHK 100 300	OZA222-RV1	0136
MHK 100 722	OZA341-RV2	0429
SAAB		
127 881 29	OZA575-GM1	1895
127 99169	OZA583-GM2	1754
42 39 588	OZA446-E58	0483
75 30 140	OZA401-E2	1802
SEAT		
021 906 265 A	OZA572-E13	0254
021 906 265 AC	OZA447-E36	1950
021 906 265 AK	OZA447-E31	0460
030 906 262 C	OZA510-V1	0491
030 906 262 K	LZA11-V3	1829
030 906 265	OZA446-E15	1848
030 906 265 AD	OZA447-E16	0259
030 906 265 AP	OZA572-E9	0423
030 906 265 C	OZA445-E3	1860
030 906 265 CB	OZA448-E51	0426
030 906 265 E	OZA401-E4	1822
030 906 265 J	OZA445-E4	1850
030 906 265 T	OZA572-E1	0283
032 906 265	OZA447-E30	0449
034 906 265 C	OZA446-E2	1855
034 906 265 F	OZA446-E16	1859
035 906 265 B	OZA401-E2	1802
036 906 262 D	OZA510-V5	0435
036 906 262 F	OZA510-V4	0424
036 906 262 G	LZA11-V2	1774
036 906 262 J	LZA11-V4	1842
036 906 262 T	LZA07-V3	1880
037 906 265 AD	OZA572-E10	0275
03C 906 262	OZA510-V6	1885
03D 906 265	OZA585-I1	1809
03D 906 265 A	OZA510-I1	1808
051 906 265 E	OZA401-E2	1802
06A 906 262 BR	LZA07-V1	1851
06A 906 262 BS	OZA510-V11	1884
06A 906 262 CF	LZA07-V2	1868
06A 906 265 E	OZA447-E17	0270
06A 906 265 F	OZA447-E32	0471
06A 906 265 H	OZA447-E18	0281
6K0 906 262 A	OZA510-V3	0413
SIEMENS		
5WK 90131	OTA7N-5B1	1973
5WK 90171	OTA7N-5C1	1963
5WK 93341	OTA7N-5D1	1974
5WK9 0132	OTA7N-5D2	1975

Рекомендационный перечень

GENUINE	NTK	ORDER
SIEMENS		
5WK9 0255	OTA7N-5D3	1991
5WK9 0341	OTA7N-5E1	1965
5WK9 1000	OZA334-SZ3	0407
5WK9 1701	OZA334-SZ1	0485
5WK9 1702	OZA334-SZ2	0496
5WK9 1709	OZA334-SZ4	0418
5WK9 3207	OTA7N-5A2	1938
5WK9 3341	OTA7N-5E1	1965
A2 C 53025886	OZA591-SZ1	1767
SKODA		
004 165 009	OZA446-E44	0162
030 906 262 K	LZA11-V3	1829
036 906 262 D	OZA510-V5	0435
036 906 262 G	LZA11-V2	1774
03C 906 262	OZA510-V6	1885
03D 906 265	OZA585-I1	1809
03D 906 265 A	OZA510-I1	1808
06A 906 265 E	OZA447-E17	0270
06A 906 265 F	OZA447-E32	0471
06A 906 265 H	OZA447-E18	0281
06B 906 265 A	OZA334-AU1	0474
06B 906 265 B	OZA516-AU1	0452
6U0 906 265 E	OZA457-I1	0414
STEYR-DAIMLER-PUCH		
000 540 8517	OZA447-E21	0216
SUBARU		
18213 60B00	OZA401-E6	1882
22690 AA 150	OZA446-E55	0450
SUZUKI		
18213 57B10	OZA401-E56	0154
18213 60B00	OZA401-E6	1882
18213 61A10	OZA401-E56	0154
18213 64B00	OZA401-E6	1882
19213 64B00	OZA401-E58	0166
TOYOTA		
89465-05020	OZA448-E47	0228
89465-10070	OZA502-E31	0250
89465-19275	OZA401-E49	0120
89465-19295	OZA447-E30	0449
89465-19575	OZA448-E16	1839
89465-20300	OZA573-E1	0286
89465-29316	OZA401-E49	0120
89465-29495	OZA384-E32	0133
89465-29545	OZA384-E40	0484
89465-39435	OZA384-E39	0473
89465-39445	OZA384-E40	0484

GENUINE	NTK	ORDER
VOLVO		
1326 578	OZA446-E11	1898
3061 1232	OTA4F-5C2	1948
3061 1233	OTA4N-5D1	1785
3061 1510	OTA4F-5F1	1908
3061 1511	OTA4N-5G1	1758
3061 7337	OTA4F-5C2	1948
3061 8049	OTA4F-5G2	1927
3063 0130	OTA4N-5F1	1795
3063 0132	OTA4N-5H1	1768
3063 7837	OZA583-GM2	1754
3081 4907	OZA83-VN1	0124
3086 4308	OTA4F-5E1	1942
3087 3634	OZA448-E53	0448
3110 4892	OZA324-L2	1780
3474 457	OZA446-E49	0291
3517 394	OTA4F-3B1	1763
3517 778	OZA445-E6	0258
3531 251	OZA446-E49	0291
3547 001	OTA4N-5A1	1755
3547 445	OTA4F-3C1	1773
9135 329	OTA4F-5B1	1901
9207 998	OTA4N-5A1	1755
9207 999	OTA4N-5B1	1765
9445 464	OZA324-L1	1779
VW		
021 906 265 A	OZA572-E13	0254
021 906 265 AC	OZA447-E36	1950
021 906 265 AE	OZA447-E35	0493
021 906 265 AG	OZA447-E25	0494
021 906 265 AH	OZA447-E35	0493
021 906 265 AK	OZA447-E31	0460
021 906 265 AQ	OZA447-E35	0493
021 906 265 M	OZA527-E14	0455
030 906 262 C	OZA510-V1	0491
030 906 262 F	OZA510-V2	0402
030 906 262 K	LZA11-V3	1829
030 906 265	OZA446-E15	1848
030 906 265 AD	OZA447-E16	0259
030 906 265 AE	OZA448-E31	0151
030 906 265 AP	OZA572-E9	0423
030 906 265 BD	OZA572-E11	0251
030 906 265 BH	OZA448-E31	0151
030 906 265 C	OZA445-E3	1860
030 906 265 CB	OZA448-E51	0426
030 906 265 E	OZA401-E4	1822
030 906 265 G	OZA446-E53	0237
030 906 265 J	OZA445-E4	1850
030 906 265 K	OZA446-E42	0150
030 906 265 Q	OZA445-E2	1810
030 906 265 T	OZA572-E1	0283

Информация о датчиках

Order	NTK	No. of wires	Connector No.	Length
0120	OZA401-E49	1	7	340
0121	OZA428-E3	2	11	630
0122	OZA253-F6	4	31	250
0123	OZA55-R2	3	14	368
0124	OZA83-VN1	4	29	1038
0125	OZA216-D3	4	27	710
0126	OZA311-R2	3	24	257
0128	OZA446-E41	3	14	225
0129	OZA447-E14	4	48	967
0131	OZA401-E50	1	3	170
0132	OZA428-E4	2	12	460
0133	OZA384-E32	4	34	392
0134	OZA55-R3	3	13	180
0135	OZA89-D2	4	27	360
0136	OZA222-RV1	4	33	540
0137	OZA333-H4	4	43	320
0138	OZA447-E10	4	59	675
0139	OZA446-E46	3	25	271
0142	OZA401-E51	1	3	200
0143	OZA401-E55	1	9	450
0145	OZA55-R4	3	14	228
0146	OZA112-A1	4	31	850
0147	OZA236-R1	3	14	288
0148	OZA333-H5	4	43	410
0150	OZA446-E42	4	17	583
0151	OZA448-E31	4	48	520
0152	OZA448-E37	4	40	885
0153	OZA401-E57	1	5	370
0154	OZA401-E56	1	5	380
0155	OZA446-E45	3	23	380
0156	OZA83-R1	4	28	478
0157	OZA112-A3	4	31	600
0158	OZA236-R2	3	13	180
0159	OZA333-H6	4	43	235
0160	OZA448-E38	4	41	750
0162	OZA446-E44	3	19	610
0164	OZA401-E52	1	7	470
0165	OZA85-M1	4	30	290
0166	OZA401-E58	1	6	445
0167	OZA83-R2	4	28	318
0168	OZA201-AM1	4	32	393
0169	OZA245-H1	4	44	410
0175	OZA401-E53	1	8	655
0176	OZA25-F3	1	1	550
0177	OZA73-F1	3	15	350
0178	OZA83-R3	4	28	368
0179	OZA201-AM2	4	32	393
0180	OZA245-H2	4	43	225
0182	OZA448-E29	4	47	1145
0183	OZA447-E13	4	36	517
0186	OZA401-E54	1	8	445

Order	NTK	No. of wires	Connector No.	Length
0187	OZA25-F1	1	1	550
0188	OZA186-F5	3	16	380
0189	OZA83-R4	4	28	253
0190	OZA216-D2	4	27	360
0191	OZA311-R1	3	13	255
0193	OZA446-E40	3	14	422
0194	OZA446-E43	3	26	410
0197	OZA428-E2	2	12	580
0198	OZA25-F12	1	2	550
0199	OZA33-D5	4	27	300
0201	OZA527-E3	4	58	1470
0204	OZA446-E50	3	19	710
0206	OZA448-E45	4	47	985
0207	OZA401-E63	1	8	550
0209	OZA572-E8	4	35	540
0210	OZA448-E39	4	63	270
0212	OZA333-H27	4	43	410
0213	OZA527-E7	4	40	972
0215	OZA446-E51	3	46	545
0216	OZA447-E21	4	47	565
0218	OZA527-E4	4	38	880
0220	OZA527-E12	4	58	450
0223	OZA334-A1	4	40	610
0225	OZA112-A2	4	31	300
0226	OZA446-E52	3	46	430
0227	OZA447-E22	4	47	625
0228	OZA448-E47	4	34	310
0234	OZA334-A2	4	40	980
0236	OZA112-A4	4	40	800
0237	OZA446-E53	3	46	335
0239	OZA448-E48	4	27	610
0242	OZA572-E5	4	35	400
0244	OZA519-D1	4	32	372
0245	OZA334-A3	4	40	310
0250	OZA502-E31	4	34	275
0251	OZA572-E11	4	48	780
0252	OZA572-E2	4	35	510
0253	OZA527-E5	4	38	1130
0254	OZA572-E13	4	36	585
0255	OZA421-H1	4	43	240
0256	OZA21-F3	3	78	420
0258	OZA445-E6	3	19	885
0259	OZA447-E16	4	48	550
0260	OZA448-E41	4	27	570
0263	OZA527-E10	4	41	770
0264	OZA572-E3	4	35	730
0265	OZA527-E2	4	37	510
0266	OZA501-H17	4	43	240
0269	OZA445-E7	3	19	975
0270	OZA447-E17	4	64	470
0271	OZA448-E42	4	27	555

Информация о датчиках

Order	NTK	No. of wires	Connector No.	Length
0273	OZA572-E12	4	35	910
0274	OZA527-E22	4	37	1210
0275	OZA572-E10	4	48	1430
0277	OZA333-H19	4	44	450
0280	OZA446-E48	3	45	510
0281	OZA447-E18	4	64	620
0282	OZA448-E43	4	28	255
0283	OZA572-E1	4	36	550
0284	OZA527-E8	4	33	390
0285	OZA527-E13	4	47	830
0286	OZA573-E1	4	34	310
0287	OZA527-E24	4	40	1175
0288	OZA333-H25	4	43	245
0291	OZA446-E49	3	19	1665
0293	OZA448-E44	4	27	375
0295	OZA572-E4	4	35	1420
0296	OZA527-E19	4	40	378
0298	OZA527-E15	4	49	375
0299	OZA333-H26	4	43	320
0401	OZA74-F1	4	31	480
0402	OZA510-V2	4	64	1576
0403	OZA488-D1	4	32	271
0404	OZA448-E49	4	42	320
0405	OZA447-E26	4	72	510
0406	OZA401-E66	1	8	500
0407	OZA334-SZ3	4	74	401
0408	OZA572-E14	4	47	570
0409	OZA532-A3	4	40	260
0413	OZA510-V3	4	65	1326
0414	OZA457-I1	4	36	516
0415	OZA448-E50	4	67	380
0416	OZA447-E27	4	68	290
0417	OZA401-E67	1	8	650
0418	OZA334-SZ4	4	74	271
0420	OTA7H-3C2	4	53	338
0423	OZA572-E9	4	48	620
0424	OZA510-V4	4	65	541
0425	OZA502-E28	4	43	410
0426	OZA448-E51	4	64	475
0427	OZA447-E28	4	68	340
0428	OZA401-E68	1	8	700
0429	OZA341-RV2	4	75	620
0430	OZA527-E18	4	33	545
0431	OTA7L-3C4	4	53	338
0433	OZA74-F2	4	31	280
0434	OZA527-E16	4	49	630
0435	OZA510-V5	4	64	526
0436	OZA502-E34	4	30	320
0437	OZA448-E52	4	71	340
0438	OZA447-E29	4	69	975
0440	OZA341-W2	4	42	310

Order	NTK	No. of wires	Connector No.	Length
0442	OTA7L-3C3	4	53	708
0445	OZA527-E17	4	49	1220
0446	OZA74-F3	4	31	250
0447	OZA502-E35	4	30	265
0448	OZA448-E53	4	76	400
0449	OZA447-E30	4	48	985
0450	OZA446-E55	3	80	440
0451	OZA381-D2	4	32	271
0452	OZA516-AU1	4	64	1055
0453	OTD3G-3A1	3	55	521
0455	OZA527-E14	4	36	622
0457	OZA186-F7	3	15	450
0458	OZA502-E36	4	30	285
0459	OZA448-E54	4	47	280
0460	OZA447-E31	4	48	720
0461	OZA446-E56	3	79	265
0462	OZA381-D3	4	32	393
0463	OZA527-E6	4	39	875
0464	OTD3J-5B1	4	56	730
0466	OZA527-E27	4	35	1490
0468	OZA277-R2	4	67	445
0469	OZA501-H23	4	44	450
0470	OZA448-E55	4	27	720
0471	OZA447-E32	4	64	700
0472	OZA446-E57	3	13	385
0473	OZA384-E39	4	34	300
0474	OZA334-AU1	4	65	700
0475	OTD3J-5C1	4	43	521
0477	OZA527-E28	4	63	720
0478	OZA532-A1	4	40	980
0480	OZA507-R2	4	67	445
0481	OZA448-E56	4	49	1480
0482	OZA447-E34	4	47	815
0483	OZA446-E58	3	77	1095
0484	OZA384-E40	4	34	338
0485	OZA334-SZ1	4	74	741
0486	OTA7H-5A1	4	54	968
0488	OZA527-E29	4	73	370
0489	OZA532-A2	4	40	610
0491	OZA510-V1	4	64	1686
0492	OZA448-E57	4	49	380
0493	OZA447-E35	4	66	1350
0494	OZA447-E25	4	66	1140
0496	OZA334-SZ2	4	74	571
0498	OZA527-E9	4	33	590
0499	OZA569-H1	4	43	240
1753	OZA583-GM1	4	86	312
1754	OZA583-GM2	4	87	725
1755	OTA4N-5A1	4	94	530
1757	OZA488-D2	4	32	393
1758	OTA4N-5G1	4	61	750



Информация о датчиках

Order	NTK	No. of wires	Connector No.	Length
1759	OZA112-A6	4	40	400
1760	OZA112-A7	4	40	700
1762	OZA534-A1	4	40	610
1763	OTA4F-3B1	3	57	1700
1764	OZA534-A2	4	40	410
1765	OTA4N-5B1	4	50	530
1766	OZA488-SZ1	4	32	372
1767	OZA591-SZ1	4	31	590
1768	OTA4N-5H1	4	61	750
1772	LZA07-AU1	5	91	600
1773	OTA4F-3C1	3	95	1900
1774	LZA11-V2	5	92	535
1776	OZA532-V3	4	85	481
1777	OZA572-E6	4	47	350
1778	OZA534-V1	4	64	611
1779	OZA324-L1	4	81	570
1780	OZA324-L2	4	61	1356
1782	OZA510-AU1	4	65	620
1783	OZA510-AU2	4	84	971
1784	OZA510-AU3	4	85	971
1785	OTA4N-5D1	4	90	1362
1786	OZA532-A4	4	40	1370
1789	OZA334-AU2	4	65	780
1790	OZA334-PG1	4	49	536
1792	OZA532-A5	4	40	1810
1793	OZA532-A9	4	40	810
1794	OZA532-A10	4	40	310
1795	OTA4N-5F1	4	61	343
1796	OZA532-A7	4	40	980
1798	OZA341-A1	4	40	310
1800	OZA534-A3	4	40	980
1802	OZA401-E2	1	3	472
1804	OZA544-N8	4	70	371
1805	OZA446-E12	3	19	365
1807	OZA428-E1	2	10	370
1808	OZA510-I1	4	65	231
1809	OZA585-I1	4	64	601
1810	OZA445-E2	4	17	450
1813	OZA341-PG5	4	82	536
1814	OZA341-PG6	4	82	1236
1815	OZA341-PG7	4	82	1486
1816	OZA341-PG8	4	82	1836
1818	OZA538-PG1	4	82	1236
1819	OZA538-PG2	4	82	1836
1820	OZA381-D1	4	32	372
1822	OZA401-E4	2	4	480
1825	LZA11-V1	5	92	250
1826	OZA446-E13	3	21	315
1827	OZA446-E8	3	14	375
1828	OZA401-E5	1	5	370
1829	LZA11-V3	5	92	465

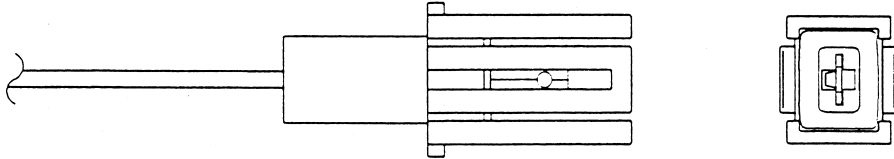
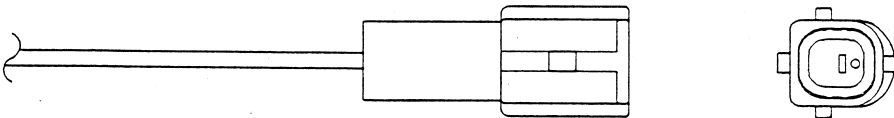
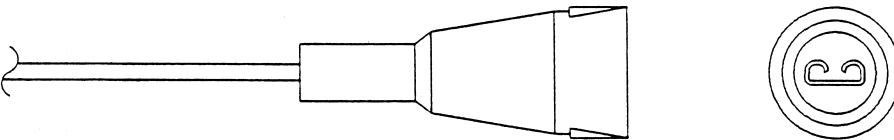
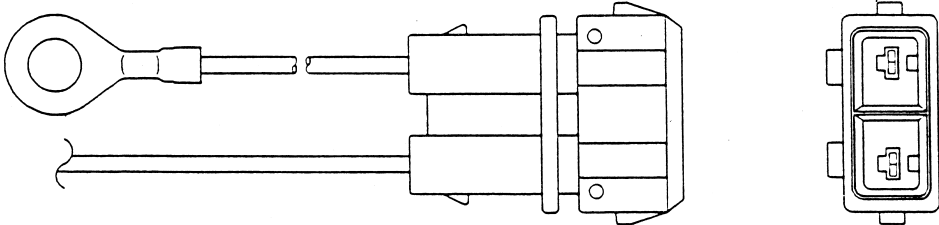
Order	NTK	No. of wires	Connector No.	Length
1833	OZA446-E1	3	19	670
1836	OZA571-C10	4	89	300
1837	OZA446-E14	3	20	760
1838	OZA446-E5	3	19	1100
1839	OZA448-E16	4	34	200
1840	LZA06-U1	5	93	375
1842	LZA11-V4	5	92	810
1845	OZA600-BM2	4	54	591
1846	OZA600-BM5	4	54	431
1847	OZA600-BM7	4	54	241
1848	OZA446-E15	3	18	970
1850	OZA445-E4	4	17	920
1851	LZA07-V1	5	92	750
1852	OZA495-PG2	4	83	536
1853	OZA495-PG3	4	83	1236
1855	OZA446-E2	3	19	975
1856	OZA114-A1	4	31	290
1857	OZA544-R1	4	88	500
1859	OZA446-E16	3	19	1215
1860	OZA445-E3	3	18	960
1861	OZA446-E6	3	14	885
1862	OZA531-GM1	4	86	660
1863	OZA531-GM2	4	74	1245
1864	OZA531-GM3	4	74	1115
1865	OZA448-E12	4	27	270
1866	OZA446-E3	3	14	1220
1867	OZA33-D8	4	27	600
1868	LZA07-V2	5	92	680
1869	OZA531-GM6	4	86	607
1870	OZA531-GM7	4	86	247
1872	OZA446-E7	3	20	510
1877	OZA446-E4	3	19	895
1878	OZA55-R1	3	14	288
1880	LZA07-V3	5	91	330
1882	OZA401-E6	1	6	320
1883	OZA510-V10	4	64	1596
1884	OZA510-V11	4	85	471
1885	OZA510-V6	4	64	251
1886	OZA510-V7	4	64	1706
1887	OZA446-E18	3	22	890
1889	OZA65-A2	1	2	650
1890	OZA89-D1	4	27	300
1891	OZA531-GM16	4	87	1465
1892	OZA531-GM22	4	74	1465
1893	OZA448-E13	4	42	820
1895	OZA575-GM1	4	49	425
1896	OZA575-GM2	4	49	355
1898	OZA446-E11	3	19	490
1901	OTA4F-5B1	4	50	405
1907	OTD2F-3K1	3	60	810
1908	OTA4F-5F1	4	61	663

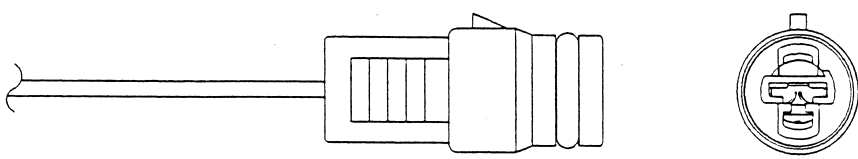
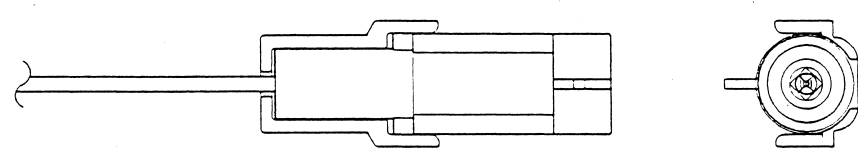
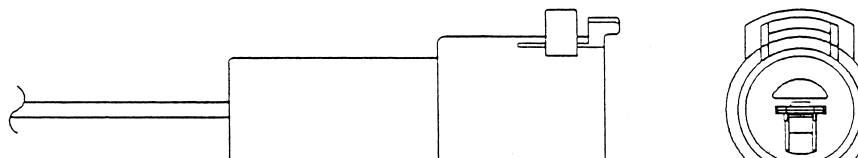
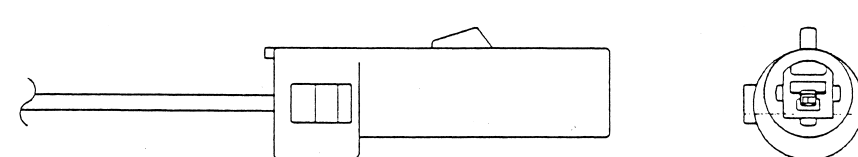
STECKERABBILDUNG CONNECTORS Вид штекера BAĞLANTI RESMİ	CONNECTEURS CONNETTORI Εικόνα φικς	CONECTORES KOŃCÓWKI PRZYŁĄCZENIOWE STEKKERAFBEELDING	ORDER STOCK	NTK
<div style="text-align: center; font-size: 24px; font-weight: bold; border: 1px solid black; border-radius: 50%; width: 30px; height: 30px; display: flex; align-items: center; justify-content: center; margin: 0 auto 20px auto;">1</div> 	0187	OZA25-F1		
	0176	OZA25-F3		
<div style="text-align: center; font-size: 24px; font-weight: bold; border: 1px solid black; border-radius: 50%; width: 30px; height: 30px; display: flex; align-items: center; justify-content: center; margin: 0 auto 20px auto;">2</div> 	0198	OZA25-F12		
	1889	OZA65-A2		
<div style="text-align: center; font-size: 24px; font-weight: bold; border: 1px solid black; border-radius: 50%; width: 30px; height: 30px; display: flex; align-items: center; justify-content: center; margin: 0 auto 20px auto;">3</div> 	1802	OZA401-E2		
	0131	OZA401-E50		
	0142	OZA401-E51		
<div style="text-align: center; font-size: 24px; font-weight: bold; border: 1px solid black; border-radius: 50%; width: 30px; height: 30px; display: flex; align-items: center; justify-content: center; margin: 0 auto 20px auto;">4</div> 	1822	OZA401-E4		

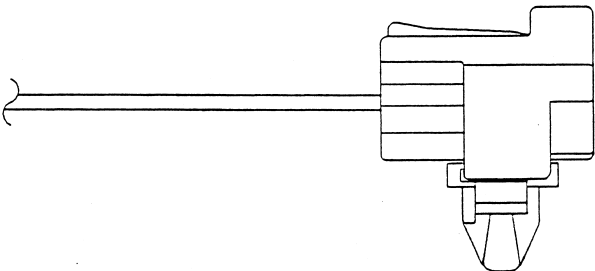
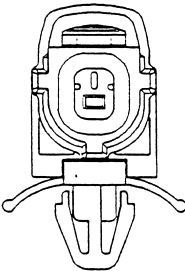
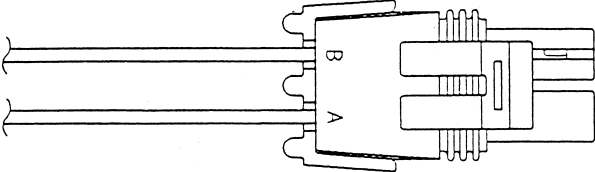
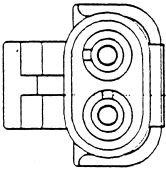
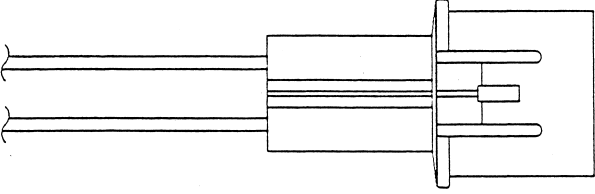
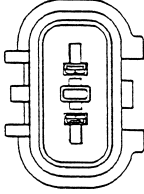
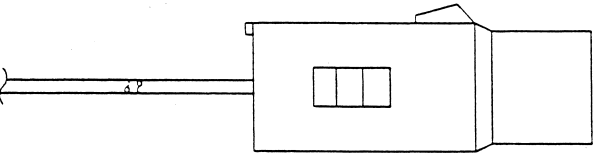
STECKERABBILDUNG CONNECTORS Вид штекера BAĞLANTI RESMİ	CONNECTEURS CONNETTORI Εικόνα φις	CONECTORES KOŃCÓWKI PRZYŁĄCZENIOWE STEKKERAFBEELDING	ORDER STOCK	NTK
<div style="text-align: center; font-weight: bold; font-size: 24px; margin-bottom: 10px;">5</div> 	1828	OZA401-E5		
	0154	OZA401-E56		
	0153	OZA401-E57		
<div style="text-align: center; font-weight: bold; font-size: 24px; margin-bottom: 10px;">6</div> 	1882	OZA401-E6		
	0166	OZA401-E58		
<div style="text-align: center; font-weight: bold; font-size: 24px; margin-bottom: 10px;">7</div> 	0120	OZA401-E49		
	0164	OZA401-E52		
<div style="text-align: center; font-weight: bold; font-size: 24px; margin-bottom: 10px;">8</div> 	1940	OZA25-KH1		
	1969	OZA25-KH3		
	0175	OZA401-E53		
	0186	OZA401-E54		
	0207	OZA401-E63		
	0406	OZA401-E66		
	0417	OZA401-E67		
0428	OZA401-E68			

STECKERABBILDUNG CONNECTORS Вид штекера BAĞLANTI RESMİ	CONNECTEURS CONNETTORI Εικόνα φικς	CONECTORES KOŃCÓWKI PRZYŁĄCZENIOWE STEKKERAFBEELDING	ORDER STOCK	NTK
9			0143	OZA401-E55
10			1807	OZA428-E1
11			0121	OZA428-E3
12			0197	OZA428-E2
			0132	OZA428-E4

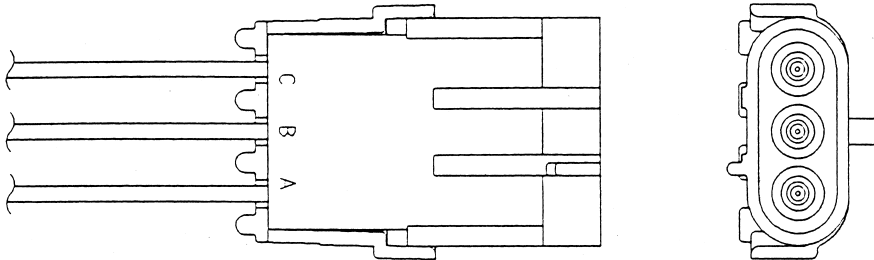
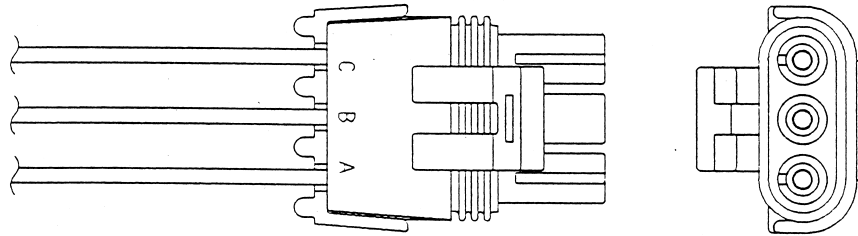
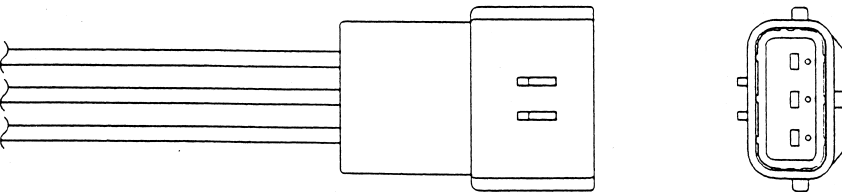
STECKERABBILDUNG CONNECTORS Вид штекера BAĞLANTI RESMİ	CONNECTEURS CONNETTORI Εικόνα φις	CONECTORES KOŃCÓWKI PRZYŁĄCZENIOWE STEKKERAFBEELDING	ORDER STOCK	NTK
13 			0134	OZA55-R3
			0158	OZA236-R2
			0191	OZA311-R1
			0472	OZA446-E57
14 			1878	OZA55-R1
			0123	OZA55-R2
			0145	OZA55-R4
			0147	OZA236-R1
			1866	OZA446-E3
			1861	OZA446-E6
			1827	OZA446-E8
			0193	OZA446-E40
			0128	OZA446-E41
15 			0177	OZA73-F1
			0457	OZA186-F7

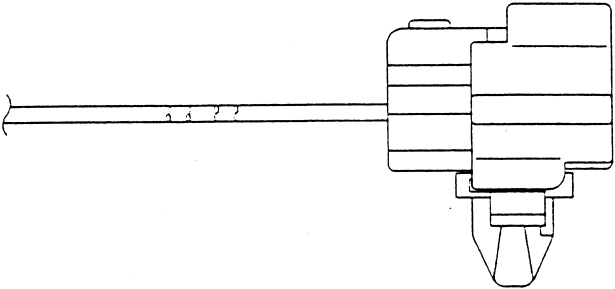
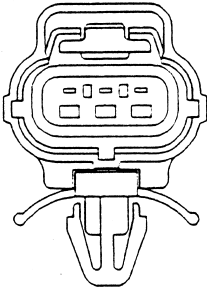
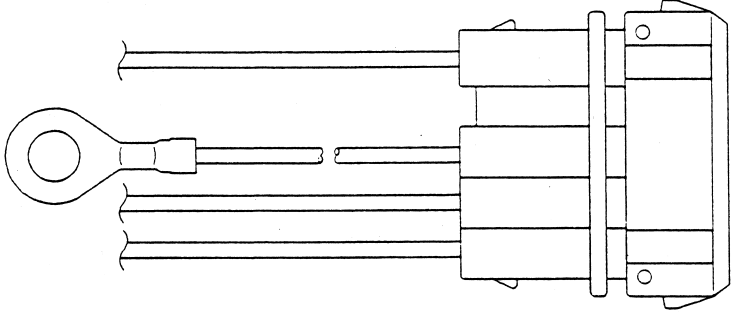
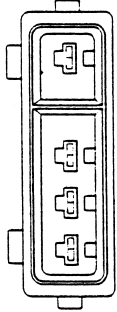
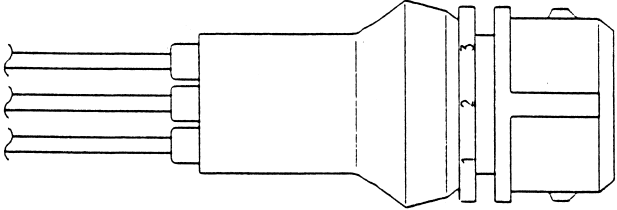
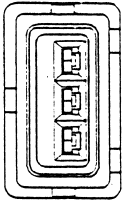
STECKERABBILDUNG CONNECTORS Вид штекера BAĞLANTI RESMİ	CONNECTEURS CONNETTORI Εικόνα φics	CONECTORES KOŃCÓWKI PRZYŁĄCZENIOWE STEKKERAFBEELDING	ORDER STOCK	NTK
16			0188	OZA186-F5
17			1810 1850 0150	OZA445-E2 OZA445-E4 OZA446-E42
18			1860 1848	OZA445-E3 OZA446-E15

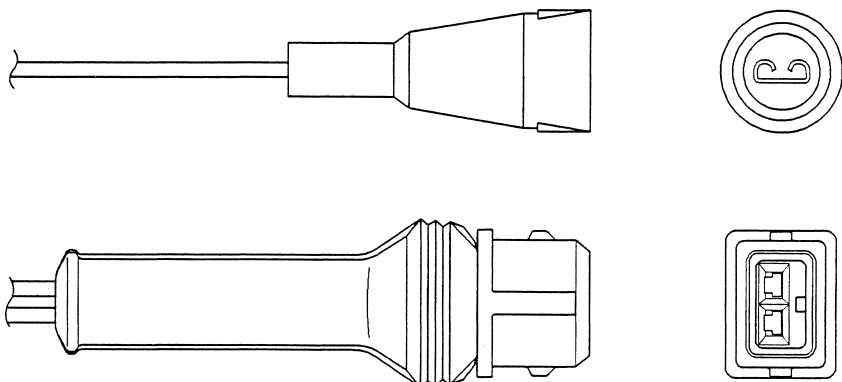
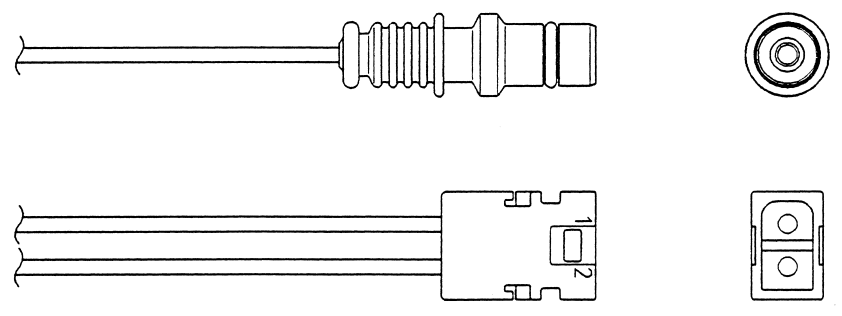
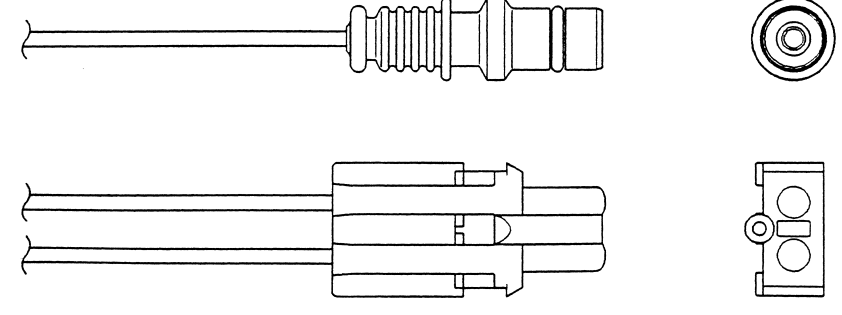
STECKERABBILDUNG CONNECTORS Вид штекера BAĞLANTI RESMİ	CONNECTEURS CONNETTORI Εικόνα φίς	CONECTORES KOŃCÓWKI PRZYŁĄCZENIOWE STEKKERAFBEELDING	ORDER STOCK	NTK
<div data-bbox="92 280 151 331" style="border: 1px solid black; border-radius: 50%; width: 30px; height: 30px; display: flex; align-items: center; justify-content: center; margin-bottom: 10px;">19</div> 	0258	OZA445-E6		
	0269	OZA445-E7		
	1833	OZA446-E1		
	1855	OZA446-E2		
	1877	OZA446-E4		
	1838	OZA446-E5		
	1898	OZA446-E11		
	1805	OZA446-E12		
	1859	OZA446-E16		
	0162	OZA446-E44		
	0291	OZA446-E49		
	0204	OZA446-E50		
<div data-bbox="92 1205 151 1256" style="border: 1px solid black; border-radius: 50%; width: 30px; height: 30px; display: flex; align-items: center; justify-content: center; margin-bottom: 10px;">20</div> 	1872	OZA446-E7		
	1837	OZA446-E14		
<div data-bbox="92 1675 151 1727" style="border: 1px solid black; border-radius: 50%; width: 30px; height: 30px; display: flex; align-items: center; justify-content: center; margin-bottom: 10px;">21</div> 	1826	OZA446-E13		

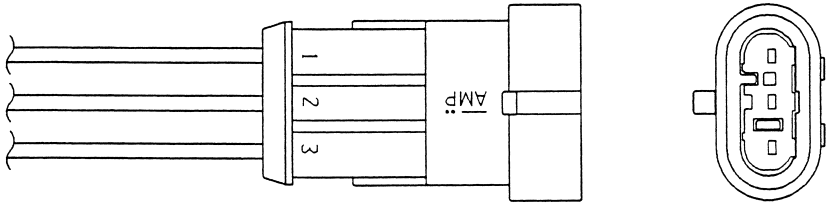
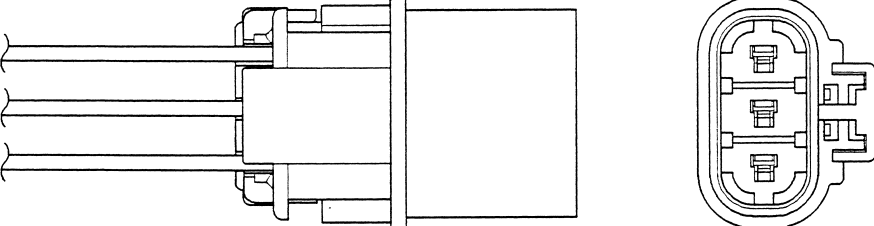
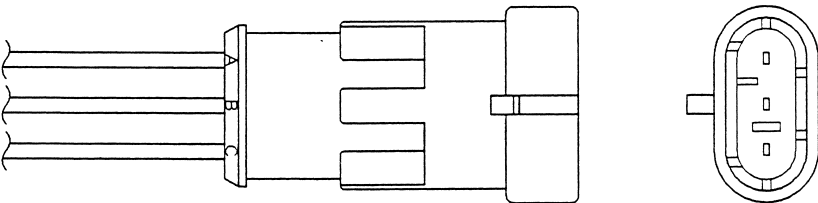
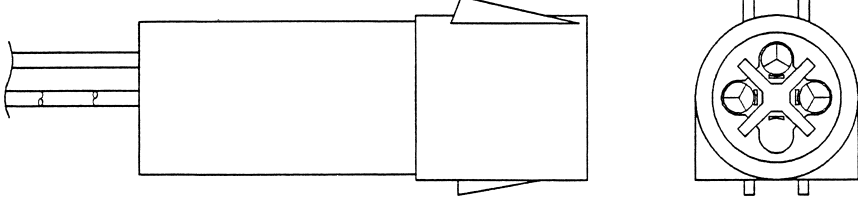
STECKERABBILDUNG CONNECTORS Вид штекера BAĞLANTI RESMİ	CONNECTEURS CONNETTORI Εικόνα φικς	CONECTORES KOŃCÓWKI PRZYŁĄCZENIOWE STEKKERAFBEELDING	ORDER STOCK	NTK
<p>22</p> 			1887	OZA446-E18
<p>23</p> 			0155	OZA446-E45
<p>24</p> 			0126	OZA311-R2
<p>25</p> 			0139	OZA446-E46

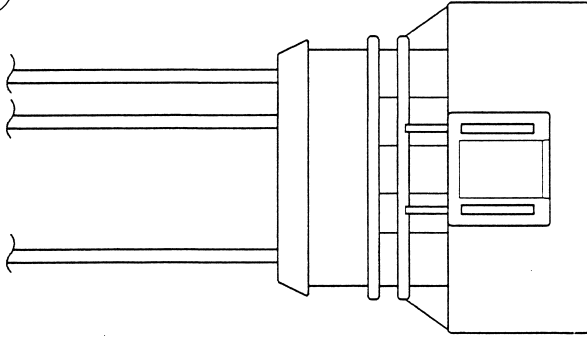
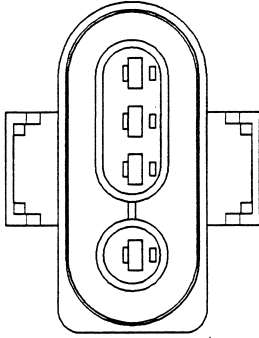
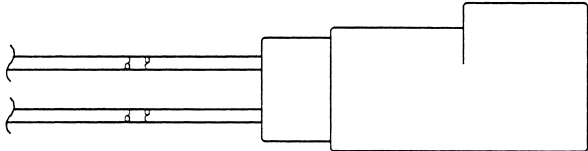
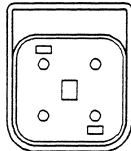
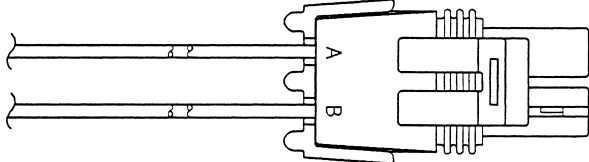
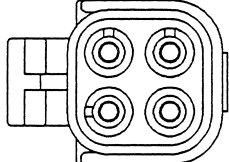
STECKERABBILDUNG CONNECTORS Вид штекера BAĞLANTI RESMİ	CONNECTEURS CONNETTORI Εικόνα φις	CONECTORES KOŃCÓWKI PRZYŁĄCZENIOWE STEKKERAFBEELDING	ORDER STOCK	NTK
26			0194	OZA446-E43
27			0199 1867 1890 0135 0190 0125 1865 0260 0271 0293 0239 0470	OZA33-D5 OZA33-D8 OZA89-D1 OZA89-D2 OZA216-D2 OZA216-D3 OZA448-E12 OZA448-E41 OZA448-E42 OZA448-E44 OZA448-E48 OZA448-E55
28			0156 0167 0178 0189 0282	OZA83-R1 OZA83-R2 OZA83-R3 OZA83-R4 OZA448-E43

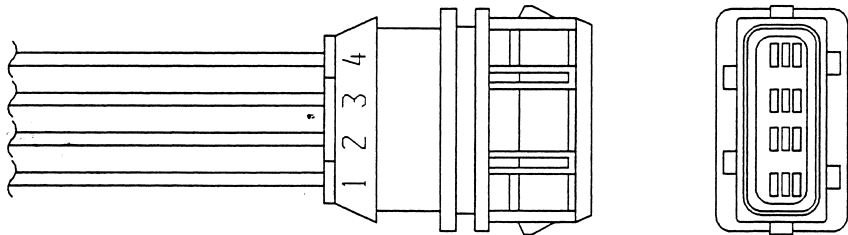
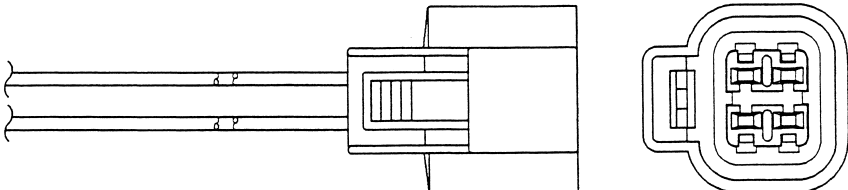
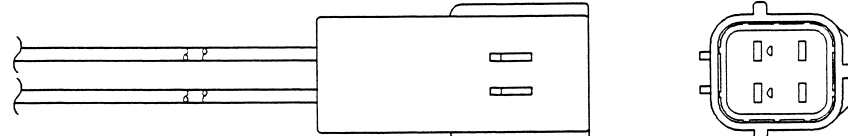
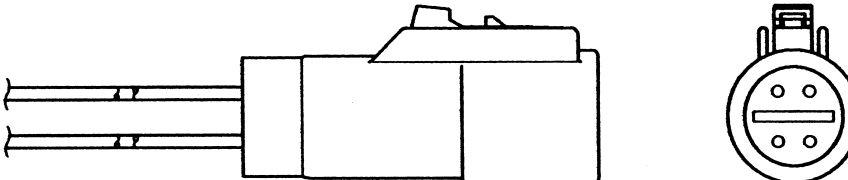
STECKERABBILDUNG CONNECTORS Вид штекера BAĞLANTI RESMİ	CONNECTEURS CONNETTORI Εικόνα φικς	CONECTORES KOŃCÓWKI PRZYŁĄCZENIOWE STEKKERAFBEELDING	ORDER STOCK	NTK
29 			0124	OZA83-VN1
30 			0165	OZA85-M1
			0436	OZA502-E34
			0447	OZA502-E35
			0458	OZA502-E36
31 			0401	OZA74-F1
			0433	OZA74-F2
			0446	OZA74-F3
			0146	OZA112-A1
			0225	OZA112-A2
			0157	OZA112-A3
			1856	OZA114-A1
			0122	OZA253-F6
			1767	OZA591-SZ1
32 			0168	OZA201-AM1
			0179	OZA201-AM2
			1820	OZA381-D1
			0451	OZA381-D2
			0462	OZA381-D3
			0403	OZA488-D1
			1757	OZA488-D2
			1766	OZA488-SZ1
			0244	OZA519-D1

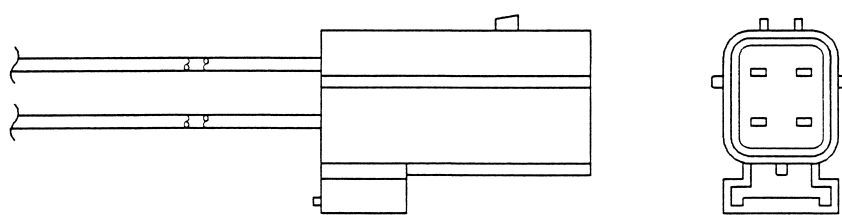
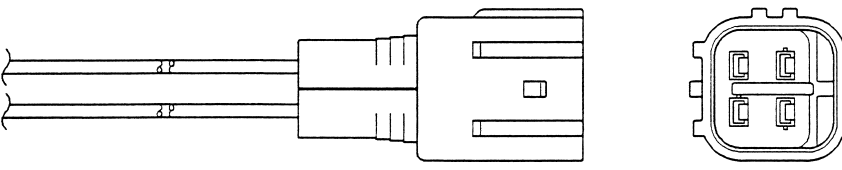
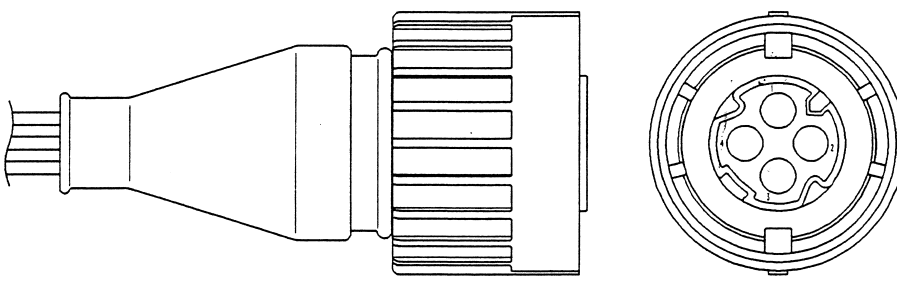
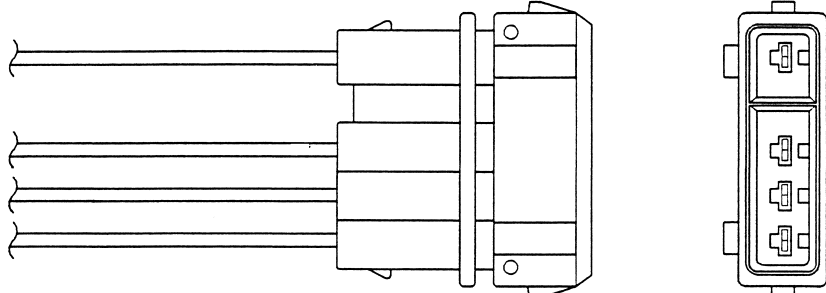
STECKERABBILDUNG CONNECTORS Вид штекера BAĞLANTI RESMİ	CONNECTEURS CONNETTORI Εικόνα φίς	CONECTORES KOŃCÓWKI PRZYŁĄCZENIOWE STEKKERAFBEELDING	ORDER STOCK	NTK
33 			0136	OZA222-RV1
			0284	OZA527-E8
			0498	OZA527-E9
			0430	OZA527-E18
34 			0133	OZA384-E32
			0473	OZA384-E39
			0484	OZA384-E40
			1839	OZA448-E16
			0228	OZA448-E47
35 			0466	OZA527-E27
			0252	OZA572-E2
			0264	OZA572-E3
			0295	OZA572-E4
			0242	OZA572-E5
			0209	OZA572-E8
36 			0183	OZA447-E13
			0414	OZA457-I1
			0455	OZA527-E14
			0283	OZA572-E1
			0254	OZA572-E13

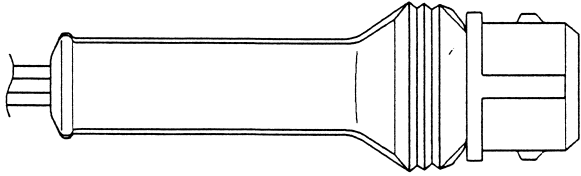
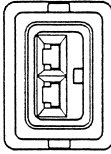
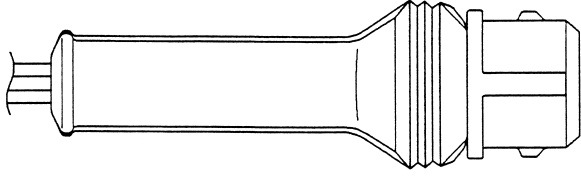
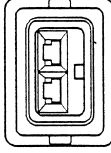
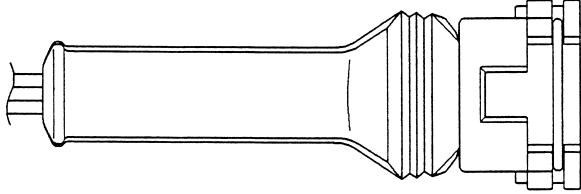
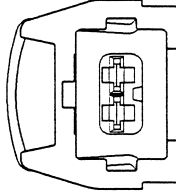
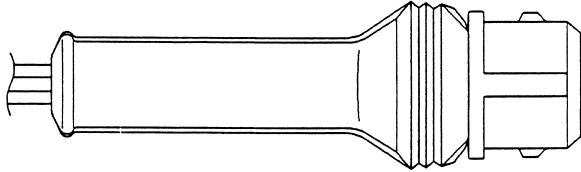
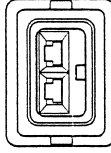
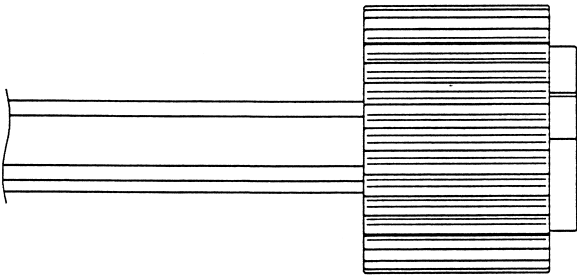
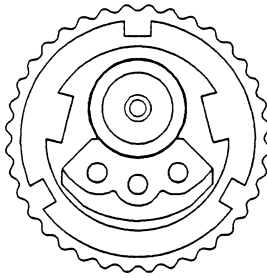
STECKERABBILDUNG CONNECTORS Вид штекера BAĞLANTI RESMİ	CONNECTEURS CONNETTORI Εικόνα φικς	CONECTORES KOŃCÓWKI PRZYŁĄCZENIOWE STEKKERAFBEELDING	ORDER STOCK	NTK
37			0265	OZA527-E2
			0274	OZA527-E22
38			0218	OZA527-E4
			0253	OZA527-E5
39			0463	OZA527-E6

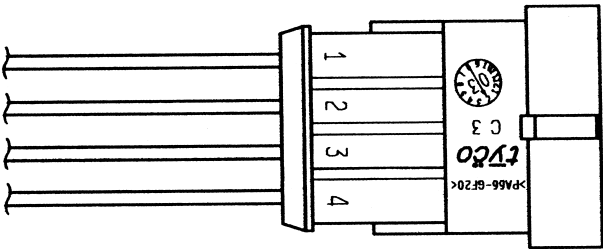
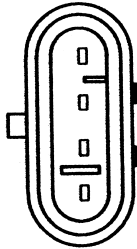
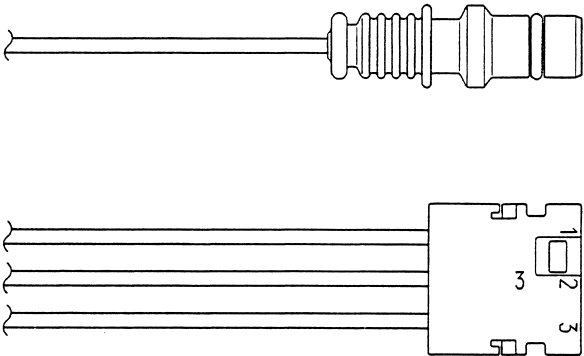
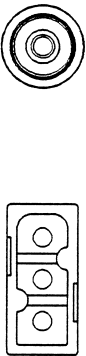

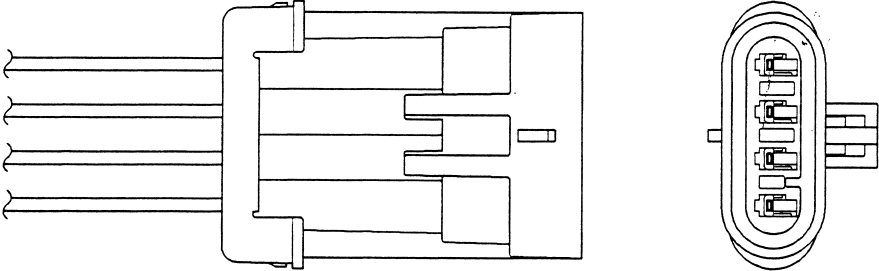
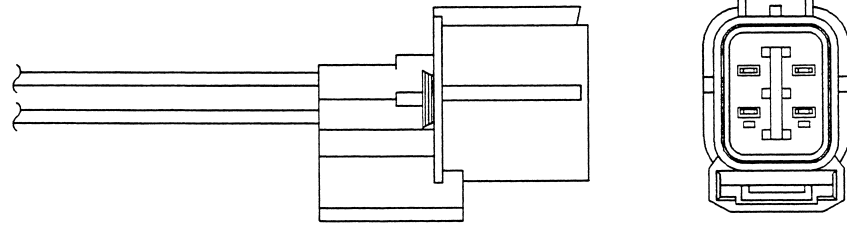
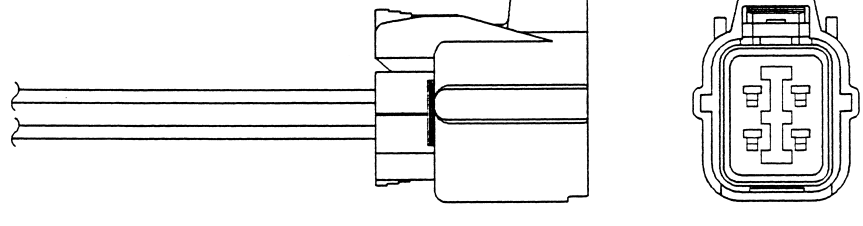
STECKERABBILDUNG CONNECTORS Вид штекера BAĞLANTI RESMİ	CONNECTEURS CONNETTORI Εικόνα φις	CONECTORES KOŃCÓWKI PRZYŁĄCZENIOWE STEKKERAFBEELDING	ORDER STOCK	NTK
<div style="display: flex; align-items: center;"> <div style="margin-right: 20px;"> <p>40</p>  </div> <div>  </div> </div>			0236	OZA112-A4
			1759	OZA112-A6
			1760	OZA112-A7
			0223	OZA334-A1
			0234	OZA334-A2
			0245	OZA334-A3
			1798	OZA341-A1
			0152	OZA448-E37
			0213	OZA527-E7
			0296	OZA527-E19
			0287	OZA527-E24
			0478	OZA532-A1
			0489	OZA532-A2
			0409	OZA532-A3
			1786	OZA532-A4
			1792	OZA532-A5
			1796	OZA532-A7
			1793	OZA532-A9
			1794	OZA532-A10
			1762	OZA534-A1
1764	OZA534-A2			
1800	OZA534-A3			
<div style="display: flex; align-items: center;"> <div style="margin-right: 20px;"> <p>41</p>  </div> <div>  </div> </div>			0160	OZA448-E38
			0263	OZA527-E10

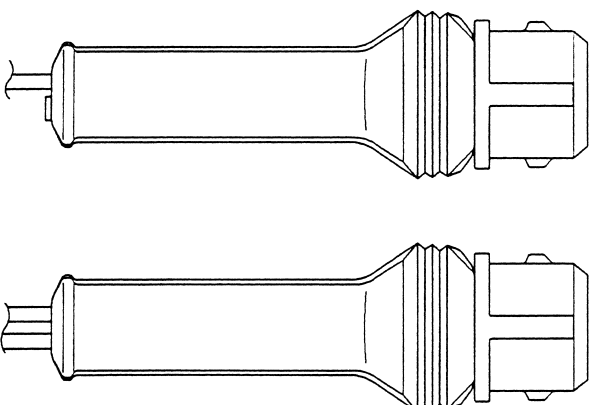
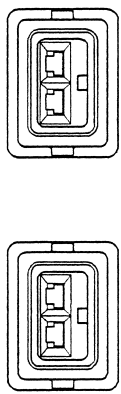
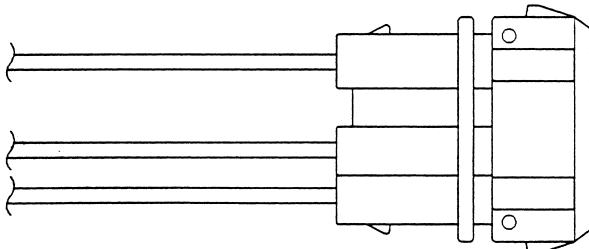
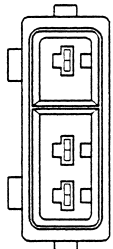
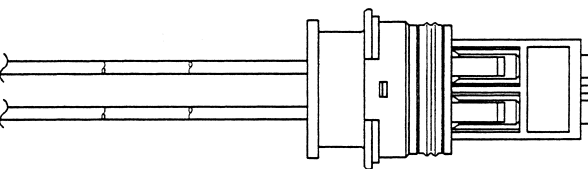
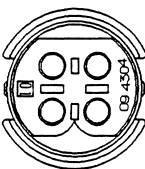
STECKERABBILDUNG CONNECTORS Вид штекера BAĞLANTI RESMİ	CONNECTEURS CONNETTORI Εικόνα φικς	CONECTORES KOŃCÓWKI PRZYŁĄCZENIOWE STEKKERAFBEELDING	ORDER STOCK	NTK
42 			0440	OZA341-W2
			1893	OZA448-E13
			0404	OZA448-E49
43 			0475	OTD3J-5C1
			0180	OZA245-H2
			0137	OZA333-H4
			0148	OZA333-H5
			0159	OZA333-H6
			0288	OZA333-H25
			0299	OZA333-H26
			0212	OZA333-H27
			0255	OZA421-H1
			0266	OZA501-H17
			0425	OZA502-E28
			0499	OZA569-H1
44 			0169	OZA245-H1
			0277	OZA333-H19
			0469	OZA501-H23

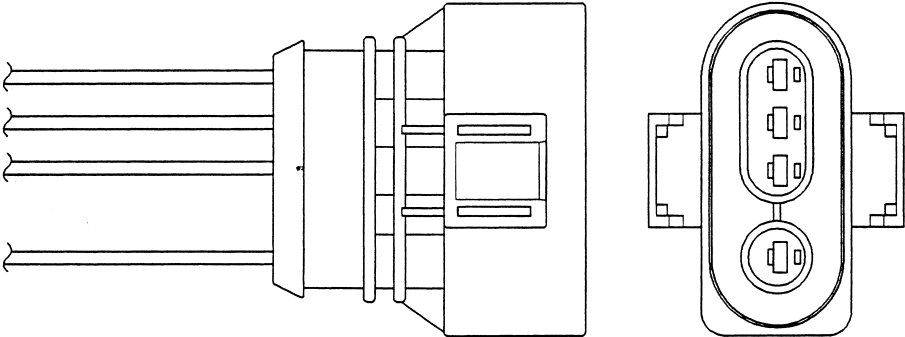
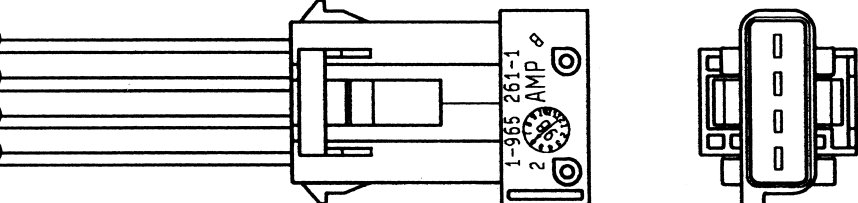
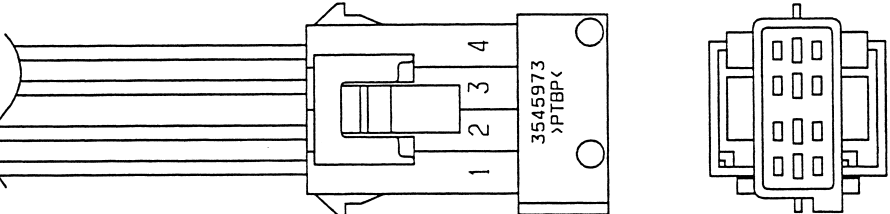
STECKERABBILDUNG CONNECTORS Вид штекера BAĞLANTI RESMİ	CONNECTEURS CONNETTORI Εικόνα φις	CONECTORES KOŃCÓWKI PRZYŁĄCZENIOWE STEKKERAFBEELDING	ORDER STOCK	NTK
45			0280	OZA446-E48
46			0215 0226 0237	OZA446-E51 OZA446-E52 OZA446-E53
47			1963 0216 0227 0482 0182 0206 0459 0285 1777 0408	OTA7N-5C1 OZA447-E21 OZA447-E22 OZA447-E34 OZA448-E29 OZA448-E45 OZA448-E54 OZA527-E13 OZA572-E6 OZA572-E14

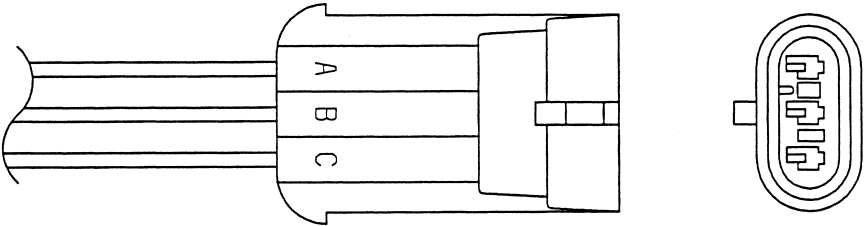
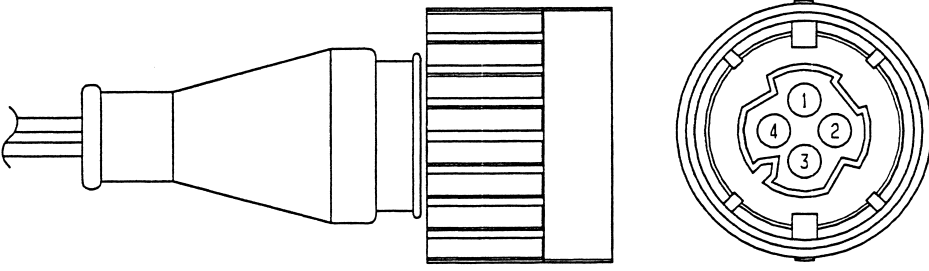
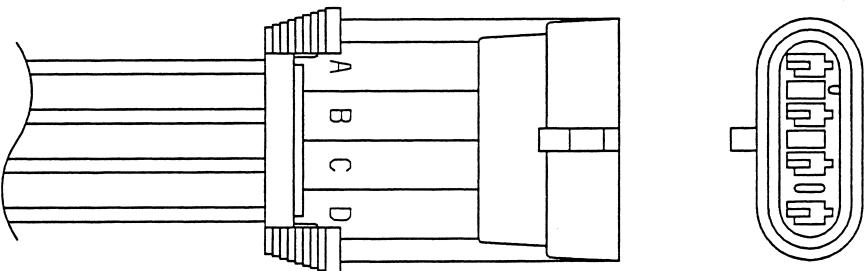
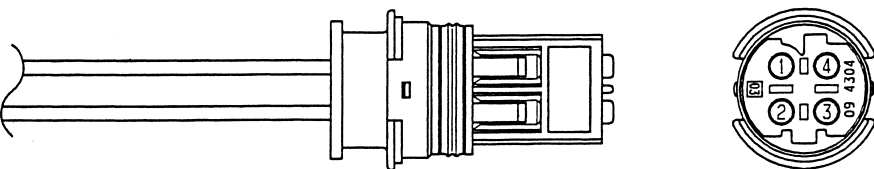

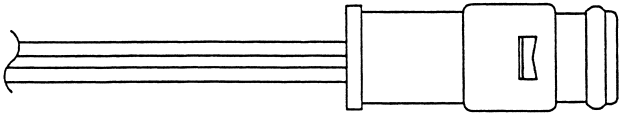
STECKERABBILDUNG CONNECTORS Вид штекера BAĞLANTI RESMİ	CONNECTEURS CONNETTORI Εικόνα φικς	CONECTORES KOŃCÓWKI PRZYŁĄCZENIOWE STEKKERAFBEELDING	ORDER STOCK	NTK
48 			0129	OZA447-E14
			0259	OZA447-E16
			0449	OZA447-E30
			0460	OZA447-E31
			1950	OZA447-E36
			0151	OZA448-E31
			0423	OZA572-E9
			0275	OZA572-E10
			0251	OZA572-E11
			49 	
0481	OZA448-E56			
0492	OZA448-E57			
0298	OZA527-E15			
0434	OZA527-E16			
0445	OZA527-E17			
1895	OZA575-GM1			
1896	OZA575-GM2			
50 			1901	OTA4F-5B1
			1765	OTA4N-5B1

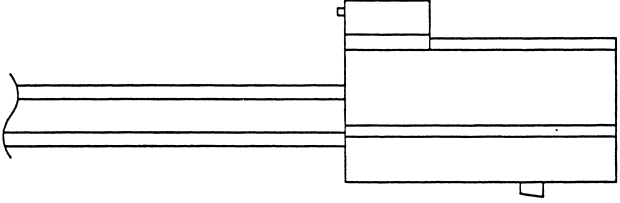
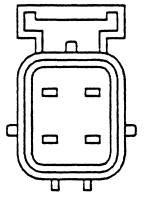
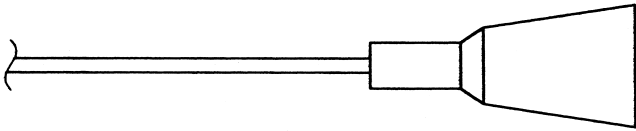
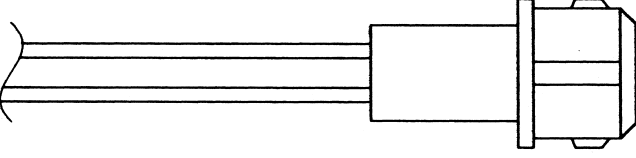
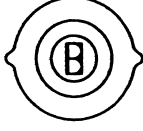
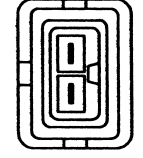
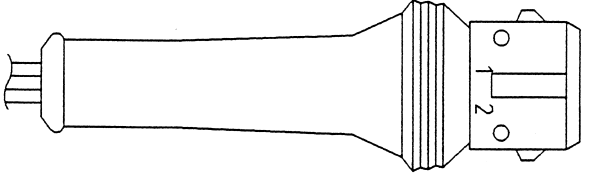
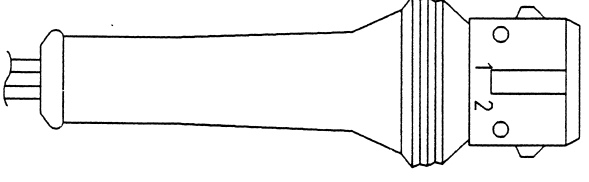
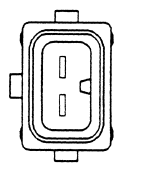
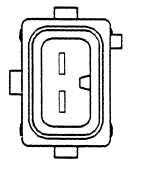
STECKERABBILDUNG CONNECTORS Вид штекера BAĞLANTI RESMİ	CONNECTEURS CONNETTORI Εικόνα φίς	CONECTORES KOŃCÓWKI PRZYŁĄCZENIOWE STEKKERAFBEELDING	ORDER STOCK	NTK
51 	1921	OTA5F-3C1		
	1928	OTA6F-3A1		
52 	1932	OTA7H-3A1		
	1943	OTA7H-3A2		
	1973	OTA7W-5B1		
53 	1954	OTA7H-3C1		
	0420	OTA7H-3C2		
	0442	OTA7L-3C3		
	0431	OTA7L-3C4		
	1920	OTA7N-5A1		
	1938	OTA7N-5A2		
	1965	OTA7N-5E1		
54 	1845	OZA600-BM2		
	1846	OZA600-BM5		
	1847	OZA600-BM7		
	0486	OTA7H-5A1		
	1974	OTA7N-5D1		
	1975	OTA7N-5D2		
	1991	OTA7N-5D3		

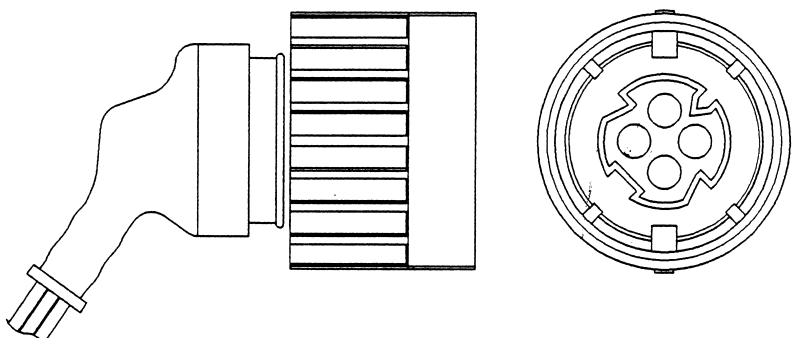
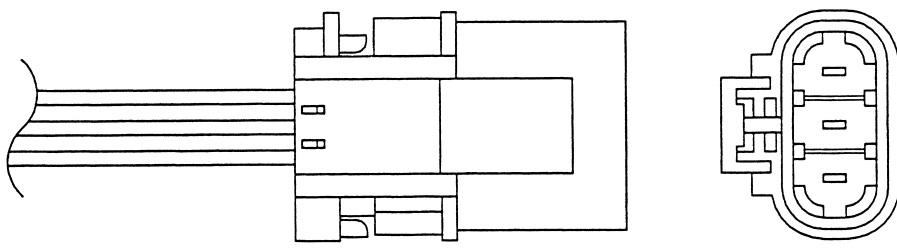
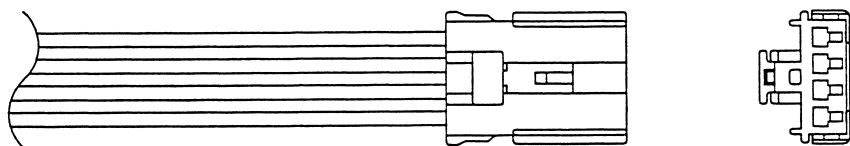
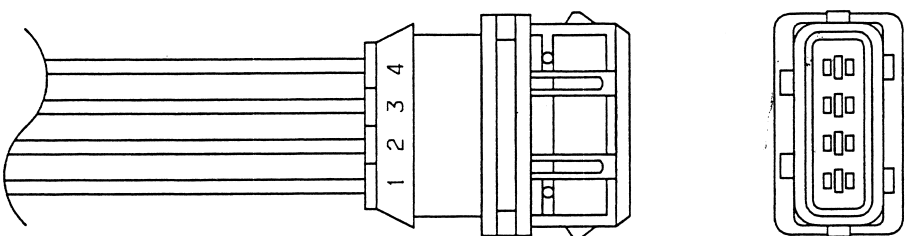
STECKERABBILDUNG CONNECTORS Вид штекера BAĞLANTI RESMİ	CONNECTEURS CONNETTORI Εικόνα φics	CONECTORES KOŃCÓWKI PRZYŁĄCZENIOWE STEKKERAFBEELDING	ORDER STOCK	NTK
55 			0453	OTD3G-3A1
56 			0464	OTD3J-5B1
57  		 	1763	OTA4F-3B1
58  		 	0201 0220	OZA527-E3 OZA527-E12

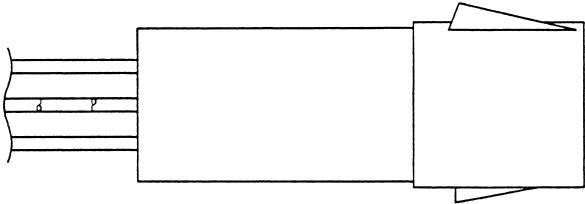
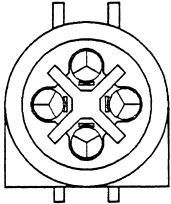
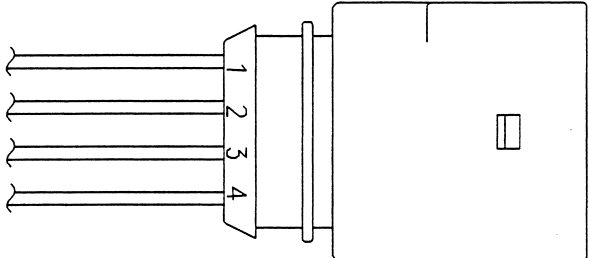
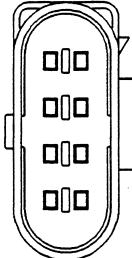
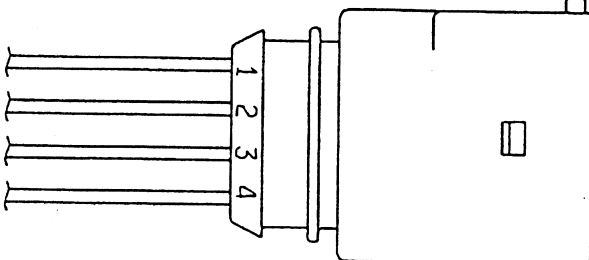
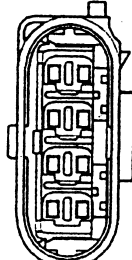
STECKERABBILDUNG CONNECTORS Вид штекера BAĞLANTI RESMİ	CONNECTEURS CONNETTORI Εικόνα φις	CONECTORES KOŃCÓWKI PRZYŁĄCZENIOWE STEKKERAFBEELDING	ORDER STOCK	NTK
59 			0138	OZA447-E10
60 			1907	OTD2F-3K1
61 			1942 1908 1927 1795 1758 1768 1780	OTA4F-5E1 OTA4F-5F1 OTA4F-5G2 OTA4N-5F1 OTA4N-5G1 OTA4N-5H1 OZA324-L2
62 			1948	OTA4F-5C2

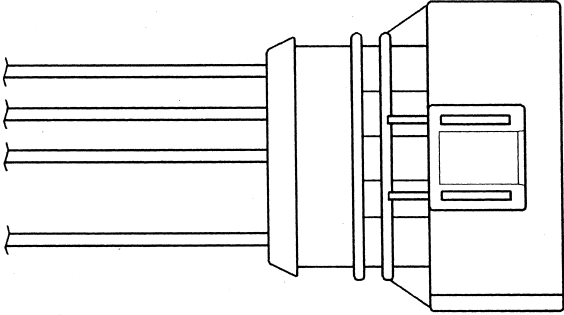
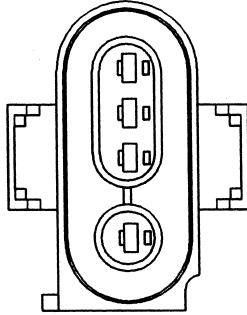
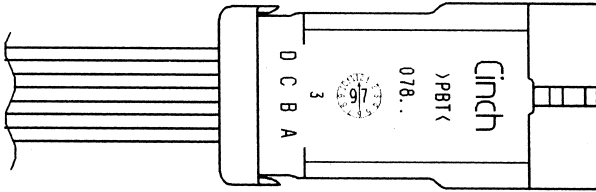
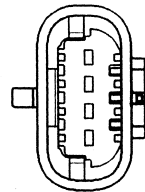
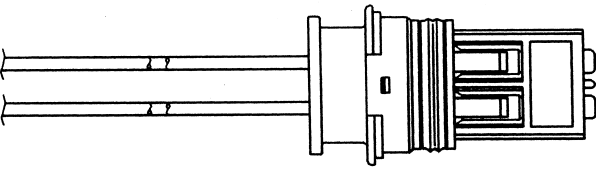
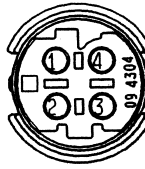
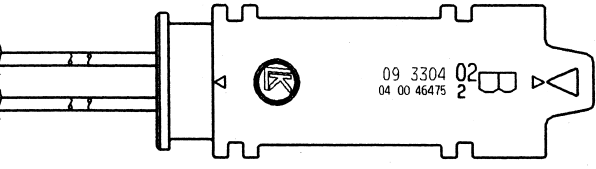
STECKERABBILDUNG CONNECTORS Вид штекера BAĞLANTI RESMİ	CONNECTEURS CONNETTORI Εικόνα φικς	CONECTORES KOŃCÓWKI PRZYŁĄCZENIOWE STEKKERAFBEELDING	ORDER STOCK	NTK
<div style="display: flex; align-items: center;"> <div style="margin-right: 20px;"> <p>63</p>  </div> <div>  </div> </div>	0210	OZA448-E39		
	0477	OZA527-E28		
<div style="display: flex; align-items: center;"> <div style="margin-right: 20px;"> <p>64</p>  </div> <div>  </div> </div>	0270	OZA447-E17		
	0281	OZA447-E18		
	0471	OZA447-E32		
	0426	OZA448-E51		
	0491	OZA510-V1		
	0402	OZA510-V2		
	0435	OZA510-V5		
	1885	OZA510-V6		
	1886	OZA510-V7		
	1883	OZA510-V10		
	0452	OZA516-AU1		
	1778	OZA534-V1		
	1809	OZA585-I1		
<div style="display: flex; align-items: center;"> <div style="margin-right: 20px;"> <p>65</p>  </div> <div>  </div> </div>	0474	OZA334-AU1		
	1789	OZA334-AU2		
	1782	OZA510-AU1		
	1808	OZA510-I1		
	0413	OZA510-V3		
	0424	OZA510-V4		

STECKERABBILDUNG CONNECTORS Вид штекера BAĞLANTI RESMİ	CONNECTEURS CONNETTORI Εικόνα φής	CONECTORES KOŃCÓWKI PRZYŁĄCZENIOWE STEKKERAFBEELDING	ORDER STOCK	NTK
66			0494	OZA447-E25
			0493	OZA447-E35
67			0468	OZA277-R2
			0415	OZA448-E50
			0480	OZA507-R2
68			0416	OZA447-E27
			0427	OZA447-E28
69			0438	OZA447-E29

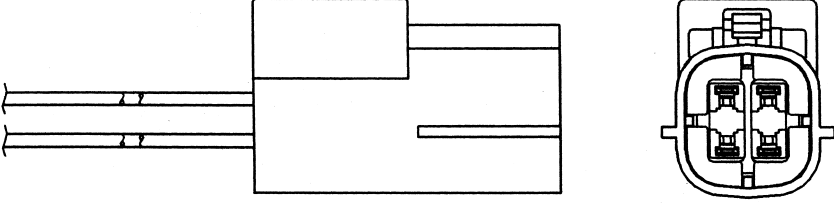
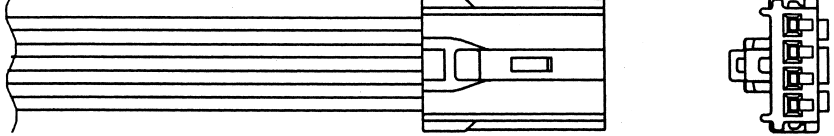
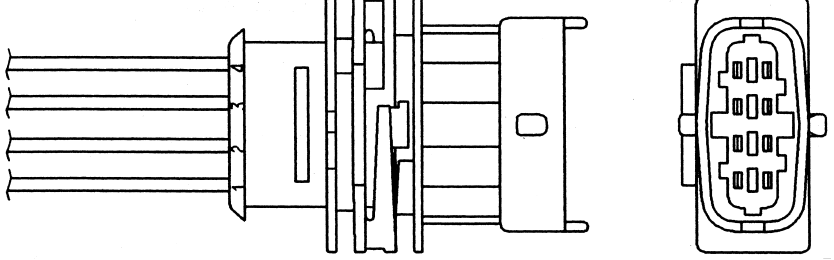
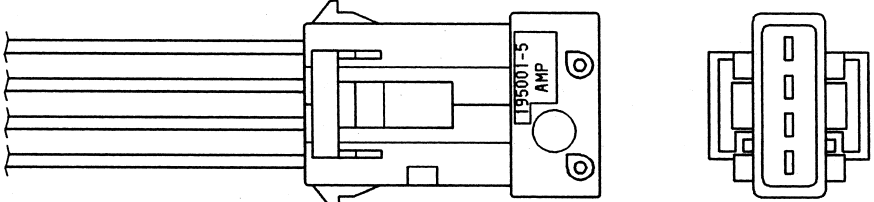
STECKERABBILDUNG CONNECTORS Вид штекера BAĞLANTI RESMİ	CONNECTEURS CONNETTORI Εικόνα φικς	CONECTORES KOŃCÓWKI PRZYŁĄCZENIOWE STEKKERAFBEELDING	ORDER STOCK	NTK
70 			1909	OZA448-E58
			1804	OZA544-N8
71 			0437	OZA448-E52
72 			0405	OZA447-E26
73 			0488	OZA527-E29

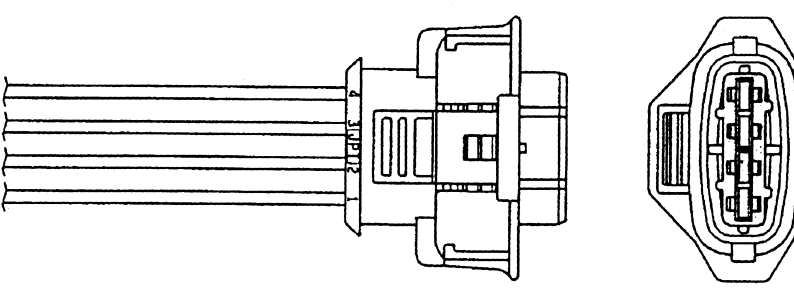
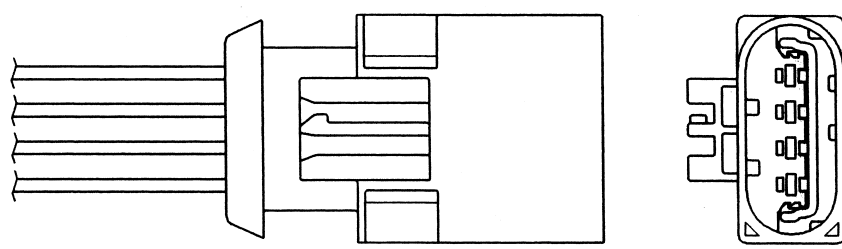
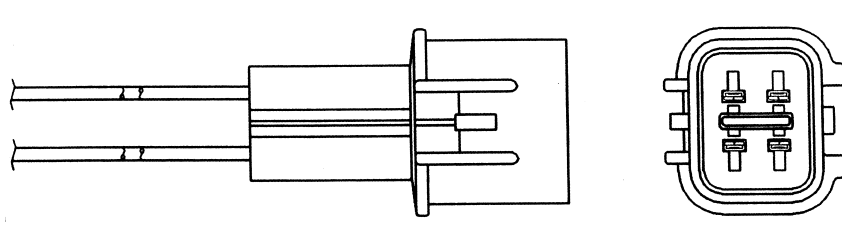
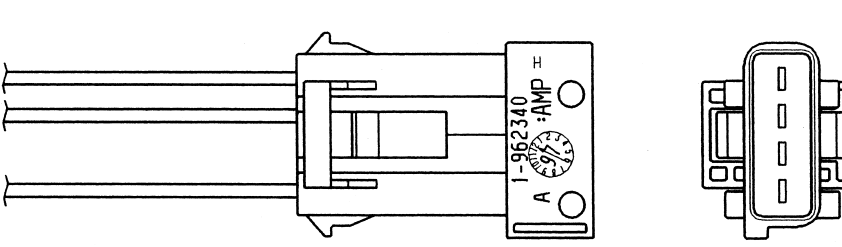
STECKERABBILDUNG CONNECTORS Вид штекера BAĞLANTI RESMİ	CONNECTEURS CONNETTORI Εικόνα φις	CONECTORES KOŃCÓWKI PRZYŁĄCZENIOWE STEKKERAFBEELDING	ORDER STOCK	NTK
74 			0485	OZA334-SZ1
			0496	OZA334-SZ2
			0407	OZA334-SZ3
			0418	OZA334-SZ4
			1863	OZA531-GM2
			1864	OZA531-GM3
			1892	OZA531-GM22
75 			0429	OZA341-RV2
76 			0448	OZA448-E53
77 			0483	OZA446-E58

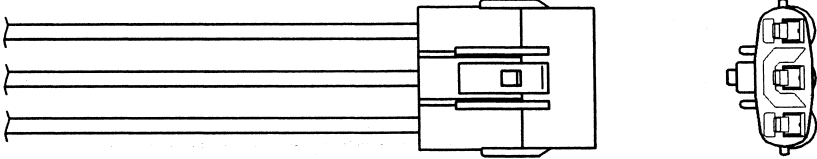
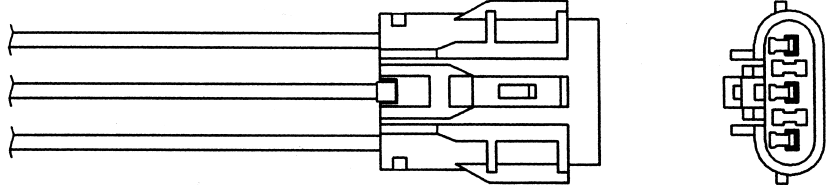
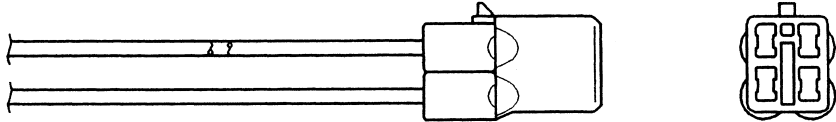
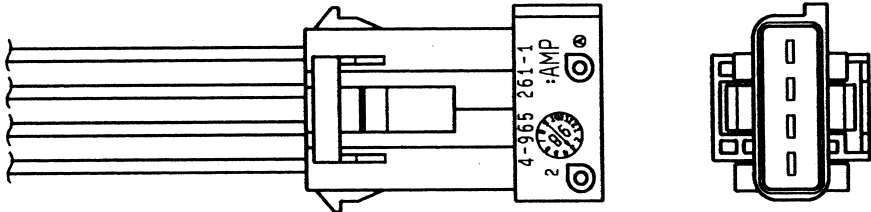
STECKERABBILDUNG CONNECTORS Вид штекера BAĞLANTI RESMİ	CONNECTEURS CONNETTORI Εικόνα φικς	CONECTORES KOŃCÓWKI PRZYŁĄCZENIOWE STEKKERAFBEELDING	ORDER STOCK	NTK
<p>78</p> 			0256	OZA21-F3
<p>79</p> 			0461	OZA446-E56
<p>80</p> 			0450	OZA446-E55
<p>81</p> 			1779	OZA324-L1

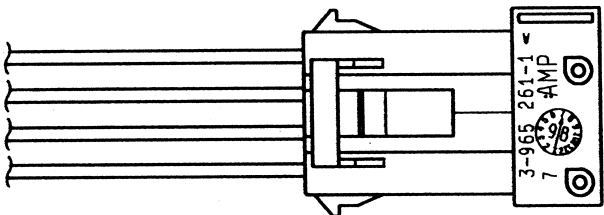
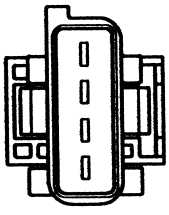
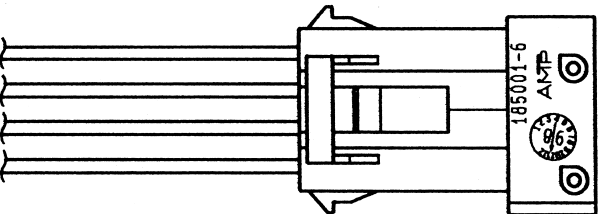
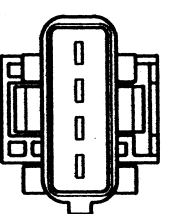
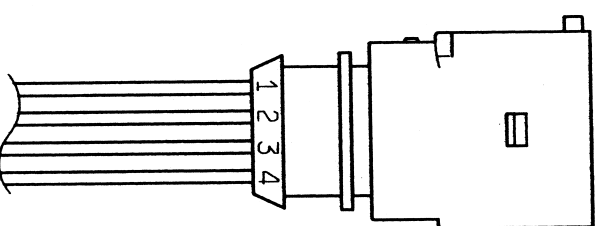
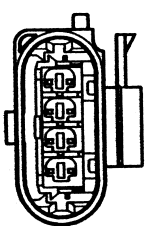
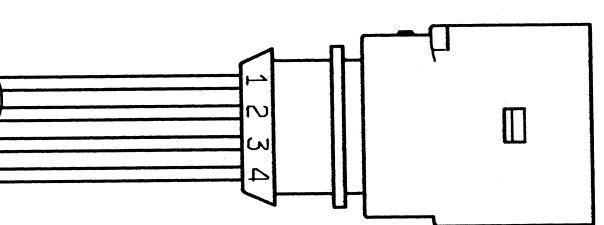
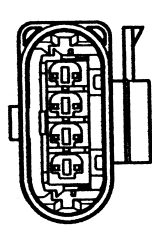
STECKERABBILDUNG CONNECTORS Вид штекера BAĞLANTI RESMİ	CONNECTEURS CONNETTORI Εικόνα φις	CONECTORES KOŃCÓWKI PRZYŁĄCZENIOWE STEKKERAFBEELDING	ORDER STOCK	NTK
82 			1813	OZA341-PG5
			1814	OZA341-PG6
			1815	OZA341-PG7
			1816	OZA341-PG8
			1818	OZA538-PG1
			1819	OZA538-PG2
83 			1852	OZA495-PG2
			1853	OZA495-PG3
84 			1783	OZA510-AU2
85 			1784	OZA510-AU3
			1884	OZA510-V11
			1776	OZA532-V3

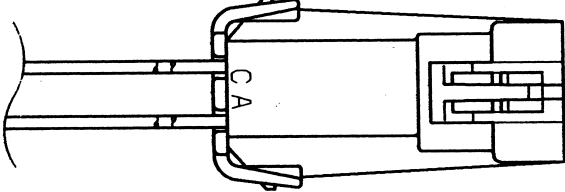
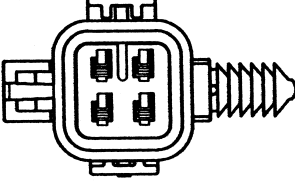
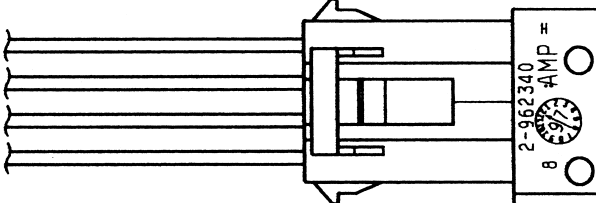
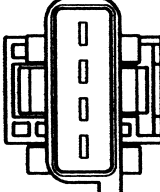
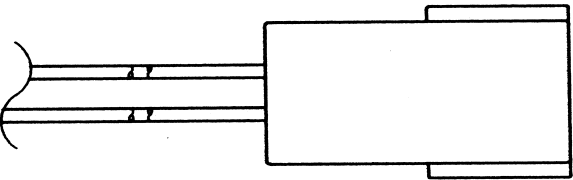
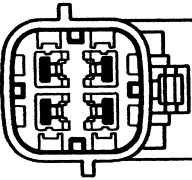
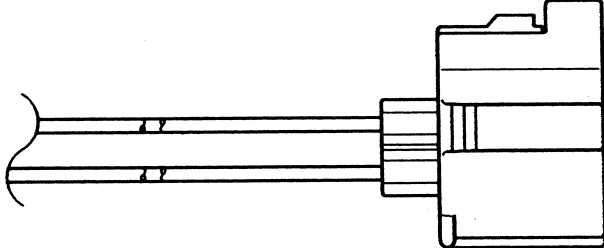
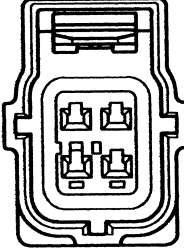
STECKERABBILDUNG CONNECTORS Вид штекера BAĞLANTI RESMİ	CONNECTEURS CONNETTORI Εικόνα φικς	CONECTORES KOŃCÓWKI PRZYŁĄCZENIOWE STEKKERAFBEELDING	ORDER STOCK	NTK
86 		1862	OZA531-GM1	
		1869	OZA531-GM6	
		1870	OZA531-GM7	
		1753	OZA583-GM1	
87 		1891	OZA531-GM16	
		1754	OZA583-GM2	
88 		1857	OZA544-R1	
89 		1836	OZA571-C10	

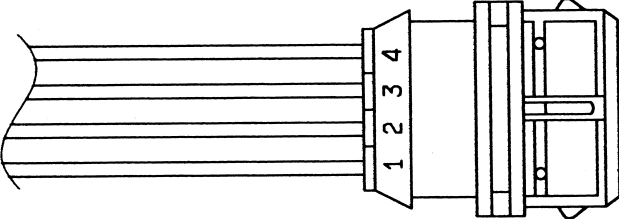
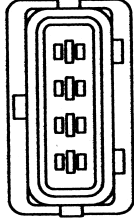
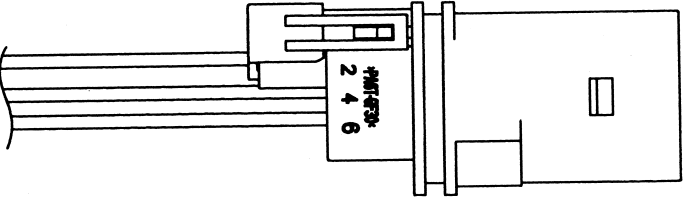
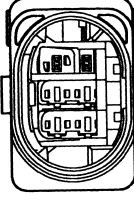
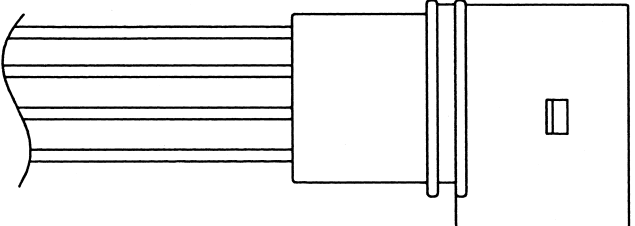
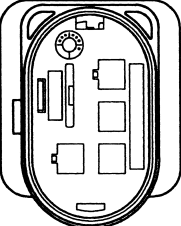
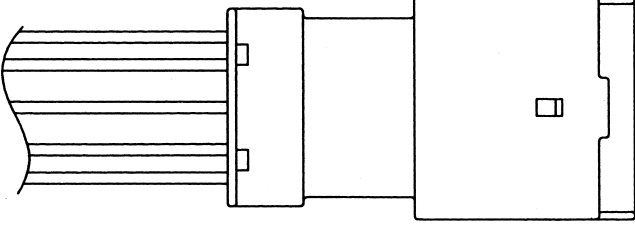
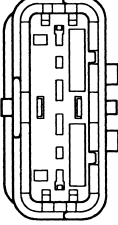
STECKERABBILDUNG CONNECTORS Вид штекера BAĞLANTI RESMİ	CONNECTEURS CONNETTORI Εικόνα φίς	CONECTORES KOŃCÓWKI PRZYŁĄCZENIOWE STEKKERAFBEELDING	ORDER STOCK	NTK
90 			1785	OTA4N-5D1
91 			1772	LZA07-AU1
92 			1851	LZA07-V1
93 			1868	LZA07-V2
			1825	LZA11-V1
			1774	LZA11-V2
			1829	LZA11-V3
			1842	LZA11-V4

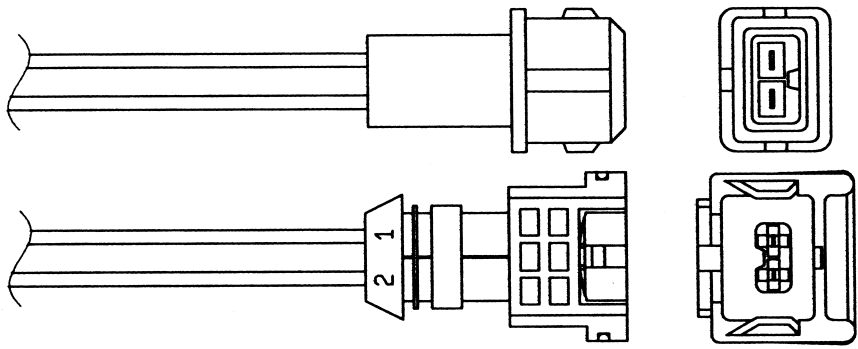
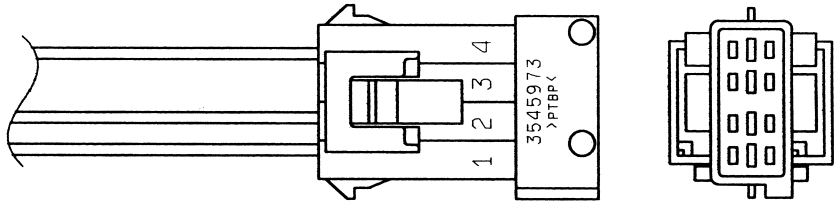
STECKERABBILDUNG CONNECTORS Вид штекера BAĞLANTI RESMİ	CONNECTEURS CONNETTORI Εικόνα φικς	CONECTORES KOŃCÓWKI PRZYŁĄCZENIOWE STEKKERAFBEELDING	ORDER STOCK	NTK
94 			1755	OTA4N-5A1
95 			1773	OTA4F-3C1

PS \longleftrightarrow kW

PS	kW	kW	PS
1	0,736	1	1,360
30	22,065	20	27,192
35	25,742	25	33,991
40	29,420	30	40,789
45	33,097	35	47,587
50	36,775	40	54,385
55	40,452	45	61,183
60	44,130	50	67,981
65	47,807	55	74,779
70	51,485	60	81,577
75	55,162	65	88,375
80	58,840	70	95,173
85	62,517	75	101,972
90	66,195	80	108,770
95	69,872	85	115,568
100	73,550	90	122,366
105	77,227	95	129,162
110	80,905	100	135,962
115	84,582	105	142,760
120	88,260	110	149,558
125	91,937	115	156,356
130	95,615	120	163,154
135	99,292	125	169,953
140	102,970	130	176,751
145	106,647	135	183,549
150	110,325	140	190,347
155	114,002	145	197,145
160	117,680	150	203,943
165	121,357	155	210,741
170	125,035	160	217,539
175	128,712	165	224,337
180	132,390	170	231,135
185	136,067	175	237,934
190	139,745	180	244,732
195	143,422	185	251,530
200	147,100	190	258,328
205	150,777	195	265,126
210	154,455	200	271,924
215	158,132	205	278,722
220	161,810	210	285,520
225	165,487	215	292,318
230	169,165	220	299,116
235	172,842	225	305,915
240	176,520	230	312,713
245	180,197	235	319,511
250	183,875	240	326,309
255	187,552	245	333,107
260	191,230	250	339,905
265	194,907	255	346,703
270	198,585	260	353,501
275	202,263	265	360,299

HANDLING INSTRUCTIONS

- Read enclosed instructions before installation.
- Do not use sensor if it has been dropped.
- Do not store under high temperature and/or high humidity conditions.

INSTALLATION INSTRUCTIONS

- This sensor is designed for the use in automobiles only.
- Use the correct part number as listed in the application catalogue.
- Do not use sensor if it has been dropped.
- Remove protection cap just prior to installation.
- Firstly install sensor body ensuring lead wire is not twisted or bent.
- Do not use impact wrench or socket type wrench to install sensor.

- **M18 sensors - install finger tight then 1/2 - 3/4 turn with a wrench (35 ~ 45 Nm).**

- **M12 sensors - install finger tight then 3/4 - 1 turn with a wrench (18 ~ 23 Nm).**

- Then connect and route lead wire as originally installed.
- Do not allow lead wire to touch exhaust manifold or any other hot component.
- Do not expose this product to water, oil, windshield cleaner, anti-corrosion oil, grease, terminal cleaner etc.
- Do not use leaded fuels, silicone or metal based additives.