

**For JBS Units without On-board Door Lock Relays:**

Requires  
(1) 778 or  
(2) 775's

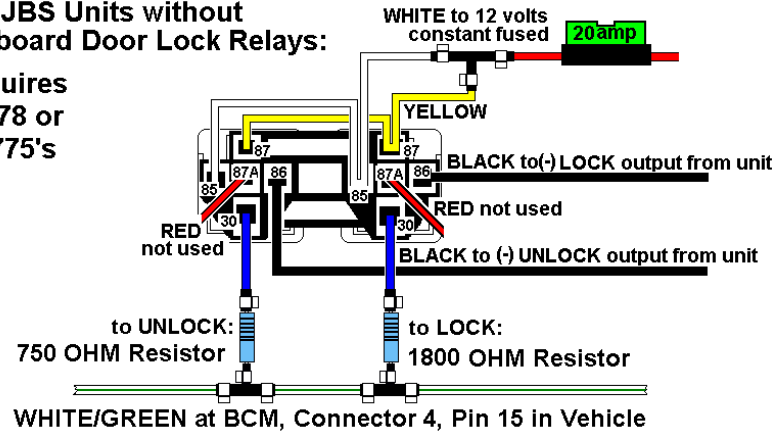

**For JBS Units with On-board Door Lock Relays:**

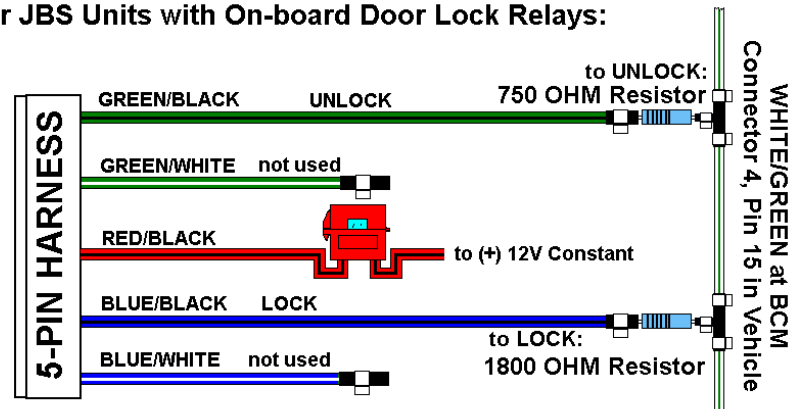

NOTE: Connect the RED WITH BLACK STRIPE to (+) 12V Constant

**KE-100, KE-150 and 1702**

