

CHRYSLER (+) Positive Factory Disarm wire Diagram and Resistor Value Chart:

FACTORY (+) POSITIVE Disarm wire in Vehicle

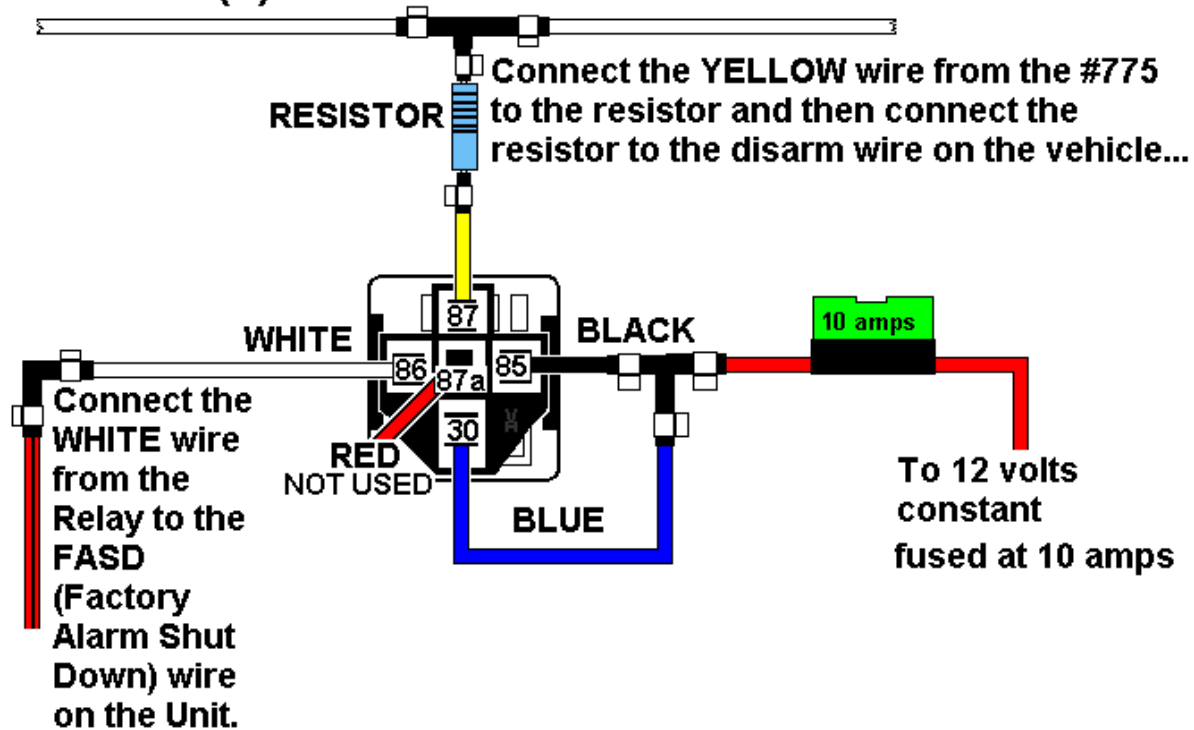

YEAR and MODEL	RESISTOR VALUE	LOCATION
99-04 Chrysler 300M	680 Ohm	LIGHT GREEN/ORANGE in Drivers Kick, Door Har.
95-00 Chrysler Cirrus	470 Ohm	GREEN/ORANGE in Kick Panel or at BCM
99-Up Chrysler Concorde	680 Ohm	LIGHT GREEN/ORANGE in Drivers Kick, Door Har.
99-01 Chrysler LHS	680 Ohm	LIGHT GREEN/ORANGE in Drivers Kick
01-Up Chrysler Sebring Sedan	750 Ohm	LIGHT GREEN/ORANGE @ BCM, Conn. C4, Pin 1
96-00 Chrysler Sebring Conv.	470 Ohm	LIGHT GREEN/ORANGE in Drivers Kick Panel above hood release
01-Up Chrysler Sebring Conv.	750 Ohm	LIGHT GREEN/ORANGE @ BCM, Conn. 4, Pin 4
99-Up Dodge Intrepid	680 Ohm	LIGHT GREEN/ORANGE in Drivers Kick, Door Har.
95-00 Dodge Stratus	470 Ohm	GREEN/ORANGE in Kick Panel or at BCM
01-Up Dodge Stratus Sedan	750 Ohm	LIGHT GREEN/ORANGE @ BCM, Conn. 4, Pin 4
96-00 Plymouth Breeze	470 Ohm	GREEN/ORANGE in Kick Panel or at BCM