

BEC

Student Learning Guide

Course Introduction



**Automotive
Electrical Course**

KIA

SERVICE TRAINING



Welcome to Kia Automotive Electrical

- Electrical principles and hands-on diagnostics for Kia Technicians
- Review of available resources
- Course length is 3 days

AEC-1

This three day course provides an opportunity for hands-on electrical diagnosis practice.

During this course, you will:

- Analyze automotive circuits using circuit diagrams.
- Learn to use the Kia 5-Step Troubleshooting Process to locate faults.
- Gain experience using the DVOM.
- Identify normal system operation of electrical system components.
- Inspect for normal operation of the vehicle's basic electrical systems.

COURSE GOAL

To provide the Kia technician with the skills and knowledge required to diagnose and repair a vehicle that has an electrical system malfunction.

AEC-2

PREREQUISITES

None



Modular format will help you focus your efforts in the areas that are of the most value to you.

AEC-3

1. Student Learning Guide and Workbook:
 - Explains theory
 - Can be used for self study
2. Guided Practice
 - Provides hands-on experience
 - Helps develop troubleshooting skills

AEC-4

MODULAR FORMAT

As a Kia service professional, you understand the importance of staying current with today's complex automotive technology. The amount of training that a technician needs depends on factors like technical background, product knowledge and practical experience. To meet your needs, we have developed a modular training system to help you focus your efforts in the areas that are of the most value to you.

TWO TYPES OF MODULES

1. Student Learning Guide and Workbook

This module explains subjects from basic concepts to the most complex technology we offer. Obtaining a working knowledge of any system or component is a prerequisite to effectively diagnose system malfunctions. There may also be classroom exercises that you will complete as a group.

2. Guided Practice

This module provides hands-on experience that will build on the theory and diagnosis topics discussed in the classroom.

These modules will also help develop your troubleshooting skills. This course will involve the use of service manuals, ETMs, technical service bulletins, newsletters and other resources as an integral approach to your overall diagnostic strategy.



VIDEO

When you see this symbol, view the appropriate video segment for important concepts or procedures.

ACTIVITY

Activities support critical learning objectives. Performing these procedures will help you master the material.

REFERENCE

This symbol shows when you must refer to additional publications to complete the questions or module activity.

FEEDBACK

Most modules contain a Self-Test or an Instructor Sign-Off to give you feedback on your strengths and weaknesses. Gauge your level of expertise by your ability to answer the questions and instructor's feedback. Review appropriate areas as needed.

AEC-5

MODULE SYMBOLS

Several symbols have been designed to keep you on track as you complete each module. These symbols are shown in the illustration above.



TIME	LOCATION	INST. TYPE	SUBJECT MATTER
8:00-8:30	Classroom	Discussion	<u>Course Introductions</u>
8:30-9:00	Classroom	Video	<u>Electrical Fundamentals</u>
9:00-10:00	Classroom	Discussion	<u>Electrical Fundamentals</u>
10:00-10:15	BREAK		
10:15-10:30	Classroom	Video	<u>Introduction to Multimeters</u>
10:30-11:30	Classroom	Discussion/Activity	<u>Introduction to Multimeters</u>
11:30-12:30	LUNCH		
12:30-2:30	Classroom	Discussion/Activity	<u>Electrical Circuits</u>
2:30-2:45	BREAK		
2:45-4:00	Classroom	Discussion/Activity	<u>Electrical Circuits</u>
4:00-4:30	Classroom	Evaluation	<u>Review / Day 1 Test</u>

AEC-6

TIME	LOCATION	INST. TYPE	SUBJECT MATTER
8:00-9:30	Classroom	Discussion/Activity	<u>Electrical Circuits</u>
9:30-9:45	BREAK		
9:45-12:00	Classroom	Discussion/Activity	<u>Electrical Circuits</u>
12:00-1:00	LUNCH		
1:00-1:45	Classroom	Video	<u>Electrical Diagnosis</u>
1:45-2:45	Classroom/Shop	Discussion/Activity	<u>Electrical Diagnosis</u>
2:45-3:00	BREAK		
3:00-4:00	Classroom	Discussion/Activity	<u>Electrical Diagnosis</u>
4:00-4:30	Classroom	Evaluation	<u>Review / Day 2 Test</u>

AEC-7



TIME	LOCATION	INST. TYPE	SUBJECT MATTER
8:00-8:15	Classroom	Video	<u>Electrical Repairs</u>
8:15-9:30	Classroom/Shop	Discussion/Activity	<u>Electrical Repairs</u>
9:30-9:45	BREAK		
9:45-10:45	Classroom	Discussion/Activity	<u>Electrical Repairs</u>
10:45-11:15	Classroom	Video	<u>Battery, Charging and Starting Systems</u>
11:15-12:00	Classroom/Shop	Discussion/Activity	<u>Battery, Charging and Starting Systems</u>
12:00-1:00	LUNCH		
1:00-2:30	Classroom/Shop	Discussion/Activity	<u>Battery, Charging and Starting Systems</u>
2:30-2:45	BREAK		
2:45-4:00	Classroom/Shop	Discussion/Activity	<u>Battery, Charging and Starting Systems</u>
4:00-4:30	Classroom	Evaluation	<u>Review / Final Test</u>

AEC-8

- Take notes and make drawings
 - Work as a team
 - Learn from mistakes
 - Ask questions
 - Be an active participant
- AEC-9

GETTING THE MOST OUT OF THE COURSE

Use the course materials in any way that will help you remember the material. Make notes or drawings on these materials to help you remember details.

One of Kia’s main goals is to provide as much individual instruction as possible. If you do not understand something in the classroom, ask your instructor to clarify the point.

During hands-on practice sessions, you will often be part of a working team. You will only learn from the experience if you actively participate.



This training course is an opportunity to learn advanced skills successfully in a controlled environment under the guidance of a trained Kia instructor. Have a good experience here, and return to your dealership with confidence in your own abilities as a trained Kia professional.

Guided Practice = 45%
Day 1 Test = 10%
Day 2 Test = 10%
+ Final test = 25%
<hr/>
+ Class participation = 10%
Total = 100%
80% required for course credit
AEC-10

COURSE CREDIT

Course credit will be granted by a Kia Service Training Instructor when all of the criteria for course completion has been met.

Because our technical training is performance-based, hands-on practice will make up 45% of your course credit. Each Guided Practice module lists specific performance objectives that are the basis for scoring. The instructor will observe and evaluate your performance, coaching you when necessary.

Additional factors that may affect this score are safe and appropriate use of tools and equipment and following written and verbal instructions.

Each Guided Practice Module is assigned a relative "point" value, depending on the difficulty of the material.

The Day 1 and Day 2 tests are 10% each. The Final Test is 25% of your grade.

The instructor will evaluate the degree to which you contribute to discussions, offer your experience, or simply ask questions about something you don't understand. Participation also takes into account your professional conduct and working with teammates during classroom and shop practice activities. This counts for 10% of your course credit.

The sum of the above scores will determine your course achievement performance. A minimum score of 80% is required for course credit.



A series of horizontal lines for writing, with a large, faint, diagonal watermark reading "NOTES" overlaid across the center of the page.



NOTES



WE SUPPORT
VOLUNTARY TECHNICIAN
CERTIFICATION THROUGH

National Institute for
**AUTOMOTIVE
SERVICE
EXCELLENCE**

No part of this publication may be reproduced, stored electronically, or transmitted in any form or by any means without prior written approval from Kia Motors America, Inc. KMA reserves the right to make changes in the descriptions, specifications or procedures without prior notice or obligation.

Copyright © 1999 Kia Motors America, Inc. Corporate Service Training Department



EF1

Student Learning Guide

Electrical Fundamentals

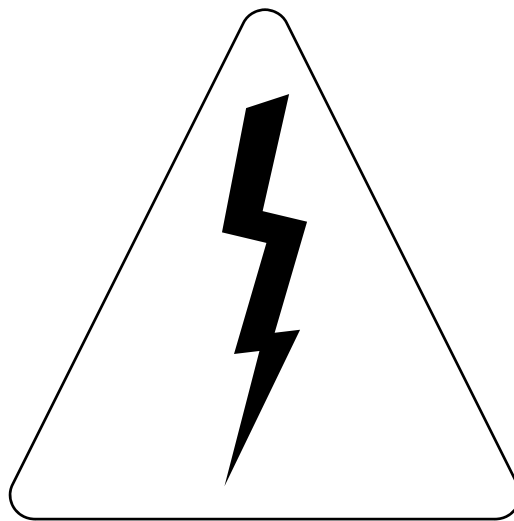

**Automotive
Electrical Course**



S E R V I C E T R A I N I N G



Each year there is an increased use of electronics in the automobile. With the emphasis put on fast and accurate diagnosis it is important for the technician to understand what electricity is and how it works.

LEARNING OBJECTIVES

After successfully completing this module, you should be able to:

- Explain what electricity is and how it works
- Define voltage, amperage, resistance and watts
- Define magnetism, inductance, capacitance and impedance

EF1-1

MODULE DIRECTIONS

Carefully read this material. Study each illustration as you read the material. Feel free to ask questions any time something is not clear. Be sure to answer the questions in the spaces provided as you perform the activities.

THINGS YOU WILL NEED

- The materials in this module
- The electrical project board
- A digital multimeter

- First recorded in 600 BC
- Some materials when rubbed together will attract other materials
- 18th century discovery found that like charges repel and opposite charges attract

EF1-2

- Benjamin Franklin proves that lightning is a form of electricity - mid 1800's
- Electrical current is thought to flow from positive to negative (Conventional Current Flow)
- The electron is discovered in 1897

EF1-3

- A form of energy where electrons move from one atom to another
- Exists when a voltage source creates a current flow by pushing electrons with enough force to overcome the resistance of the circuit
- Voltage, current and resistance are the three basic elements of a circuit
- Invisible, but effects can be seen

EF1-4

DISCOVERY OF ELECTRICITY

The first recording of electricity was around 600 BC. It was found that by rubbing certain substances they would attract lighter objects to them. Later in the 18th century it was discovered that there were two kinds of forces, or charges, caused by rubbing certain materials. It was found that like charges would repel and opposite charges would attract.

THE FAMOUS KITE EXPERIMENT

In the mid 1800's Benjamin Franklin proved that lightning was a form of electricity. He flew a kite into a thunderstorm and found that sparks jumped to the ground from a metal key attached to the wet string.

An assumption was made that there was current coming down the string from a high level of energy to a lower level. The high level of energy was called **positive** and the low level of energy was called **negative**. The assumption that electrical current flowed from positive to negative was accepted until 1897 when the discovery of the electron proved that it was actually the electrons, or negative particles of electricity, that move through a circuit.

WHAT IS ELECTRICITY?

Electricity is a form of energy where electrons move from one atom to another. The movement of these electrons can be explained by the **Electron Theory**. Electricity exists when a voltage source creates a current flow by pushing electrons with enough force to overcome the resistance of the circuit. Voltage, current and resistance are the three basic elements of a circuit. Electricity itself is invisible but its effects can be seen in the forms of light, heat, noise and motion. Examples: We can see the light that a lamp gives off. We can see a motor turn. We can hear the buzzer's sound and we can feel the heat from an electric heater element.

- All matter is made up of atoms
- Each atom has a nucleus surrounded by orbiting electrons
- The outer orbiting electrons can move to neighboring atoms when the atom becomes unbalanced
- The movement of electrons from atom to atom is electricity

EF1-5

ELECTRON THEORY

The Electron Theory states that all matter (solid, liquid or gas) is made up of atoms joined together. Each atom is made up of a nucleus and electrons. The electrons orbit around the nucleus. The outer orbiting electrons can move from one atom to another when the number of electrons in the atom become unbalanced. This movement of electrons is known as electricity.

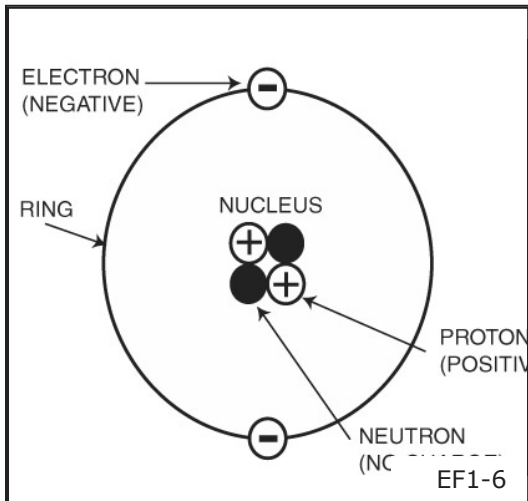

THE ATOM

The atom is like a tiny solar system. The atom has a nucleus at its center which is made up of protons and neutrons. The protons are positively charged. The neutrons have no electrical charge but are of the same weight as the protons. Orbiting at a very high rate of speed around the nucleus are negatively charged electrons. When the number of electrons equals the number of protons the atom is balanced. These electrons weigh about 1/1845 as much as a proton. Energy within the atom causes the electrons to spin around the nucleus in rings or shells. As they spin, centrifugal force pulls the electrons away from the nucleus but an electrostatic force within the nucleus balances the centrifugal force and keeps the electrons at a specific distance from the nucleus. When more energy is added to the atom, such as heat, the electrostatic force within the nucleus decreases and the centrifugal force of the electrons increases. The electrons then move further away from the nucleus until the two forces become equal again.

- Protons have a positive charge
- Neutrons have no charge
- Negatively charged electrons orbit the nucleus
- Combination of electrostatic force and centrifugal force keep the electrons in orbit
- The distance between the electrons and the nucleus is increased when more energy is added to the atom

EF1-7

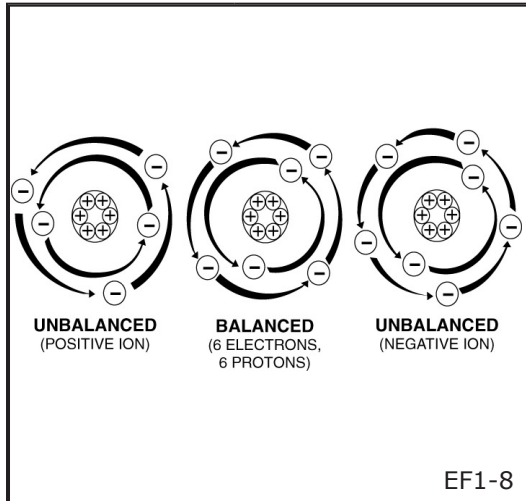

IONS

An electrical force outside the atom can attract electrons from the outer ring and leave the atom in an unbalanced condition. An unbalanced atom is called an ion. When an atom gains an electron and has more electrons than protons it is a negative ion. When an atom loses an electron and has more protons than electrons it is a positive ion and will attract an electron from a nearby balanced atom. The electrons are constantly moving within a material from one atom to another. This causes electron flow.

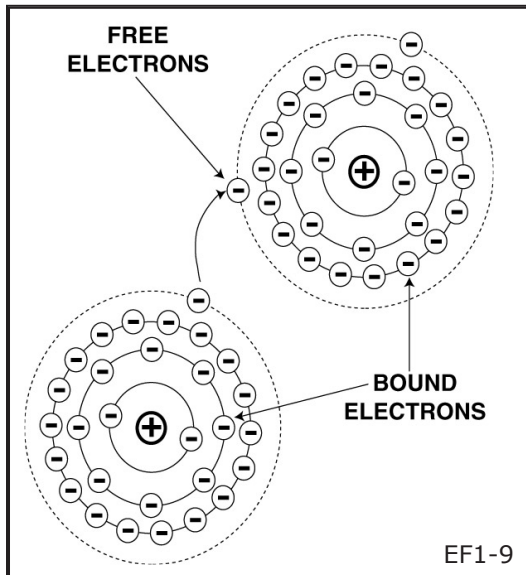

ELECTRON FLOW

The electrons in the outer ring are not as strongly attracted to the protons as the inner rings of electrons. The inner electrons are called **bound electrons** and the outer electrons are called **free electrons**. When a force such as heat, pressure, friction, light, chemical action or magnetic action is applied to the material, the free electrons can move from one atom to the next. Electrical current can be formed by a stream of these free electrons along a conductor.

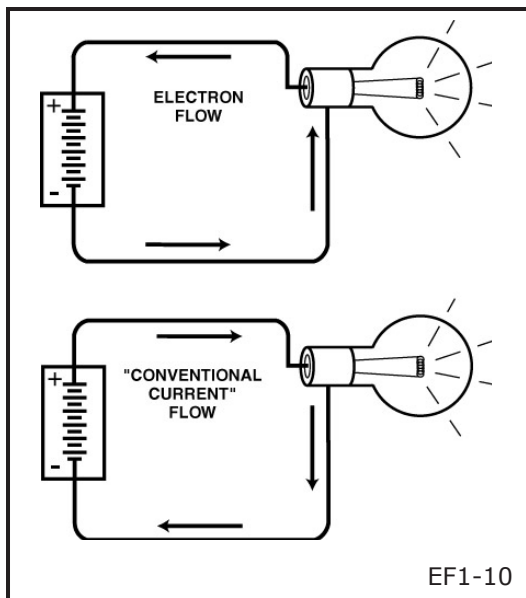

DIRECTION OF FLOW

There are two ways that we can consider the flow of electrical current. The **electron flow** which is from negative to positive and the flow of **conventional current** which, while actually a myth, flows from positive to negative. It is easier to think in terms of conventional current flow since most electrical drawings and semiconductor symbols are marked with arrows indicating the conventional current flow. It is also easier to use the conventional current flow because we can relate the flow of electricity to the rules of hydraulics in that there is a pressure, flow and opposition.



Quantity

- Basic unit is the coulomb
- One coulomb = 6.28×10^{18} electrons
- Symbol for quantity is Q

Flow

- Basic unit is the ampere
- The flow of one coulomb past a given point in one second
- Normally called current
- Symbol for current is I (Intensity)

Pressure

- Basic unit is the volt
- Amount of pressure required to force one ampere of flow through one ohm of resistance.
- Symbol for voltage is E (Electromotive force)

Opposition

- Basic unit is the ohm
- The resistance that opposes current flow
- Changes electrical energy into another form of energy eg: heat, light or motion
- The symbol for resistance is R

Power

- Basic unit is the watt
- The amount of electrical power used when one amp of current flows under a pressure of one volt
- The end result of electricity
- The symbol for power is P

EF1-11 thru EF1-16

MEASUREMENT OF ELECTRICITY

Quantity

The electron is such a small particle of electricity that a very large quantity are required to have a measurable unit. The basic unit of electrical quantity is the **coulomb**. A coulomb is equal to 6.28 billion, billion electrons (6.28×10^{18}). The symbol for quantity is **Q**.

Flow

When one coulomb flows past a given point in one second, there is a flow of one **ampere**, or one amp. It will be the same whether we think of electron flow or conventional current. This flow is normally called current and its symbol is **I** for intensity.

Pressure

The **volt** is the standard unit of electrical pressure and is the amount of pressure required to force one ampere of flow through one ohm of resistance. The symbol for voltage (electrical pressure) is **E** for electromotive force.

Opposition

Every electrical circuit or component has resistance. Resistance is what opposes current flow. It is this resistance that changes the electrical energy into another form of energy such as heat, light or motion. There are five factors that affect the resistance of a conductor - the conductor's type of material, length, diameter, temperature and physical condition. The standard unit of resistance is the **ohm**. One ohm is the resistance through which a pressure of one volt can force a flow of one ampere. The symbol for resistance is **R**.

Power

The end result of electricity is power. The **watt** is the unit of electrical power. One watt is the amount of power used when one amp of current flows under a pressure of one volt. The symbol for power is **P**.

- Magnetism is an invisible force
 - Causes certain metals to repel or attract
 - Magnets have a field/flux that loops from the N pole to the S pole
 - Like poles repel and unlike poles attract
- EF1-17

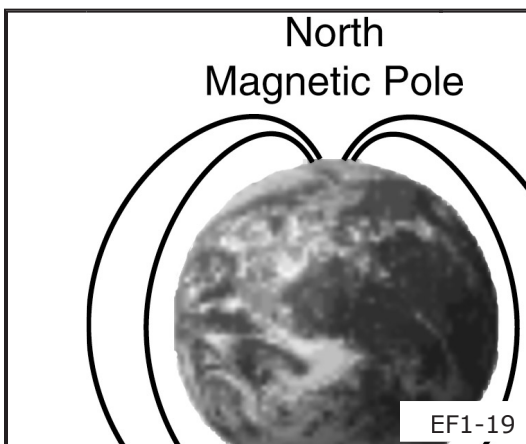
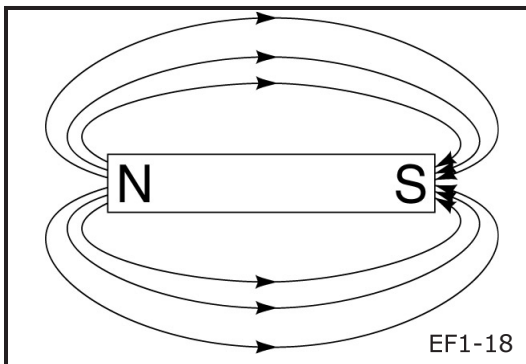

MAGNETISM / ELECTROMAGNETISM

Magnetism

Like electricity, you cannot see magnetism, but you can feel its effects. It is an invisible force that acts on certain types of metals, such as iron and steel, causing them to pull together or push away from each other.

There is a definite area around every magnet where the magnet force exerts its power. This power is called the magnetic field or flux. The further away from the magnet, the weaker the field. The magnetic force always completes a loop that leaves one end of the magnet (North-seeking) and re-enters the other end (South-seeking). These ends of the magnet are the magnetic poles and are the two strongest areas of the field. Because the magnet is polarized, unlike poles attract and like poles repel.

The earth itself is an extremely large magnet with its magnetic lines of flux extending 50,000 miles from its surface. If a bar magnet is suspended by a string the earth's magnetic field will cause the magnet to orient itself in a north-south direction. We are able to use this phenomenon to make a compass.

- A weak magnetic field with no polarity surrounds a conductor with current flowing through it
- If the conductor is coiled the field becomes stronger and now has a north and south pole
- The coil's magnetic field is directly proportional to the current and the number of turns on the coil
- An iron rod down the middle of the coil strengthens the magnetic field

EF1-20

Electromagnetism

In the early 1800s, the relationship between magnetism and electricity was discovered when it was found that the needle of a magnetic compass was deflected when it was placed near a current carrying conductor.

This deflection was caused by an invisible magnetic field that surrounds the conductor when an electrical current flows through it. This magnetic field is relatively weak and has no polarity. But if the wire is wound into a coil the field becomes stronger and has a definite north and south pole. The strength of the coil's magnetic field is directly proportional to the current and the number of turns on the coil. It was soon discovered that the magnetic field could be made even stronger by placing an iron rod down the middle of the coil.

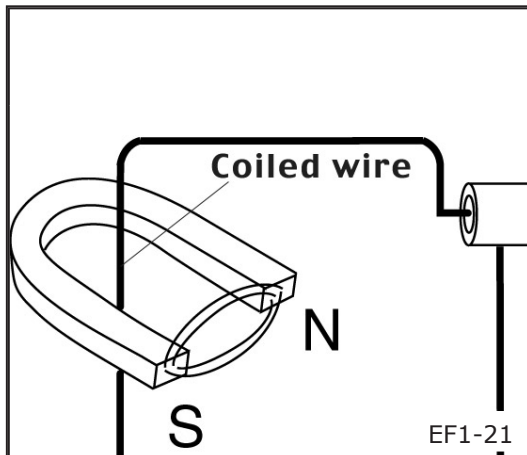

EF1-21

INDUCTANCE

Just as electric currents can produce magnetic fields, so too can magnets produce electric currents. If a magnet is moved near a coil of wire a current is generated in the wire. A current can also be generated if the coil of wire is moved near the magnet. The magnetic lines of flux passing through the conductor forces the electrons to flow through the conductor. The amount of electricity generated depends on the rate at which the lines of flux are cut. The rate can be increased by increasing the number of lines of flux by making the magnet stronger, or by moving the conductor through the lines of flux faster. This principle is used in the alternator to recharge the battery and provide the vehicle with the electricity it needs to operate.

- Capacitance is the storage of an electrical charge
- Capacitors consist of two parallel conductors separated by a dielectric
- When DC is applied to the capacitor the dielectric stores the charge until a path is provided for the current to flow
- Capacitors block the flow of DC
- Capacitors seem to pass AC; the current constantly rises and falls so the capacitor is constantly being charged or discharged

EF1-22

CAPACITANCE

Conductors are able to pass electrical current because the electrons within their atoms are loosely held in orbit. Insulators block the flow of current because their electrons are held tightly within the atom. In certain types of insulators called dielectrics the electrons can be pulled into a distorted orbit. This permits a voltage to exist across the dielectric or you could say the storage of an electrical charge. Some materials used as dielectrics are: waxed paper, glass, mica, oil and air.

Capacitors are made up of two parallel conducting plates separated by a dielectric. When a DC voltage is applied to the terminals of the capacitor the build up of electrons on the negative plate distorts the orbits of the dielectric's electrons in the direction of the positive plate causing the capacitor to become charged. If the voltage source is removed the charge still remains. If a path for the current is provided outside the capacitor the current will then flow from the capacitor discharging it. Capacitors block the flow of direct current since current only flows during the charging or discharging of the capacitor. Capacitors don't pass alternating current but they act like they do. Because the current is constantly rising and falling the capacitor is always either being charged or discharged.

FEEDBACK

SELF-TEST

This self-test will enable you to measure the knowledge that you have gained about Fundamentals of Electricity. Circle the one best answer that completes the statement or answers the question.

1. Electricity is an invisible form of energy where electrons move from one atom to another.
 - a. True
 - b. False
2. Which of the following is a factor that would affect the resistance of a conductor?
 - a. The type of material the conductor is made of.
 - b. The length of the conductor.
 - c. The physical condition of the conductor.
 - d. All of the above.
3. What is the relationship between magnetism and electricity?
 - a. Magnetism is required to make electricity.
 - b. A magnetic field surrounds a conductor with current flowing through it.
 - c. A magnet requires electrical current flow.
 - d. A magnet has the same atomic structure as copper, making it a good conductor.
4. Inductance is the generation of electrical current by rubbing two conductors against each other.
 - a. True
 - b. False



NOTES



NOTES



WE SUPPORT
VOLUNTARY TECHNICIAN
CERTIFICATION THROUGH

National Institute for
**AUTOMOTIVE
SERVICE
EXCELLENCE**

No part of this publication may be reproduced, stored electronically, or transmitted in any form or by any means without prior written approval from Kia Motors America, Inc. KMA reserves the right to make changes in the descriptions, specifications or procedures without prior notice or obligation.

Copyright © 1999 Kia Motors America, Inc. Corporate Service Training Department



IM1

Student Learning Guide

Introduction to Multimeters

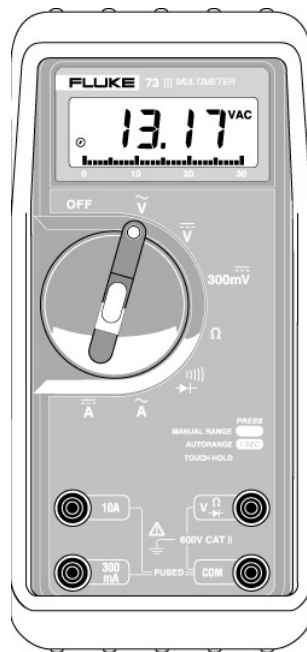

**Automotive
Electrical Course**



S E R V I C E T R A I N I N G



After completing this module, you will be able to identify the uses of multimeters for diagnosing and testing electrical circuits. You will also be able to identify the differences between analog and digital multimeters.

Knowing how to properly use a multimeter will enable you to diagnose and repair Kia automotive electrical problems faster and more effectively.

LEARNING OBJECTIVES

- Identify the precautions necessary to protect the multimeter and the circuit
- Perform unit conversions from whole units to thousandths
- Properly connect the multimeter leads and select the proper function and scale for circuit measurement
- Measure voltage, amperage and resistance

IM1-1

MODULE DIRECTIONS

Carefully read this material. Study each illustration as you read the material. Feel free to ask questions any time something is not clear. Be sure to answer the questions in the activities and at the end of the module.

THINGS YOU WILL NEED

- A digital multimeter
- Electrical project board with accessories

- Multiple functions in one meter
- Basic Functions: voltage, current and resistance
- Advanced Functions: frequency, duty cycle, temperature and oscilloscope

IM1-2

MULTIMETERS

One of the most important and versatile pieces of test equipment you will use in diagnosing electrical system faults is the multimeter. As the name implies these instruments are capable of measuring voltage, current and resistance. More sophisticated models can measure frequency, duty cycle and temperature. Some models, called scope meters, have a built in oscilloscope.

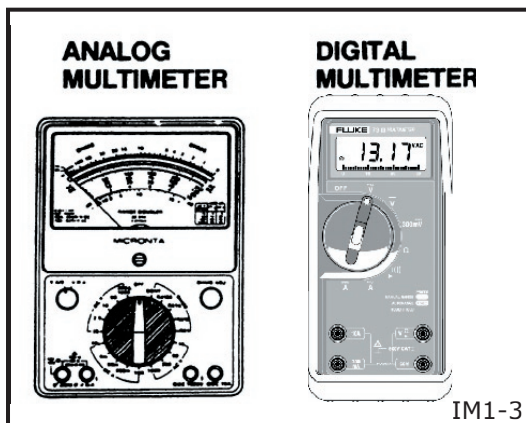

IM1-3

Types of Multimeters

There are two types of multimeters: analog and digital.

Analog meters use a needle and calibrated scale to indicate values.

Digital meters, called DVOMs or DMMs, display the values on a digital display.

- DVOMs are easier to read
- DVOMs have auto ranging
- DVOMs are more accurate
- Low impedance of analog meters can damage solid state circuitry

IM1-4

Analog vs. Digital Meters

The DVOM is recommended over the analog meter for several reasons:

- DVOMs are easier to read.
- Most DVOMs have auto-ranging.
- DVOMs are generally more accurate because their high impedance circuitry does not take power from the circuit.
- The low impedance, or internal resistance, of analog meters can cause inaccurate readings and can damage solid state circuits.

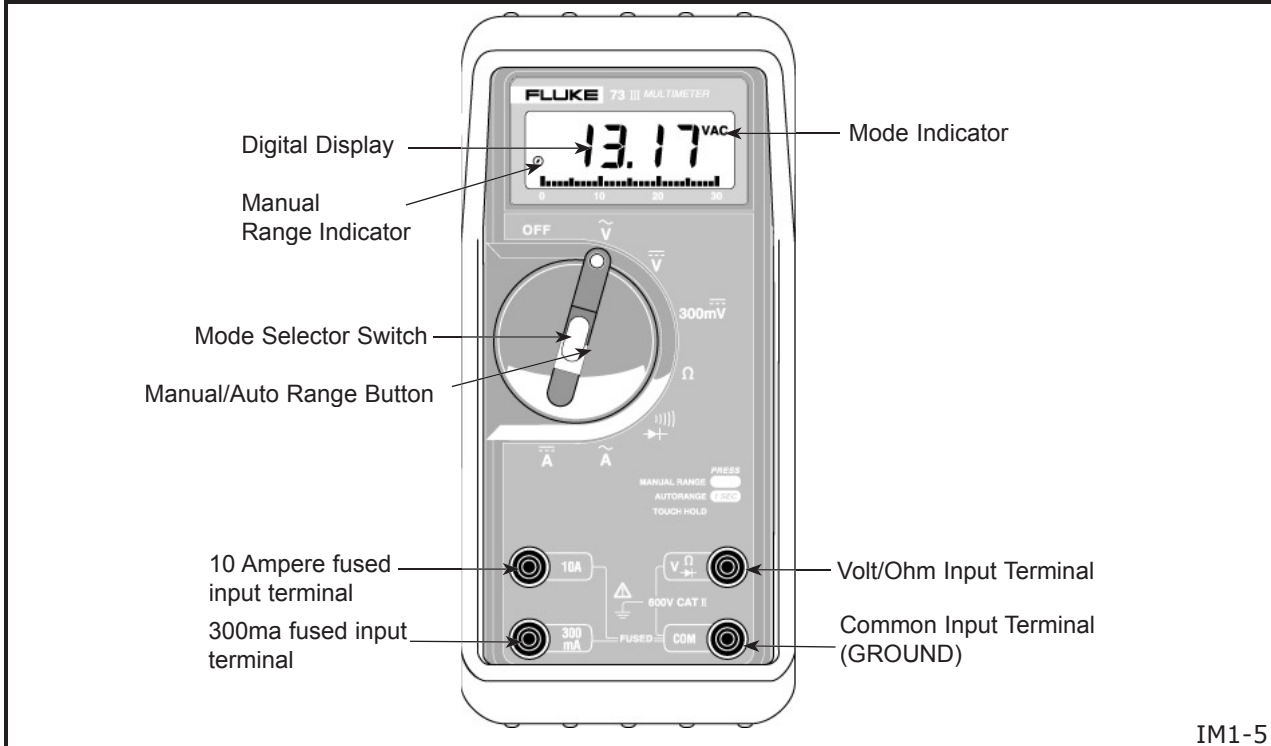

METER SETUP

1. Connect the test leads to the proper jacks.
2. Select the proper range and function.
3. Ensure that you understand what is being shown in the digital display.

IM1-6

SETTING UP THE MULTIMETER

Because digital multimeters are designed to measure voltage, current and resistance, you must properly set up the meter to avoid damaging the meter or the circuit and to ensure that you are making an accurate measurement. Since there is a wide variety of meters available, **always read the operator's manual before using the meter.** There are three important steps to follow when using most digital multimeters.

~ or AC = Alternating Current))) = Audible Continuity Test
⋯ or DC = Direct Current	→ = Diode Test
A = Amperes	k = Kilo or thousand
Ω = Ohms	M = Mega or million
V = Volts	m = Milli or one-thousandth
μ = Micro or one-millionth	

IM1-7

Multimeter Symbols

Become familiar with the display symbols used for the different types of measurement and units of measure. The illustration shows the most common symbols.

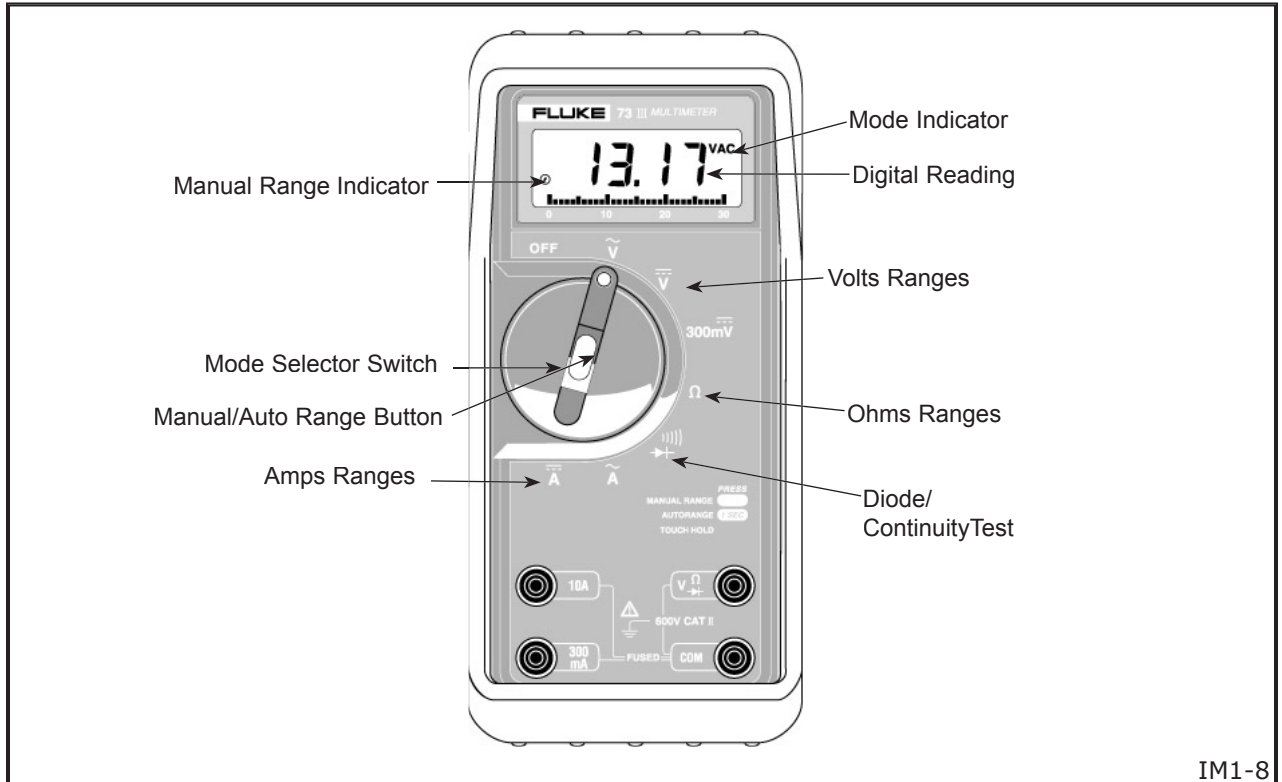

IM1-8

METER FUNCTIONS

Most meters have a rotary selector switch that allows you to set the function and range for the type of reading that you wish to make.

- \tilde{V} Volts AC for measuring alternating current voltages
- \overline{V} Volts DC for measuring direct current voltages
- $300\overline{mV}$ DC millivolts for measuring very low direct current voltages
- Ω Ohms for measuring the resistance in conductors.
-))) Continuity for checking for shorts or opens in conductors
- Diode Test for checking the forward and reverse bias voltage of diodes or other semiconductor junction
- \tilde{A} Amps AC for making series current measurements in alternating current circuits
- \overline{A} Amps DC for making series current measurements in direct current circuits



USING THE MULTIMETER

- Use a test lead adapter from DVOM manufacturer when probing connectors
- Use mating connector or pin when adapter kit is not available
- Probe connectors on operating circuits from rear
- Measure both sides of connector
- Refer to Owner's Manual before using meter.

IM1-9

The most desirable method of probing connectors is by using a test lead adapter from a kit supplied by most DVOM manufacturers. If a kit is not available, use a mating connector or a mating pin from a connector repair kit.

If you need to test a connector while the circuit is operating, always probe the connector from the back side, never puncture the wire insulation. Check the reading on both sides of the connector because dirt and corrosion between contact surfaces can cause electrical problems.

PRECAUTIONS

To ensure that the meter is used safely, follow these instructions:

1. Never use the meter if the meter or test leads look damaged.
2. Be sure the test leads and rotary switch are in the correct positions for the desired measurement.
3. Always insert the meter in the circuit in parallel for voltage and in series for current measurements.
4. Never use the meter in a circuit of higher voltage or amperage than the meter is capable of measuring safely.
5. Always start measuring with the ammeter on the highest scale and work your way down.
6. Never measure resistance in a circuit with power applied (do not forget to discharge all capacitors).
7. Keep your fingers behind the finger guards on the test probes when making measurements.

VERY IMPORTANT!

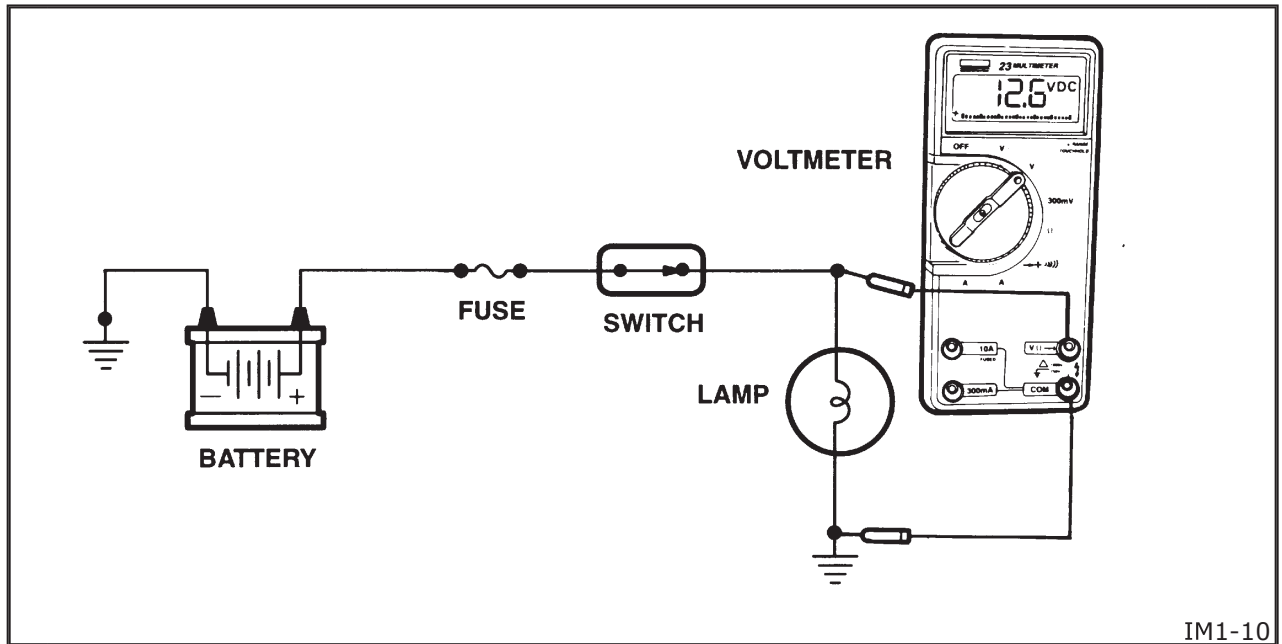

IM1-10

MEASURING VOLTAGE

The *voltmeter* function is used to measure the electrical pressure or voltage difference between two points. A voltmeter reads voltage available from a power source or the voltage drop across a circuit component or connection.

To measure available voltage or voltage drop in a circuit, place the selector switch in the VAC, VDC or mVDC mode. Then connect the meter in parallel with the load device or the circuit with the red lead (positive) connected closest to the positive side of the battery and the black lead (negative) connected to ground or closest to the negative side of the battery.

Unit Conversions

On an automotive electrical circuit, voltage readings are usually displayed as volts or millivolts. Refer to the illustration to make unit conversions.

1 volt = 1000 millivolts

To convert volts to millivolts, move the decimal point three places to the right.

Example: 12 V = 12,000 mV

To convert millivolts to volts, move the decimal point three places to the left.

Example: 120 mV = 0.120 V

IM1-11

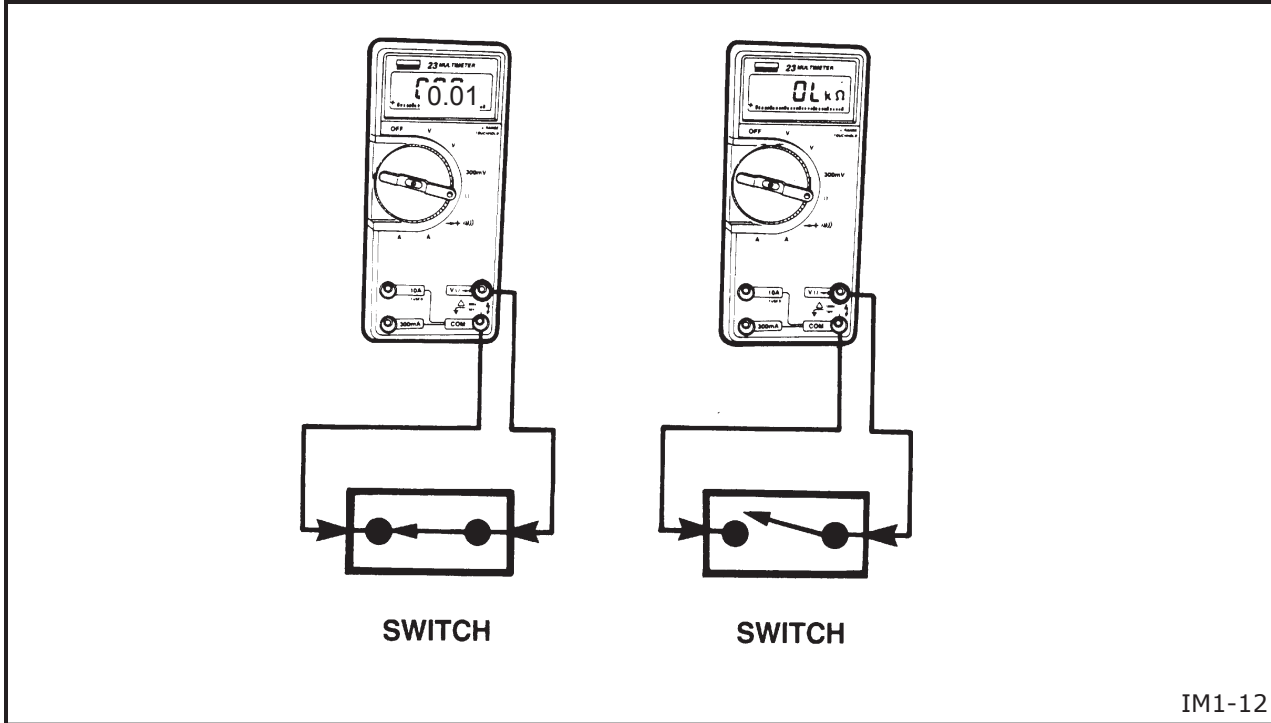

IM1-12

MEASURING RESISTANCE

The *ohmmeter* function is used to check continuity and to measure resistance in a circuit. A zero resistance reading indicates continuity or a short circuit. An out of limits (OL) reading indicates that there is an infinite amount of resistance or an open in a circuit.

To measure continuity or resistance, set the selector switch in the Ω mode. Then connect one test lead to one end of the circuit you are testing and the other test lead to the other end of the circuit. When measuring the resistance of a component, the component must be isolated or disconnected from the rest of the circuit.

Ohmmeters can be connected to the circuit without regard to polarity unless the circuit contains a diode. They have their own internal battery and should never be connected to an operating circuit.

Unit Conversions

Refer to the illustration to make unit conversions.

1 Kilo - ohm = 1000 ohms
 1 Mega - ohm = 1,000,000 ohms

To convert $k\Omega$ to Ω , move the decimal point to the right three places.

Example: $10k\Omega = 10,000 \Omega$

To convert $M\Omega$ to Ω , move the decimal point to the right six places.

Example: $10M\Omega = 10,000,000 \Omega$

IM1-13

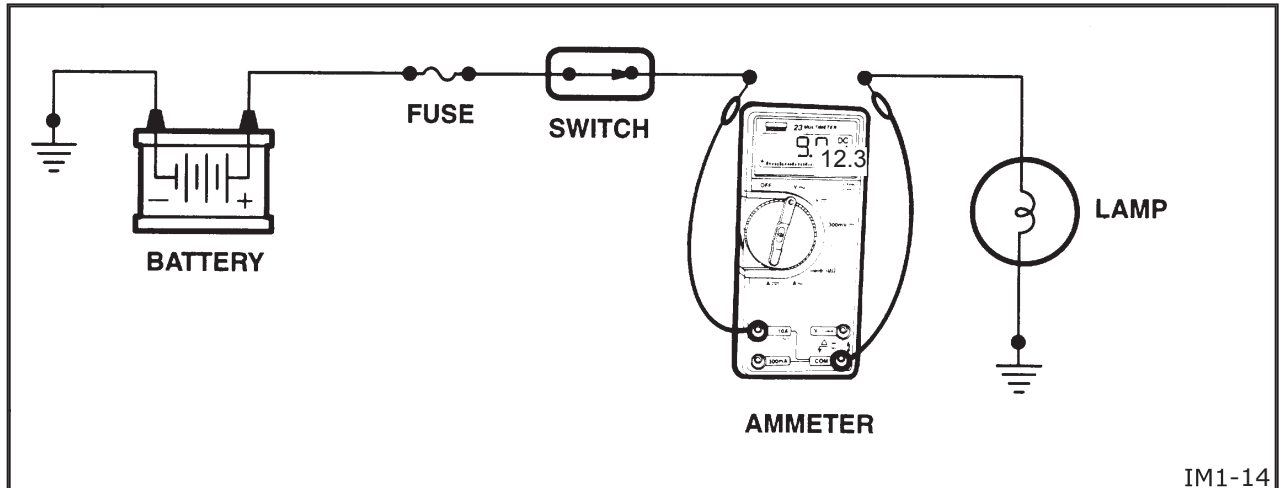

MEASURING CURRENT FLOW

The ammeter function is used to measure the current flow between two points in the circuit.

To measure current flow, remove power from the circuit. Set the selector switch in the AAC or ADC mode and place the red lead in either the 10A or 300mA jack. Then connect the ammeter in series with the circuit or component with the red lead closest to the positive battery terminal. Apply power to the circuit. Compare the current flow (amperage) to the specifications. If the amperage is low, check for high resistance or a discharged battery. If the amperage is high, check for a short or faulty component.

Unit Conversions

Refer to the illustration to learn how to make unit conversions.

1 Amp = 1,000 milliamps

To convert amps to milliamps, move the decimal point three places to the right.

Example: 15 A = 15,000 mA

To convert milliamps to amps, move the decimal place three places to the left.

Example: 1,677 mA = 1.677 A

IM1-15

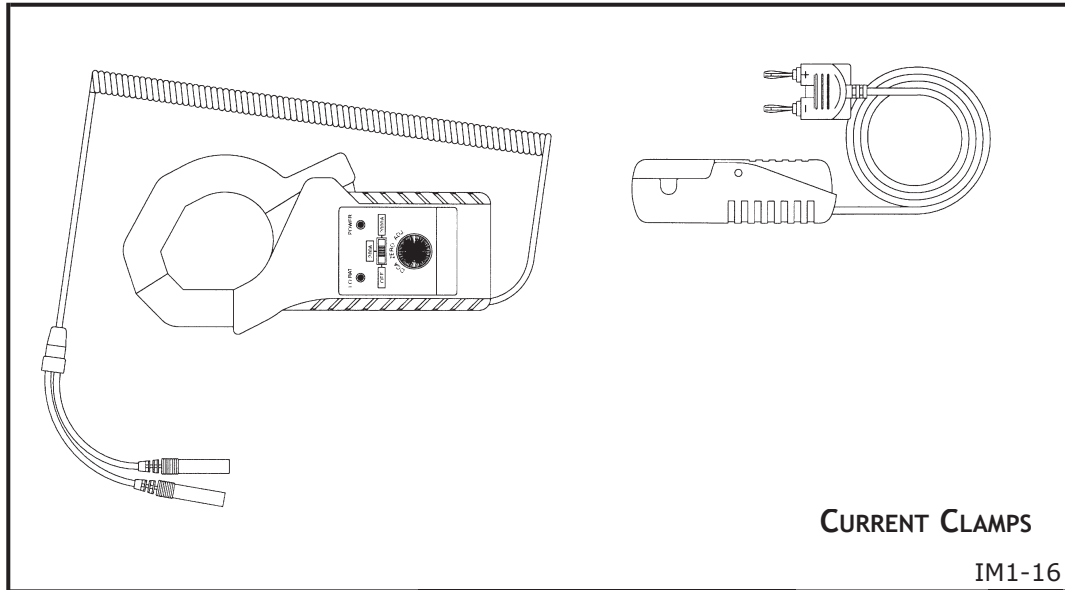

MULTIMETER ACCESSORIES

There are several different types of accessories available for DVOMs. These include test leads, probes and inductive ammeter clamps. In some cases, the multimeter comes in a kit that includes some of these accessories.

Most accessories are available from the manufacturer or at your local electronics store.



ACTIVITY

MULTIMETER ACTIVITIES

Using your assigned multimeter, follow the directions for each activity and answer the questions that describe how you set up the multimeter. Have the instructor check each activity before you move on to the next one.

Activity A

Install the test leads and select the proper range and function to measure 200 millivolts DC.

1. Which jack did you plug the red lead into?

2. Which jack did you plug the black lead into?

3. What is the Mode Selector Switch position?

4. What position is the MANUAL RANGE/
AUTO RANGE switch in?

Activity B

Install the test leads and select the proper range and function to measure 2 kilo-ohms.

1. Which jack did you plug the red lead into?

2. Which jack did you plug the black lead into?

3. What is the Select Switch position?

4. What position is the MANUAL RANGE/
AUTO RANGE switch in?



Activity C

Install the test leads and select the proper range and function to measure 5 amps DC.

1. Which jack did you plug the red lead into?

2. Which jack did you plug the black lead into?

3. What is the Select Switch position?

4. What position is the MANUAL RANGE/
AUTO RANGE switch in?



FEEDBACK

SELF TEST

This self-test will enable you to measure the knowledge that you have gained about using a multimeter. Circle the one best answer that completes the statement or answers the question.

1. To help keep the internal DVOM battery from running down while making resistance checks, make sure that the circuit you are checking has power applied to it.
 - a. True
 - b. False
2. 2 kilo-ohms is equal to _____ohms.
 - a. 020
 - b. 200
 - c. 2,000
 - d. 20,000
3. To measure current flow, how should the meter be connected?
 - a. In series with the circuit
 - b. In parallel with the load device
 - c. Across the power source
 - d. It doesn't matter
4. Most multimeters are capable of measuring up to ___ amps without adding external accessories.
 - a. 5
 - b. 10
 - c. 50
 - d. 100
5. If the red lead is placed in the 10 amp jack, how would 270 milliamps be displayed?
 - a. 270.0
 - b. 27.0
 - c. 2.70
 - d. .270



NOTES



WE SUPPORT
VOLUNTARY TECHNICIAN
CERTIFICATION THROUGH

National Institute for
**AUTOMOTIVE
SERVICE
EXCELLENCE**

No part of this publication may be reproduced, stored electronically, or transmitted in any form or by any means without prior written approval from Kia Motors America, Inc. KMA reserves the right to make changes in the descriptions, specifications or procedures without prior notice or obligation.

Copyright © 1999 Kia Motors America, Inc. Corporate Service Training Department



EC1

Student Learning Guide

Electrical Circuits

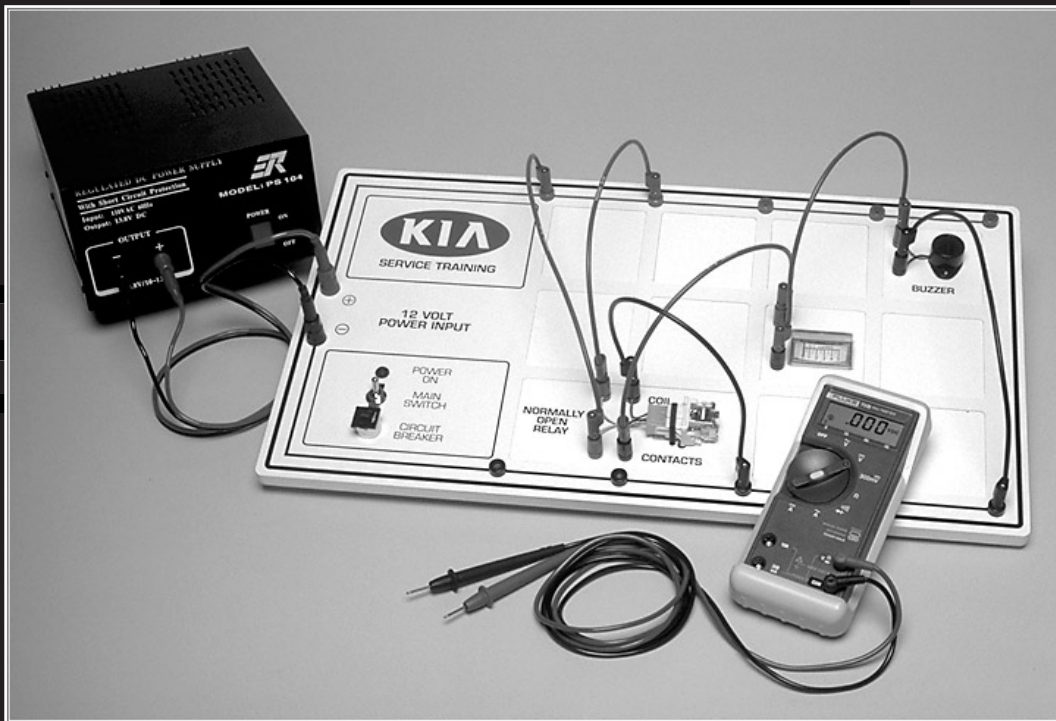

**Automotive
Electrical Course**



S E R V I C E T R A I N I N G



After completing this module, you will be able to identify how different types of automotive electrical circuits are designed to operate and the methods used in controlling electrical behavior in a circuit.

LEARNING OBJECTIVES

To enable you to diagnose and repair Kia automotive electrical problems faster and more effectively.

- Identify circuit elements: power source, load, protection device and ground
- Identify the different types of circuits and circuit control methods
- Determine what is required to make the circuit operate
- Apply the relationship between volts, amps and ohms to diagnose a faulty electrical circuit

EC1-1

MODULE DIRECTIONS

Carefully read this material. Study each illustration as you read the material. Feel free to ask questions any time something is not clear. Be sure to answer the questions at the end of the module.

THINGS YOU WILL NEED

- Module
- Electrical project board and accessories
- DVOM

- A circuit is a path for current to flow
- Electrical behavior in a circuit is influenced by:
 - Design of the circuit
 - Number and types of load devices
 - Size of the conductors
 - Types of control devices

EC1-2

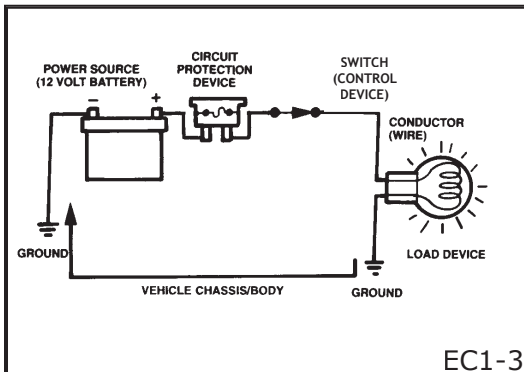

EC1-3

- Voltage source provides pressure to move electrons
- Conductors provide a "controlled path" for current flow
- Load devices convert electrical energy into another form so the circuit can perform useful work
- Intentional opening of protection devices protect the circuit

EC1-4

ELECTRICAL CIRCUITS

The path that electricity flows through is called a circuit. The circuit must form a complete loop from the positive side of the power source to the negative side of the power source. Electrical behavior in a circuit is determined by the design of the circuit, the number and types of load devices, the size of the conductors and the types of control devices used by the circuit.

Electrical Circuit Components

A basic automotive electrical circuit consists of a voltage source (battery, generator), conductors (usually wires or the vehicle body) and one or more load devices that perform some type of useful work such as lamps, motors, etc.

Most electrical circuits have at least one protection device such as a fuse, a circuit breaker or a fusible link and one or more control devices including switches, relays and solid-state devices such as transistors.

Component Descriptions

Voltage (Power) Source - The device that provides the potential or pressure to move electrons through the circuit.

Conductors - Provide a "controlled path" for current flow from and back to the power source.

Load Devices - Convert electrical energy into another form such as heat, light or mechanical energy so the circuit can perform useful work.

Protection Devices - Provide an intentional open circuit when current exceeds specified limits.

Control Devices - can control the amount and direction of current flow through a circuit.



- Turn electrical circuit on or off
- Used on either power side or ground side of circuit

EC1-5

- **Switch**

Mechanical device that opens or closes the circuit

- **Relay**

An electromagnet with a fixed core that attracts a moveable armature

- **Transistor**

Works like a relay but has no moving parts

- **Electronic Control Unit**

Sophisticated switch

Receives signals from sensors then controls actuators

EC1-6

- **Solenoid**

An electromagnet with a moveable core that is pulled into the coil

- **Diode**

A semiconductor device that allows current to flow in only one direction

- **Capacitor**

Can store a small charge which can be released when needed to make a current flow for a short period

EC1-7

Types of Control Devices

The most common types of control devices used in automotive electrical circuits are shown in the illustration.

Switch - A device that mechanically opens and closes an electrical circuit. Some switches are controlled by pressure, temperature or light.

Relay - An electromechanical device that utilizes a small amount of current to energize an electromagnet that closes the contacts in a circuit carrying a higher amount of current. The electromagnet in a relay has a fixed core that attracts a moveable armature.

Transistor - Semiconductor devices that function as switches with no moving parts. As the name implies, semiconductors conduct electricity part of the time and do not conduct at other times. These qualities let transistors function like electric relays.

Electronic Control Unit (ECU) - Often referred to as “the computer”, these units are nothing more than sophisticated switches. Like any other switching device, an ECU can be the control device in ground or power controlled circuits.

Other Types of Devices

Solenoid - An electromechanical device that utilizes a small amount of current to energize an electromagnet that closes the contacts in a circuit carrying a higher amount of current. The electromagnet in a solenoid has a moveable core that is pulled into the hollow coil.

Diode - Semiconductor devices that work like an electrical one way valve by allowing current to flow in only one direction. Commonly used when changing alternating current into direct current.

Capacitor - An electrical component that can store a small charge and then release it as needed. They can be used to store and release a high voltage, protect a circuit against surges or smooth out current fluctuations

- Relationship between voltage, amperage and resistance in an electrical circuit
- Current is directly proportional to voltage and inversely proportional to the resistance in a circuit
- Published by George Simon Ohm in 1826
- One volt of pressure will cause one ampere of current to flow in a circuit with a resistance of one ohm EC1-8

SOLVING CIRCLE

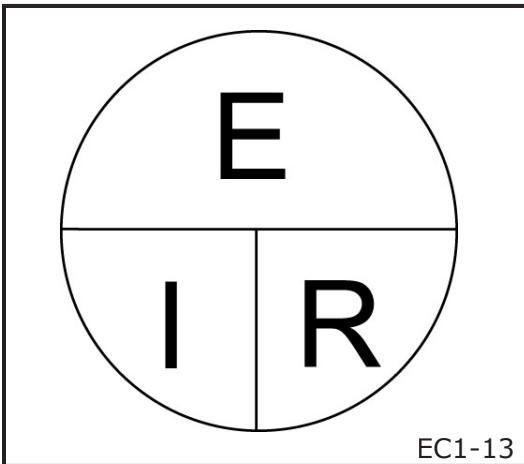

E = Voltage measured in Volts

I = Current measured in Amps

R = Resistance measured in Ohms

OHM'S LAW

In 1826 a German scientist named George Simon Ohm published his findings of the relationship between voltage, amperage and resistance in an electrical circuit. These findings were proved to be true and were named "Ohm's Law." **Ohm's Law states that the current that flows in a circuit is directly proportional to the voltage and inversely proportional to the resistance in the circuit.** One volt of pressure will cause one ampere of current to flow in a circuit with a resistance of one ohm.

Ohm's Law Relationship

If the resistance stays constant...current goes up as voltage goes up and current goes down as voltage goes down.

If voltage stays constant...current goes up as resistance goes down and current goes down as resistance goes up.

The relationship between voltage, current and resistance is such that any one value can be found when there are two known values. To make this easier to understand we can put Ohm's law in the form of the formula

$$E = I \times R.$$

In this formula, E represents voltage, I represents current and R represents resistance. To find current, we use the formula

$$I = E/R$$

and to find resistance we use the formula

$$R = E/I.$$

Using the divided circle method makes it easier to remember the formulas.

SOLVING TABLE

<p>$\frac{12}{4} = 3A$</p> <p>I = Amps</p>	<p>$3 \times 4 = 12v$</p> <p>E = Volts</p>	<p>$\frac{12}{3} = 4 Ohms$</p> <p>R = Ohms</p>
---	---	---

SOLVING CIRCLE

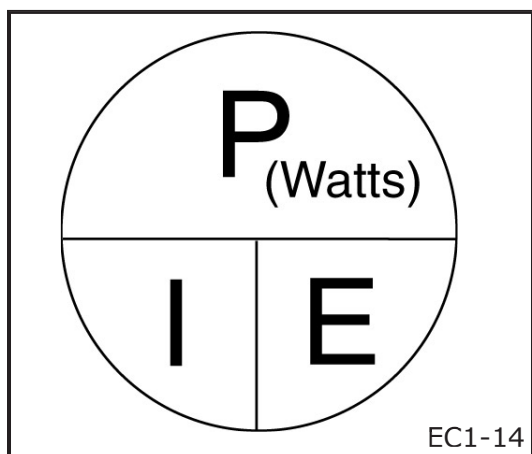

The same relationship may be found between power, current and voltage. To find the power or wattage used in a circuit we can use the formula $P = I \times E$. We can also find current by using the formula $I = P/E$ or find voltage using the formula $E = P/I$. To remember the formulas use the divided circle method.

P = Power measured in Watts

I = Current measured in Amps

E = Voltage measured in Volts

ACTIVITY

VERIFYING OHM'S LAW

In this activity you will be able to observe the relationship between current and voltage and between current and resistance. Make the circuit shown in the picture below connecting R-1 with lead wires. Turn the potentiometer knob to set the voltage at 4.0v. Measure and record the current of the circuit. Then do the same measurement with R-2 and R-3.

Next, adjust the voltage up to 8V with the potentiometer and measure the current when R-1, R-2 and R-3 are alternately placed in the circuit.

Finally, measure the current with the voltage set at 12 volts and alternately R-1, R-2 and R-3 in the circuit.

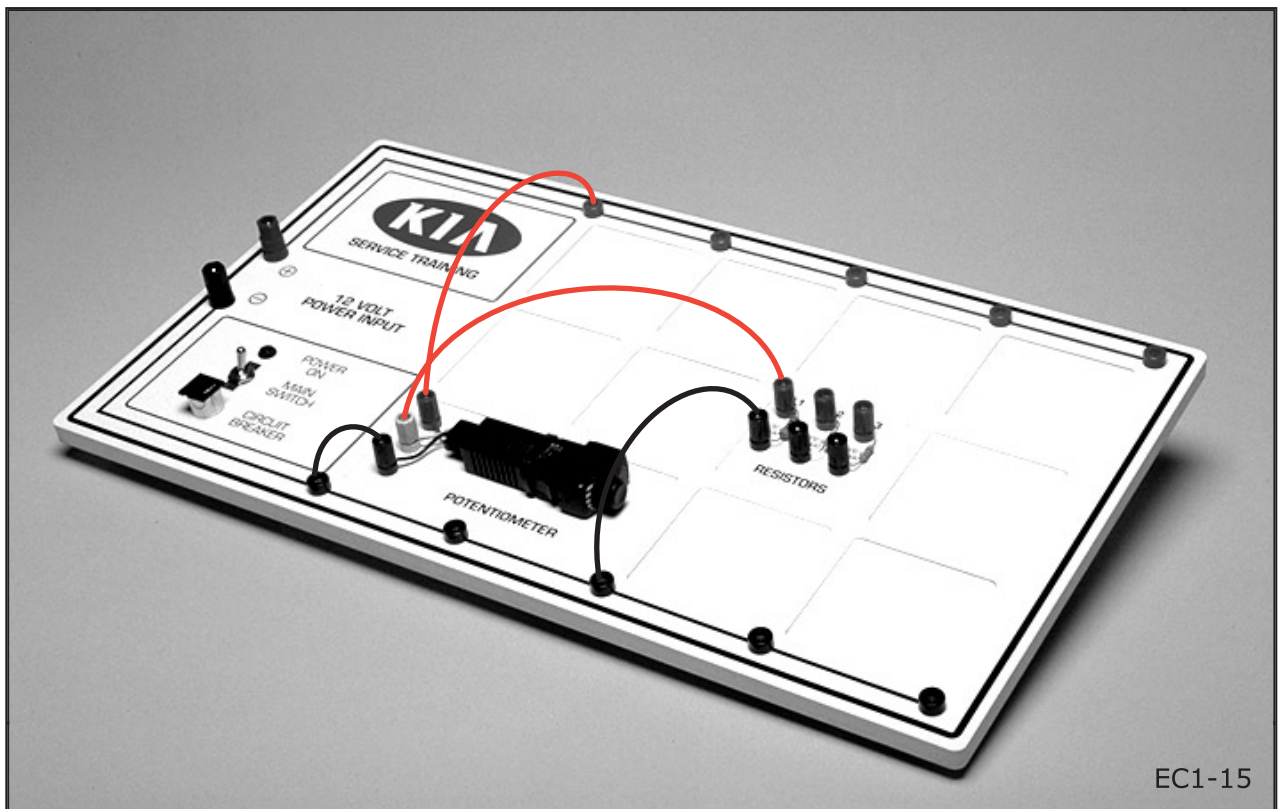

EC1-15



ACTIVITY

	4V	8V	12V
R-1 (100 ohm)	A	A	A
R-2 (200 ohm)	A	A	A
R-3 (300 ohm)	A	A	A

In the space below explain what you have found about the relationship between voltage, current and resistance.

- Series
One path for current flow
- Parallel
More than one path for current flow
- Series - Parallel
Combination of series and parallel circuits
- Circuit behavior is determined by the type of circuit

EC1-16

TYPES OF CIRCUITS

Electrical circuits must form a complete loop, but they can be connected in different ways. There are three basic types of circuits, each with its own characteristics. How the components are connected within the circuit determines the type of circuit.

Each type of circuit causes voltage and current to divide according to specific rules.

Series Circuit

A series circuit has only one path for the current to flow. All the components are connected in-line. The same amount of current will flow through each component but the voltage will drop as current flows through each load device. If an open occurs anywhere in the path there will be no current flow.

An example of a series circuit would be the old type of christmas tree lights. When one bulb burns out or is removed, the rest of the lights go out also. A common example of an automotive series circuit is the cigarette lighter.

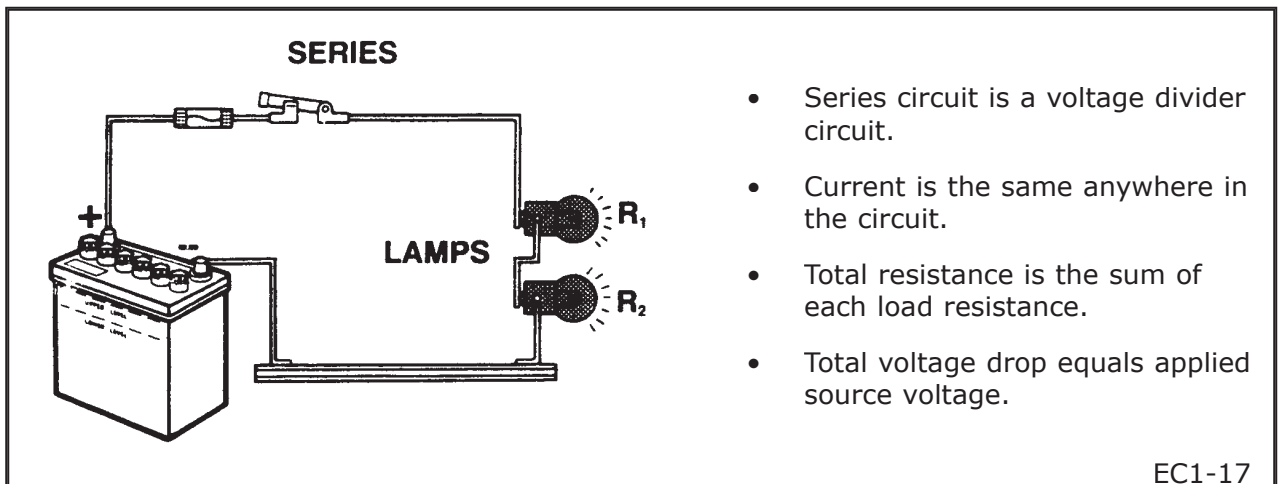

EC1-17

SERIES CIRCUIT EXAMPLE

In this series circuit example, when the ignition switch is in the ACC or ON position current coming from the battery flows from the ignition switch through the cigar lighter 15A fuse through connectors C230 and C248 to the cigarette lighter heater element.

When the cigarette lighter is pressed in, the circuit is completed from terminal #1 of connector C248 to terminal #2 of connector C248. Current can then flow from terminal #2 of connector C248 to ground, completing the circuit back to the battery.

In this type of circuit, any break (intentional or unintentional) in the circuit will cause current flow to stop.

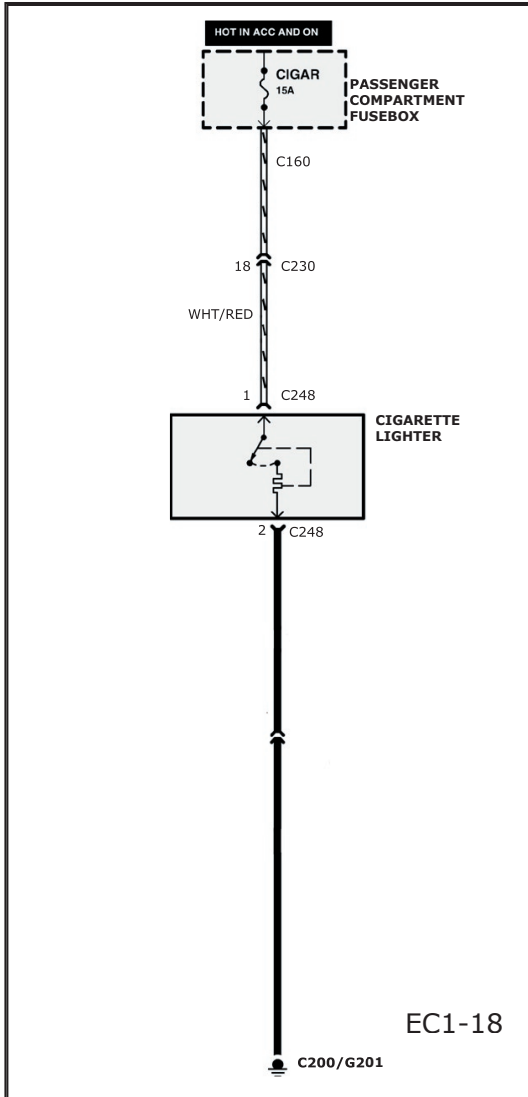

ACTIVITY

Measuring Voltage in a Series Circuit

In this activity, we are measuring the available source voltage and the voltage drop of a normally operating circuit with the loads arranged in series.

Complete the table on the following page using information obtained by taking voltage measurements at the points illustrated in the diagram.

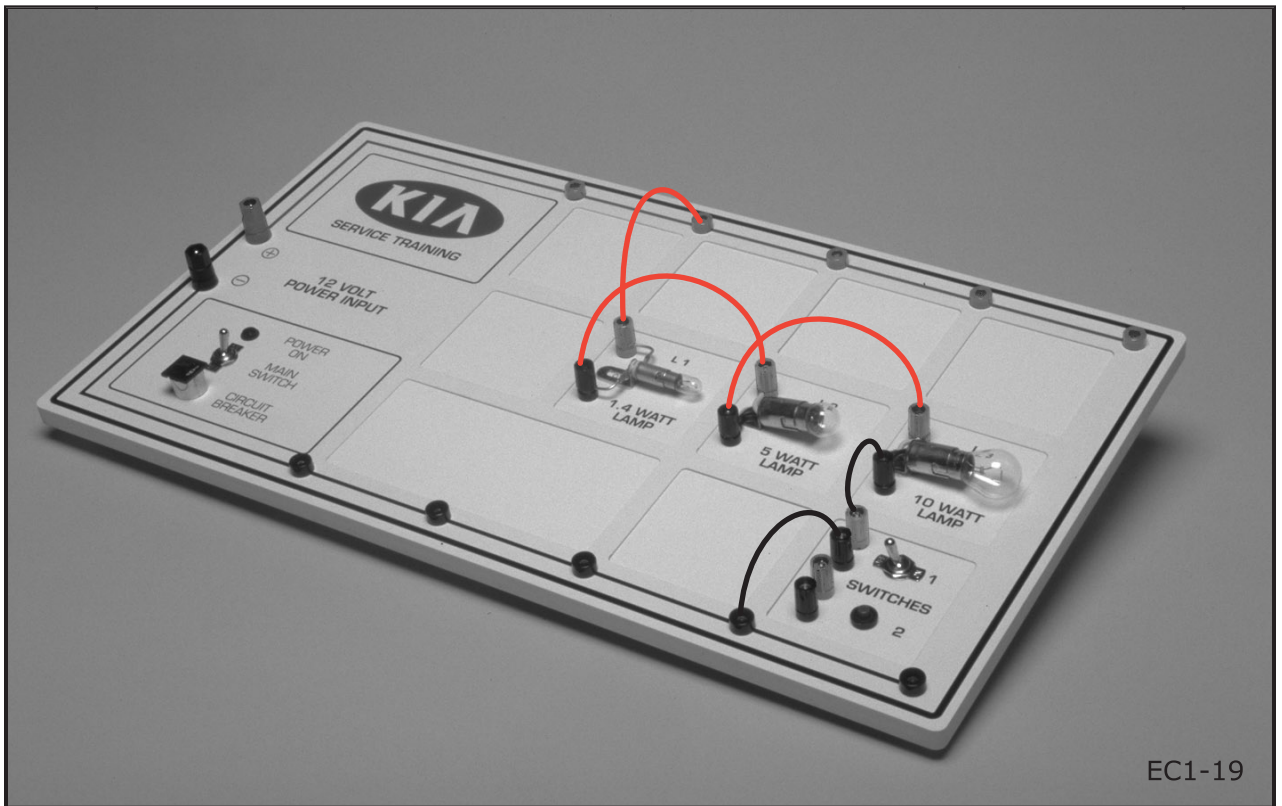

ACTIVITY

VOLTAGE : LOADS CONNECTED IN SERIES

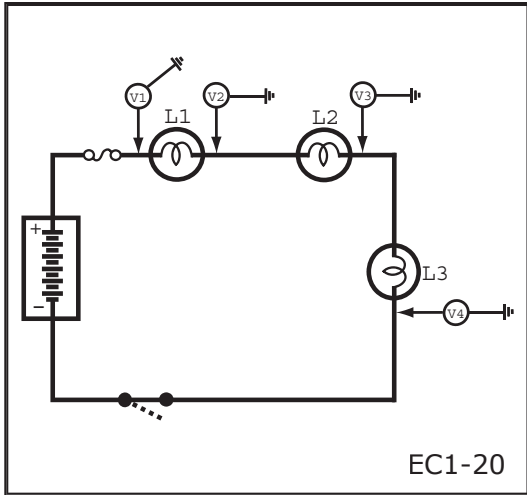

EC1-20

V_1	Source Voltage	V
V_2	Lamp 1	V
V_3	Lamp 2	V
V_4	Lamp 3	V

In the space below explain what the voltage measurements you obtained tell us about voltage in a series circuit.

ACTIVITY

Measuring Current in a Series Circuit

In this activity, we are measuring the current at different locations within a normally operating circuit with the loads arranged in series.

CAUTION

Always start measuring with the ammeter on the highest scale and work your way down to prevent damage to the meter.

EC1-21

Complete the table and questions on the following page using information obtained by taking current measurements at the points illustrated in the diagram.

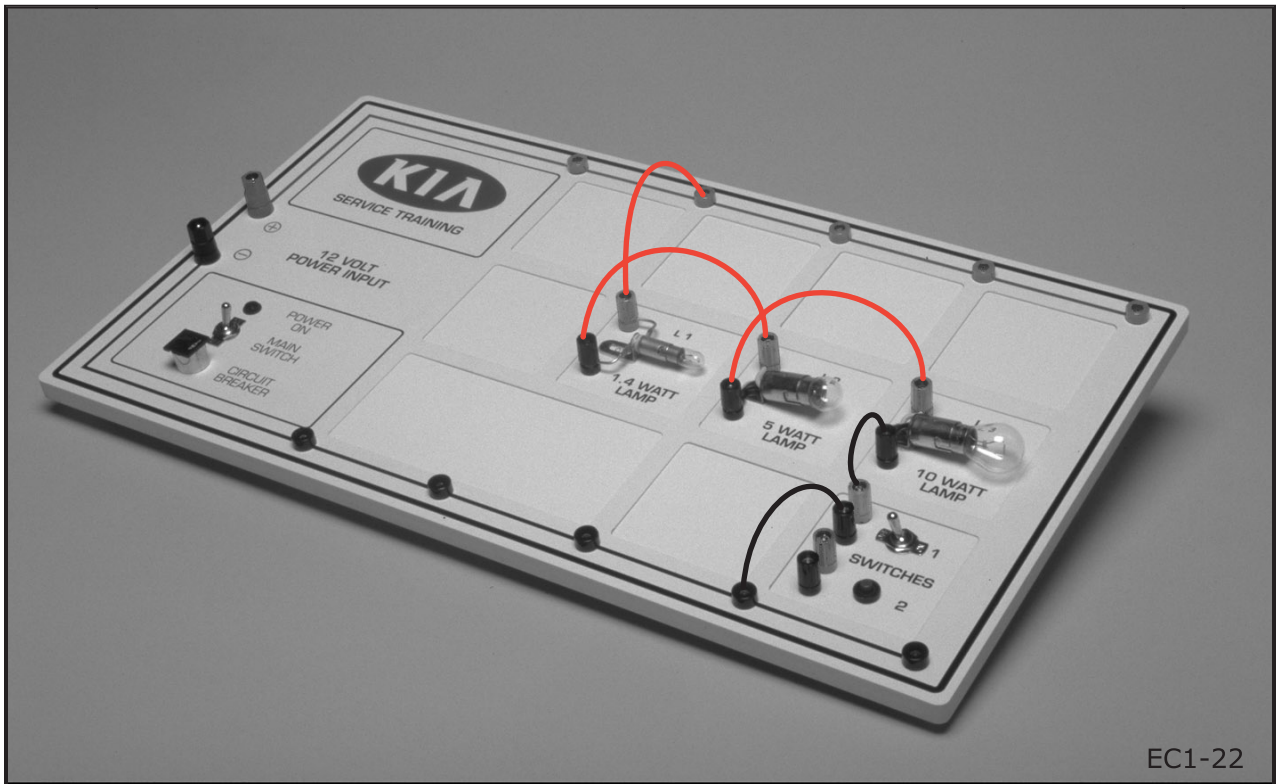

ACTIVITY

CURRENT: LOADS CONNECTED IN SERIES

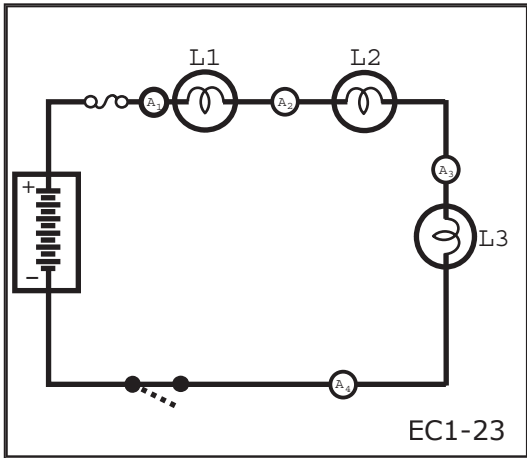

A_1	Source Current	A
A_2	Lamp 1	A
A_3	Lamp 2	A
A_4	Lamp 3	A

In the space below explain what the current measurements you obtained tell us about current in a series circuit.



ACTIVITY

Measuring Resistance in a Series Circuit

In this activity, we are measuring the resistance at different locations within a series circuit with more than one load device and the total resistance of the entire circuit.

Complete the table and questions on the following page using information obtained by taking resistance measurements at the points illustrated in the diagram.

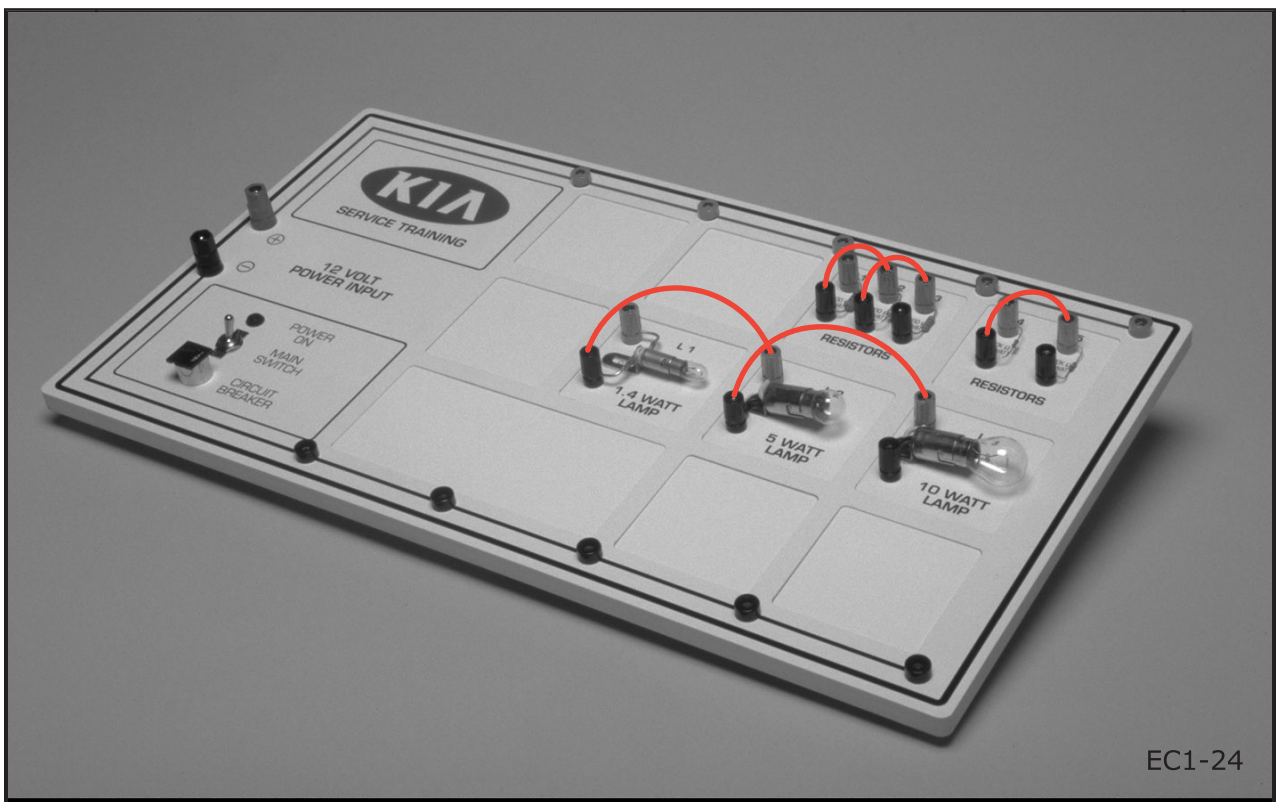

ACTIVITY

RESISTANCE: LOADS CONNECTED IN SERIES

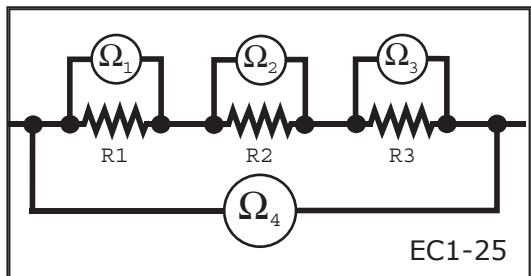

Ω_1	Resistor 1	Ω
Ω_2	Resistor 2	Ω
Ω_3	Resistor 3	Ω
Ω_4	Total Resistance	Ω

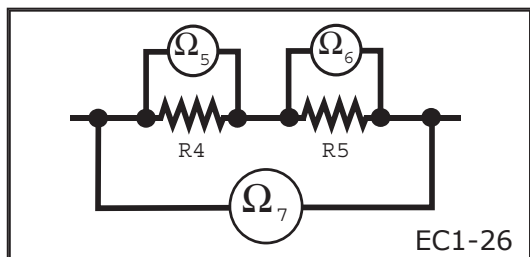

Ω_5	Resistor 4	Ω
Ω_6	Resistor 5	Ω
Ω_7	Total Resistance	Ω

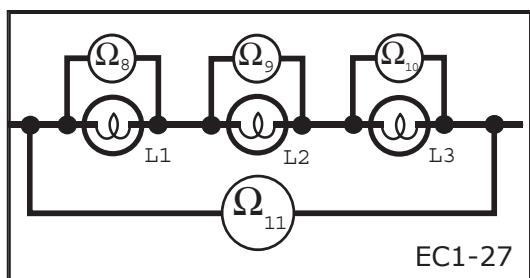

Ω_8	Lamp 1	Ω
Ω_9	Lamp 2	Ω
Ω_{10}	Lamp 3	Ω
Ω_{11}	Total Resistance	Ω

In the space below explain what the resistance measurements you obtained tell us about resistance in a series circuit.

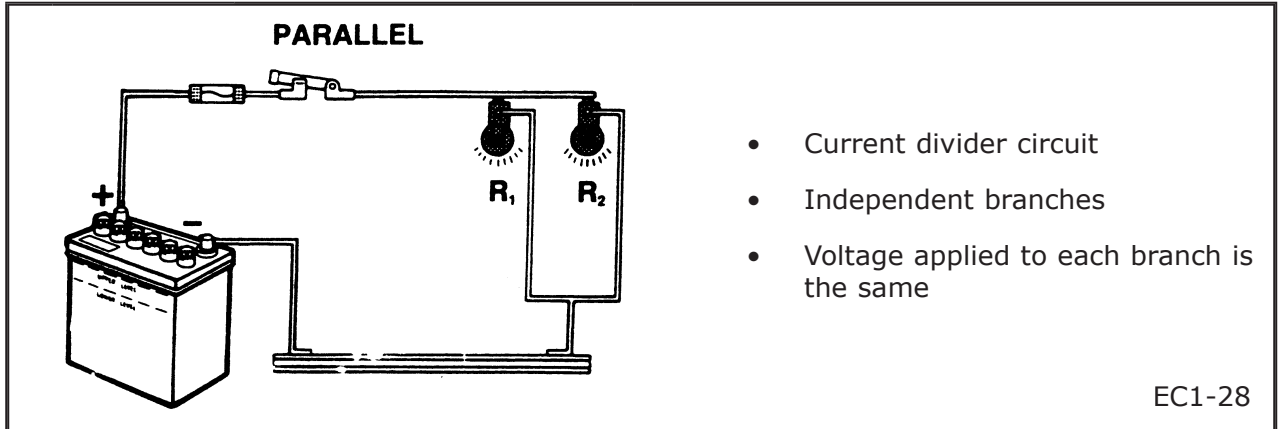

PARALLEL CIRCUITS

A parallel circuit has more than one path for the current to flow. Each branch receives the same voltage. If the load in each branch has the same resistance then the current will be the same in each branch. If the load in each branch has a different resistance then the current will be different for each branch.

If an open occurs in one or more of the branches, the remaining branches will continue to have current flow.

A back-up light circuit is one example of a parallel circuit.

Parallel Circuit Rules

Electrical behavior in all parallel circuits is governed by the rules shown in the illustration.

These rules apply to all parallel circuits regardless of the type and number of load devices.

- Voltage applied to each load equals the source voltage
- Load resistance determines the current through each load
- Total circuit resistance is less than the lowest load resistance
- Total current equals the sum of the branch currents

EC1-29

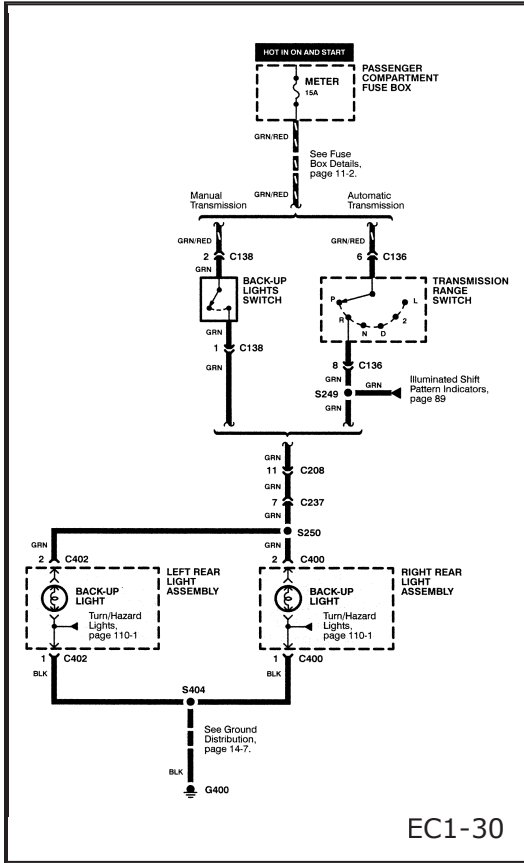

Parallel Circuit Example

In this parallel circuit example, current flows from the battery through the ignition switch (ON or START position) and the 15 amp meter fuse to either the back-up light switch (M/T) or the transmission range switch (A/T).

When the transmission shift lever is moved to the reverse position, current flows through either the back-up light switch (M/T) or the transmission range switch (A/T) to splice S250.

Current splits at the splice and travels to each of the two back-up lights.

On the ground side of the circuit, current flows from the back-up lights through splice S404 to grounding point G400 and back to the battery through the vehicle body.

If either bulb burns out or either parallel branch develops an open, the unaffected bulb will continue to operate.

ACTIVITY

Measuring Voltage in a Parallel Circuit

In this activity, we are measuring the available source voltage and the voltage drop of a normally operating circuit with the loads arranged in parallel.

Use the picture below to help you build the parallel circuit using lamps L1, L2 & L3. Then complete the table on the following page using information obtained by taking voltage measurements at the points illustrated in the diagram.

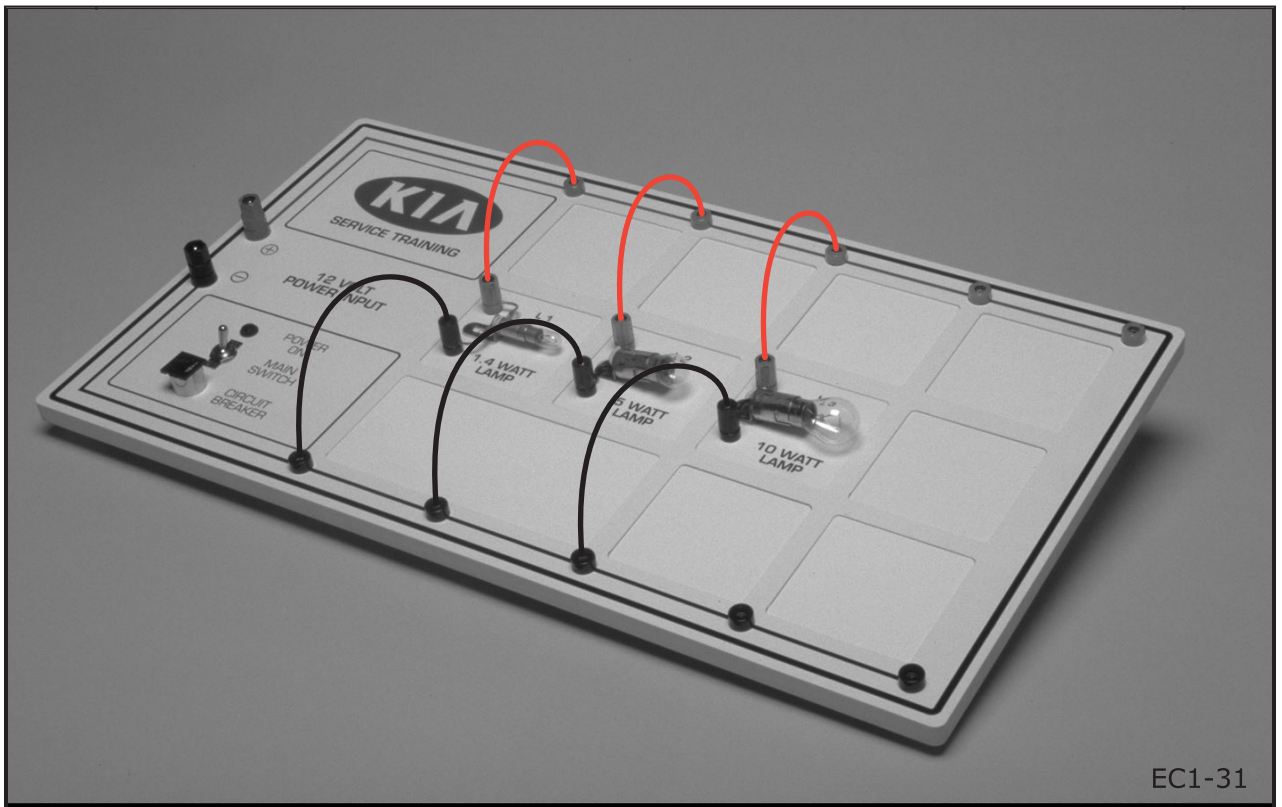

ACTIVITY

VOLTAGE: LOADS CONNECTED IN PARALLEL

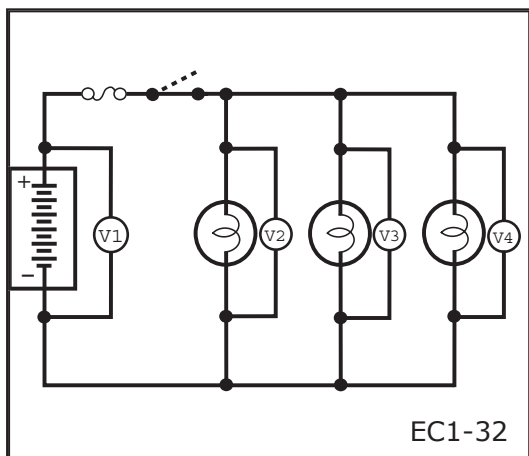

V_1	Source Voltage	V
V_2	Lamp 1	V
V_3	Lamp 2	V
V_4	Lamp 3	V

In the space below explain what the voltage measurements you obtained tell us about voltage in a parallel circuit.

ACTIVITY

Measuring Current in a Parallel Circuit

In this activity, we are measuring the current at different locations within a normally operating circuit with the loads arranged in parallel.

CAUTION

Always start measuring with the ammeter on the highest scale and work your way down to prevent damage to the meter.

EC1-33

Use the picture below to help you build the parallel circuit. Then complete the table and questions on the following page using information obtained by taking current measurements at the points illustrated in the diagram.

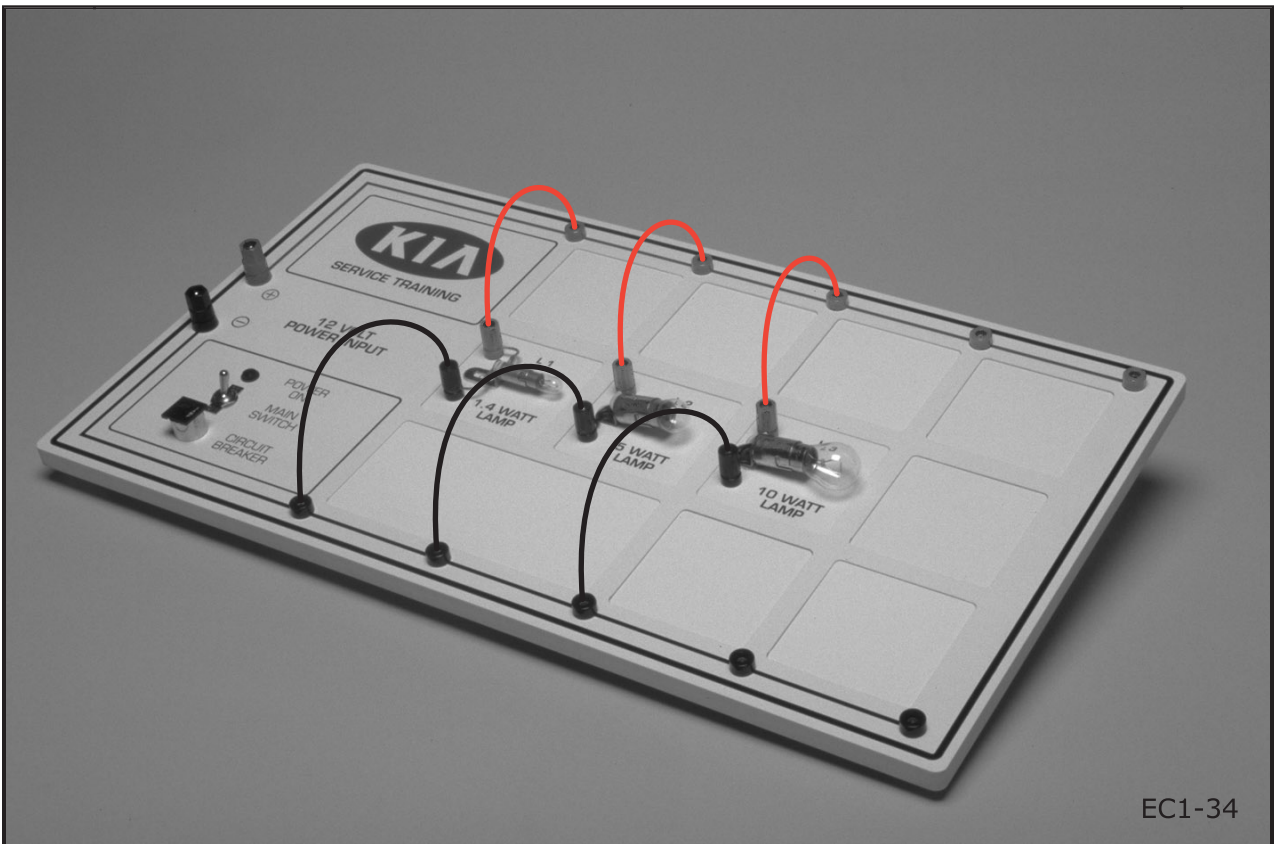

ACTIVITY

CURRENT: LOADS CONNECTED IN PARALLEL

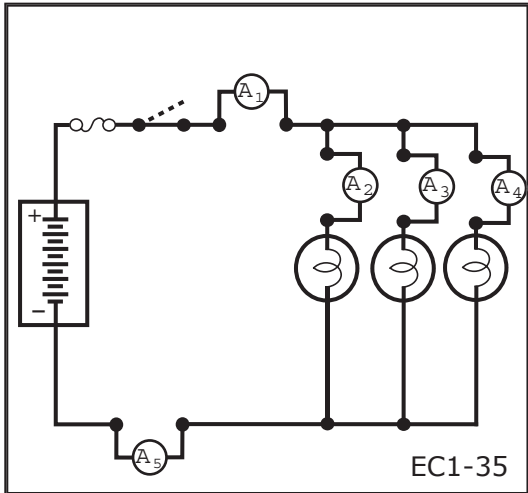

A ₁	Source Current	A
A ₂	Lamp 1	A
A ₃	Lamp 2	A
A ₄	Lamp 3	A
A ₅	Total	A

In the space below explain what the current measurements you obtained tell us about current in a parallel circuit.

ACTIVITY

Measuring Resistance in a Parallel Circuit

In this activity, we are measuring the resistance at different locations within a parallel circuit and the total resistance of the entire circuit.

Measure the resistances of R1, R2 & R3. Connect R1, R2 & R3 in parallel as shown in the illustration / picture below and measure the combined resistance. Then complete the table and questions on the following page using information obtained by taking resistance measurements at the points illustrated in the diagram.

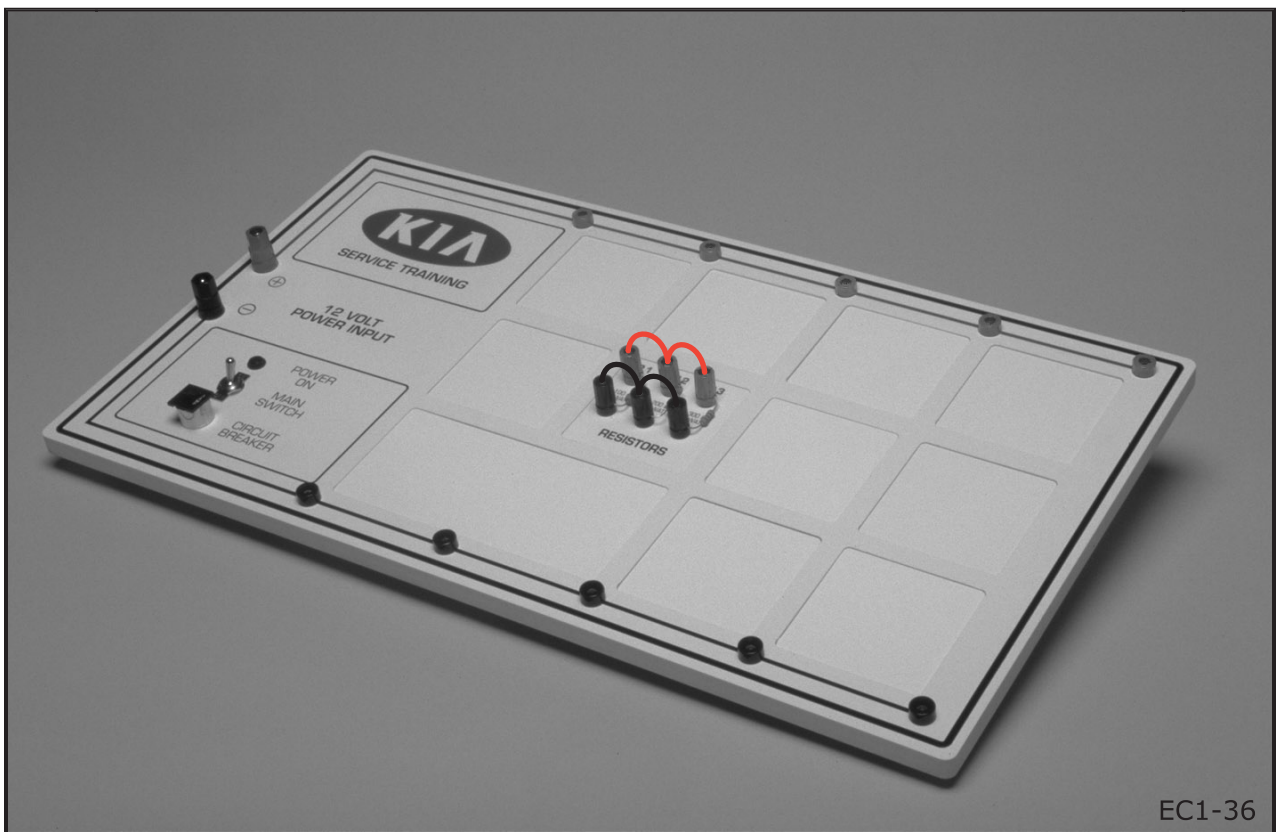

EC1-36

ACTIVITY

RESISTANCE: LOADS CONNECTED IN PARALLEL

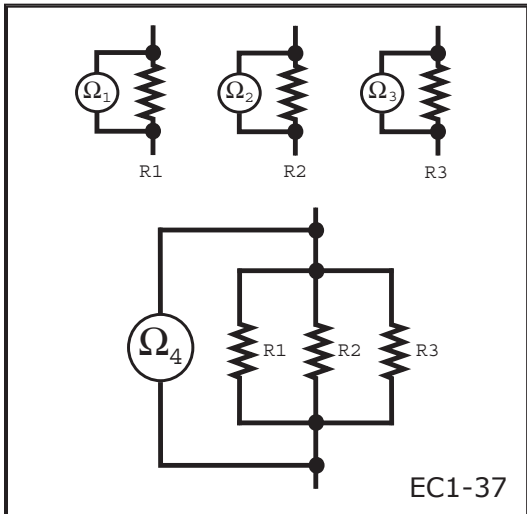

Ω_1	Resistor 1	Ω
Ω_2	Resistor 2	Ω
Ω_3	Resistor 3	Ω
Ω_4	Total Resistance	Ω

In the space below explain what the resistance measurements you obtained tell us about resistance in a parallel circuit.



This page left intentionally blank.

SERIES-PARALLEL

RHEOSTAT

- Combines characteristics of series and parallel circuits
- Some components are in series and others are in parallel
- Power source, control and protection devices are normally in series
- Loads are normally in parallel

EC1-38

- Current in the series section equals sum of parallel branch circuits
- Total circuit resistance equals parallel resistance plus series resistance
- Voltage applied to the parallel portion equals applied source voltage minus voltage drop across series portion

EC1-39

SERIES-PARALLEL CIRCUITS

Normally in a series-parallel circuit, the power source, control and protection devices are in series and the loads are in parallel.

If an open occurs in the series portion, the whole circuit will lose current flow.

If an open occurs in a parallel branch, the current flow will remain in the series portion and the remaining parallel branches.

The instrument panel lighting circuit is one example of a series-parallel circuit.

Series Parallel Circuit Rules

Electrical behavior in all series-parallel circuits is governed by the rules shown in the illustration.

These rules apply to all series-parallel circuits regardless of the type and number of load devices.



Series-Parallel Circuit Example

In the series-parallel circuit shown on the previous page, current flows from the battery through the light switch (Park or Head position), and the 10 amp tail fuse to the instrument panel dimmer switch. This is the series portion of the circuit.

On the output side of the dimmer switch, current flows to splice S251 where it divides and travels to all of the instrument panel lights.

All instrument panel lights are connected on the ground side to splice S219. From splice S219 the current flow path is through grounding points G200 and G201 back to the battery through the vehicle body.

The circuitry between splice S251 and S219 is considered to be the parallel portion of the circuit.

When diagnosing a series-parallel circuit, remember:

- If an open occurs in the series portion the whole circuit will lose current flow.
- If an open occurs in a parallel branch the current flow will remain in the series portion and the remaining parallel branches.



INSTRUMENT PANEL LIGHTING

(Partial View)

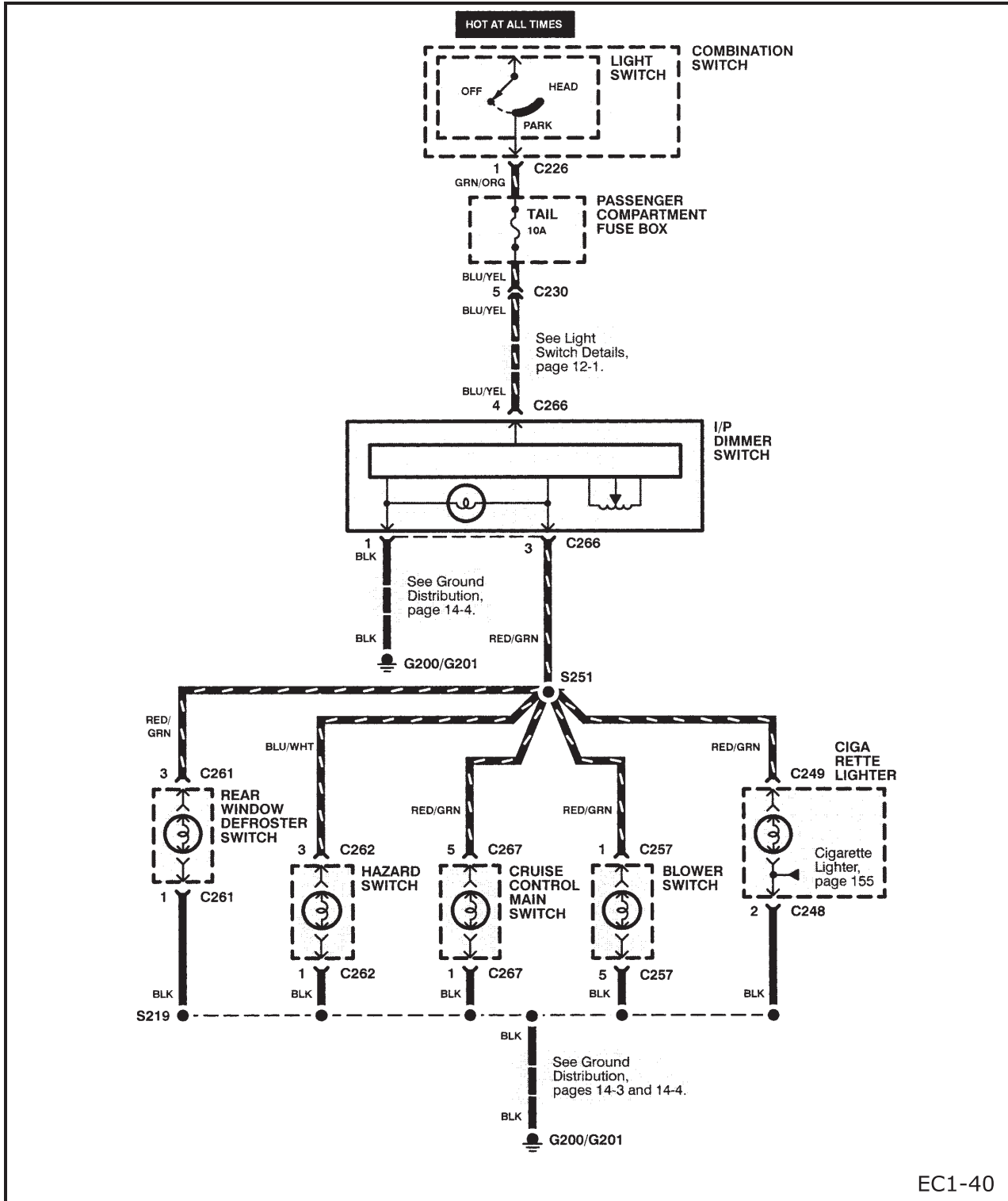

EC1-40

ACTIVITY

Measuring Voltage in a Series-Parallel Circuit

In this activity, we are measuring the available source voltage and the voltage drop of a normally operating circuit with the loads arranged in series-parallel.

Use the picture below to help you build the series-parallel circuit. Then complete the table on the following page using information obtained by taking voltage measurements at the points illustrated in the diagram.

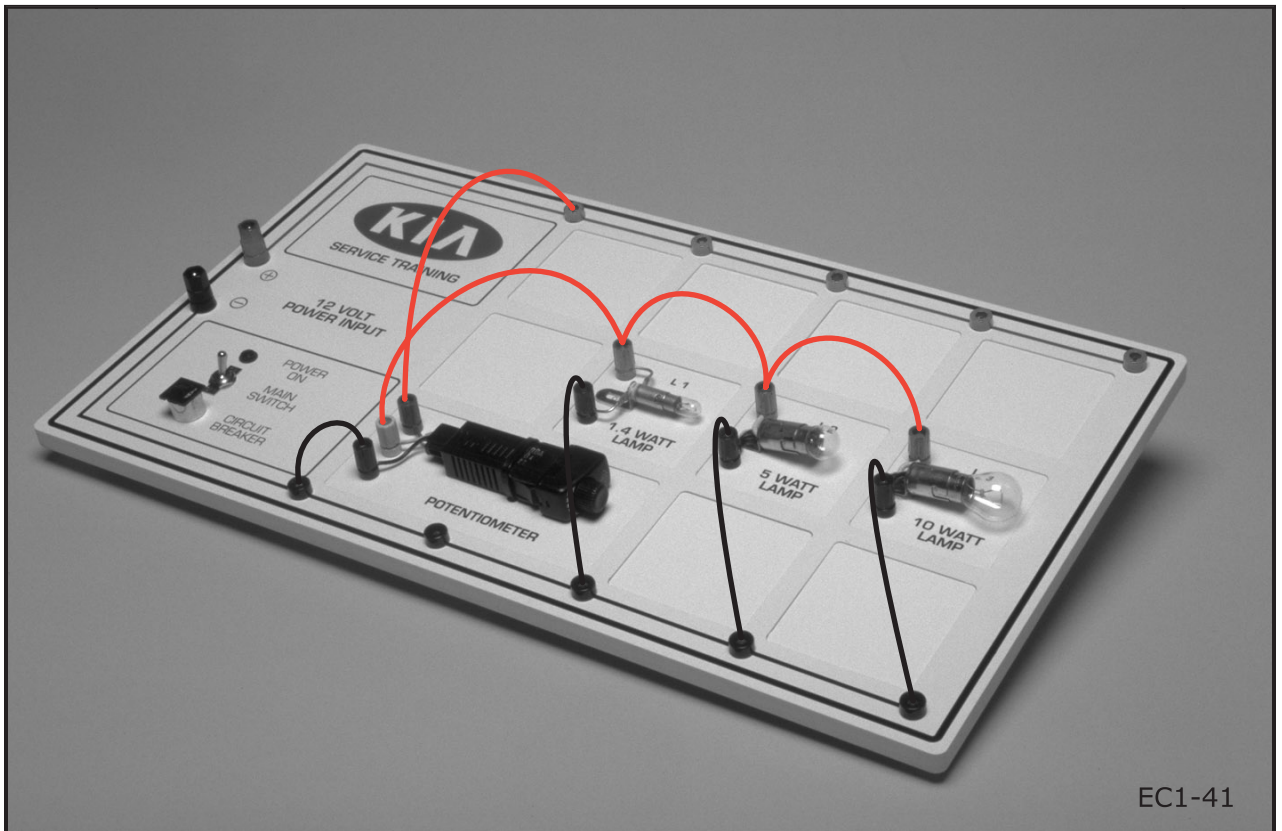

EC1-41

ACTIVITY

VOLTAGE: LOADS CONNECTED IN SERIES-PARALLEL

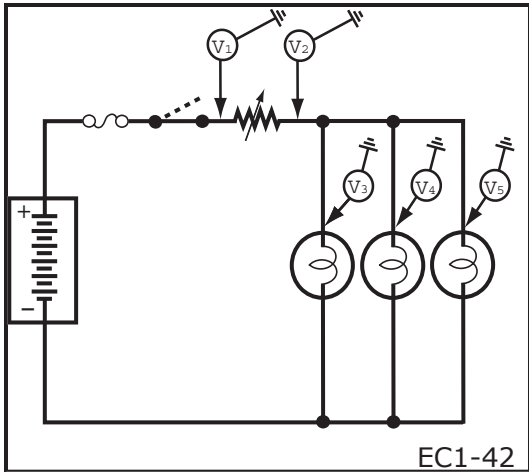

V_1	Source Voltage	V
V_2	Potentiometer	V
V_3	Lamp 1	V
V_4	Lamp 2	V
V_5	Lamp 3	V

In the space below explain what the voltage measurements you obtained tell us about voltage in a series-parallel circuit.

ACTIVITY

Measuring Current in a Series-Parallel Circuit

CAUTION

Always start measuring with the ammeter on the highest scale and work your way down to prevent damage to the meter.

EC1-43

In this activity, we are measuring the current at different locations within a normally operating circuit with the loads arranged in series-parallel.

Use the picture below to help you build the series-parallel circuit. Then complete the table and questions on the following page using information obtained by taking current measurements at the points illustrated in the diagram. Remove a load from the parallel portion and note what happens to the total current.

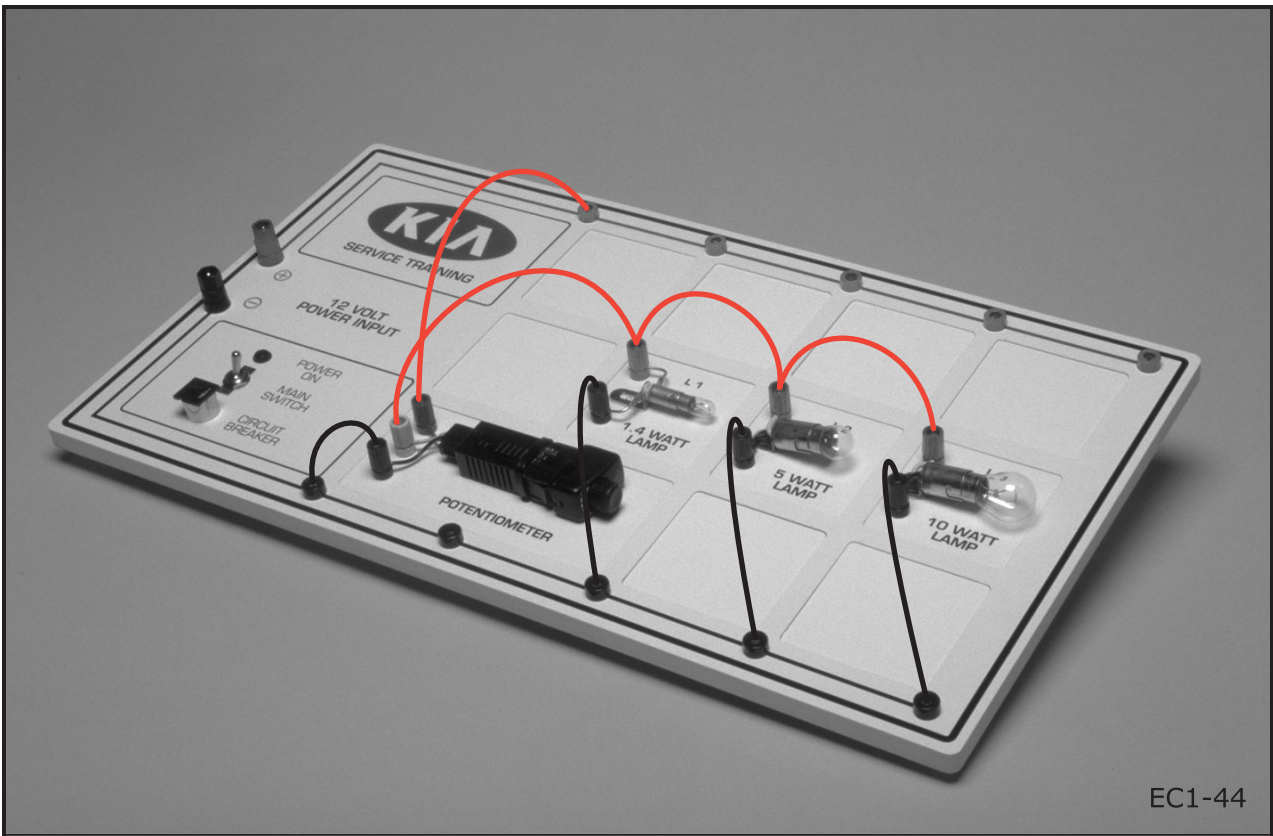

EC1-44

ACTIVITY

CURRENT: LOADS CONNECTED IN SERIES-PARALLEL

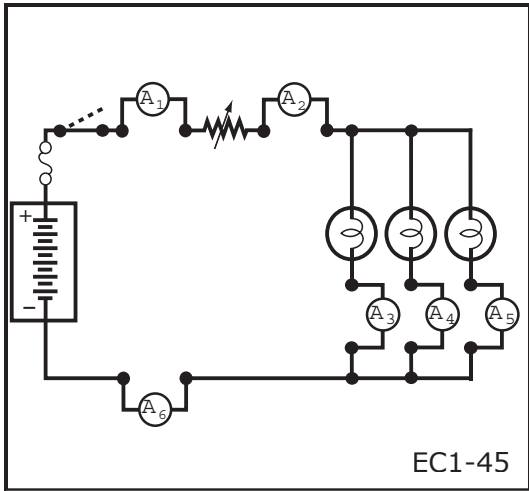

A ₁	Source Current	A
A ₂	Potentiometer	A
A ₃	Lamp 1	A
A ₄	Lamp 2	A
A ₅	Lamp 3	A
A	Total Current	A

In the space below explain what the current measurements you obtained tell us about current in a series-parallel circuit.

ACTIVITY

Measuring Resistance in a Series-Parallel Circuit

In this activity, we are measuring the resistance at different locations within a series-parallel circuit and the total resistance of the entire circuit.

Use the picture below to help you build the series-parallel circuit. Then complete the table and questions on the following page using information obtained by taking resistance measurements at the points illustrated in the diagram.

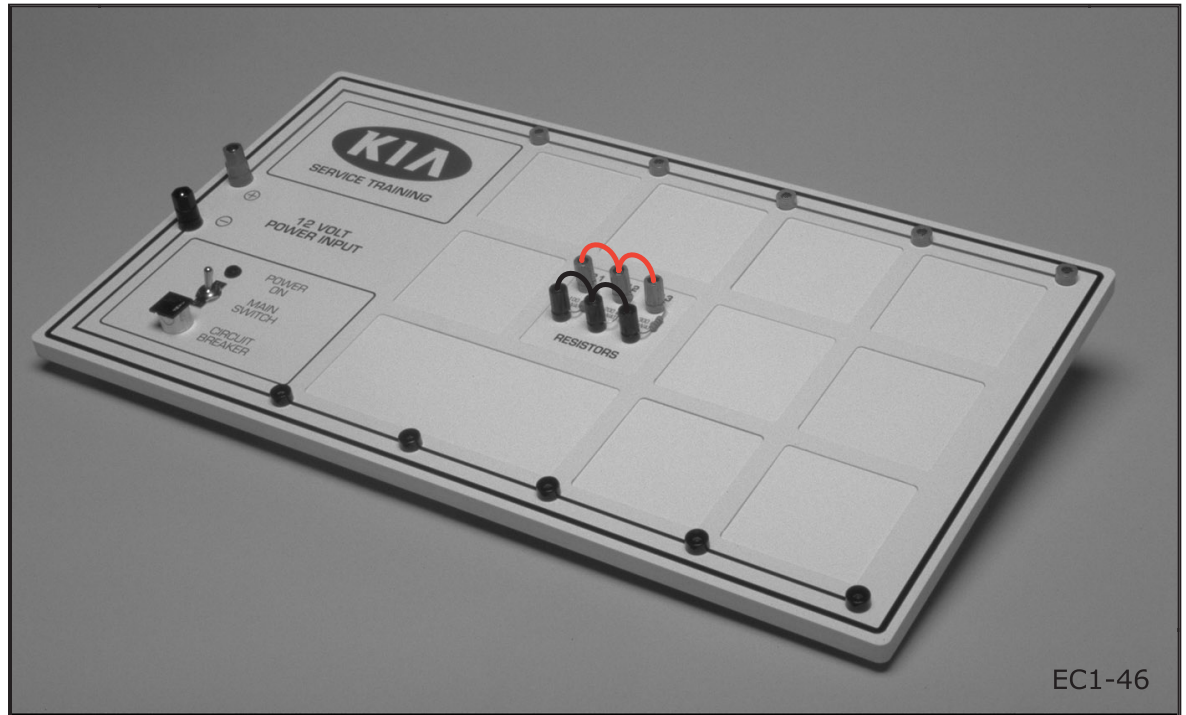



ACTIVITY

RESISTANCE: LOADS CONNECTED IN SERIES-PARALLEL

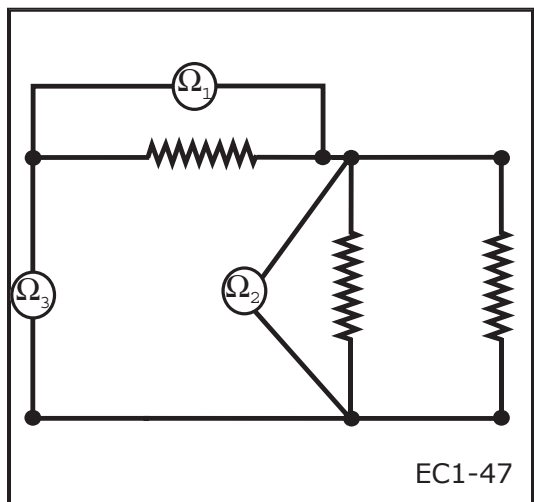

Ω_1	Series	Ω
Ω_2	Parallel	Ω
Ω_4	Total Resistance	Ω

In the space below explain what the resistance measurements you obtained tell us about resistance in a series-parallel circuit.

- Power controlled
- Ground controlled
- Reversible
- Combination of two or more types of control

EC1-48

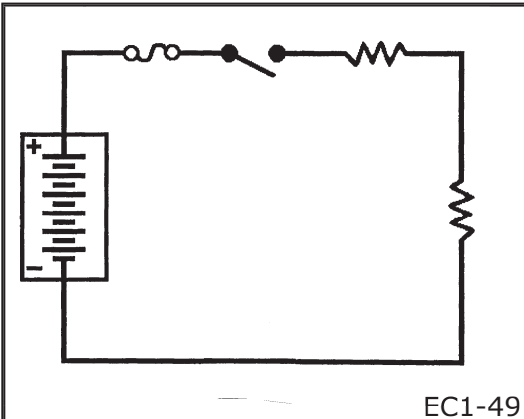

EC1-49

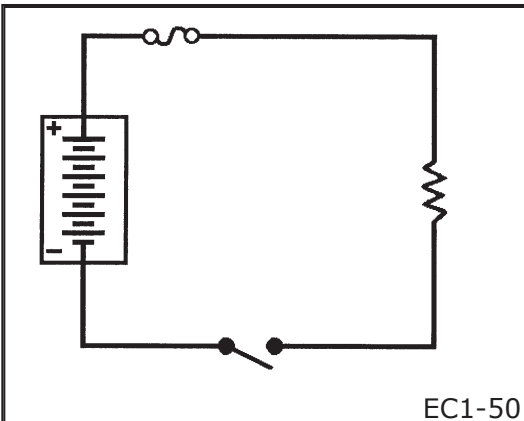

EC1-50

CIRCUIT CONTROL METHODS

Automotive electrical circuits can be power controlled, ground controlled or reverse polarity. Some circuits use a combination of control methods.

Power Controlled Circuits

In a power controlled circuit, the control device is located between the voltage source and the load.

Current to the load is controlled by completing or interrupting the path between the voltage source and the load.

The load is always connected to ground in this type of circuit.

Ground Controlled Circuits

In a ground controlled circuit, the control device is located between the load and ground.

The load is controlled by completing or interrupting the path to ground.

The power side of the circuit is always powered and voltage is always available at the positive side of the load device.

- Normally two series circuits that share a common ground and power supply
- For actuators or motors operating in 2 directions (e.g. power door lock)
- Direction of operation achieved by changing polarity of applied voltage

EC1-51

REVERSIBLE POLARITY CIRCUITS

Reversible polarity circuits are normally two separate series circuits that share a common ground and a common power supply. They are used when actuators must be able to run in two directions, like power door lock, power mirror and power window motors.

These circuits are wired so that either side of the motor or actuator can be connected to the voltage source. It operates in one direction when one lead is positive and in the other direction when the other lead is positive.

Reversible Polarity Circuit Example

Most reversible polarity circuits include two relays that share a common ground. One motor lead connects to the first relay and the other motor lead connects to the second relay. Each side of the motor is grounded when its relay is de-energized.

When one relay is energized, it switches one motor lead connection from ground to the positive side of the voltage source. The other motor lead remains grounded.

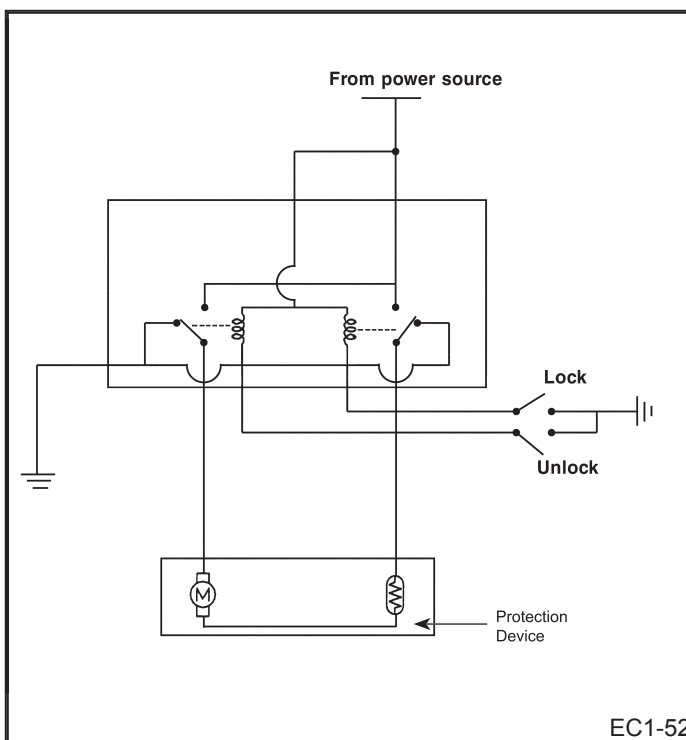

Current flows from the voltage source through the closed contacts of the energized relay, through the motor and finally to ground through the de-energized relay.

Reverse polarity circuits normally have a protection device which can be a circuit breaker or a positive temperature coefficient (PTC) resistor. These devices protect the circuit in the event that the device being moved by the motor reaches its stop and power is being applied.

ACTIVITY

Build a Reversible Polarity Circuit

In this activity, we will build a reversible polarity circuit so that the switching action can be seen. Connect the blade switch and motor with lead wires. Use the picture below to help you build the reversible polarity circuit. Describe what is taking place when the switch is placed in each position.

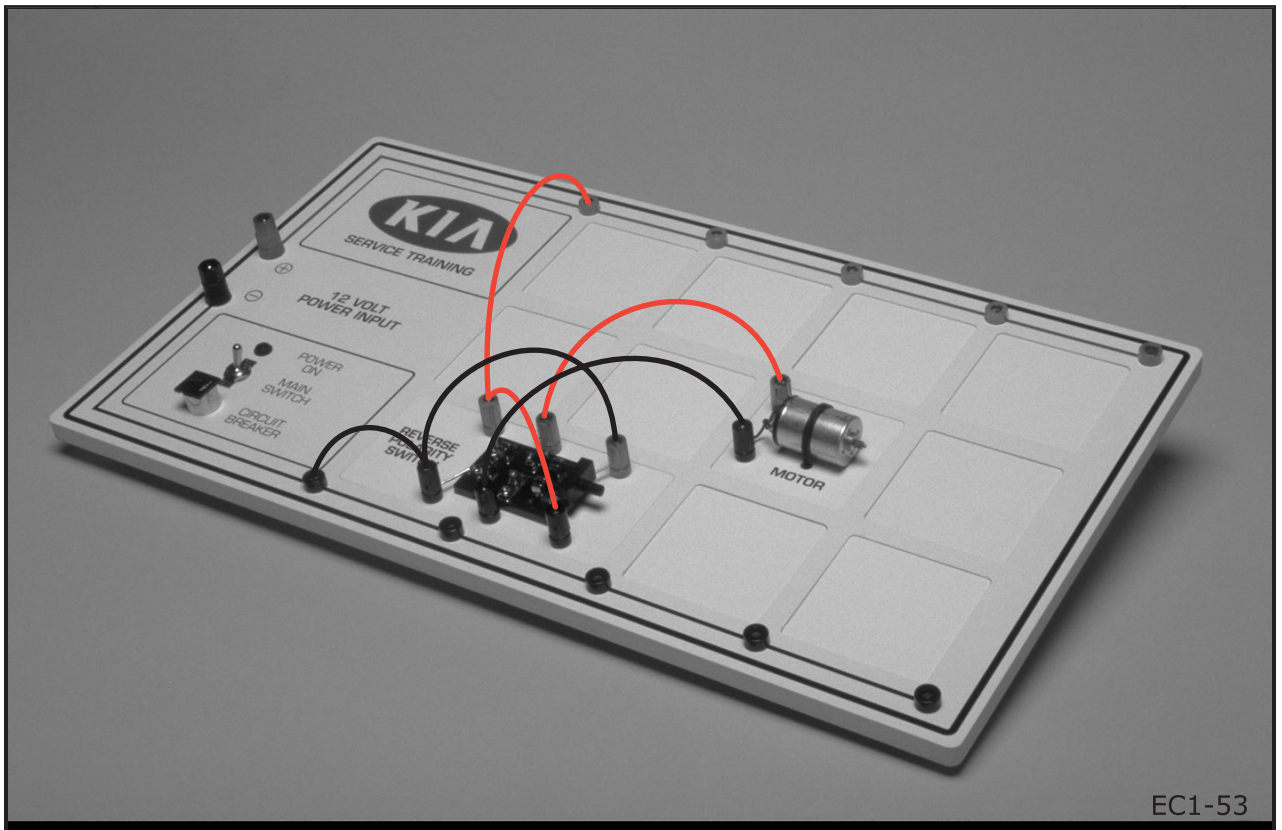

EC1-53

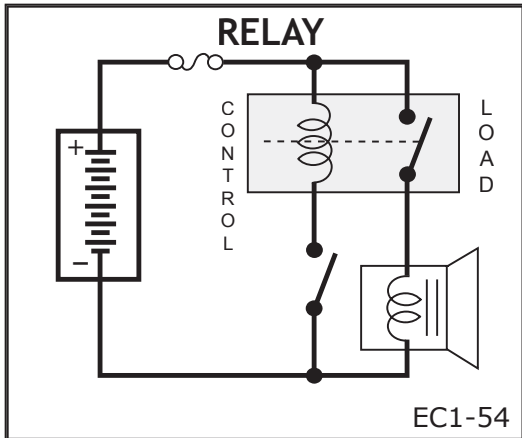

ACTIVITY

Functions of Relays

A relay is simply just a remote control switch. A small amount of current is allowed to flow through an electromagnetic coil. The electromagnetic effect pulls an armature towards the coil causing a set of contacts to close. Once the contacts are closed a higher amount of current is allowed to flow through the contact points.

Build the circuit shown in the picture below using the relay, switch and buzzer and describe its operation.

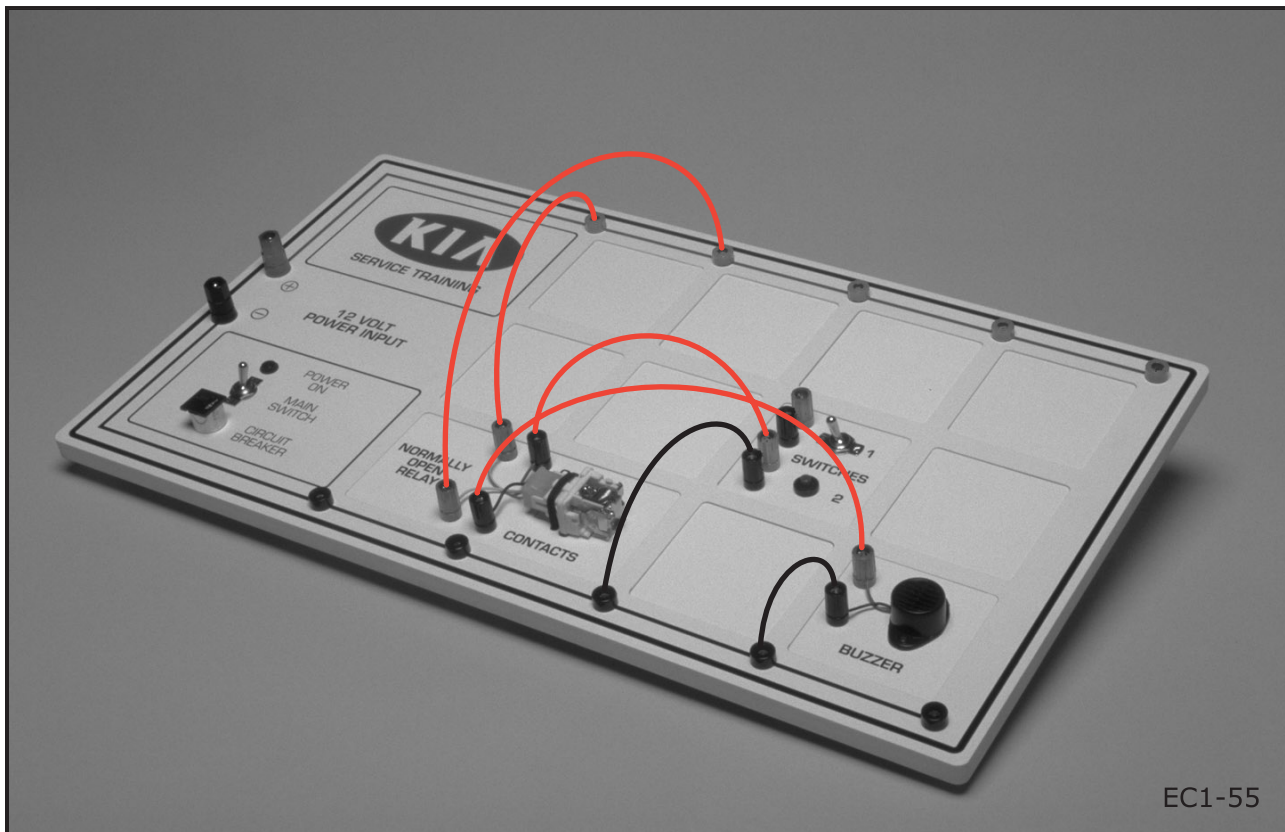

Functions of Capacitors

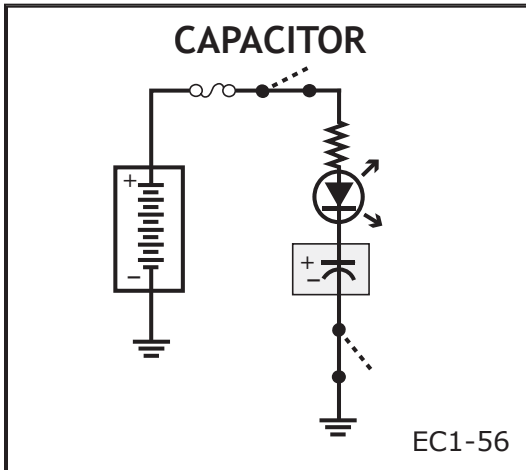

Build the circuit shown in the picture below. Allow the capacitor to charge then remove the power source. Describe what happens.

A capacitor is a device for storing an electrical charge. A capacitor consists of two plates made of an electrically conducting material separated by a nonconducting material or dielectric. If voltage is applied to the capacitor plates, the plates will become charged, one positively and one negatively. If the externally applied voltage is then removed, the capacitor plates remain charged, and the electric charge induces an electric potential between the two plates. The capacitor's ability to store a charge can be increased by increasing the area of the plates, by decreasing their separation or by varying the substance used as an insulator. When the charged capacitor is shorted, discharge current will flow from the capacitor.

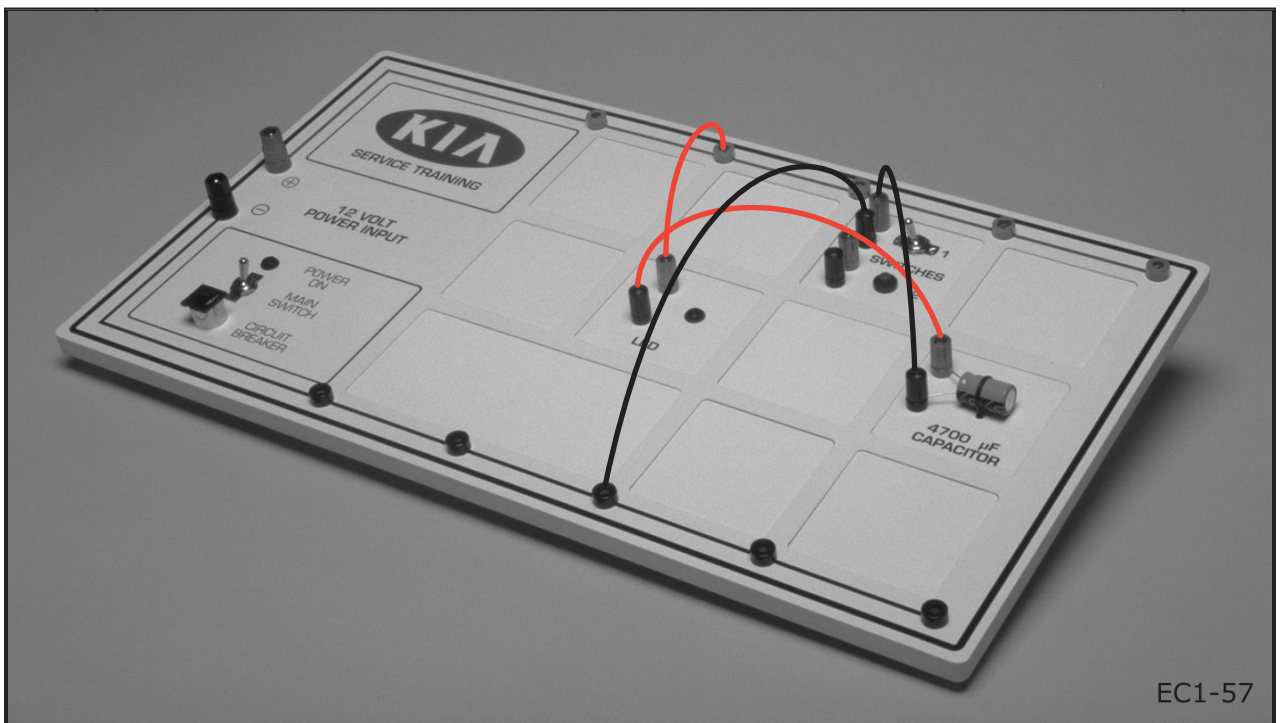

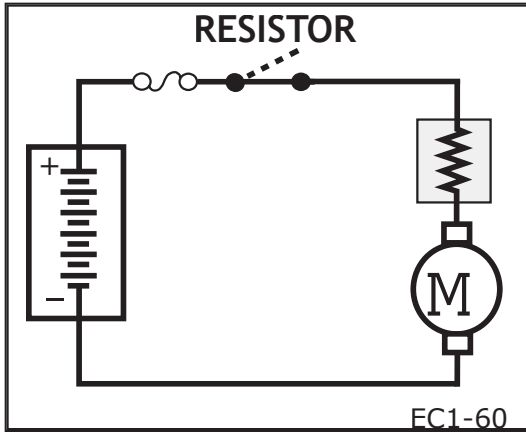

ACTIVITY

Functions of Resistors

Any device in a circuit that presents a resistance to current flow and produces a voltage drop can be considered a resistor. Often, there will be a need to reduce the voltage in a circuit to a specific value. For this purpose an electrical device known as a resistor can be placed in the circuit. The resistor drops the voltage by converting some of the electrical energy into heat. Resistors can be classified as fixed or variable and are available in a variety of different resistance values and wattage.

Build the circuit shown in the picture below and describe its operation when the resistance value is changed.

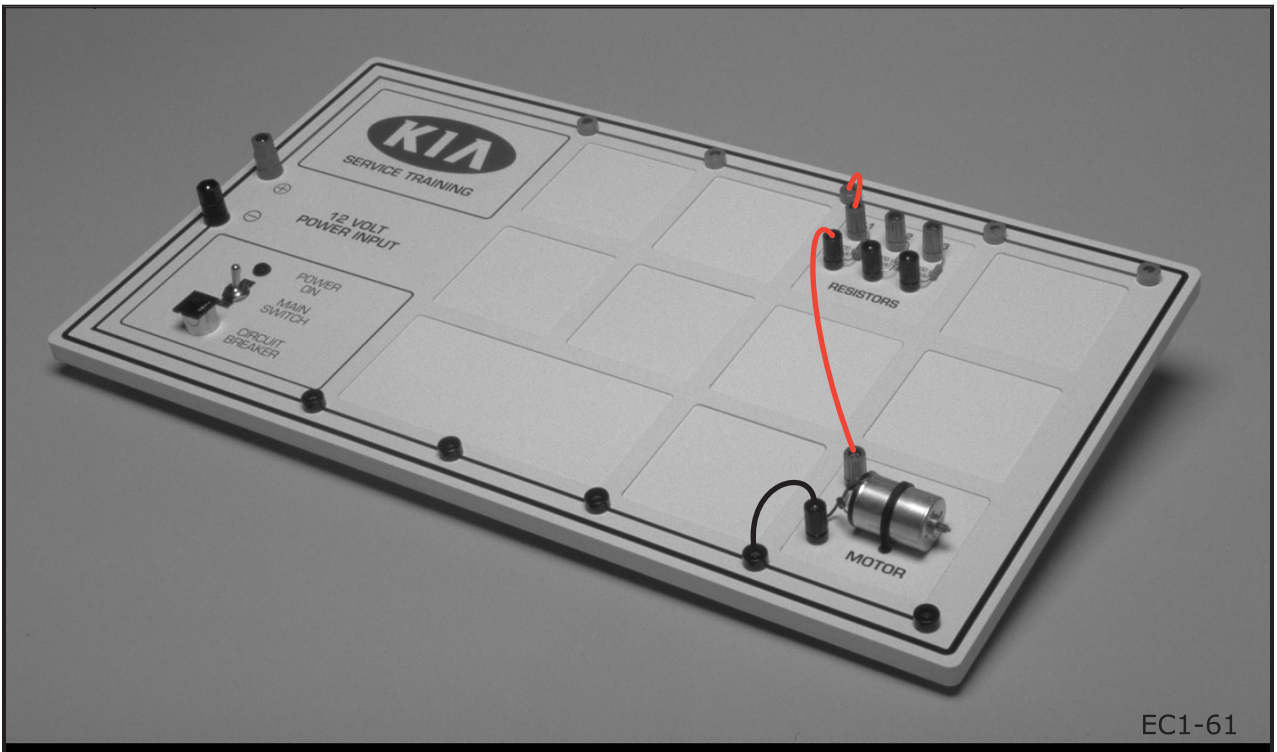

- Diodes
- Transistors

EC1-62

ELECTRONIC CIRCUIT CONTROL METHODS

With the advancements in today's technology the automobile has become much more complex. Computerized systems consisting of electronic or solid state devices are now being used to control emissions, deploy airbags, monitor engine operation, control alarm systems and many other operations taking place in the vehicle. The most common of the electronic control devices that the technician may become involved with are diodes and transistors. These devices are known as semiconductors.

- Part conductor; part insulator
- Usually made of silicon or germanium
- Can be N-Type or P-Type
- When joined together current can move only in one direction

EC1-63

Semiconductors

A semiconductor is a solid material whose electrical conductivity at room temperature lies between that of a conductor and that of an insulator. At high temperatures its conductivity approaches that of a metal and at low temperatures it acts as an insulator.

The elements silicon and germanium are typically used as semiconductor material. Both have only 4 electrons in their outer valence shell. When certain impurities such as arsenic, bismuth or antimony, which have 5 electrons in their outer shells, are alloyed with them the resultant material becomes an **N-Type** material. N-Type semiconductors have extra electrons free to move about so they are called donors.

When silicon or germanium is alloyed with boron, indium or gallium, which have only 3 electrons in their outer shells, there will be holes formed in the outer ring which will accept electrons from an outside source. The material is now a **P-Type** material and is an acceptor.

The N-Type materials are negative charged and the P-Type materials are positive charged. Just like magnets, the "likes" repel and the "opposites" attract.

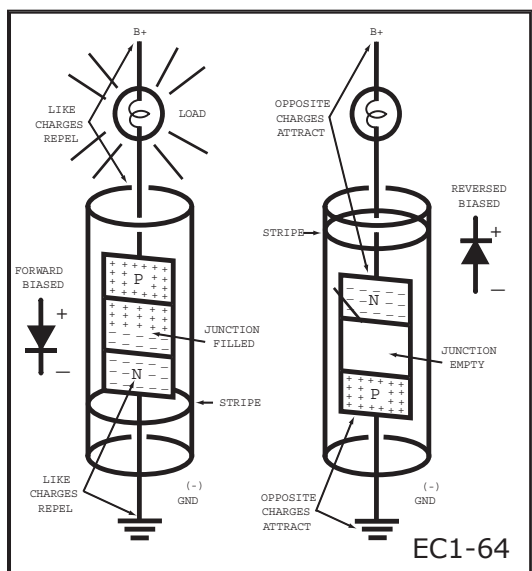

EC1-64

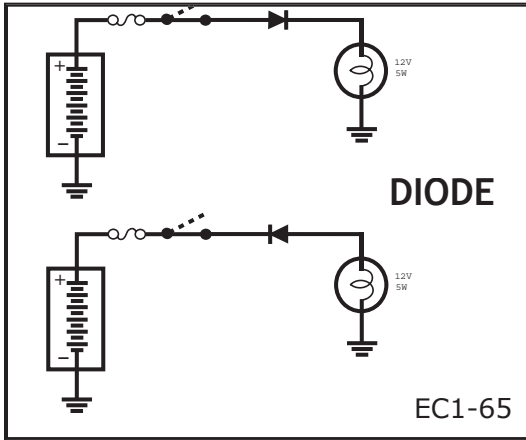

ACTIVITY

Functions of Diodes

A diode is a semiconductor device with one N-Type and one P-Type material joined together which allows current flow in one direction only. It can be compared to a check valve which permits a fluid to pass in one direction and stops it in the other. The most common place that the automotive technician will find the use of diodes is in the alternator to rectify or change the AC voltage into DC voltage. A diode is also used in the alternator to prevent the battery from discharging back through the windings in the alternator.

Using the diode, Switch 1 and Lamp L2, build the circuit shown in the picture below and describe its operation. Reverse the connections to the diode and check again.

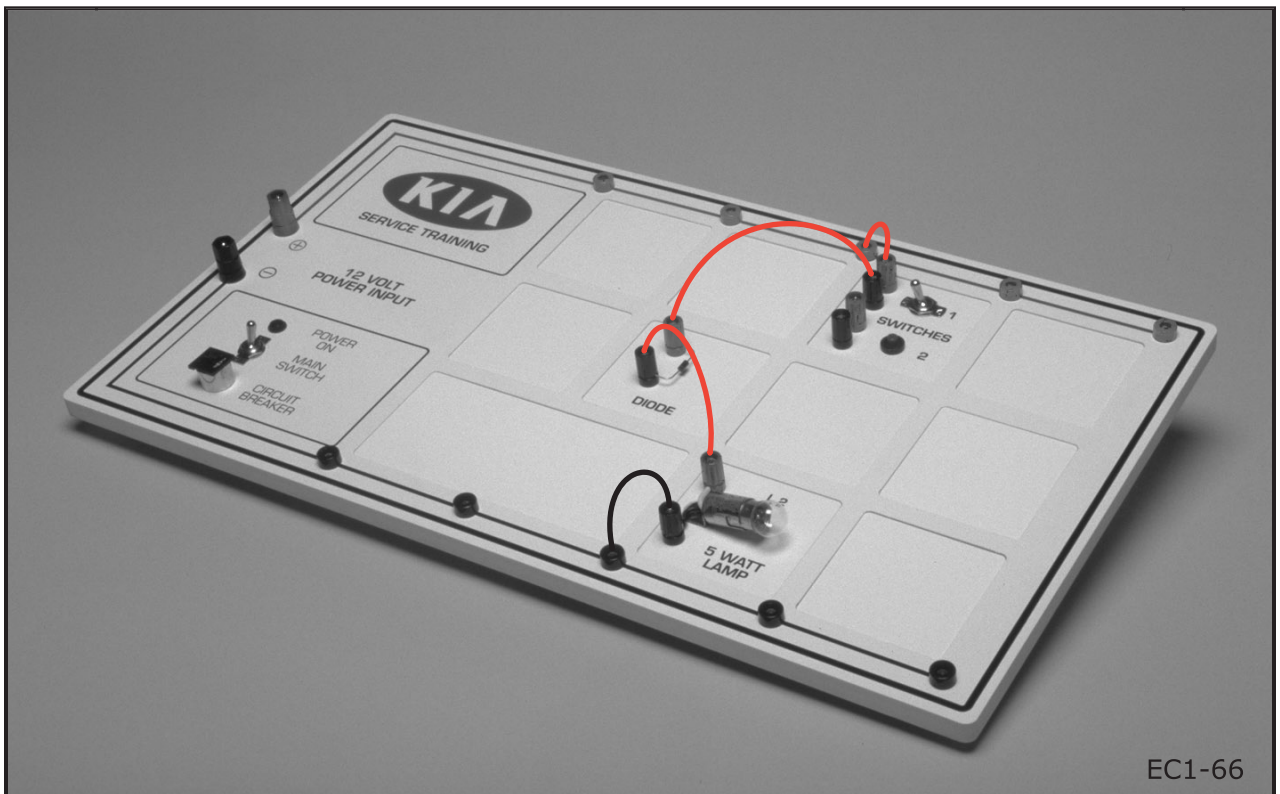

EC1-66

Functions of Transistors

A transistor is similar to a diode in that it uses N-Type and P-Type materials but rather than check the flow of current the transistor can control the flow of current much like a relay.

The transistor is essentially a sandwich of N-Type material between two pieces of P-Type material or a P-Type material between two N-Type materials. The center piece is extremely thin and is called the base and is the control element of the transistor. One end piece is the emitter and the other is the collector. When current is allowed to pass through the base, the emitter and collector materials react and allow current to pass through them.

TRANSISTOR

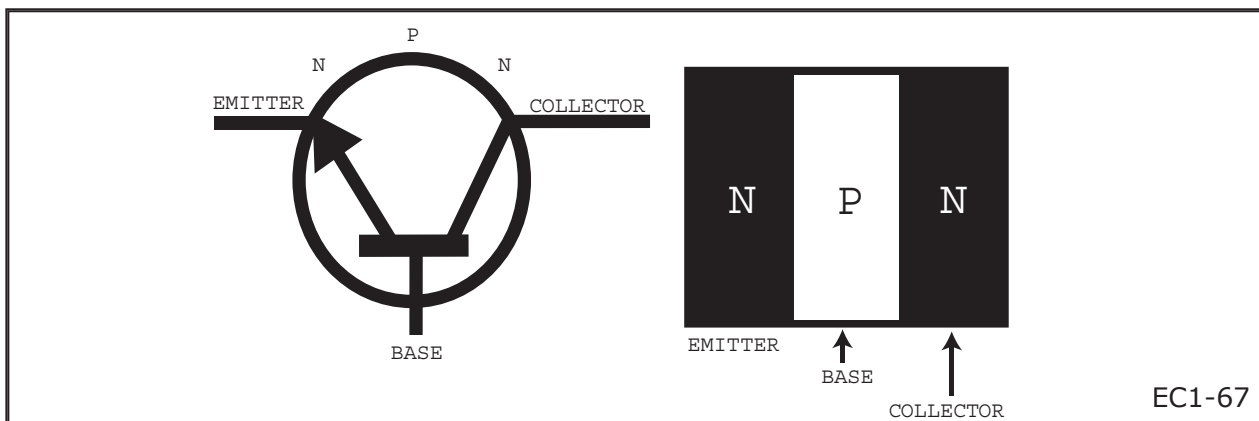
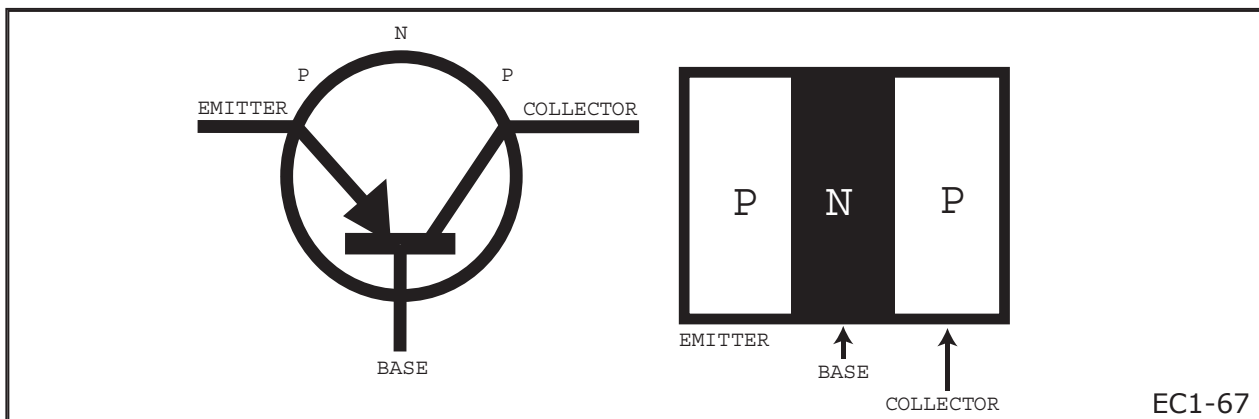

ACTIVITY

SI	LAMP	A ₁	A ₂
OFF			
ON			

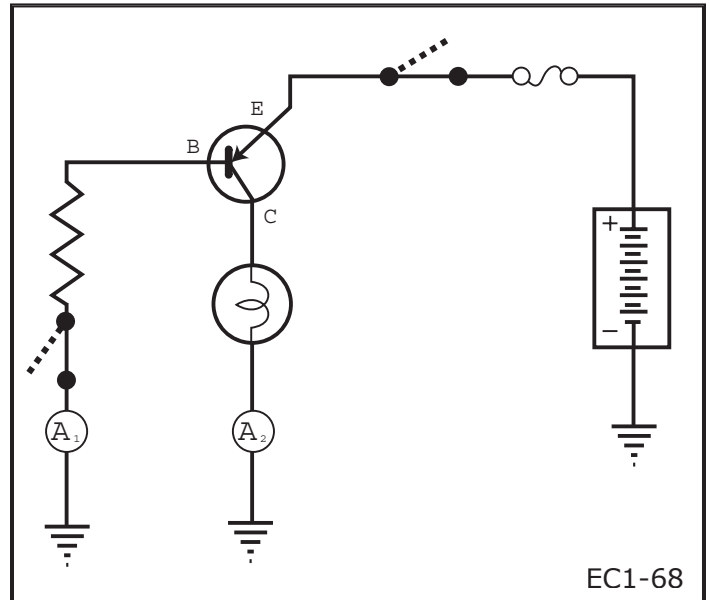

EC1-68

Using the PNP transistor, Switch 1 and Lamp L2, build the circuit shown in the picture below and describe its operation.

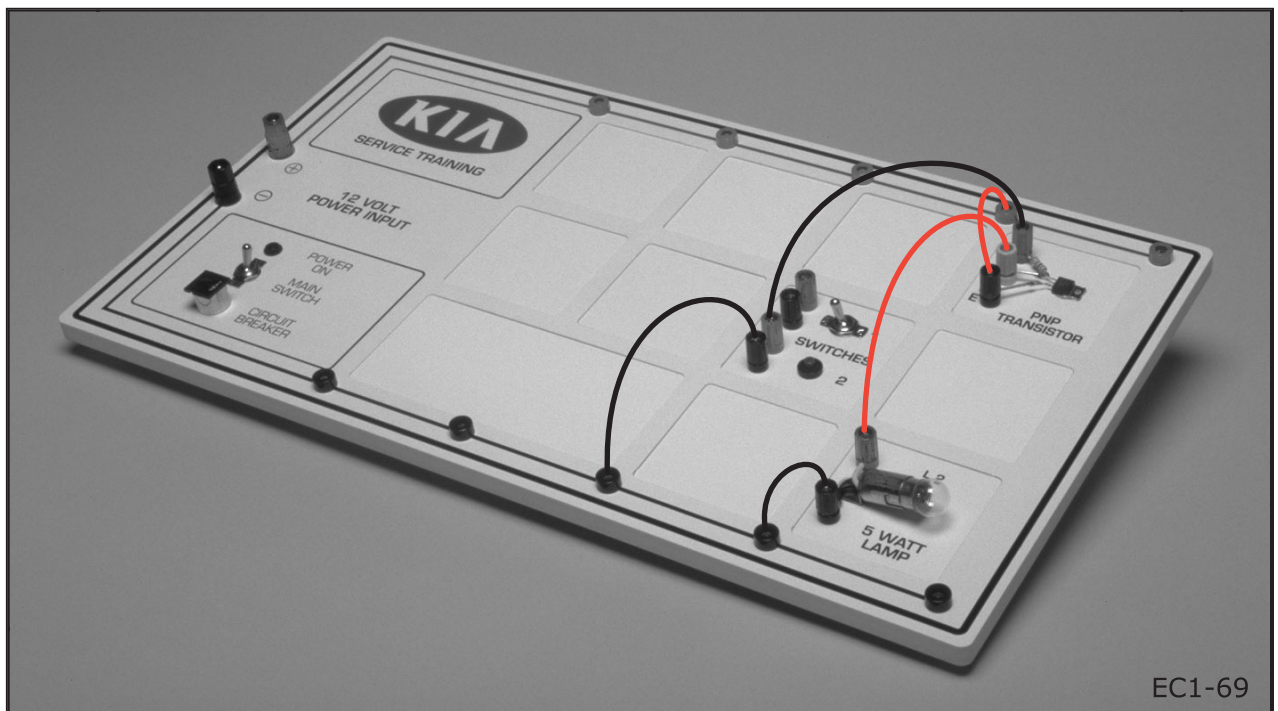

EC1-69

INSPECTION OF PNP TRANSISTOR

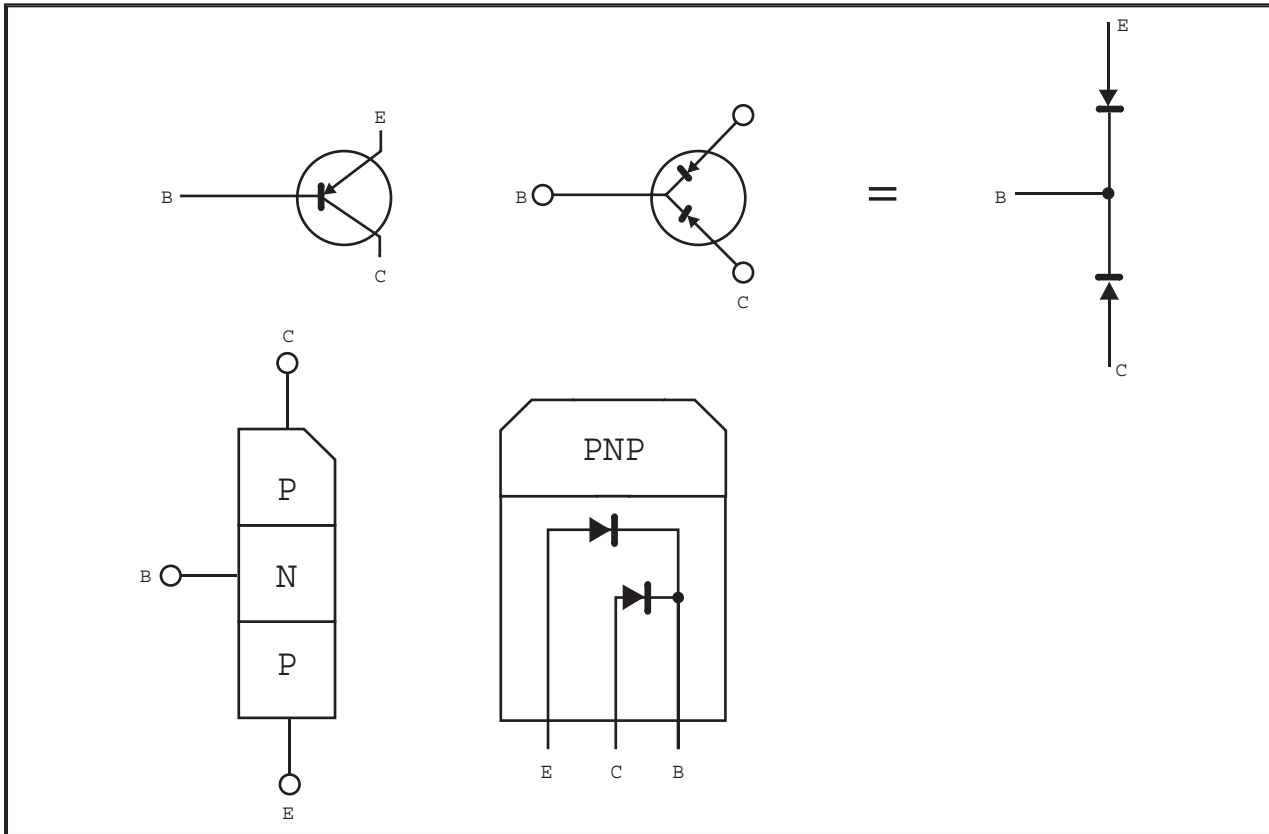

POSITIVE (RED)	NEGATIVE (BLACK)	CONTINUITY
B	E	NO
B	C	NO
E	B	YES
C	B	YES

ACTIVITY

SI	LAMP	A ₁	A ₂
OFF			
ON			

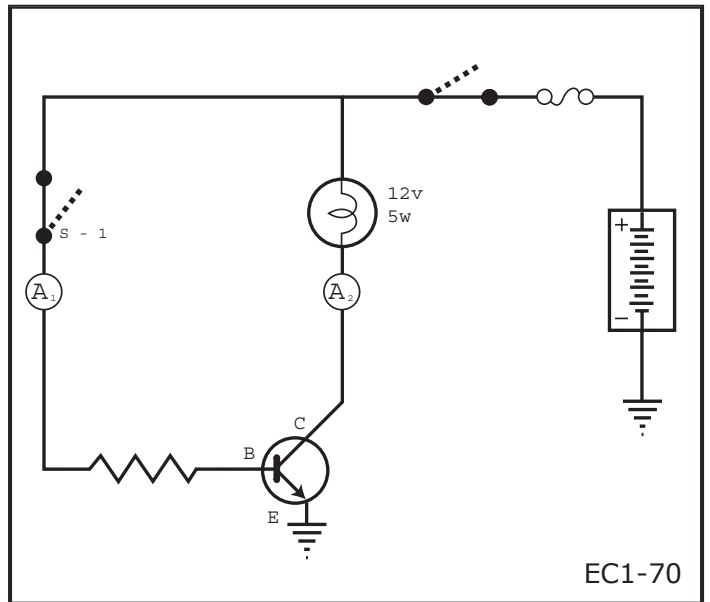

Using the NPN transistor, Switch 1 and Lamp L2, build the circuit shown in the picture below and describe its operation.

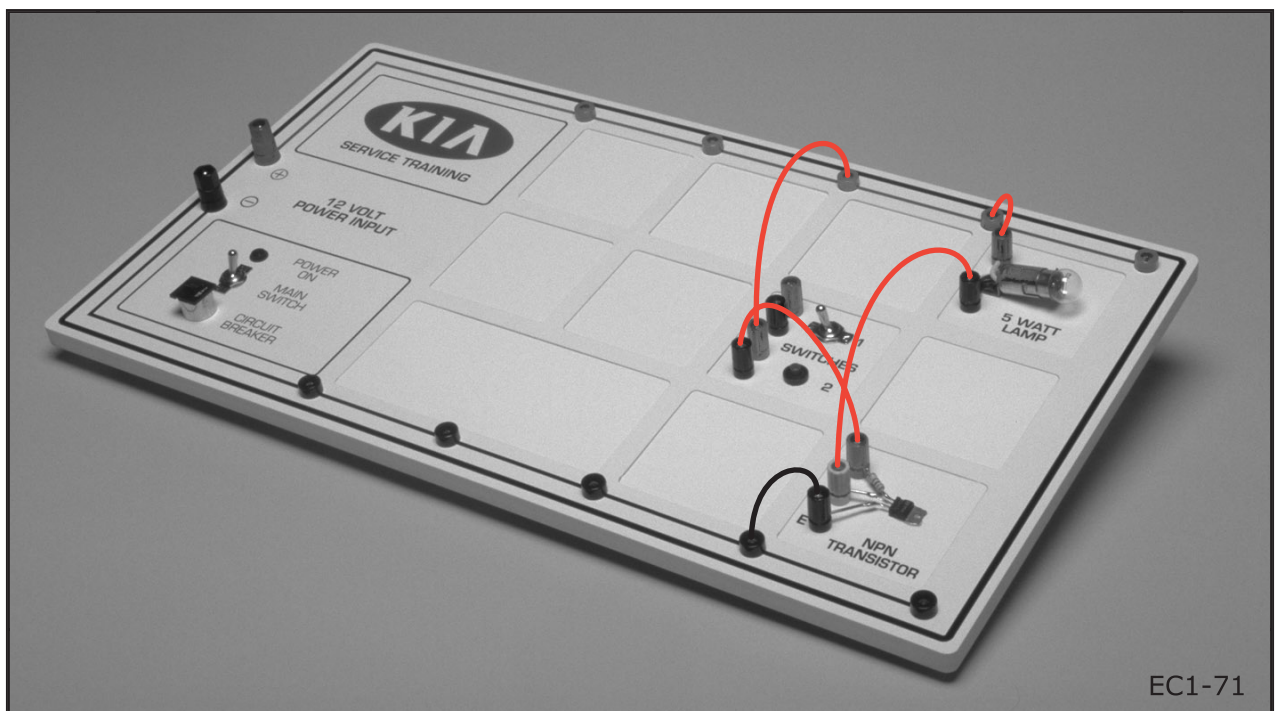

INSPECTION OF NPN TRANSISTOR

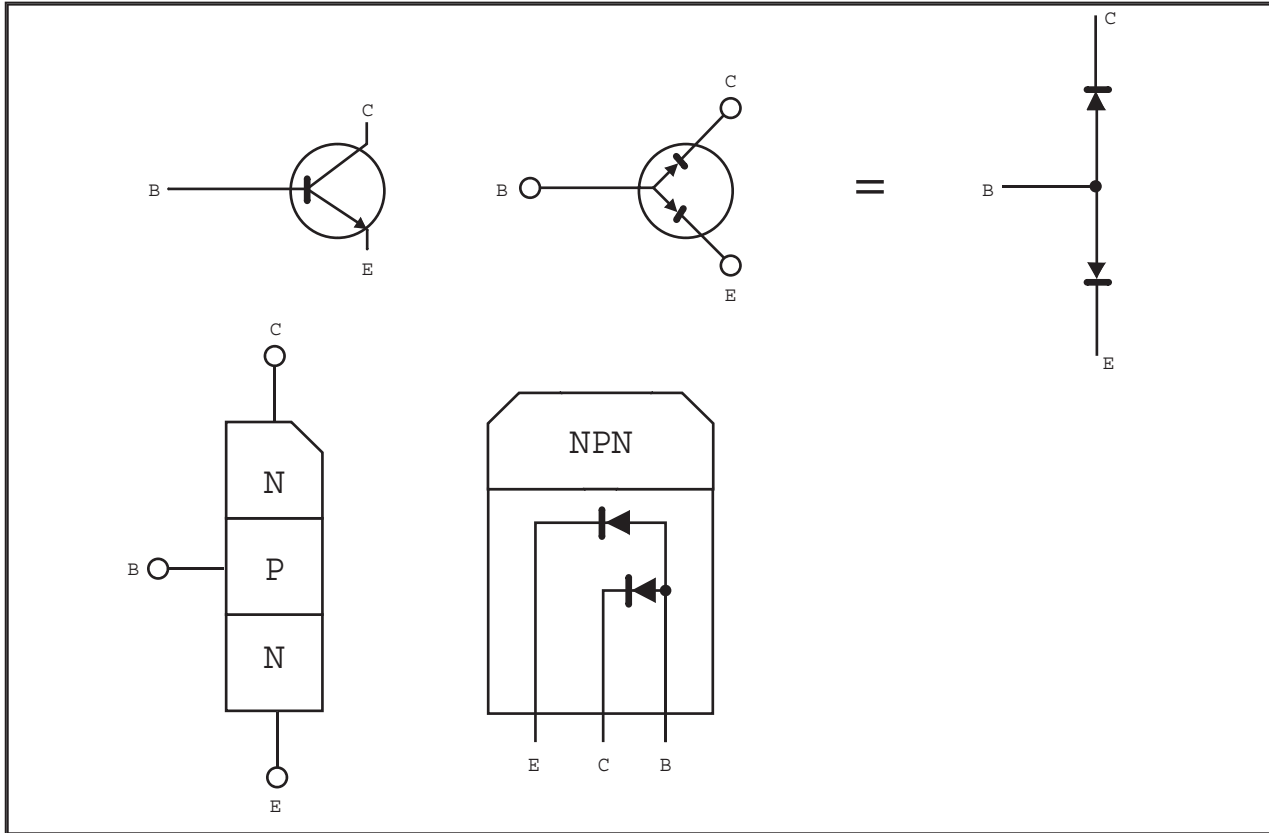

POSITIVE (RED)	NEGATIVE (BLACK)	CONTINUITY
B	E	YES
B	C	YES
E	B	NO
C	B	NO



SELF-TEST

This self-test will enable you to measure the knowledge that you have gained about Automotive Electrical Circuit Analysis. Circle the one best answer that completes the statement or answers the question.

1. Which of the following is a load device?
 - a. Battery
 - b. Circuit breaker
 - c. Blower motor
 - d. Fog lamp switch
2. Which of the following circuits is an example of a series-parallel circuit?
 - a. Instrument panel lights
 - b. Back-up lights
 - c. Horn
 - d. Headlamps
3. Technician A says that all working circuits must have a power source, a load device and a ground.

Technician B says that most automotive circuits have a control device.

Who is correct?

- a. Technician A only
- b. Technician B only
- c. Both A and B
- d. Neither A nor B

FEEDBACK

4. As the resistance in a 12-volt automotive circuit increases, what happens to current flow in the circuit?
 - a. It stops
 - b. It decreases
 - c. It increases
 - d. Nothing
5. When current is allowed to pass through the base of a transistor, the emitter and collector materials react and allow current to pass through them.
 - a. True
 - b. False
6. What happens to the total current in a parallel circuit, when one of the branches are removed?
 - a. Stays the same
 - b. Goes up
 - c. Goes down
 - d. Changes to equal the resistance
7. What law of electricity states that the current that flows in an electrical circuit is directly proportional to the voltage and inversely proportional to the resistance in the circuit?
 - a. Coulomb's Law
 - b. Kirchoff's Law
 - c. Ohm's Law
 - d. Faraday's Law



NOTES



WE SUPPORT
VOLUNTARY TECHNICIAN
CERTIFICATION THROUGH

National Institute for
**AUTOMOTIVE
SERVICE
EXCELLENCE**

No part of this publication may be reproduced, stored electronically, or transmitted in any form or by any means without prior written approval from Kia Motors America, Inc. KMA reserves the right to make changes in the descriptions, specifications or procedures without prior notice or obligation.

Copyright © 1999 Kia Motors America, Inc. Corporate Service Training Department



ED1

Student Learning Guide

Electrical Diagnosis

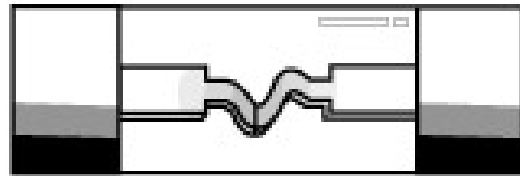
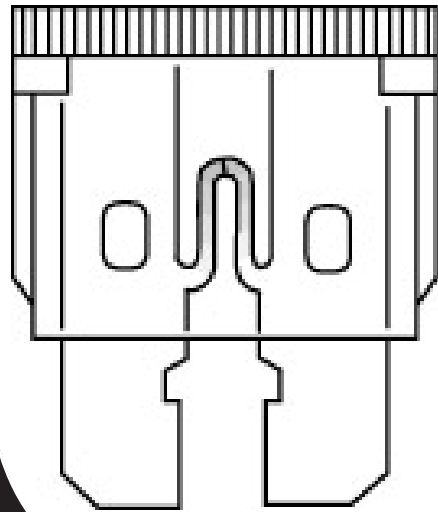

**Automotive
Electrical Course**



S E R V I C E T R A I N I N G



After completing this module, you will be able to use a good diagnostic thought process to identify the correct sequence of steps to follow when diagnosing and repairing a Kia vehicle.

This will enable you to diagnose and repair system or component problems faster and more effectively.

LEARNING OBJECTIVES

- Use a good diagnostic thought process when diagnosing and repairing system or component problems
- Identify the Kia 5 Step troubleshooting process
- Use voltage drop testing to isolate circuit faults
- Use a DVOM and an Electrical Troubleshooting Manual to diagnose a parasitic current draw problem

ED1-1

MODULE DIRECTIONS

Carefully read this material. Study each illustration as you read the material. Feel free to ask questions any time something is not clear. Be sure to answer the questions in the activity and at the end of the module.

WHAT YOU WILL NEED

- One red marker
- One green marker
- Digital Multimeter
- 1999 Sephia or Sportage

- Not simply following steps
- Thinking critically about malfunctioning system and discovering reasons for problems
- Eliminate obvious problems before opening tool box
- Follow Kia 5 step troubleshooting process

ED1-2

1. Verify the problem
2. Analyze the problem
3. Find the cause
4. Repair the problem
5. Check the repair

ED1-3

- Normal or abnormal?
- Be sure that you understand the problem
- Experience the problem first hand with the customer present
- Don't start disassembly or testing until problem area has been narrowed down
- Check for malfunction indicator lights

ED1-4

DIAGNOSTIC THOUGHT PROCESS

Diagnosis is more than simply following a series of steps to solve a specific problem. Diagnosis is a thought process that causes you to look at a system that is not functioning properly and discover the reasons. If you use a good diagnostic thought process, many possible causes can be eliminated before you even open your tool box. In this module, you will learn to develop good habits by following the Kia 5 step troubleshooting process.

Five Step Troubleshooting Process

Effective diagnosis requires knowledge of how a system is supposed to operate in order to determine when it is not operating correctly.

There are five basic steps for diagnosis and repair. If you follow these steps in a systematic manner, you will usually find the cause of the problem the first time.

VERIFY THE PROBLEM

Get an accurate description of the customer's complaint. Determine if the concern is a normal condition or a valid failure. Sometimes a valid complaint exists, but the customer may describe the problem in a way that leads you down the wrong diagnostic path.

Note the symptoms, but do not begin disassembly or testing until you have narrowed down the problem area.

Check to see if any warning or malfunction indicator lights are on.



Whats, Whens and Hows

- What is the vehicle model?
- What accessories (including aftermarket) are installed?
- What systems do not operate? What systems do operate properly?
- When does the problem occur?
- How long has the problem existed and was it ever correct?
- How does the problem occur? (what conditions)
- How often does the problem occur?

ED1-5

Before starting on a problem get as much information as possible about the problem. Sometimes problems in one system may cause another system to operate erratically or not operate at all.

Often an operational check, including a roadtest with the customer is helpful.

ANALYZE THE PROBLEM

- Eliminate the obvious
 - Previous repairs
 - Collision
 - Vehicle use problems
 - Add on accessories

ED1-6

Once you have verified that a legitimate problem exists, you must determine whether it is related to some other obvious problem such as previous repairs, an accident or an add-on aftermarket equipment such as a car alarm or audio system.

If you are satisfied that it is a system problem, it is time to make some preliminary checks.

Preliminary Checks

- Check for unusual conditions (appearance, odors, noise, vibration or leaks)
- Retrieve diagnostic trouble codes, pending codes and freeze frame data
- Visually inspect for loose connections or burnt wiring
- Check for blown fuses
- Check the operation of the suspect system
- Investigate the vehicle's history
- Check service manual for possible causes
- Review all schematics for the problem system
- Look for applicable Technical Service Bulletins and Newsletters

ED1-7

Do the preliminary checks. Based on the symptoms and your understanding of the systems operation, identify one or more possible causes. Use the troubleshooting information in the Service Manuals and ETMs as a guide.

- Analyze the possibilities
- Prioritize the possibilities
- Use the Service Manual and/or ETM to determine the connection that is easiest to access and will provide the most useful information
- Perform the tests and inspections listed in the Service Manual and/or ETM

ED1-8

FIND THE CAUSE

Formulate a simple and logical procedure to diagnose the condition. Check the diagnosis you made by doing tests. Test for the most likely cause of failure first. Isolate electrical circuits.



REPAIR THE PROBLEM

- Replace parts using the recommended Service Manual procedures
- Replace connectors and wire terminals using recommended procedures described in the ETM
- Use genuine Kia replacement parts

ED1-9

Once the specific problem is identified, make the repair following all recommended repair procedures in the service manual and/or ETM.

CHECK THE REPAIR

- Recheck, evaluate results
- Check related systems for proper operation
- Check for any new problems

ED1-10

Verify that the repair corrected the problem by performing the system checks under the conditions documented in the customer complaint. Operate any related systems. Make sure no new problems turn up and the original problem does not recur.

- High Resistance Faults
- Low Resistance Faults
- Component Faults

ED1-11

- Open circuit
- Dirty connections
- Corroded connections
- Will not cause blown fuse

ED1-12

The two methods for locating an open in a circuit are:

- Voltage Test
- Continuity Test

ED1-13

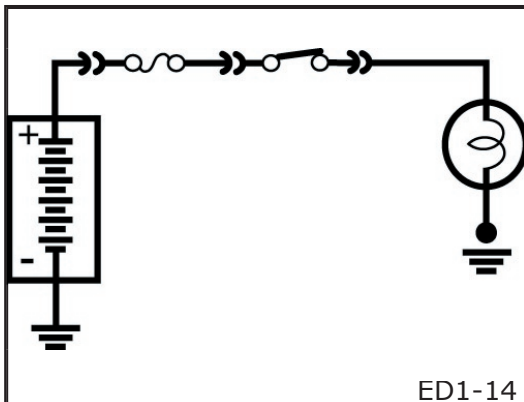

ED1-14

ELECTRICAL SYSTEM MALFUNCTIONS

All electrical malfunctions can be categorized in one of three types of faults: high resistance, low resistance or component.

High Resistance Faults

Referring back to Ohm's Law, we know that when resistance in a circuit increases the available current will decrease. High resistance in a circuit can be caused by an open in the circuit or a loose, dirty or corroded connection. In order for the circuit to have current flow a complete path is needed. An open in the circuit will stop current flow and unwanted resistance will reduce the current flow. High resistance problems are very common and often overlooked when doing electrical diagnosis. When lamps flicker or motors run slow check the connections in the circuit for being loose, dirty, or corroded. Normally, a high resistance fault does not cause the fuse to blow.

DIAGNOSING AN OPEN CIRCUIT

To discover the location of an open in a circuit two methods can be used: a **voltage test** or a **continuity test**.

Voltage Test

The voltage test can be done using either a test lamp or a digital volt meter. Start by checking for the proper voltage at the power source. Connect the negative lead of the test lamp or volt meter to a known good ground. Then connect the positive lead to the point where you want to check. If the proper voltage is present move the test lamp or volt meter to the next point along the conductor where a device or connector is located and check for voltage again. Continue to move along the conductor until no voltage is detected. The open will be located between the last two points checked.

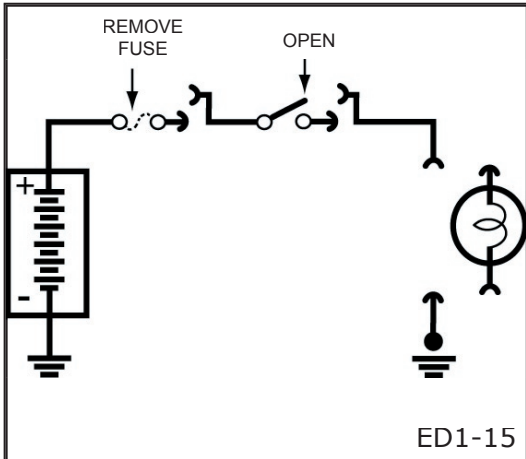

Continuity Test

The continuity test is nothing more than just checking for a continuous path for the current to flow. The best tool for this test is the ohmmeter. With the ohmmeter you will also be able to locate areas of high resistance. The circuit or component should be isolated or removed from the power source prior to testing. Connect the ohmmeter to the circuit or component with the positive lead at one end and the negative lead at the other. Polarity will only matter if a diode is in the circuit. Check to see if the resistance measurement is within specification. If the resistance is high or an "OL" (out of limits) reading is obtained continue to take measurements while shortening the circuit down until the problem area or component is found.

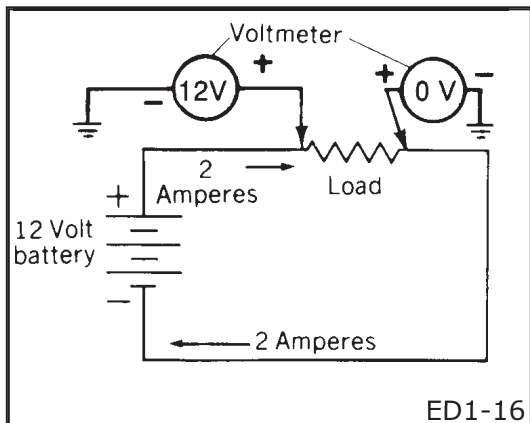

VOLTAGE DROP

As current flows through a resistance, electrical energy is converted to other forms of energy such as heat, light or motion.

The effort of pushing electrons through a resistance uses up voltage. This reduction in voltage is called voltage drop. In automotive circuits even the smallest loss of voltage will cause poor performance.

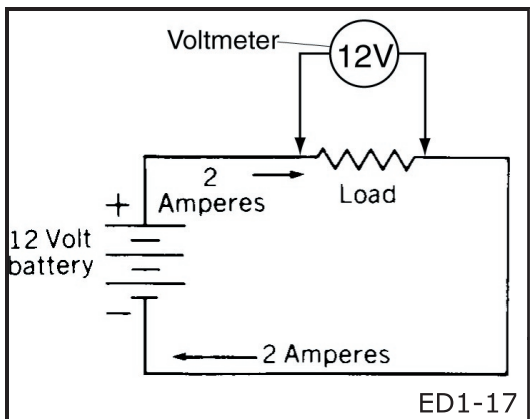

Voltage drop is the difference between the voltage on the power side of a load (applied voltage) and the voltage on the ground side (closest to the negative battery terminal). In most cases voltage drop tests are recommended over resistance checks because you are measuring the circuit while it is in operation.

You can measure the resistance through the starter cable and as long as one strand of wire is complete the resistance will be within specifications. But, after applying power to the circuit and measuring the voltage drop, it becomes more evident that there is a problem in the circuit.

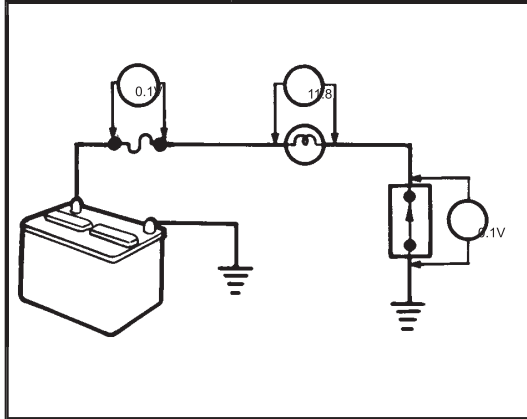

Diagnosing Using Voltage Drop

When you measure the voltage drop across a load, you are measuring the actual voltage applied to that load.

Voltage drop occurs whenever current flows through a resistance. There is no voltage drop without current flow.

The sum of all of the voltage drops in a circuit, will always be equal to the source voltage.

In a multi-device circuit, if the voltage drop across any one device is equal to the source voltage, the device has an open circuit because no voltage is being consumed.

If the voltage drop across any one load device is zero, the load device is shorted and is either not consuming voltage or there is no voltage drop because there is no current flow in the circuit.

Voltage drops should not exceed the following:

200mV	Wire or cable
300 mV	Switch
100 mV	Ground
0mV to <50mV	Sensor connections
0.0V	Connections

Voltage drops should not exceed the following:

200mV	Wire or cable
300 mV	Switch
100 mV	Ground
0mV to <50mV	Sensor connections
0.0V	Connections

ED1-18a

On longer wires or cables, the drop may be slightly higher. In any case, a voltage drop of more than 1.0 volt usually indicates a problem.

Diagnosis Procedure

1. Connect the positive lead of a voltmeter to the end of the wire (or to the side of the connector or switch) closest to the battery.
2. Connect the negative lead to the other end of the wire (or the other side of the connector or switch).
3. Operate the circuit.
4. The voltmeter will show the difference in voltage between the two points. A difference, or "voltage drop" of more than 0.1 volt, may indicate a problem.

DIAGNOSING HIGH RESISTANCE FAULTS

High resistance malfunctions result in reduced or improper operation of the circuit. Suspect a high resistance malfunction if a bulb turns on but remains dim or a motor

- Result in reduced or improper operation
- Usually caused by loose or corroded connections
- Voltage drop should be nearly zero across control device or connection

ED1-19

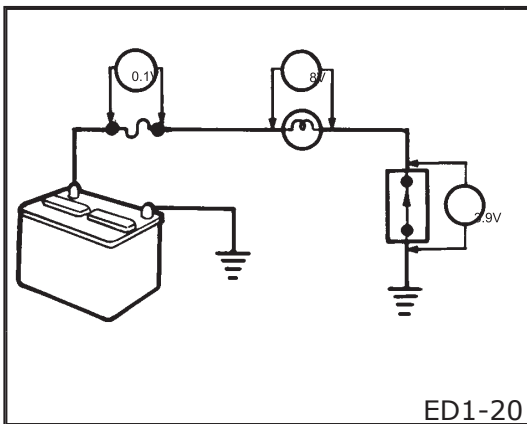

ED1-20

- Too much current flow
- Wire shorted to ground
- Wire to wire short
- Check part installation
- Will blow fuse or open breaker

ED1-21

operates at a reduced speed. Loose connections, corrosion and partially broken wires are likely to cause high resistance in a circuit. Voltage drops across a control device or connection should be ideally zero if not very low.

Using Voltage Drops to Find High Resistance

When you compare this circuit to the normally operating circuit on the previous page, you will see the effect that high resistance has on a circuit.

The switch in this circuit has dirty contacts which causes the voltage drop across the switch to be 3.9 volts as opposed to the 0.1 volt drop across the switch in the normally operating circuit.

Notice also that because the switch is dropping 3.9 volts and the fuse contacts are dropping 0.1 volt, there are only 8 volts left to operate the bulb. In this circuit the bulb would burn dimmer than normal.

High resistance is very critical in ECU controlled circuits because the reference voltage is only 5 volts. High resistance in an ECU controlled circuit can cause false readings from sensors and may even prevent the circuit from operating.

Low Resistance Faults

A low resistance fault will allow too much current flow or current to flow to a portion of the circuit where it does not belong. The low resistance can be caused by a short to ground or a short to another circuit. Check for bare wires touching to ground or to other wires. Also be aware that sometimes an aftermarket accessory may have been installed incorrectly. Usually a fuse will blow or a circuit breaker will open because the low resistance condition increases the current flow in the circuit to more than the circuit is capable of handling.

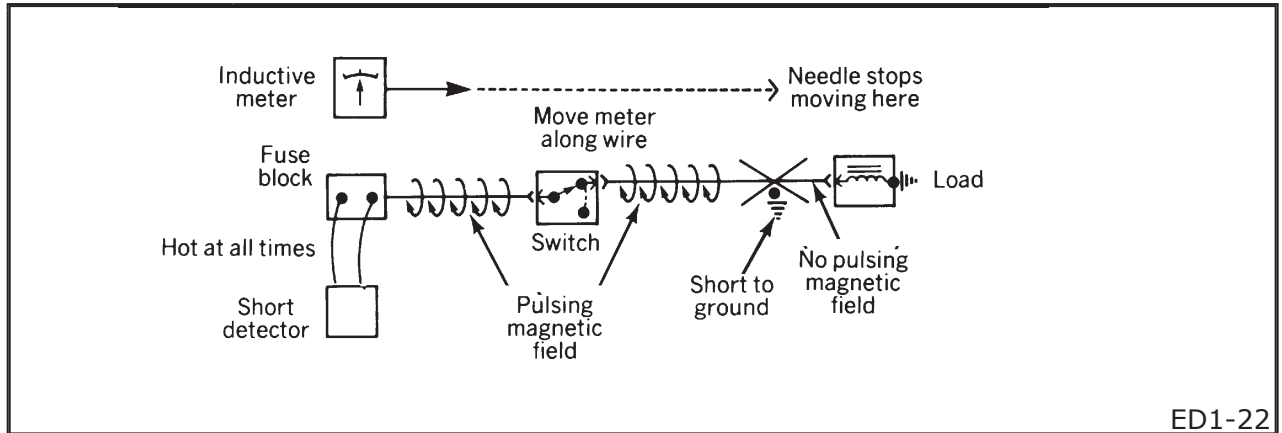

DIAGNOSING SHORT CIRCUITS

Short circuits that result in excessive current flow will normally blow the circuit protection device. Because the circuit will not operate, voltage drop tests cannot be made.

There is a commercially available short detector that pulses current intermittently through the shorted circuit. An inductive ammeter, included with the kit, traces this flow of current through the faulty circuit. The ammeter needle will move with each of the current pulses as it is moved along the circuit. When it gets to the short, the needle will stop.

The most common use for this tester is for wiring harness shorts to ground.

PARASITIC DRAW

Parasitic current draw flows when all the switches on the vehicle are in the off position. A small amount of current is necessary to enable the various electronic control units and alarm systems to retain their programming when the ignition switch is turned off.

Parasitic current draw is normally less than 20 milliamps but may be higher with an aftermarket alarm system installed.

- Flows when all switches are off
 - Necessary to retain computer memory
 - Above 20 milliamps may indicate a problem
- ED1-23

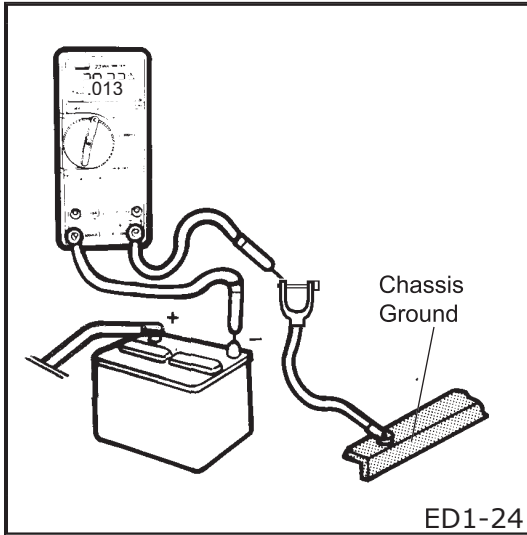

Diagnosing a Parasitic Draw Problem

When parasitic draw exceeds approximately 20 milliamps (100 milliamps with aftermarket alarm), it may be an indication that the vehicle's electrical system has a grounded circuit that is bypassing its control device. This can cause the vehicle battery to discharge over a period of time.

Parasitic current draw is measured by turning OFF all accessories, closing all the doors, the trunk, etc. and connecting an ammeter between the negative battery cable and the negative battery post as shown in the illustration.

Diagnosis Procedure

1. Connect ammeter to battery cable and battery negative post
2. Refer to Power Distribution in ETM
3. Remove one fuse or fusible link at a time until the ammeter reading is normal

ED1-25

Connect the red lead to the battery cable and the black lead to the battery negative post.

If the current reading on the meter exceeds 50mA (100mA with aftermarket alarm), refer to the Power Distribution Schematic Diagram in Section 10 of the Electrical Troubleshooting Manual (ETM) and remove one fuse or fusible link at a time until the ammeter reading is normal.

Once the malfunctioning circuit has been identified, refer to the Circuit Diagram for that circuit to further isolate the problem to the wiring or a circuit component.

CAUTION

Always start measuring with the ammeter on the highest scale and work your way down to prevent damage to the meter.

ED1-26

Excessive Current

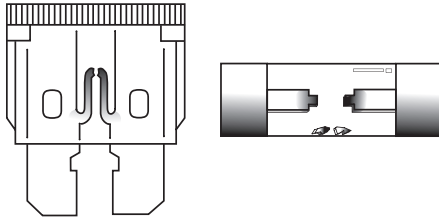

ED1-27

Fatigue

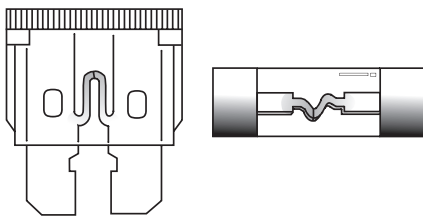

ED1-28

Poor Contact

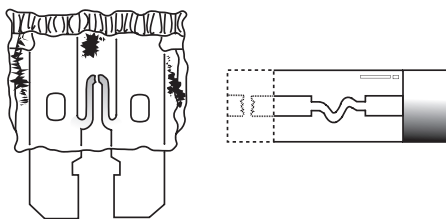

ED1-29

FUSE FAILURES

A fuse will normally fail for one of three reasons: excessive current in the circuit, fatigue or poor contact. By inspecting the failed fuse we can often determine the cause of the failure.

- Excessive current can be caused by a short circuit or by an excessive load being imposed on a motor. Examples:
 - Wiper blade frozen to the windshield
 - Window too tight in the runner

A fuse that has failed due to excessive current will have a 2 to 3mm section melted away at the center. The circuit and components should be checked and any repairs needed should be done prior to replacing the fuse.

- Fuse fatigue is caused by the fluctuations in current when the power is switched ON and OFF. The ON/OFF current will heat and cool the fuse and eventually the fuse will burn out.

A fuse that has failed due to fatigue will look like the center of the fuse was cut with a thin knife.

- Poor contact between the fuse and the fuse holder causes resistance which generates heat. If the fuse gets too hot it burns and fails.

On bladed fuses the plastic may melt and the element will melt much like with excessive current. On tube fuses, the contacts at the cap to element will melt. Prior to replacing the fuse, the holder should be cleaned and repaired to provide better contact with the fuse.



- Less common in today's vehicles
- Possible defective part
- Worn part
- Adjustments
- Battery charge

ED1-30

Component Faults

Probably less common in today's vehicles due to the increase in quality but it is certainly possible to have a defective electrical part. Also, electrical parts do wear out and require replacement or adjustment and batteries lose their charge.

Simplifying Schematic Diagrams

Before you jump into an electrical problem, take a few moments to study the electrical troubleshooting manual. Some of the schematic diagrams look pretty complicated because several circuits are shown on the same diagram, but if you take the time to break them down they will save you time in the long run.

Follow the steps shown in the illustration to break down a complex diagram into small bite-size chunks.

On the following pages, you will have the opportunity to use these steps to diagnose a problem that you may experience in your shop.

- Locate the correct ETM for the vehicle
- Look in the table of contents to determine the circuit most likely to be at fault
- Locate the correct Circuit Schematic Diagram
- Trace the power side of the circuit
- Trace the ground side of the circuit
- Identify the circuit protection devices, load devices and circuit control methods used
- Eliminate portions of the circuit that you know are working properly
- Identify the connectors and their locations
- Locate a most accessible test point that will give you the most information
- Perform the tests necessary to isolate the problem
- Compare test results with predicted values or specifications
- Continue testing until problem is found or normal operation is confirmed

ED1-31,
32, 33

INDICATORS AND GAUGES CLUSTER

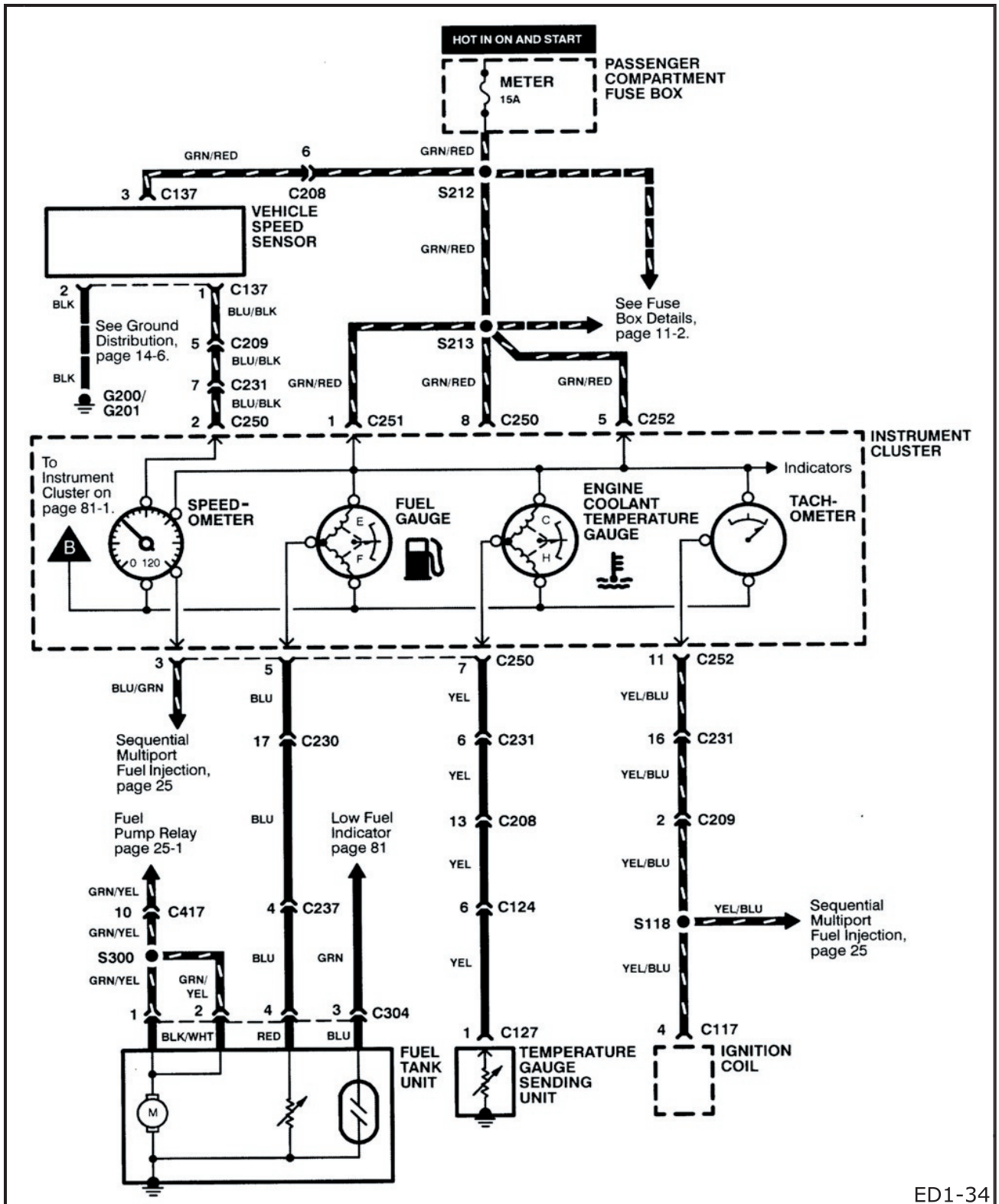

ED1-34



ACTIVITY

DIAGNOSTIC EXAMPLE

Follow the steps in this activity using the schematic diagram shown in the illustration. Answer the questions in the space provided.

The owner of a 1996 Sportage stated that the coolant temperature gage does not work.

You have verified the problem and found that all of the other gauges are working OK.

You have located the INDICATORS AND GAUGES CLUSTER diagram in the ETM and are ready to analyze the problem.

1. Trace the power side of the coolant temperature gauge circuit with a red marker.
2. Trace the ground side of the circuit with a green marker.
3. Identify the following components:

Load Devices: _____

Control Devices _____

Protection devices _____

Since the other gauges worked OK, all of the wiring from the ignition switch to terminal #5 of connector C252 is good.

This limits the suspect area to the gauge and the ground return path through the sending unit.

You have just reduced a complex diagram to a small section without even opening your tool box.

Now you can isolate the problem by dividing the circuit at the easiest point where you will get the most useful information, in this case connector C127, and continue your diagnosis.

ACTIVITY

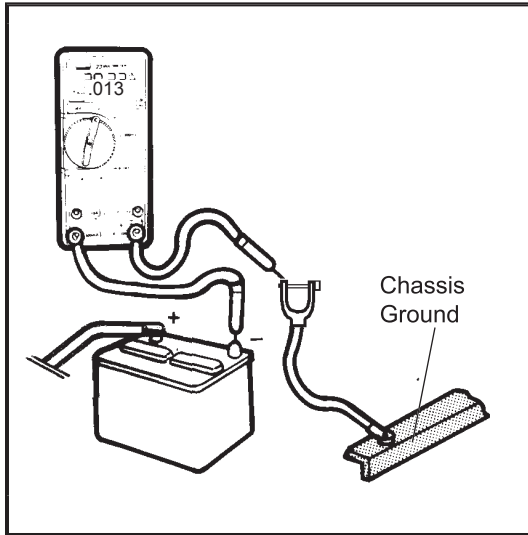

CURRENT FLOW MEASUREMENT

1. Disconnect the negative battery cable.
2. Connect the multimeter between the negative battery terminal and the negative battery post.
3. Close all doors, trunk, etc.
4. Measure the parasitic current draw.
Multimeter reading _____ amps
5. Select the 20 Amp range on the multimeter.
6. Open the driver's door.
7. Check the dome light switch to ensure it is in the "door" position.
8. Measure the parasitic current draw
Multimeter reading _____ amps
9. Close the driver's door. The ammeter should return to the reading you had in step 4.
10. Connect the negative battery cable.

ACTIVITY

VOLTAGE DROP MEASUREMENT

A vehicle comes into your shop with the complaint that the passenger compartment dome light glows dim. The customer states that the bulb has been replaced but the condition remains.

Diagnose this problem using voltage drop. In the space provided to the right explain what you did to locate the problem and what is causing the problem.



FEEDBACK

SELF-TEST

This self-test will enable you to measure the knowledge that you have gained about Diagnostic Techniques. Circle the one best answer that completes the statement or answers the question.

1. Diagnosis is simply following a series of steps to solve a specific problem.
 - a. True
 - b. False
2. Checking for trouble codes is part of _ .
 - a. 1. Verifying the problem
 - b. 2. Analyzing the problem
 - c. 3. Finding the cause
 - d. 4. Repairing the problem
 - e. 5. Checking the repair

3. Technician A says that there is no voltage drop without current flow.

Technician B says that the voltage drop across a control device should always equal the applied voltage.

Who is correct?

- a. Technician A only
 - b. Technician B only
 - c. Both A and B
 - d. Neither A nor B
4. On a 12 volt automotive electrical system, parasitic current draw must be at least 300 milliamps to retain the ECM's memory.
 - a. True
 - b. False



A series of horizontal lines for writing notes, with a large, faint, diagonal watermark reading "NOTES" overlaid across the center of the page.



WE SUPPORT
VOLUNTARY TECHNICIAN
CERTIFICATION THROUGH

National Institute for
**AUTOMOTIVE
SERVICE
EXCELLENCE**

No part of this publication may be reproduced, stored electronically, or transmitted in any form or by any means without prior written approval from Kia Motors America, Inc. KMA reserves the right to make changes in the descriptions, specifications or procedures without prior notice or obligation.

Copyright © 1999 Kia Motors America, Inc. Corporate Service Training Department



ER1

Student Learning Guide

Electrical Repairs



**Automotive
Electrical Course**



S E R V I C E T R A I N I N G



Today's vehicles are using more electronics than ever before. With computerized management systems and more electronic controlled devices, wiring problems have become a major concern. Most common electrical circuit malfunctions in today's vehicles can be traced down to a problem at the connectors. Loose or corroded connectors can cause high resistance in a circuit. These conditions may require the replacement of a wire terminal or the entire connector.

Other times a wire may become pinched or chafed and cause a short circuit. When this happens it may become necessary to replace or repair the wire or complete harness.

In this module, you will become familiar with repairing wiring, terminals and connectors.

LEARNING OBJECTIVES

- Identify terms related to wiring harness repair.
- Perform a satisfactory wire repair.
- Perform a satisfactory terminal replacement.

ER1-1

MODULE DIRECTIONS

Carefully read this material. Study each illustration as you read the material. Feel free to ask questions any time something is not clear. Be sure to answer the questions in the activity and at the end of the module.

WHAT YOU WILL NEED

- Terminal repair kit
- Soldering iron with stand
- Solder
- Heat shrink gun

- Provide current to all points of the vehicle
- Bundles of wire
- Bound in tubing or taped
- Attached to each other by connectors

ER1-2

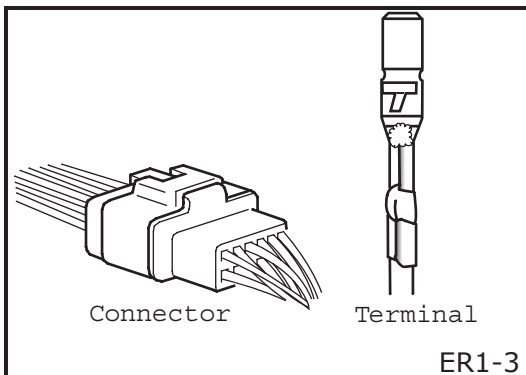

ER1-3

- Splice complete connector with terminals and wire pigtail to the harness
- Stager splices

ER1-4

HARNESSES

To provide current flow throughout the vehicle wire harnesses are used. Wire harnesses are bundles of wires that are bound together in plastic tubing or wrapped with tape. Bundling the wires together offers protection for the wires as well as organization. A vehicle will have several wire harness sections so that a section can be replaced without replacing all the wire in the vehicle. The sections are attached to each other with connectors.

CONNECTORS AND TERMINALS

Every wire in a vehicle ends up in some type of connector or terminal. A connector is usually a plastic piece that houses the wire terminal or terminals. A terminal is a device attached to the end of a wire or component to make the electrical contact point removable. Various types of connectors, terminals and junction blocks are used on Kia vehicles. The Electrical Troubleshooting Manual can be used to identify each type used in a circuit. The connector is an excellent point for conducting tests because the circuit can be opened without damage to the wires. Connectors can also be a major source of electrical problems. The connector can be improperly connected, corroded or have missing or bent terminals.

Connector Replacement

Connectors can be replaced in one of two ways:

- By splicing a complete connector with terminals and wire pigtail to the harness
- By removing all the terminals and replacing just the connector housing

If replacing a complete connector, be sure to stagger the splices so that they are not all in the same area. If replacing the empty connector, ensure that the replacement connector is identical to the original connector.

Check for:

- Damage
- Corrosion
- Bent/missing terminals
- Terminal tension

Always insert test lead probes from the wire side

ER1-5

Connector Inspection

Check for signs of damage or corrosion to the outside and inside of the connector. Check for bent or missing terminals. Check for good terminal tension. When a tester is used to check the continuity or to check the voltage, insert the tester probes from the wire harness side.

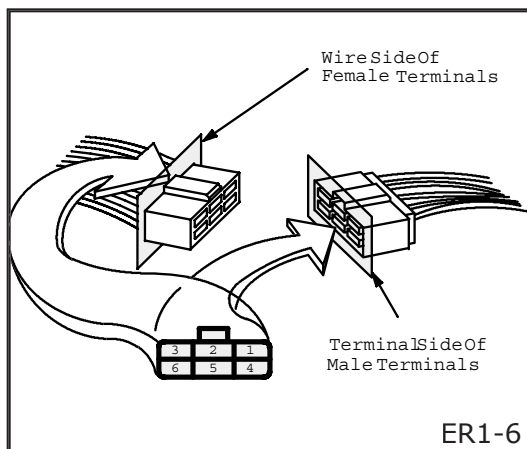

ER1-6

Connector Terminal Identification

Most male connectors will have female terminals and most female connectors will have male terminals. The cavities (and wire terminals) in each connector are numbered starting from the upper right looking at the male terminals from the terminal side or looking at the female terminals from the wire side. Both views are in the same direction so the numbers are the same. All cavities are numbered, even if they have no wire terminals in them.

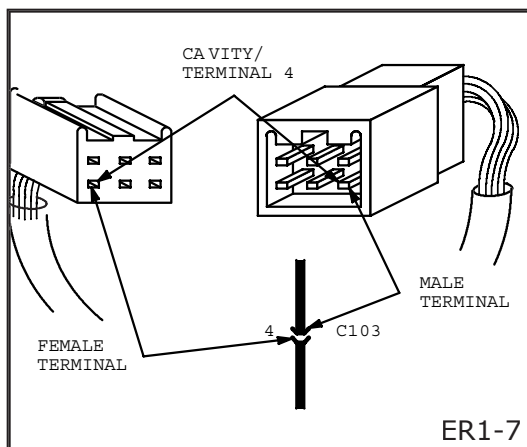

ER1-7

The connector cavity number is listed next to each terminal on the circuit schematic. The cavity/terminal shown is #4.

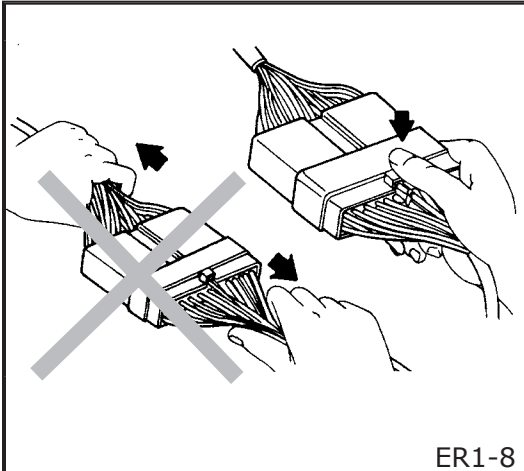

ER1-8

Disconnecting the Connector

The connector can be disconnected by pressing the lock lever. Do not pull on the wires when disconnecting the connector. Be careful to hold the connector housing itself when disconnecting it.

- Step 1. Identify the connector and terminal type
- Step 2. Remove the terminal from the connector
- Step 3. Replace the terminal
- Step 4. Install the terminal into the connector

ER1-9

Terminal Replacement

Terminal replacement is easy if done correctly. The first step is to identify the type of connector and terminal. Check for the position of the lock tab and direction of unlocking.

The second step is to remove the terminal from the connector. This is done by inserting a push-tool into the connector against the locking tab while pulling the wire, with terminal, out of the connector. Some connectors may have a secondary locking device that will need to be removed prior to removing the terminals.

The third step is to replace the terminal. Select the correct replacement terminal from the terminal repair kit. Strip about 1/4 inch of insulation from the end of the wire. Insert the stripped end of the wire into the replacement terminal. Using a crimping tool, crimp the first tab of the terminal over the bare wire. Then crimp the second tab over the insulated portion of the wire.

The fourth step is to install the terminal into the connector. Check that the locking tab is in good condition and in the correct position. Push the terminal into the connector until you hear or feel the "click". Gently pull on the wire lead to ensure that the terminal is seated correctly in the connector. If needed, install the secondary locking device.



ER1-10



ACTIVITY

Replacing a Terminal

In this activity you will remove and replace a terminal in a connector and attach a terminal to a piece of wire. Follow the steps outlined on the previous page for replacing a terminal. When finished have your instructor check your work.

WARNING

Always ensure that the negative battery cable is disconnected prior to performing wire repairs.

ER1-11

WARNING

Do not repair SRS harnesses.

ER1-12

1. Select wire type and size
2. Cut wire to required length
3. Slide heat shrink tube over wire
4. Strip ends of wires
5. Insert wires into splice joint
6. Crimp the splice joint
7. Flow solder into splice joint
8. Slide heat shrink over repair and heat

ER1-13

WIRE REPAIRS

Wire repairs are sometimes needed because of damage caused by electrical faults or by physical abuse. When a damaged wire must be replaced, make sure the same or larger size wire is used. Also, use the same color wire if possible.

Always ensure that the battery is disconnected prior to performing wire repairs.

Splicing Wires

The Kia recommended wire splice repair is to use a crimp joint and solder. To perform this type of splice follow these steps:

1. Select the correct wire type and size required.
2. Cut the wires to the necessary length.
3. Slide a piece of heat shrink tubing over the wire to be repaired. Make sure the shrink tubing will overlap the repair by about 1/2-inch on both sides of the repair.
4. Strip the ends of the wires to be joined.
5. Insert one wire into the inline solder joint. Insert the other wire into the other end of the inline solder joint.
6. Crimp the center of the inline solder joint.
7. Flow solder into both ends of the inline solder joint.
8. Slide the heat shrink tubing over the repair and heat the heat shrink tubing to seal the repair.



ACTIVITY

Splicing a Wire

In this activity you will splice two pieces of wire together with an inline solder splice joint. Follow the steps outlined on the previous page for splicing a wire. When finished have your instructor check your work.

FEEDBACK

SELF-TEST

This self-test will enable you to measure the knowledge that you have gained about Electrical Repairs. Circle the one best answer that completes the statement or answers the question.

1. The plastic piece attached to the end of a wire that houses the wire terminal or terminals is the:
 - a. Terminal
 - b. Plug
 - c. Connector
 - d. Socket

2. What should always be done prior to any wire repair?
 - a. Remove the harness from the vehicle
 - b. Clean the wires to be repaired
 - c. Replace blown fuses
 - d. Disconnect the vehicle's battery

3. When checking the continuity through a connector, the connector should be disconnected and the test lead probes should be inserted from the terminal side.
 - a. True
 - b. False

4. What is the Kia recommended method for doing a wire splice?
 - a. Twist the wires together and tape
 - b. Use an inline solder joint
 - c. Replace the harness
 - d. Install a connector at the damaged portion of the wire

5. In the connector shown below, into which cavity would terminal Number 4 be inserted?

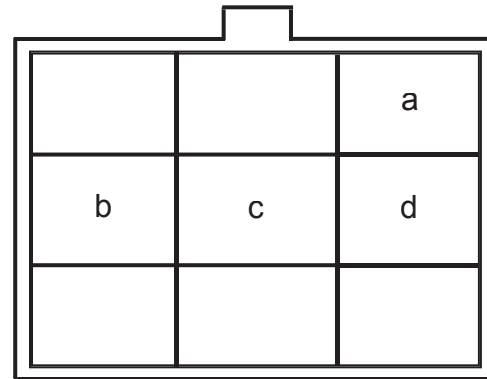



A series of horizontal lines for writing notes, with a large, faint, diagonal watermark reading "NOTES" overlaid across the center of the page.



WE SUPPORT
VOLUNTARY TECHNICIAN
CERTIFICATION THROUGH

National Institute for
**AUTOMOTIVE
SERVICE
EXCELLENCE**

No part of this publication may be reproduced, stored electronically, or transmitted in any form or by any means without prior written approval from Kia Motors America, Inc. KMA reserves the right to make changes in the descriptions, specifications or procedures without prior notice or obligation.

Copyright © 1999 Kia Motors America, Inc. Corporate Service Training Department



ES1

Student Learning Guide

Battery, Charging and Starting Systems

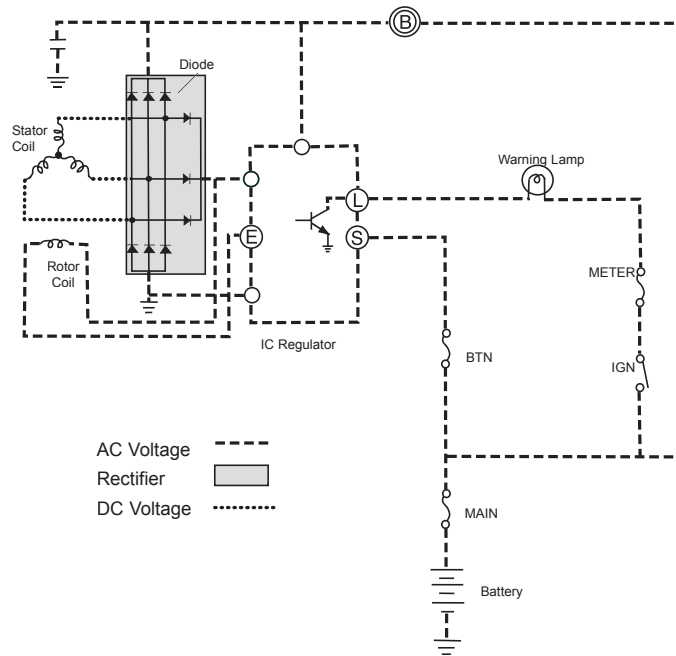

Automotive Electrical Course



SERVICE TRAINING



In this module you will examine the operation and function of the battery, starting system and charging system used on Kia vehicles. You will also become familiar with the service and test procedures of these systems. Hands on exercises will be used to reinforce the information.

LEARNING OBJECTIVES

After successfully completing this module you should be able to complete the following.

For the battery, charging system and starting system:

- Identify terms
- Identify various parts and their functions
- Perform operational tests

ES1 - 1

MODULE DIRECTIONS

Carefully follow the procedures and answer the questions in this module. Study each illustration as you read the material. Feel free to ask questions any time something is not clear.

When you have completed all of the activities, see your instructor for module sign off.

THINGS YOU WILL NEED

- Digital multimeter
- A starter
- An alternator
- 1998 or later Sephia or Sportage
- Service Manual for the vehicle
- Battery tester

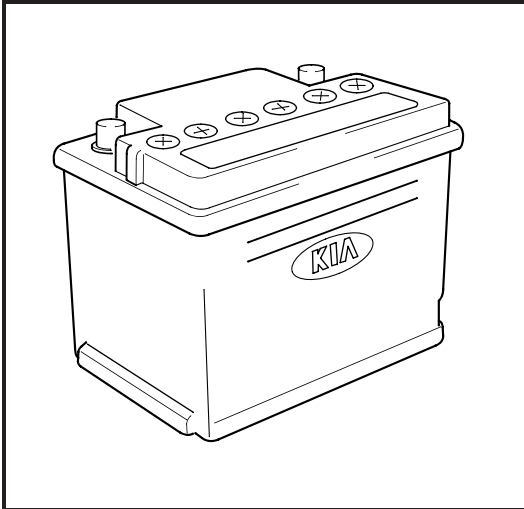

THE BATTERY

The battery converts chemical energy into electrical energy. The battery stores chemicals that will react to create electricity. There are two types of metals in the battery and when an acid is added a reaction takes place that produces an electrical voltage. The battery provides the energy for the starter system and acts as a voltage stabilizer for the electrical system. When the electrical system load exceeds the generator output, the battery can also provide extra power for a limited time.

Battery Functions

- Stores chemicals
- Chemical reaction creates electricity
- Provides energy for starter
- Voltage stabilizer for electrical system

ES1 - 2

1. When the engine is off the battery provides energy to operate the lighting and accessory systems.
2. When the engine is starting the battery provides energy to operate the starter motor and the ignition system during cranking.
3. The charging system is unable to provide for the extra energy needed to operate the electrical loads when the engine is running. The battery supplies this extra energy needed to operate the electrical loads. The battery also works as a voltage stabilizer by absorbing abnormal, transient voltages in the vehicle's electrical system.

- When engine off, provides energy for accessories
- Energy to ignition & starter motor during cranking
- Supplements energy during high load periods
- Absorbs transient voltages

ES1 - 3

Battery Type

The battery used in Kia vehicles are of the lead-acid type. The battery is a conventional, low maintenance type, 12 volt 48 amp-hour battery. There is no built-in hydrometer. The electrolyte level and specific gravity should be checked occasionally. The Sephia battery has a reserve capacity of 99 minutes and a cold cranking amperage rating of 460 amps. The Sportage battery has a reserve capacity of 99 minutes and a cold cranking amperage rating of 470 amps.

- Conventional
- Lead acid
- 12 volt, 48 amp-hour
- Low maintenance

ES1 - 4



Capacity Ratings

Capacity is the amount of current a fully charged battery can delivery for a specified time and is expressed in ampere-hours. The battery's capacity is determined by the size and number of plates, the number of cells and the strength and volume of the electrolyte. The battery's capacity is rated in three ways:

COLD CRANKING AMPERES (CCA)

A fully charged battery's discharge load for 30 seconds at 0°F while maintaining 7.2 volts

Sephia 93-97 535
CCA

Sephia 98-99 460
CCA

Sportage 95-9/98 470 CCA

Sportage 9/98-99 525 CCA

ES1 - 6

- **COLD-CRANKING AMPERES (CCA)**

The battery's primary function is to crank the engine during starting. To do this the battery must provide a large amount of current in a short period of time. Certain factors, such as engine size and temperature will determine the CCA rating of a battery. The CCA rating is *the discharge load a fully charged battery at 0°F can deliver for 30 seconds while maintaining a voltage of 7.2 volts*. The CCA rating of Kia batteries varies from 460 amps to 535 amps.

RESERVE CAPACITY (RC)

- Time in minutes that a fully charged battery can be discharged:

at 25 amps
at 80°F
while maintaining 10.5 volts

- Kia batteries ratings = 99 minutes

ES1 - 7

- **RESERVE CAPACITY (RC)**

If the vehicle's charging system fails the battery will provide power for the ignition, lights and accessories for a certain amount of time. The amount of time that the battery will provide is called the reserve capacity (RC). The RC rating is *the length of time in minutes that a fully charged battery at 80°F can be discharged at 25 amps while maintaining a voltage of at least 10.5 volts*. The RC rating of Kia batteries is 99 minutes.

AMP-HOURS

Current provided for 20 hours at 80°F while maintaining 10.5 volts

Example: 2.4A x 20 hrs. = 48 AH

- Kia batteries ratings = 48 amp-hours

ES1 - 8

- **AMP-HOURS (AH)**

The battery must be able to maintain adequate lasting power under light-load conditions. Also called the 20-hour discharge rating. The AH rating is *the current in amperes the battery can provide for 20 hours at 80°F while maintaining a voltage of at least 10.5 volts*. The AH rating of the Kia batteries is 48 amp-hours.



- Lead dioxide (+) & sponge lead (-)
- Electrolyte

ES1 - 9

- Discharge - Current flows from - to + until both - & + plates have a balanced number of electrons
- Recharge - Voltage is applied in a reverse direction until plates return to their original condition
- Discharging/Recharging can occur many times

ES1 - 10

- Cracks in case
- Tight terminals
- Cracked or broken cables
- Corroded terminals
- Dirt or acid on case top
- Loose battery hold down
- Adequate electrolyte level

ES1 - 11

How a Battery Works

A lead-acid battery has two different metals, lead dioxide and sponge lead, in a container of electrolyte (water and acid). The lead dioxide has a positive electrical charge and the sponge lead has a negative electrical charge. The two different metals and the acid solution create a chemical reaction which produces an electrical voltage.

A current will flow when a conductor and a load are connected between the two metals. If the current is allowed to flow the battery will discharge until the metals become alike and the acid is used up. If a current is applied to the battery in the opposite direction, it will charge the battery until the materials are returned to their original condition. The partial discharging and recharging of the battery can occur many times.

Battery Inspection

- Check for cracks in the case and loose or broken terminals. Replace battery.
- Check for cracked or broken cables or connections. Replace as needed.
- Check for corrosion on terminals and dirt or acid on the case top. Clean with a mixture of water and baking soda. Use a wire brush on terminals.
- Check the rubber protector on the positive terminal for proper coverage.
- Check for loose battery hold down and loose cable connections. Tighten as needed.
- Check the electrolyte level. It should be between the UPPER LEVEL and LOWER LEVEL. If not, add **distilled** water to bring level up to UPPER LEVEL. Do not overfill.

- State of charge (chemical condition)
 - Hydrometer (specific gravity)
 - Open circuit voltage test (checks available battery voltage with no load)
- Ability to deliver current (adequate cranking power)
 - Load test (checks battery's ability to provide current under a load)

ES1 - 12

Battery Testing

Batteries can be tested to determine **state of charge** and **ability to deliver current**. The state of charge test checks the battery's chemical condition while the ability to deliver current test measures the battery's ability to deliver adequate cranking power.

STATE OF CHARGE

State of charge can be measured by two methods: with a hydrometer or with an open-circuit voltage test.

Hydrometer

As a battery discharges, the acid becomes weaker as some of it combines with the plate material. The hydrometer test is used to check the specific gravity, or exact weight, of the electrolyte. By weight the electrolyte in a fully charged battery is about 36% acid and 64% water. Water's specific gravity is 1.000 and sulfuric acid's specific gravity is 1.835. When combined the electrolyte mixture has a specific gravity of 1.270.

By measuring the specific gravity of the electrolyte, you can tell if the battery is fully charged, needs charging or must be replaced.

Test Procedure:

1. Remove the caps from the battery cells.
2. Squeeze the hydrometer bulb and insert the pickup tube into the cell nearest to the positive terminal.
3. Slowly release the bulb allowing the electrolyte to flow into the hydrometer only enough to cause the float to rise.
4. Read the specific gravity and temperature of the electrolyte.
5. Record your readings and repeat the procedure for the remaining cells.

Recharge the battery if the specific gravity is below the standard of **1.280 at 77°F**. Replace the battery if the specific gravity varies more than 0.05 between any two cells.

Note: Kia replacement batteries may have an indicator eye built into the battery. This is a reference only; a more thorough visual inspection and state of charge test should be used.

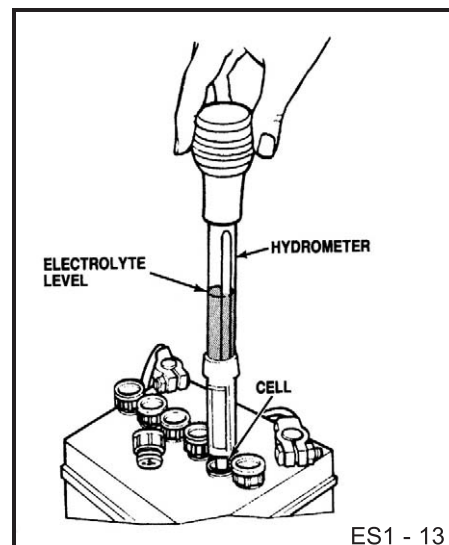

Indicator Eye

- Green - Good
- Black - Low electrolyte level or low charge

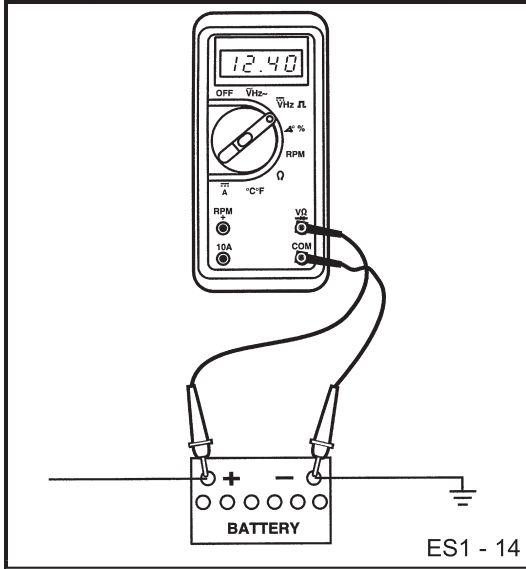

Open-Circuit Voltage Test

An open-circuit voltage test simply checks available battery voltage with no load. A digital voltmeter is used to check the battery's open-circuited voltage. The voltage reading indicates the battery's state of charge.

If the battery has just been charged, turn the headlamps on for one minute to remove any surface charge. Turn the headlamps off and connect a voltmeter across the battery terminals. A fully charged battery will have a voltage reading of at least 12.6 volts. A dead battery will have a voltage reading of less than 12.0 volts.

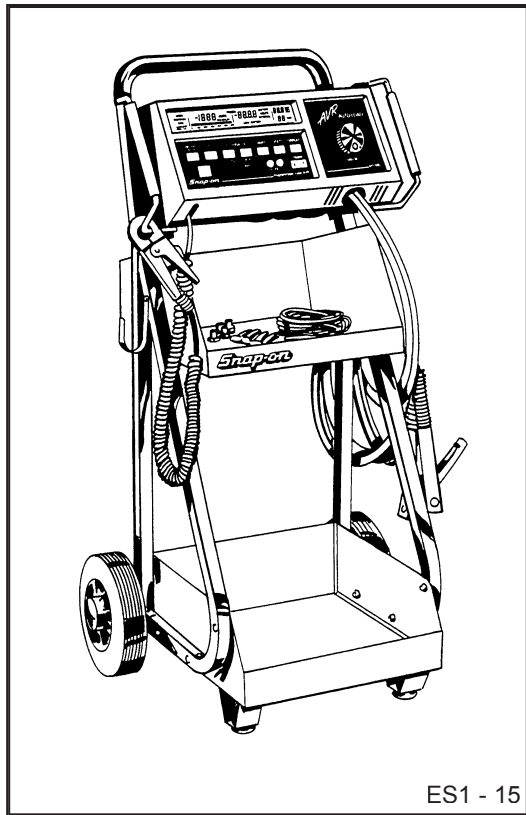

CAPACITY OR LOAD TEST

The capacity or load test is used to check the battery's ability to deliver adequate cranking power. This test simulates a load on the battery such as that provided by the starter motor. A battery load tester, such as the Snap-On MT1590 or the Sun VAT-40 is needed. Follow the manufacturer's recommended procedures for the tester that you are using.

Before load testing a battery be sure to visually inspect the battery for defects and make sure the battery meets or exceeds the minimum state of charge requirement.

Using the load tester, slowly apply a load to the battery until the ammeter reads 3 times the amp-hour (AH) rating or one-half the cold cranking ampere (CCA) rating. Maintain the load for no more than 15 seconds.

If the voltmeter reading is above 10.0 volts the battery is good. If the reading is 9.6 to 9.9 volts, the battery is serviceable, but requires charging and retesting. If the voltage reading is below 9.6 volts, the battery is either discharged or defective.



Fast charging

- High rate of current for short time
Max. current = 20 amps

Slow charging (recommended)

- Complete recharge
Current = 1/10 of battery's AH rating

ES1 - 16

Battery Charging

To recharge a battery, current must be applied to the battery in the opposite direction of the discharge flow. This restores the imbalance of electrons in the battery. There are two basic methods of charging the battery: **fast charging** and **slow charging**.

Fast charging is done by applying a high rate of current to the battery for a short period of time. The fast charge method should not be used on a completely discharged battery, to prevent damage to the battery. The maximum recommended charging current is 20 amperes.

The **slow charge** method will completely recharge the battery by charging with a lower current for a longer period of time. The maximum charging current should be less than 1/10th of the battery capacity. For instance, a 40 AH battery should be slow charged at 4 amps or less.

CHARGE RATE CHART*

RC Rating	AH Rating	5A	10A	20A	30A	40A
less than 75	less than 48	10 hrs	5 hrs	2.5 hrs	2 hrs	
75 - 115	48 - 75	15 hrs	7.5 hrs	3.25 hrs	2.5 hrs	2 hrs
115 - 160	75 - 100	20 hrs	10 hrs	5 hrs	3 hrs	2.5 hrs
160 - 245	100 - 150	30 hrs	15 hrs	7.5 hrs	5 hrs	3.5 hrs

* For fully discharged batteries

ES1 - 17

Kia Specifications

CAUTION

Remember that a battery may lose its charge while the vehicle is sitting on the lot waiting for sale (lot rot). To avoid an embarrassing moment with a customer or the replacement of a battery, be sure to start vehicle inventory often enough to maintain a full charge on the battery.

ES1 - 18

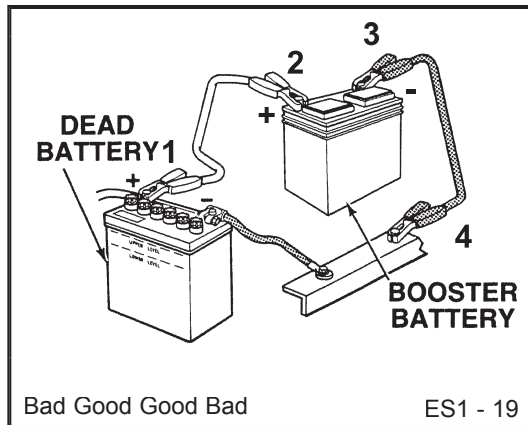

Jump Starting

Occasionally it may be necessary to jump-start a vehicle that has a discharged battery with a vehicle with a good battery. It is a simple process, but done incorrectly can result in personal injury or damage to either vehicle. Using the following procedures can reduce the risks of personal injury and damage to the vehicle.

1. Position the vehicle with the good battery close enough to the vehicle with the discharged battery so that the jumper cables can be connected to each battery. **Do not allow the vehicles to touch each other.**
2. All accessories should be turned off in both vehicles. Turn the ignition off in both vehicles prior to connecting the jumper cables.
3. Connect one end of the positive jumper cable to the positive terminal of the discharged battery. Then connect the other end of the positive jumper cable to the positive terminal of the booster battery.
4. Connect one end of the negative jumper cable to the negative terminal of the booster battery. Then connect the other end of the negative jumper cable to the engine ground of the vehicle with the discharged battery.
5. Start the engine of the vehicle with the good battery and allow it to idle.
6. Start the vehicle with the discharged battery.
7. Remove the jumper cables in the reverse order that they were connected. Negative first, then positive.

Charging System

- Ignition switch
- Generator
- Voltage Regulator
- Drive Belt
- Battery
- Warning Lamp

ES1 - 21

THE CHARGING SYSTEM

Components

The charging system consists of the ignition switch, generator, voltage regulator, drive belt, battery and warning lamp.

Operation

When the ignition switch is turned to ON or START, battery voltage is applied to the charge indicator and terminals B and S of the generator. After the engine has started and

is running, the drive belt transfers a portion of the mechanical energy of the engine to the generator to produce an alternating current. The alternating current flows through a series of rectifier diodes within the generator and is converted to direct current. The direct current and voltage keeps the battery fully charged and provides power to operate the vehicle's electrical systems. The amount of direct current and voltage the generator outputs is controlled by the voltage regulator. On Kia vehicles, the voltage regulator is built into the generator. If the voltage regulator senses that the output of the generator is not sufficient for charging the battery, it will ground terminal L of the generator and the charge indicator will illuminate.

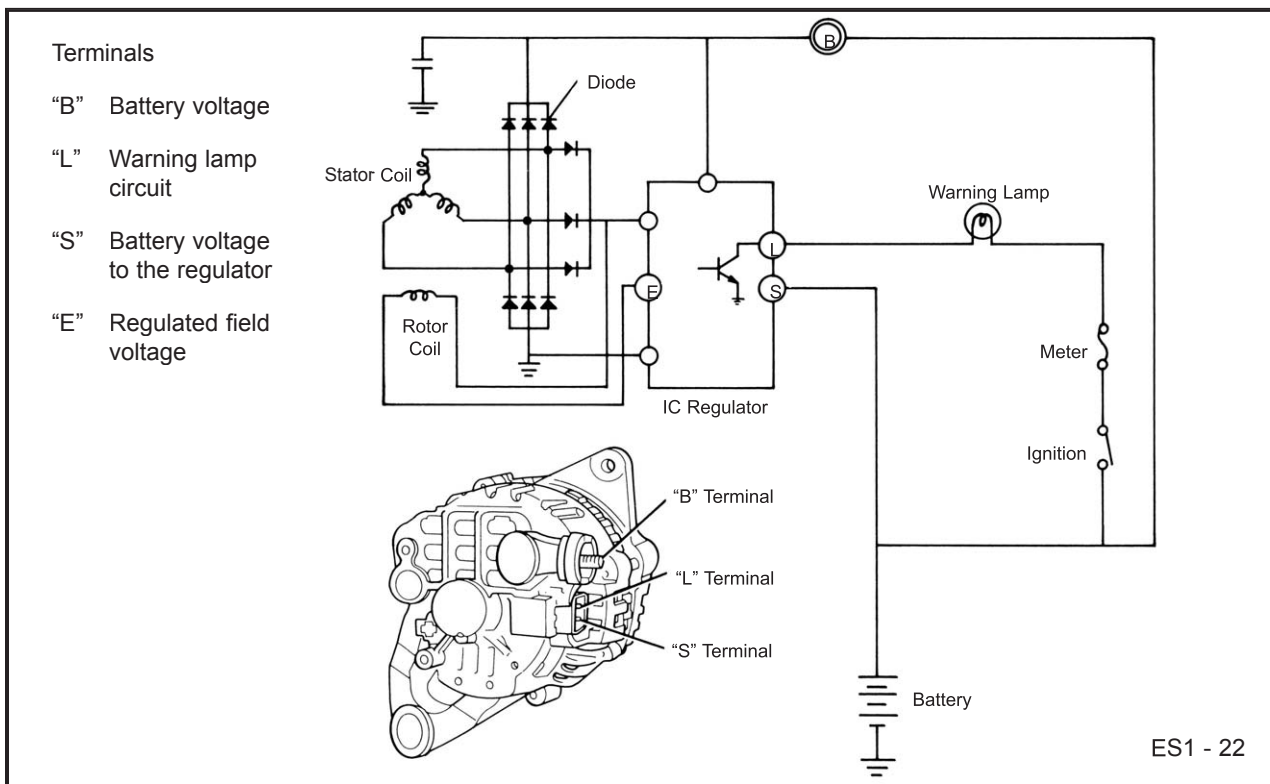

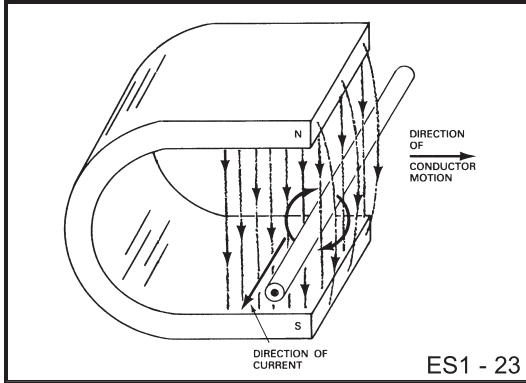

Generator Operation

The generator works on the principles of electromagnetic induction. This is when a magnetic field crosses a conductor and voltage is created in the conductor. It does not matter whether the magnetic field crosses the conductor or whether the conductor moves across the magnetic field. All that is required is some form of movement. In the generator, the magnetic field moves and creates voltage in coils of wires.

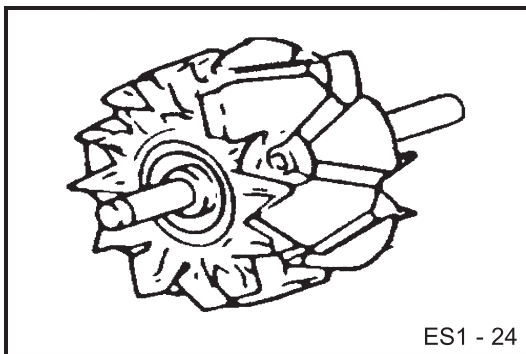

The rotor is the rotating part of the generator. It is made up of two iron pole pieces mounted on a rotor shaft. Between the two pole pieces is a core with many turns of wire wound over it. When current flows through the core winding, it becomes a strong electromagnet. The fingers of the pole pieces are in the magnetic field of the core. Alternate fingers become North and South magnetic poles. The wires leading to and from the core winding are connected to copper slip rings on one end of the rotor shaft. The slip rings are electrically insulated from the rotor shaft. Carbon brushes ride on the slip rings and provide a path for the current that energizes the core's electromagnet.

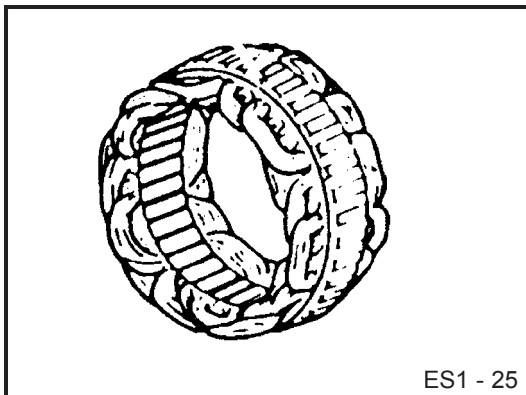

The stator is the generator component in which electricity is produced. The stator does not move; instead, the rotor turns inside the stator. Like the rotor, the stator has many turns of wire wound around it. In a typical stator these wires are organized into three separate windings.

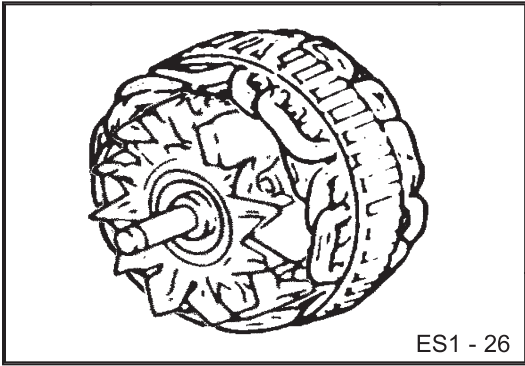

ES1 - 26

In operation, the rotor turns inside the stator. As the rotor turns, it induces an alternating current or AC in the windings of the stator.

Automotive electrical systems are not designed to use alternating current. The generator uses a device known as a rectifier to convert AC to DC. A rectifier is made up of three sets of diodes. Diodes are semiconductors that allow current to pass in one direction only. You can think of rectifier diodes as switches, operated by voltage polarity. They turn on and conduct current when you apply one polarity; they turn off and block current when you apply the opposite polarity. This is the process that converts AC to DC.

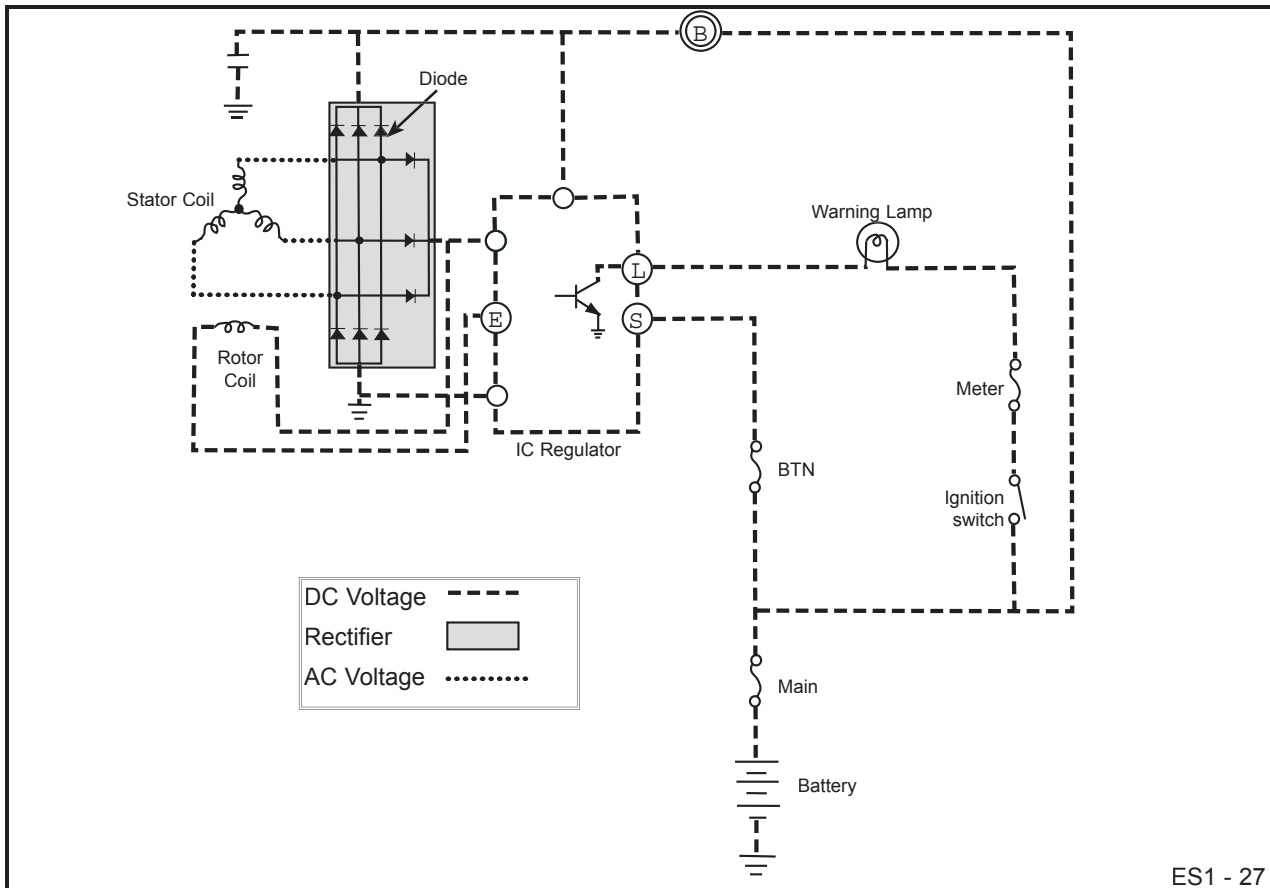

ES1 - 27

- Needed because an unregulated voltage will follow engine speed
- Controls field current of rotor; increases or decreases depending on needs of load

ES1 - 28

Voltage Regulator

Under most driving conditions the load on the vehicle's electrical system is somewhat constant. If the head lamps are on, no matter what the engine speed, the load is the same. An unregulated generator will have a variable output as the engine speed changes. To keep the head lamps at the same brightness, at

both idle and high speed, a voltage regulator is needed. On Kia vehicles, the voltage regulator is located inside the generator.

The voltage regulator controls output by varying the excitation current to the rotor's field winding. This excitation current, also known as field current, produces the rotor's magnetic field. The larger the current, the stronger the field. In operation, as the turning speed of the generator rotor increases, the regulator decreases the excitation current just enough to keep the output the same. In the same way, as rotor speed decreases, the regulator increases the excitation current just enough to keep the output the same.

During normal operation, the excitation current is supplied to the rotor field winding from the stator windings through the diodes. However, when the generator first begins to turn, the excitation current is briefly supplied through the charge warning lamp.

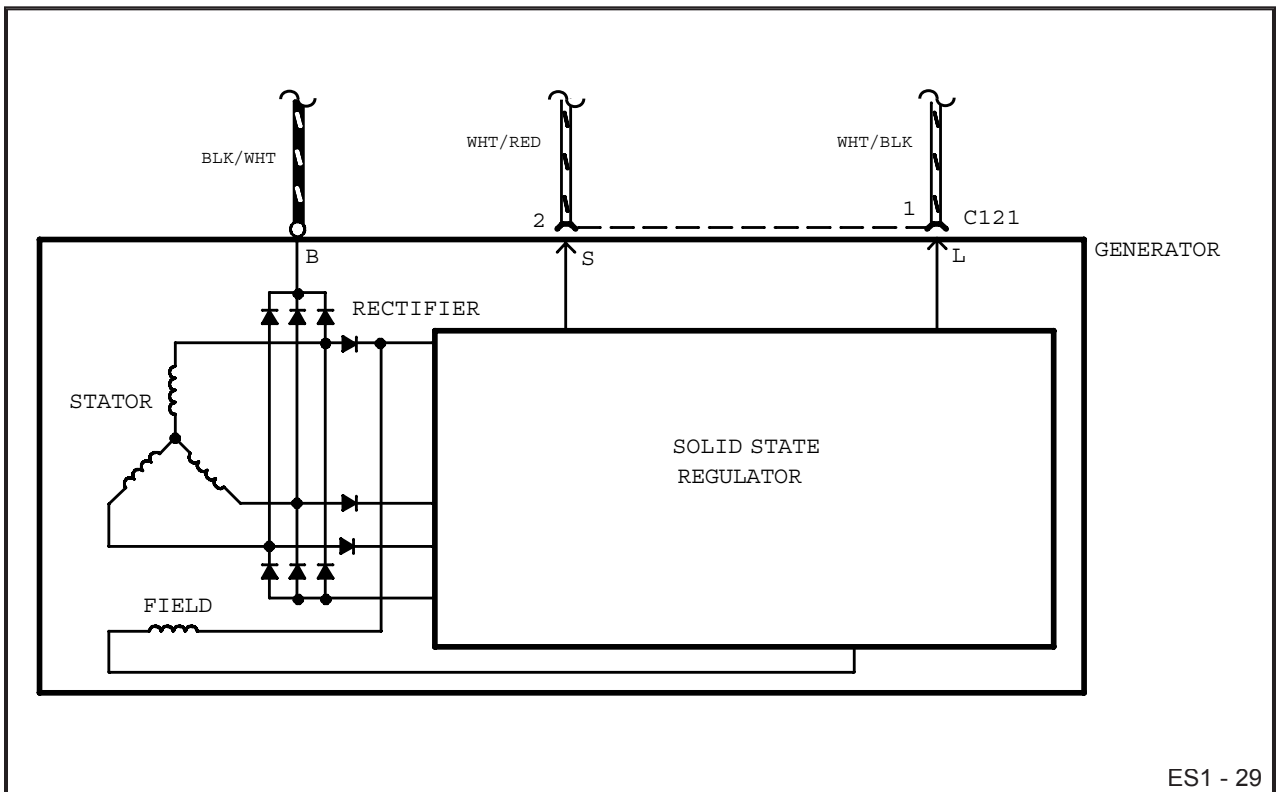

ES1 - 29

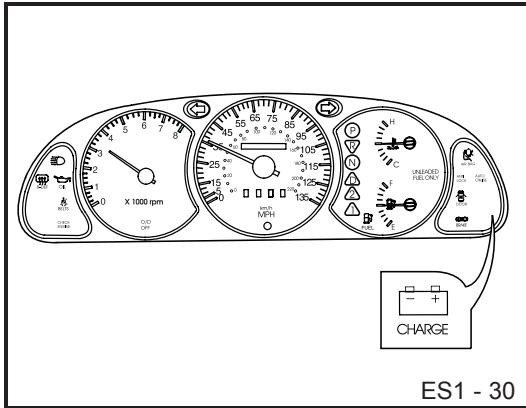

Charging System Warning Lamp

The Charging System Warning Lamp should come on when the ignition switch is turned ON. Current flows from the ignition switch to the warning lamp. The ground is completed through the generator "L" terminal and control circuit to the generator case that is grounded to the engine.

If the warning lamp does not come on when the ignition is turned to ON, check for an open indicator bulb, blown fuse or an open circuit between the "L" terminal and the ignition switch.

When the ignition switch is turned to START and the engine starts the light will go out. The generator control circuit opens the warning lamp ground and applies current to the "L" terminal. The diode in the warning lamp assembly protects the electrical system from unwanted current flow in this mode.

If there should be a generator or control circuit malfunction, the "L" terminal will switch back to ground and turn the warning lamp on.

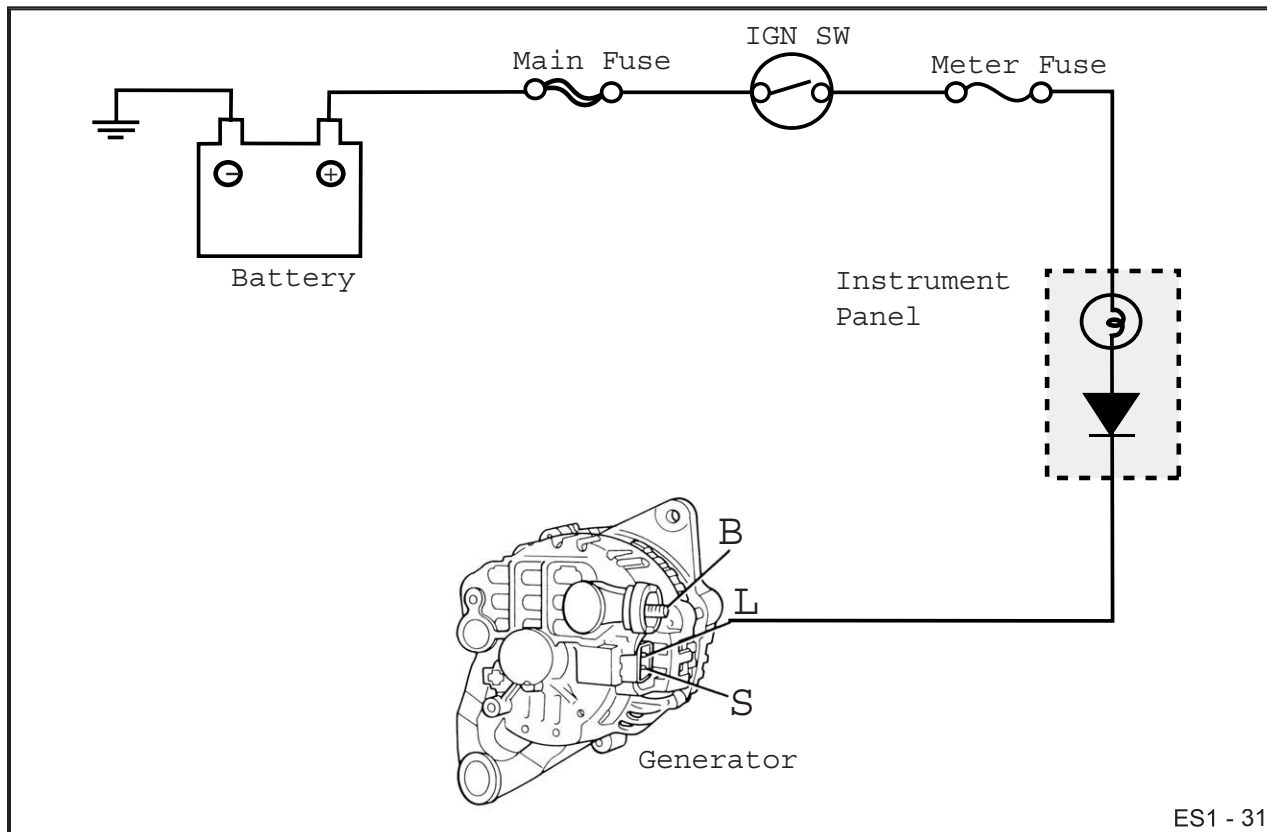



Prior to diagnosis, check for:

- Fully charged battery
- Tight connections
- Properly adjusted drive belt

Common problem conditions:

- No charge
- Low charge
- Overcharge

ES1 - 32

Charging System Diagnosis

Before attempting to troubleshoot the charging system make sure that the battery is fully charged and will hold a charge. Then check that all connections at the battery, generator, Engine Compartment Fuse/Relay Box, and also throughout the charging circuit are correct and making good electrical contact. Once you have determined that the charging system is at fault the problem can be further diagnosed by checking for the charge condition. Most charging system problems come under one of the following conditions: no charge, low charge or overcharge.

NO CHARGE

If the charge warning lamp remains brightly lit with the engine running, the generator is not charging at all. A broken or extremely loose drive belt could cause a no-charging condition. If the belt is okay, the problem is in the charging system. Remove the connector containing the "S" and "L" wires. If the warning lamp goes off, check generator output. If the warning lamp stays on, check the "L" terminal wire for a short to ground.

Indication = Brightly lit warning lamp with engine running

Probable cause

- Loose drive belt
- Defective generator
- Wiring problem

Action

- Remove "S/L" connector
 - Note warning lamp, if:
 - OFF - Check generator output
 - ON - Check "L" terminal wire for short to ground

ES1 - 33



LOW CHARGE

If the charge warning lamp glows slightly, it means that the generator is charging, but its output is low. The drive belt could be loose. However, if the drive belt is tensioned correctly and is in good condition the problem is in the charging system. Check the battery and its connections. If no problem is found, check the generator's output current.

Indication = <u>Warning lamp glows slightly</u>	
Probable cause	Action
<ul style="list-style-type: none"> • Loose drive belt • Low battery charge • Loose/dirty connections • Low generator output 	<ul style="list-style-type: none"> • Adjust/replace drive belt • Check battery state of charge • Check/clean connections • Check generator output
ES1 - 34	

OVERCHARGE

Frequent burning out of fuses or lights or the repeated addition of water to the battery may be an indication of a generator that is overcharging the system. Make sure all the connections on the generator are clean, tight and correct. If everything is okay, the charging system is at fault.

Remove the connector containing the "S" and "L" wires from the generator. Turn the ignition switch to ON but do not start the engine. Connect a voltmeter between the "S" terminal and ground. If no voltage is present, the circuit between the terminal and the battery is either grounded or open. Repair as required.

Re-install the connector. Run the engine at a moderate speed with all accessories off and measure the battery voltage. If the voltage is above 16.0 volts replace the generator.

Indication = <u>Frequent burning out of fuses or lights</u> <u>Rapid depletion of electrolyte solution</u>	
Probable cause	Action
<ul style="list-style-type: none"> • Wiring/connector problem • Dirt or corrosion on the battery • Defective battery • Defective generator 	<ul style="list-style-type: none"> • Check for shorted/open wires & connector problems • Clean battery & terminals • Check battery state of charge • Check generator output
ES1 - 35	



Charging System Troubleshooting

Problem	Possible Cause	Action
Warning lamp does not light, with ignition ON and engine off.	<ol style="list-style-type: none">1. Blown fuse2. Lamp burned out3. Open circuit between the "L" terminal and the ignition switch	<ol style="list-style-type: none">1. Check METER fuse; replace if needed2. Check lamp; replace if needed3. Check for open in circuit; repair as needed
Warning lamp does not go out with engine running; no charge, low charge or overcharge.	<ol style="list-style-type: none">1. Loose or worn drive belt2. Defective battery or battery connections3. Defective wiring4. Defective generator	<ol style="list-style-type: none">1. Check drive belt; adjust or replace if needed2. Check battery and connections; charge or replace as needed3. Check voltage drop on circuit4. Check charging system output
Noise	<ol style="list-style-type: none">1. Loose or worn drive belt2. Worn generator bearings3. Defective diode in the generator	<ol style="list-style-type: none">1. Check drive belt; adjust or replace as needed2. Replace generator3. Replace generator

THE STARTING SYSTEM

One of the most important functions of the vehicle's electrical system is starting the engine. This is accomplished by the starting system which consists of two major components, the starter motor and the battery. Other related components that make up the starting system are the ignition switch and the automatic transmission range switch or starter clutch pedal position switch.

The starter motor converts electricity from the battery into rotational movement to turn the flywheel connected to the engine's crankshaft. The starter must crank the engine fast enough and for a sufficient length of time until the Engine Control Module has ensured the proper fuel and ignition are provided in order to keep the engine running.

Once the engine is running the starting system's job is done and is no longer needed until the next time the engine needs to be started.

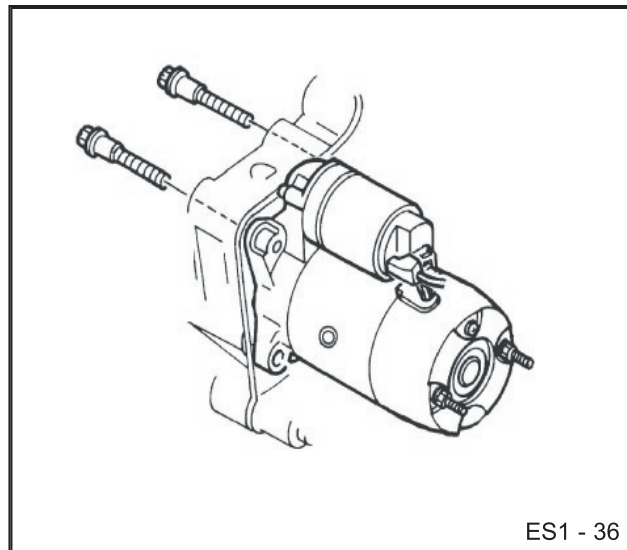

ES1 - 36

- Direct drive (manual)
- Gear reduction (automatic)

ES1 - 37

Starter Motor Types

Two different types of starter motors are used on Kia vehicles, a **direct drive** starter motor or a **gear reduction** starter motor. The conventional starter motor is used on Kia models with manual transmission/transaxle. The gear reduction starter motor is designed to reduce the speed and increase the torque required to start vehicles with automatic transmission/transaxles.

The two starter motors are different mechanically but electrically they operate identically. Both starters consist of a motor, a solenoid, a drive pinion and a housing.

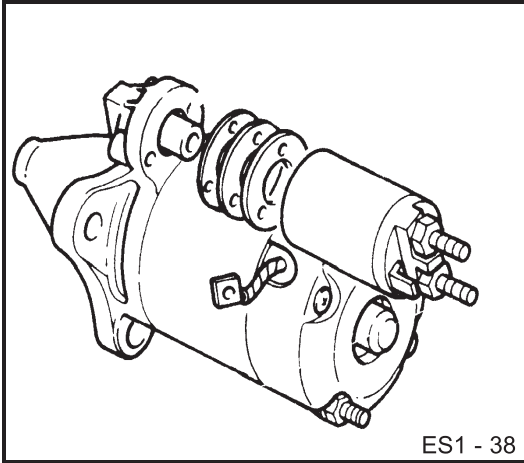

The Starter Motor Assembly

The starter motor is an assembly that includes a standard DC motor and a solenoid. The motor does the actual work of changing the electrical energy into mechanical energy. The solenoid is an electromagnetic switch that performs two functions. It actuates a lever that slides the pinion drive gear forward to engage with the flywheel. It also serves as a heavy duty relay for current to flow to the starter motor.

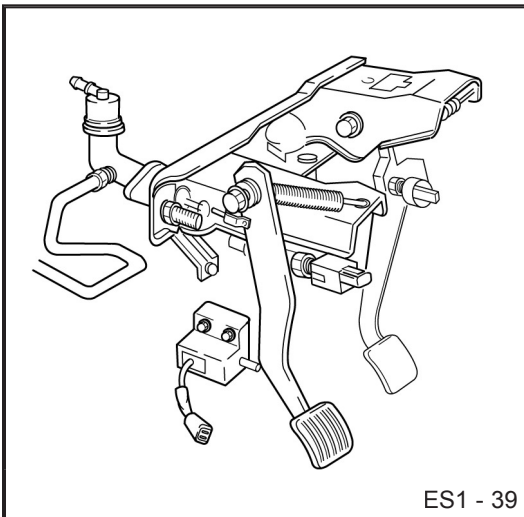

The Starter Clutch Pedal Position Switch (Manual Transmission/Transaxle Vehicles)

The clutch pedal position (CPP) switch is a safety switch which closes the circuit between the starter and the ignition switch when the clutch pedal is depressed.

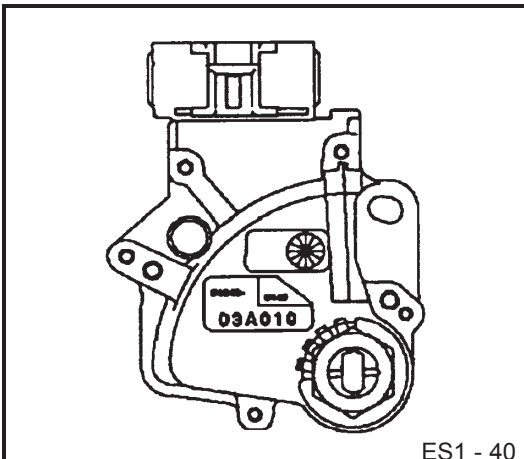

The Transmission/Transaxle Range Switch (Automatic Transmission/Transaxle Vehicles)

The transmission/transaxle range switch performs the same function as the clutch pedal position switch. When the transmission/transaxle is in NEUTRAL or PARK, the circuit to the starter solenoid is closed. If the transmission/transaxle is in any other position the circuit is open and the starter will not operate.



This page is intentionally blank.



Starting System Operation

IGNITION IN OFF POSITION

- Battery voltage is applied at all times from the positive battery terminal to the ignition switch and the normally open starter solenoid contacts.

IGNITION IN START POSITION

- Current flows through the STARTER fuse (Sephia Only) to the transmission/transaxle range switch (Automatic) or the starter clutch pedal position switch (Manual).
- If the range switch is in either PARK or NEUTRAL or the clutch pedal position switch is closed, the current will flow through the starter solenoid hold-in and pull-in coils.
- The starter solenoid coils energize, which close the starter solenoid contacts and the battery voltage is applied to the starter motor. At the same moment, the solenoid plunger pulls the drive lever to mesh the pinion drive gear with the flywheel. The starter motor engages to crank the engine.

IGNITION IN ON POSITION

- Current no longer flows to the starter solenoid.
- The magnetic fields in the coils diminish allowing the starter solenoid contacts to open.
- Current to the motor is cut off and the solenoid plunger is pushed back by spring pressure that causes the pinion drive gear to disengage from the flywheel.

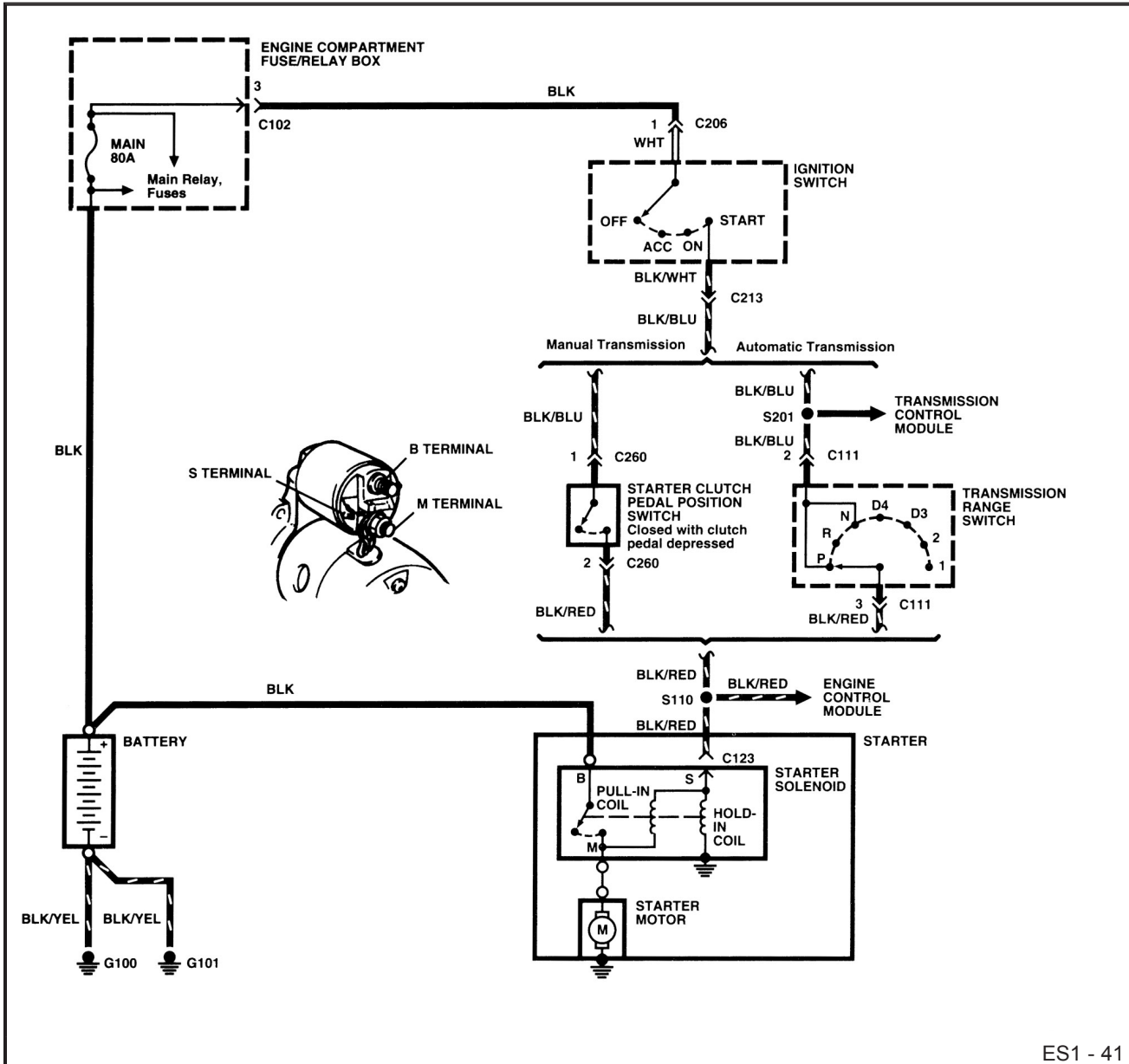

ES1 - 41



TROUBLESHOOTING

Symptom	Possible Cause	Action
Engine will not crank, starter motor does not operate	<ul style="list-style-type: none">• Dead battery• Blown STARTER fuse (Sephia Only)• Loose connections• Faulty ignition switch• Faulty CPP switch or TR switch• Open circuit in harness• Faulty starter solenoid• Faulty starter motor• Mechanical problem in engine	<ul style="list-style-type: none">• Charge or replace battery• Replace fuse• Check connections at battery, starter and harness• Replace ignition switch• Replace CPP or TR switch• Check harness• Replace starter solenoid• Replace starter motor• Check engine
Engine will not crank, but starter spins	<ul style="list-style-type: none">• Starter drive pinion gear not engaging	<ul style="list-style-type: none">• Check for starter drive pinion gear movement. Replace starter if needed• Check for damaged teeth on flywheel and pinion gear. Replace as needed
Cranks slowly	<ul style="list-style-type: none">• Weak battery• Loose or corroded connections• Faulty starter motor• Mechanical problems with engine or starter	<ul style="list-style-type: none">• Check battery and charge as needed• Clean and tighten connections• Test starter• Check engine and starter, repair or replace as needed
Starter keeps running	<ul style="list-style-type: none">• Damaged pinion or ring gear• Faulty plunger in solenoid• Faulty ignition switch• Short to battery in starter circuit	<ul style="list-style-type: none">• Check gears for wear or damage• Test starter solenoid• Check ignition switch• Check harness



FEEDBACK

This self-test will enable you to measure the knowledge that you have gained about Kia Electrical Systems. Circle the one best answer that completes the statement or answers the question.

1. A battery's reserve capacity is measured in: ____
 - a. amperes
 - b. watts
 - c. amp-hours
 - d. minutes
2. When doing an Open-Circuit Voltage Test on a fully charged battery, an acceptable voltage reading would be: ____
 - a. 9.6 volts
 - b. 11.5 volts
 - c. 12.6 volts
 - d. 15.3 volts
3. To get the best charge you should fast charge a completely discharged battery.
 - a. True
 - b. False
4. The generator works on the principles of: ____ .
 - a. mechanical induction
 - b. electromagnetic induction
 - c. thermodynamic induction
 - d. semiconductors
5. In which of the following generator components is the electrical current produced?
 - a. stator
 - b. rotor
 - c. rectifier
 - d. regulator
6. What is used to change the AC voltage, that the generator produces, to DC voltage so that the vehicle can use it.
 - a. voltage regulator
 - b. relay
 - c. stator and rotor
 - d. rectifier
7. Which of the following is a probable cause for a low charge on a battery?
 - a. loose drive belt
 - b. corroded battery connections
 - c. defective wiring
 - d. all of the above
8. Which of the following is not a function of the starter solenoid?
 - a. Serves as a heavy duty relay for current to flow to the starter motor
 - b. Sends a signal to the ECM when the starter is turning
 - c. Actuates the lever that slides the pinion drive gear forward
 - d. Houses the pull-in coil and hold-in coil
9. What causes the solenoid plunger to return to its normal position when voltage is stopped to the starter motor?
 - a. magnetic force
 - b. gravity
 - c. spring pressure
 - d. centrifugal force
10. A mechanical problem within the engine could cause the starter to continue to operate after the engine has already started.
 - a. True
 - b. False



WE SUPPORT
VOLUNTARY TECHNICIAN
CERTIFICATION THROUGH

National Institute for
**AUTOMOTIVE
SERVICE
EXCELLENCE**

No part of this publication may be reproduced, stored electronically, or transmitted in any form or by any means without prior written approval from Kia Motors America, Inc. KMA reserves the right to make changes in the descriptions, specifications or procedures without prior notice or obligation.

Copyright © 1999 Kia Motors America, Inc. Corporate Service Training Department



Student Learning Guide

Battery, Charging
and Starting
Systems
APPLICATIONS

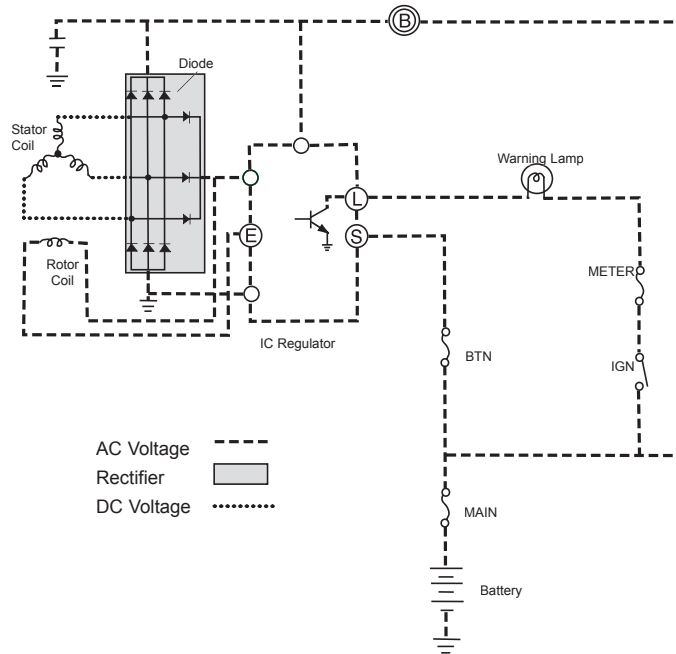

Automotive
Electrical Course





After completing the exercises in this module you will be able to diagnose and test the battery, charging and starting systems.

Knowing how to properly use these diagnostic procedures will enable you to diagnose and repair electrical system problems faster and more effectively.

LEARNING OBJECTIVES

- Complete battery inspection including: open-circuit voltage and capacity tests
- Charging system voltage check
- Charging system current output
- Starter draw test
- Bench test & inspection of generator
- Bench inspection of starter

MODULE DIRECTIONS

Carefully follow the procedures and answer the questions in this module. Study each illustration as you read the material. Feel free to ask questions any time something is not clear.

When you have completed all the activities, see your instructor for module sign off.

WHAT YOU WILL NEED

- 1998 or later Sephia or Sportage
- Service Manual for the vehicle
- Digital Multimeter with accessories
- Hydrometer
- Snap-On MT-1590 Tester



ACTIVITY

Battery Testing

In this exercise you will be assigned to a vehicle and will do the following checks.

- Battery visual inspection
- Specific Gravity Test
- Open Circuit Voltage Test
- Capacity or Load Test

VISUAL INSPECTION

Check	Condition	Recommendation
1. Case	_____	_____
2. Terminals	_____	_____
3. Cables	_____	_____
4. Connectors	_____	_____
5. Hold-Down	_____	_____
6. Drive Belt	_____	_____
7. Electrolyte	_____	_____
8. Plates	_____	_____



Instructor
Demo

HYDROMETER TEST

Cell	Specific Gravity	Temperature	Adjusted S.G.	% Charge
1	_____	_____	_____	_____
2	_____	_____	_____	_____
3	_____	_____	_____	_____
4	_____	_____	_____	_____
5	_____	_____	_____	_____
6	_____	_____	_____	_____

BATTERY CONDITION: ___ Good
 ___ Needs Charge
 ___ Bad
 ___ Requires Further Testing



ACTIVITY

OPEN-CIRCUIT VOLTAGE TEST:

1. Set voltmeter to read DC volts.
2. Connect positive lead of voltmeter to positive terminal of battery.
3. Connect negative lead of voltmeter to negative terminal of battery.
4. Record reading. _____ volts
5. Is the voltage reading at least 12.6 volts? ____ Yes ____ No
6. Is the voltage reading less than 12.0 volts? ____ Yes ____ No

HEAVY-LOAD TEST

1. Visually inspect battery and ensure that battery meets or exceeds the minimum state of charge requirement.
2. Ensure that the engine and all accessories are OFF.
3. Connect the positive (red) clamp of the battery tester to the positive (+) battery post.
4. Connect the negative (black) clamp of the battery tester to the negative (-) battery post.
5. Determine the battery load test specification. (1/2 of battery's CCA or 3 times the battery's amp-hour rating). What is the battery's load test specification? _____
6. Set the load on the battery tester.
7. Set the timer on the battery tester for 15 seconds.
8. Press the LOAD TEST start button.
9. The load will release and the display will freeze when the timer reaches 0. What was the voltage reading at the end of the 15 seconds? _____
10. Is the battery within specifications? ____ Yes ____ No

ACTIVITY

Charging System Voltage Check

1. Turn the ignition ON but do not start the engine.
2. Measure the voltage at the generator terminals B, L and S.
3. Record the voltages in the table below.
4. Start the engine and allow it to idle.
5. Measure the voltage at the generator terminals B, L and S.
6. Record the voltages in the table below.

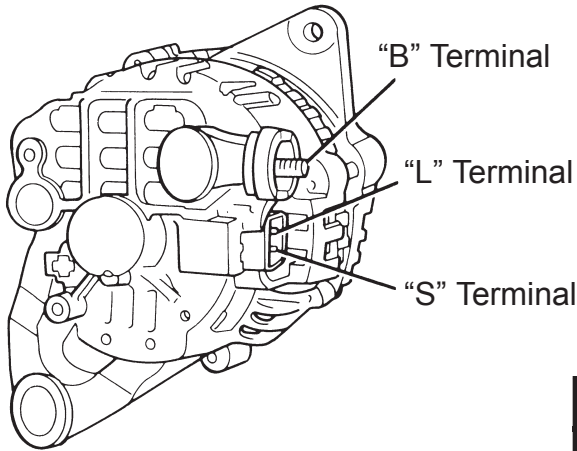

Terminal	Ign: On (V)	Idle (V)
B		
L		
S		

Are the voltage measurements that you got within specifications?

___ Yes ___ No

Specification

Terminal	Ign: On (V)	Idle (V)
B	Approx. 12	14.1 - 14.7
L	Approx. 1	14.1 - 14.7
S	Approx. 12	14.1 - 14.7



ACTIVITY

Charging System Test Using the Snap-On MT-1590 Tester

Using the Snap-On MT-1590 tester, check the charging system.

Alternator Current Output Test

1. *Before performing the alternator output test ensure the battery is fully charged and passes the load test. Also visually inspect the alternator, drive belt and wiring.*
2. *The engine should be at operating temperature and all electrical accessories should be turned **OFF**.*
3. *Connect the load leads across the battery (red to positive and black to negative).*
4. *Zero the AMPS DISPLAY and make sure the ALTERNATOR DIODE TEST FUNCTION is on.*
5. *Make sure tester is in BATTERY VOLTS FUNCTION.*
6. *Clamp the AMPS PROBE around the alternator output wire at least 6" from alternator.*
7. *Adjust the TIMER DISPLAY to 15 seconds.*
8. *Press the ALTERNATOR OUTPUT TEST START key, start engine and set RPM between 2,500 and 3,000 RPM.*
9. *Observe MAXIMUM AMPS reading. Kia minimum specification is 65A.*
10. *Observe ALTERNATOR DIODE TEST DISPLAY for condition of the alternator diodes.*

Voltage Regulator Test

1. *Perform steps 1 - 6 of Alternator Current Output Test.*
2. *Operate engine at moderate speed as required with all accessories off. Allow some running time for the charging system to stabilize (charging system should be at operating temperature).*
3. *Observe VOLTS and AMPS readings. Charging system voltage should be between 13.0 to 15.0 volts with less than 10 amps charging current.*



ACTIVITY

**Starting System Test Using the
Snap-On MT-1590 Tester**

Using the Snap-On MT-1590 tester, check the starting system.

Starting System Test

1. *Perform pre-test: Check battery, wiring, connections and mounting of starter and solenoid.*
2. *Turn off all the vehicle's electrical accessories. Ensure battery is fully charged and that the engine is at shop temperature.*
3. *Disable the ignition or fuel system.*
4. *Connect LOAD LEADS across the battery, red to positive and black to negative.*
5. *Zero AMPS DISPLAY, if it does not read zero.*
6. *Make sure tester is in BATTERY VOLTS FUNCTION.*
7. *Connect the AMPS PROBE around the starter cable.*
8. *Press the TIMER ARROW KEYS to adjust the length of time for the test between 15 to 20 seconds.*
9. *Press the STARTER DRAW TEST START KEY. The TIMER DISPLAY will begin counting down automatically.*
10. *Engage the starter when about 7 seconds are left on the TIMER DISPLAY and continue cranking until the TIMER DISPLAY reads "0", which freezes amps and volts readings.*
11. *Starter draw for a direct drive (MT) starter should be 120 to 200 amps. Starter draw for a gear reduction (AT) starter should be 150 to 250 amps.*

QUICK GENERATOR BENCH TEST

Things you will need:

1. Generator
2. Work bench
3. Power source (i.e.: Fully charged 9v battery)
4. Ammeter
5. 1 red test lead
6. 1 black test lead

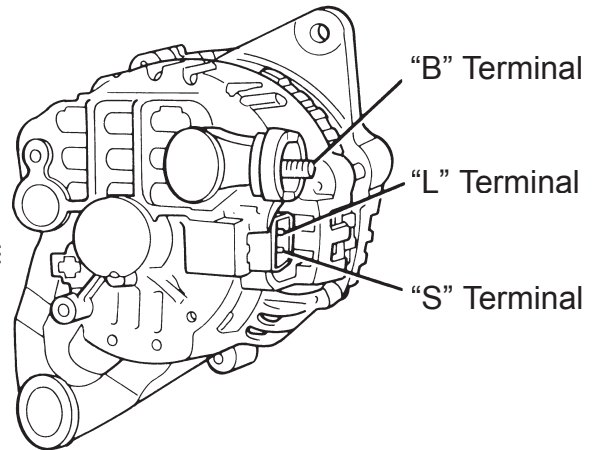

Instructions:

1. Place generator on bench.
2. Make sure ammeter is set to highest scale.
3. Connect the positive (red) lead of ammeter to the B terminal of the generator.
4. Connect the negative (black) lead of the ammeter to the negative (-) terminal of the battery or negative post of the power supply.
5. Connect the black test lead between the generator housing and the negative (-) terminal of the power source.
6. Connect the red test lead between the L terminal of the generator and the positive (+) terminal of the power source.
7. Turn the generator pulley by hand and observe the current reading on the ammeter.

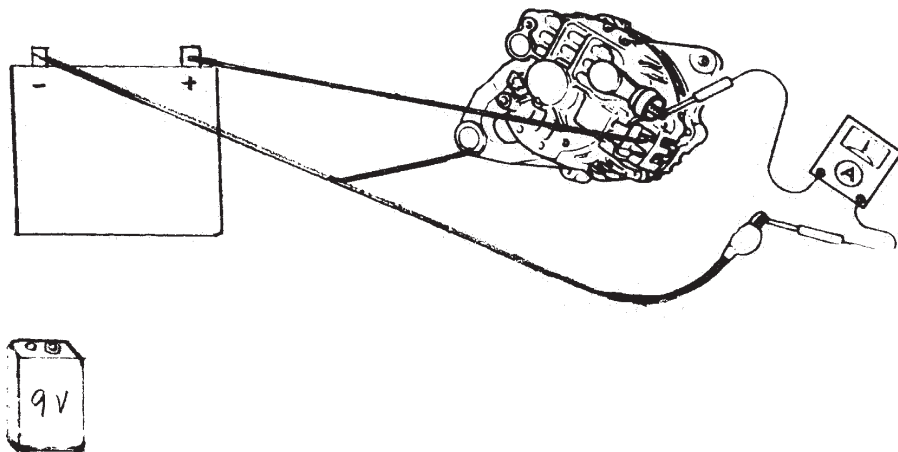

GENERATOR ROTOR INSPECTION

When the generator is found to be defective a bench test can be done on the components of the generator to determine the exact problem within the generator. Two checks can be done to the rotor to determine its serviceability – the open-circuit check and the grounded circuit check. An ohmmeter will be needed to complete these tests.

Open-Circuit Check

Measure the resistance between the slip rings with the ohmmeter. _____ Ω

Is the resistance between **3.5 – 4.5 Ω** ? _____ Yes _____ No

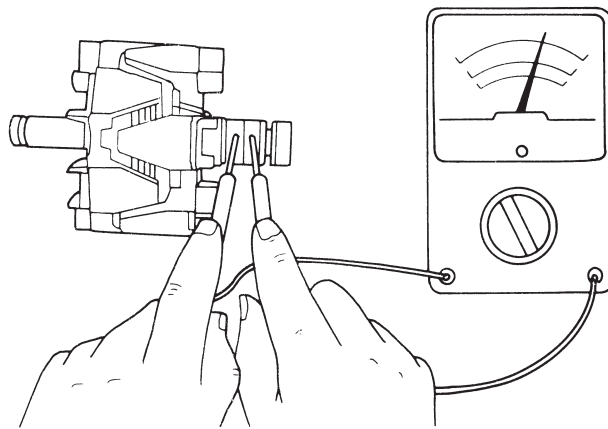

Grounded Circuit Check

Check for resistance between the slip ring and the core.

Was the resistance infinite (∞)? _____ Yes _____ No

The rotor is defective if the resistance is not infinite (∞).

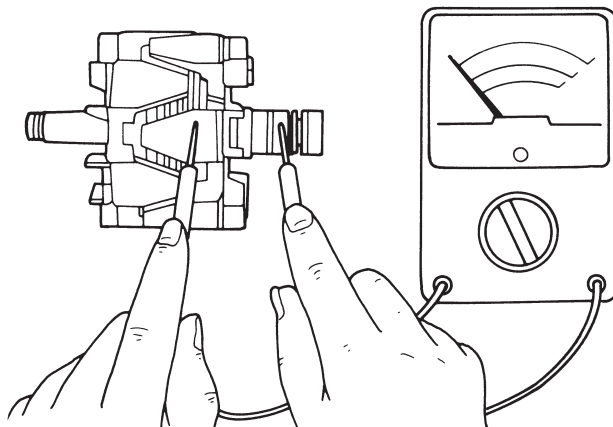

GENERATOR STATOR INSPECTION

When the generator is found to be defective a bench test can be done on the components of the generator to determine the exact problem within the generator.

A continuity check of the stator should be done to determine its serviceability.

An ohmmeter will be needed to complete these tests.

Continuity Between Coil Leads

Check for continuity between the stator coil leads.

Is there continuity between the leads? _____ Yes _____ No

The stator is defective if no continuity.

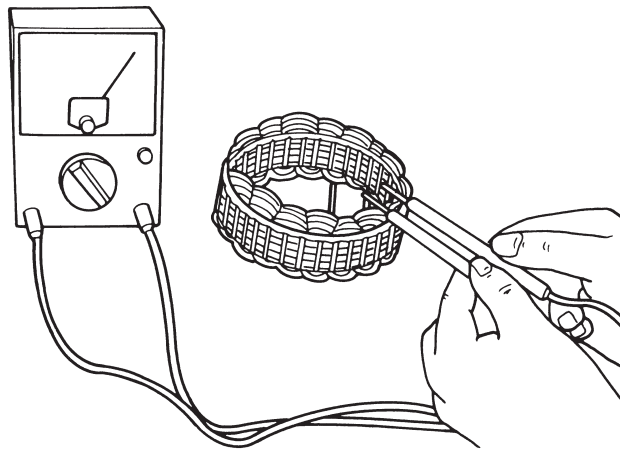

Continuity Between Stator Coil Leads and Core

Check for continuity between the stator coil leads and the core.

Is there continuity between the coil leads and the core?

_____ Yes _____ No

The stator is defective if continuity exists.

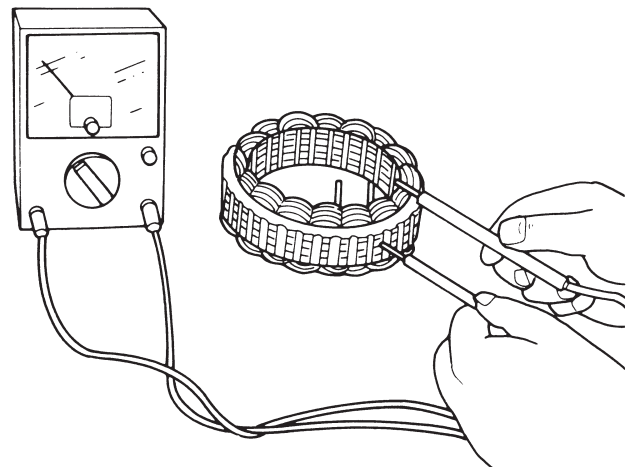

GENERATOR RECTIFIER INSPECTION

When the generator is found to be defective, a bench test can be done on the components of the generator to determine the exact problem within the generator.

A continuity check of the rectifier should be done to determine its serviceability.

An ohmmeter will be needed to complete these tests.

Continuity Between Diodes

Using the table below, check for continuity between each of the terminals.

Negative (Black)	Positive (Red)	Continuity
E	P1, P2, P3	No
B	P1, P2, P3	Yes
T	P1, P2, P3	Yes
P1, P2, P3	E	Yes
P1, P2, P3	B	No
P2, P3	T	No

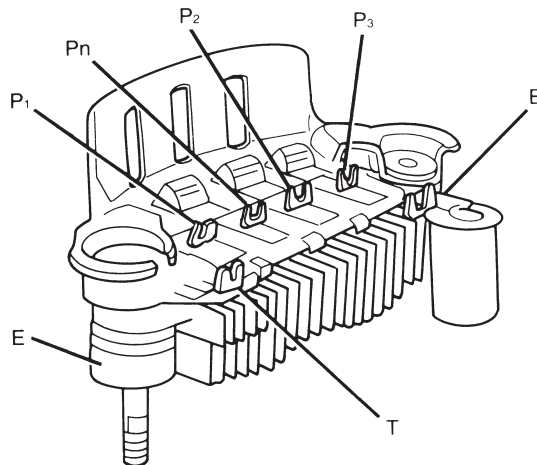

Was the rectifier you checked good or bad? _____ Good _____
Bad

STARTER ARMATURE INSPECTION

1. Check continuity between commutator and core with ohmmeter.

Is continuity present?

Replace armature if there is continuity.

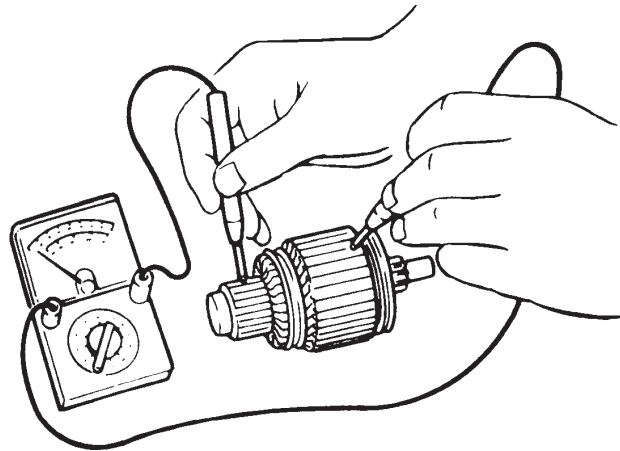

2. Check continuity between commutator and shaft with ohmmeter.

Is continuity present? _____ Yes ___ No

Replace armature if there is continuity.

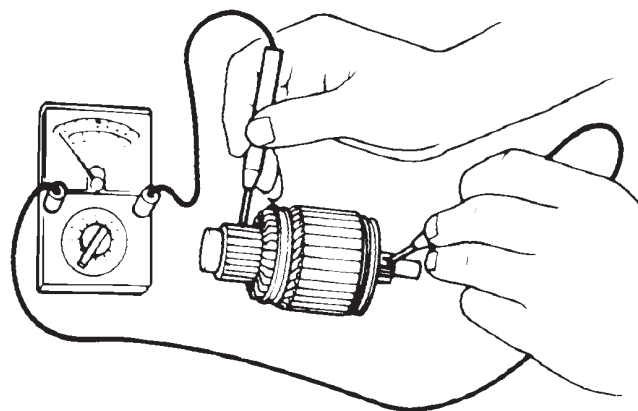

STARTER SOLENOID INSPECTION

1. Check for continuity between S and B terminals with an ohmmeter.

Is continuity present? Yes No

Replace solenoid if there is continuity.

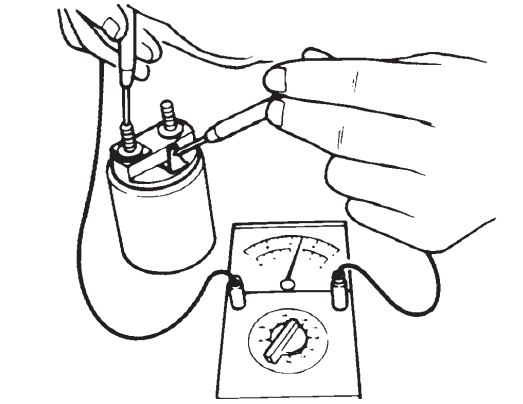

2. Check for continuity between S terminal and solenoid body with ohmmeter.

Is continuity present? Yes No

Replace solenoid if there is no continuity.

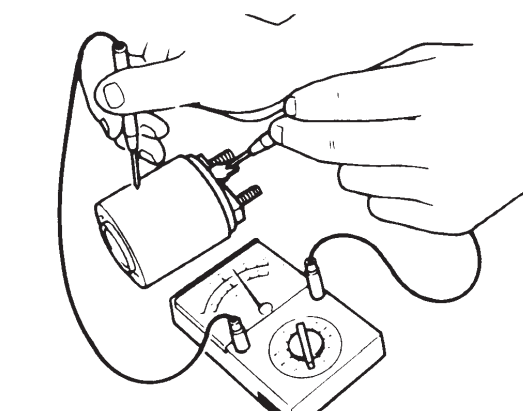

3. Check for continuity between M and B terminals with ohmmeter.

Is continuity present? Yes No

Replace solenoid if there is continuity.

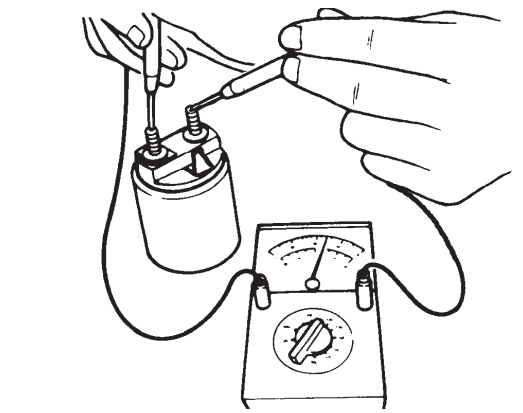

4. Check for continuity between S and M terminals with an ohmmeter.

Is continuity present? Yes No

Replace solenoid if there is no continuity.

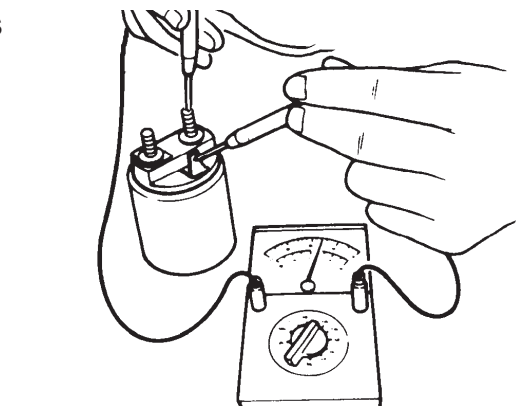

STARTER BRUSH AND BRUSH HOLDER INSPECTION

1. Check brushes for being worn to the wear limit.

Are brushes within limit? _____ Yes _____ No

Standard: 0.67 in (17 mm)

Wear limit: 0.45 in (11.5 mm)

Replace all brushes if not within limit.

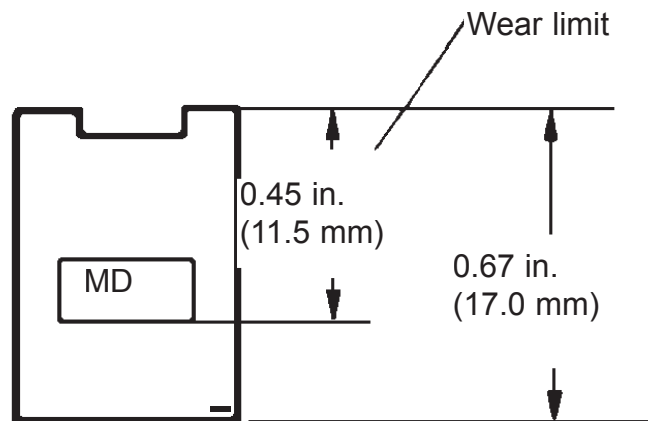

2. Check continuity between each insulated brush and plate with ohmmeter.

Is continuity present?

Replace brush holder if there is continuity.

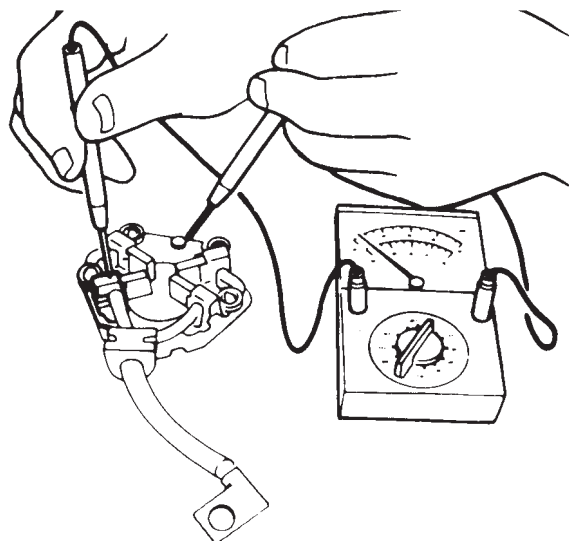

STARTER FIELD COIL INSPECTION

1. Check for continuity between M terminal wire and brushes with ohmmeter.

Is continuity present? _____ Yes ___ No

Replace yoke assembly if there is no continuity.

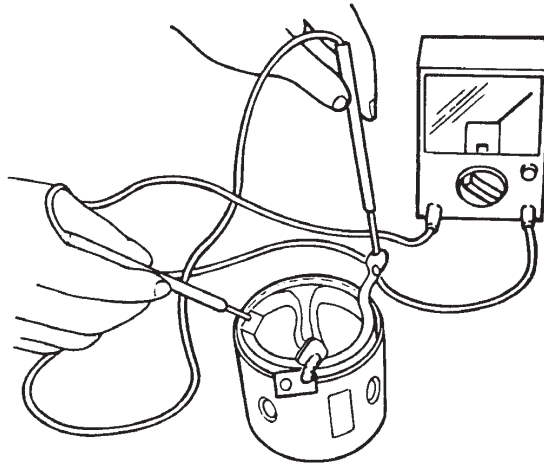

2. Check continuity between M terminal wire and yoke with ohmmeter.

Is continuity present?

Replace yoke assembly if there is continuity.

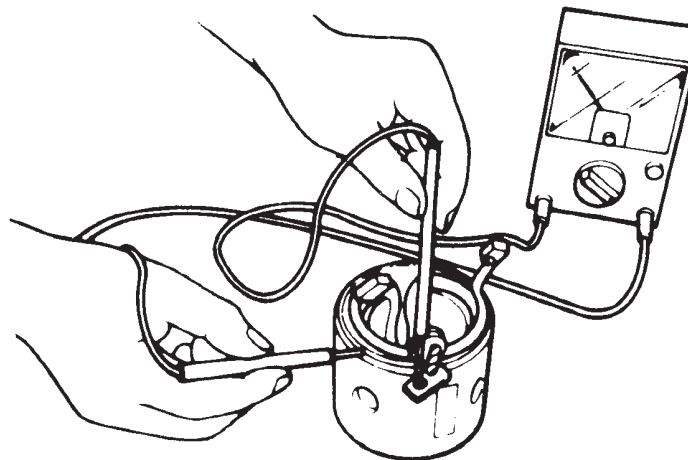

3. Check if field coil is loose.

Is field coil loose? _____ Yes ___ No

Replace yoke assembly if necessary.



WE SUPPORT
VOLUNTARY TECHNICIAN
CERTIFICATION THROUGH

National Institute for
**AUTOMOTIVE
SERVICE
EXCELLENCE**

No part of this publication may be reproduced, stored electronically, or transmitted in any form or by any means without prior written approval from Kia Motors America, Inc. KMA reserves the right to make changes in the descriptions, specifications or procedures without prior notice or obligation.

Copyright © 1999 Kia Motors America, Inc. Corporate Service Training Department

