

## 2007-08 ACCESSORIES AND EQUIPMENT

## Bumpers - Element

## FRONT BUMPER REMOVAL/INSTALLATION

## NOTE:

- Have an assistant help you when removing and installing the front bumper.
- Take care not to scratch the front bumper and body.
- Put on gloves to protect your hands.

1. Remove the front grille cover (see **FRONT GRILLE COVER REPLACEMENT** ).
2. Remove the bolts (A), screws (B, C), and clips (D) securing the front bumper.

## SC model

## Fastener Locations

A ▶ : Bolt, 4    B ▶ : Screw, 2    C ▶ : Screw, 2



D ▷ : Clip, 11

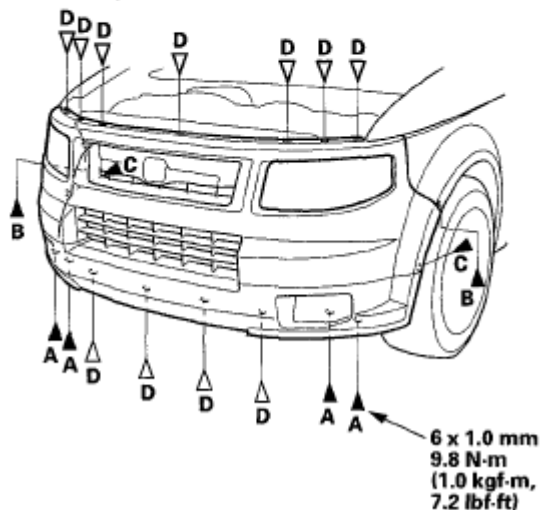

**Fig. 1: Identifying Bolts, Screws, And Clips Securing Front Bumper With Torque Specifications (For SC Model)**

Courtesy of AMERICAN HONDA MOTOR CO., INC.

LX, EX models

## 2007 Honda Element EX

2007-08 ACCESSORIES AND EQUIPMENT Bumpers - Element

### Fastener Locations

A ▶ : Bolt, 4    B ▶ : Screw, 2    D ▶ : Clip, 13

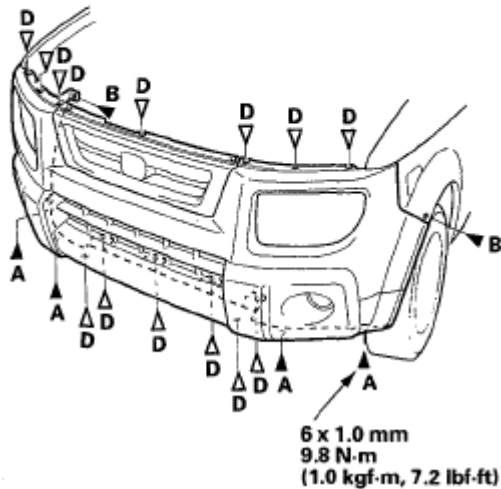

**Fig. 2: Identifying Bolts, Screws, And Clips Securing Front Bumper With Torque Specifications (For LX, EX Models)**

Courtesy of AMERICAN HONDA MOTOR CO., INC.

3. Pull on the front bumper (A) at the wheel arch areas to release it from the hooks (B) on the side spacers (C) and front fender cladding (D).

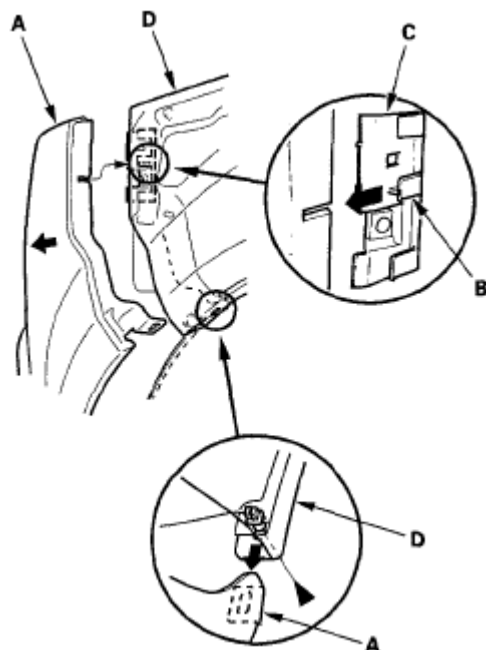

**Fig. 3: Pulling On Front Bumper At Wheel Arch Areas**

Courtesy of AMERICAN HONDA MOTOR CO., INC.

## 2007 Honda Element EX

### 2007-08 ACCESSORIES AND EQUIPMENT Bumpers - Element

4. SC model: With the help of an assistant, while pulling the wheel arch portion away from the front fender cladding (A), pull out on the front bumper (B) to release the bumper from the hooks (C) on the center upper beam (D). Remove the front bumper.

#### SC model

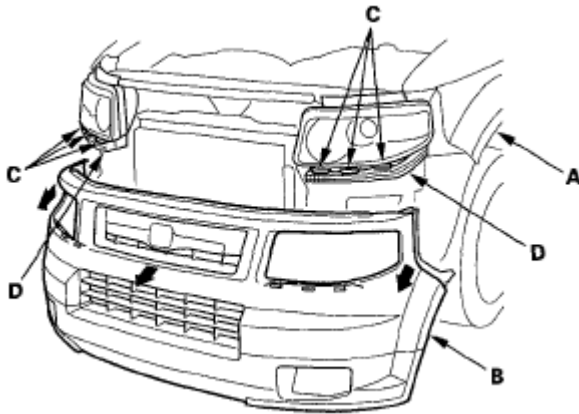

**Fig. 4: Identifying Front Fender Cladding (For SC Model)**  
Courtesy of AMERICAN HONDA MOTOR CO., INC.

5. LX, EX models: With the help of an assistant, while pulling the wheel arch portion away from the front fender cladding (A), pull out on the front bumper (B) and remove it.

#### LX, EX models

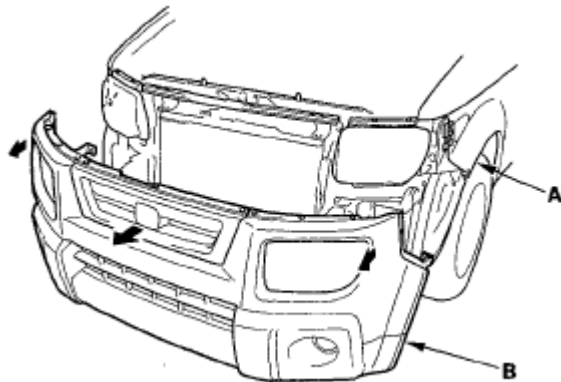

**Fig. 5: Identifying Front Fender Cladding (For LX, EX Models)**  
Courtesy of AMERICAN HONDA MOTOR CO., INC.

6. Install the bumper in the reverse order of removal, and note these items:
  - Make sure the front bumper engages the hooks (of both corner upper beams (SC model), front fender claddings and side spacers) on each side securely.
  - Push the clips and hooks into place securely.
  - Check if the clips are damaged or stress-whitened, and if necessary, replace them with new ones.

## FRONT BUMPER DISASSEMBLY/REASSEMBLY

### SC MODEL

#### NOTE:

- Take care not to scratch the front bumper faces.
- Put on gloves to protect your hands.

1. Remove the front bumper (see **FRONT BUMPER REMOVAL/INSTALLATION** ).
2. Remove the bolt (A) and clips (B) securing the front bumper upper face (C) and the front bumper lower face (D).

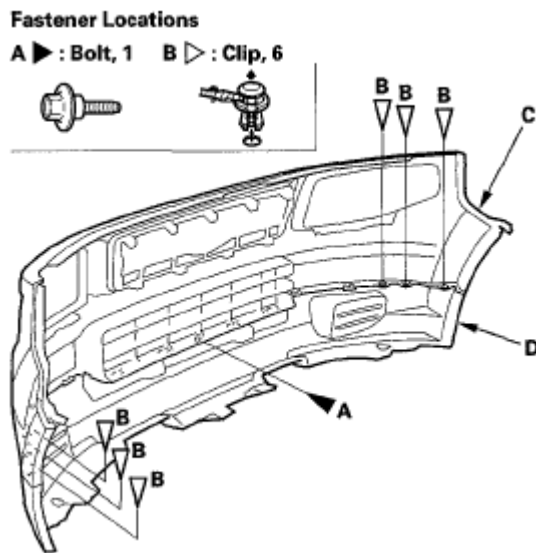

**Fig. 6: Identifying Bolt And Clips Securing Front Bumper Upper Face And Front Bumper Lower Face**

Courtesy of AMERICAN HONDA MOTOR CO., INC.

3. With the help of an assistant, detach the hooks (A) and separate the front bumper upper face (B) from the front bumper lower face (C).

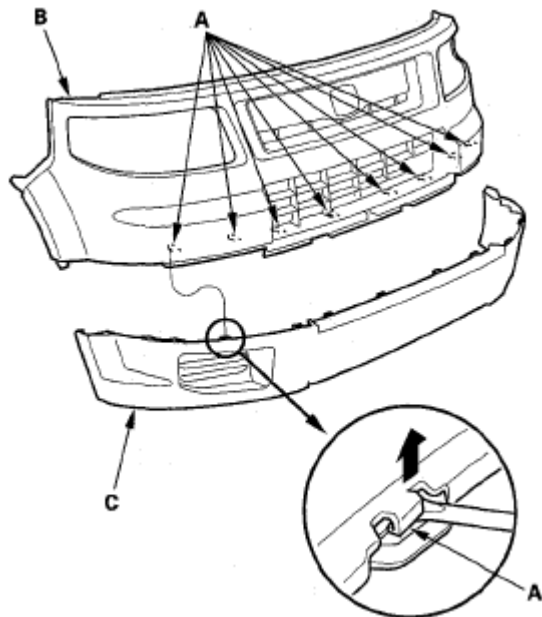

**Fig. 7: Identifying Front Bumper Upper And Lower Face Hooks**  
Courtesy of AMERICAN HONDA MOTOR CO., INC.

4. Reassemble the bumper faces in the reverse order of removal, and note these items:
  - Push the clips and hooks into place securely.
  - Check if the clips are damaged or stress-whitened, and if necessary, replace them with new ones.

## FRONT BUMPER TRIM REPLACEMENT

### LX, EX MODELS

1. Remove the clips, and release the hooks (A), then remove the front bumper trim (B) from the front bumper (C) by pulling it out. Take care not to scratch the front bumper.

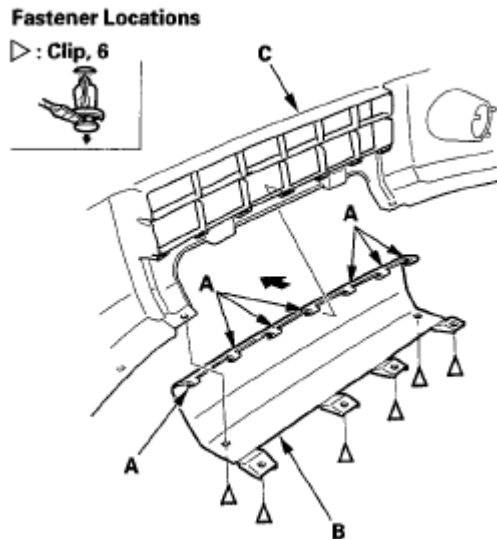

**Fig. 8: Identifying Front Bumper Trim, Clips And Hooks**  
Courtesy of AMERICAN HONDA MOTOR CO., INC.

2. Install the trim in the reverse order of removal, and note these items:
  - Check if the clips are damaged or stress-whitened, and if necessary, replace them with new ones.
  - Push the hook portions into place securely.

## REAR BUMPER REMOVAL/INSTALLATION

**NOTE:**

- Have an assistant help you when removing and installing the rear bumper.
- Take care not to scratch the rear bumper and body.
- Put on gloves to protect your hands.

1. Remove the screws (A, B), bolts (C) and clips (D) securing the rear bumper (E).

## 2007 Honda Element EX

2007-08 ACCESSORIES AND EQUIPMENT Bumpers - Element

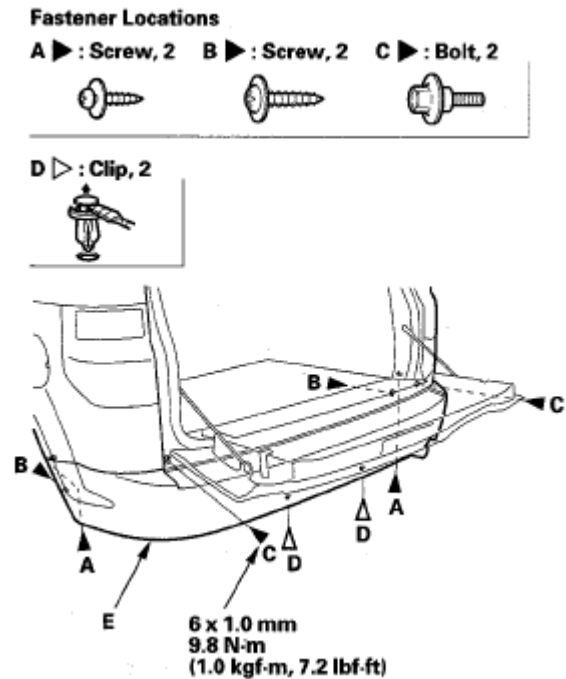

**Fig. 9: Identifying Screws Bolts And Clips Securing Rear Bumper**  
Courtesy of AMERICAN HONDA MOTOR CO., INC.

2. Pull on the rear bumper (A) at the wheel arch areas to release it from the hooks (B) on the upper bracket (C).

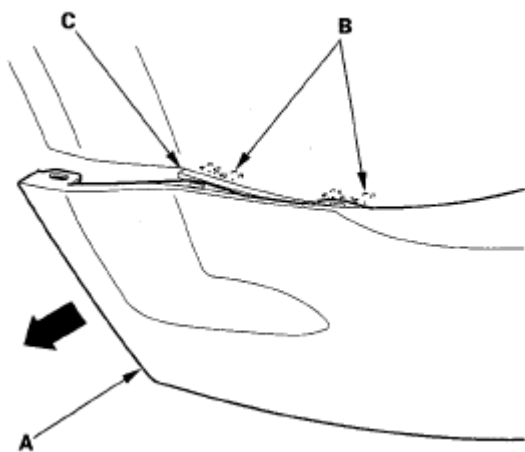

**Fig. 10: Pulling On Rear Bumper At Wheel Arch Areas**  
Courtesy of AMERICAN HONDA MOTOR CO., INC.

3. With the help of an assistant, while pulling the wheel arch portion away from the upper bracket (A), pull the rear bumper to release the bumper from the hook (B) on the bumper support bracket (C).

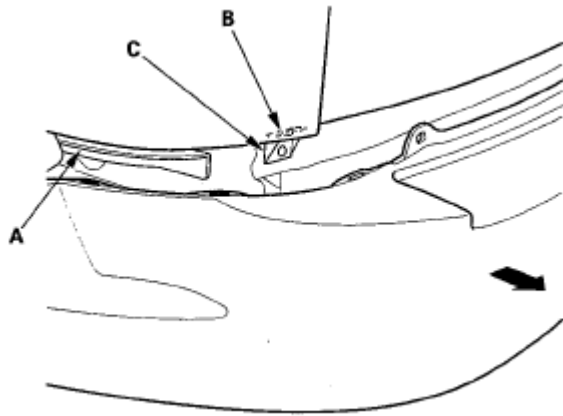

**Fig. 11: Identifying Bumper Support Bracket**  
Courtesy of AMERICAN HONDA MOTOR CO., INC.

4. With the help of an assistant, pull the rear bumper (A) to release the rear bumper from the hooks (B).

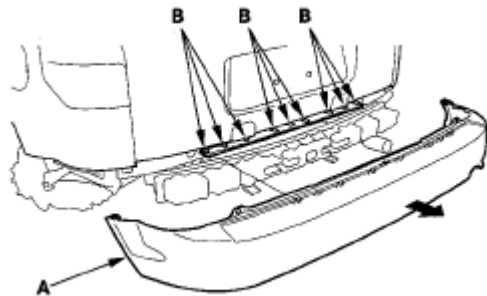

**Fig. 12: Identifying Rear Bumper Hooks**  
Courtesy of AMERICAN HONDA MOTOR CO., INC.

5. Using a flat-tip screwdriver, release the hooks (A) from the under portion of the absorber, then release the hooks. Pull out the rear bumper absorber (B) to remove it from the rear bumper beam (C).



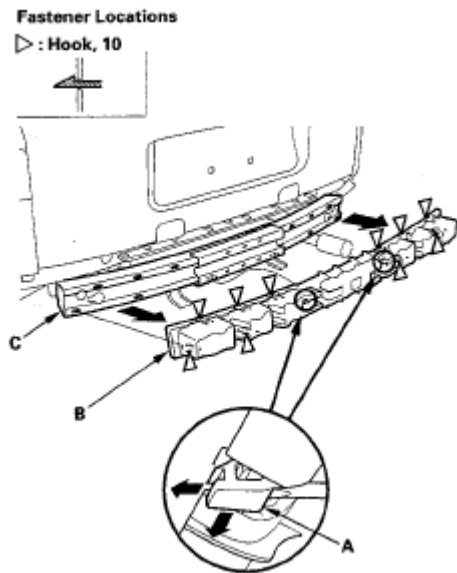

**Fig. 13: Identifying Rear Bumper Beam**

Courtesy of AMERICAN HONDA MOTOR CO., INC.

6. Install the bumper in the reverse order of removal, and note these items:
  - Make sure the rear bumper engages the hooks (of both the upper bracket and bumper support bracket) on each side securely.
  - Push the clips and hooks into place securely.
  - Check if the clips are damaged or stress-whitened, and if necessary, replace them with new ones.

## REAR BUMPER TRIM REPLACEMENT

### LX, EX MODELS

1. Remove the rear bumper (see **REAR BUMPER REMOVAL/INSTALLATION** ).
2. Remove the clips, and release the hooks (A), then remove the rear bumper trim (B) from the rear bumper (C) by pulling it out. Take care not to scratch the rear bumper.

**Fastener Locations**

▷ : Clip, 5

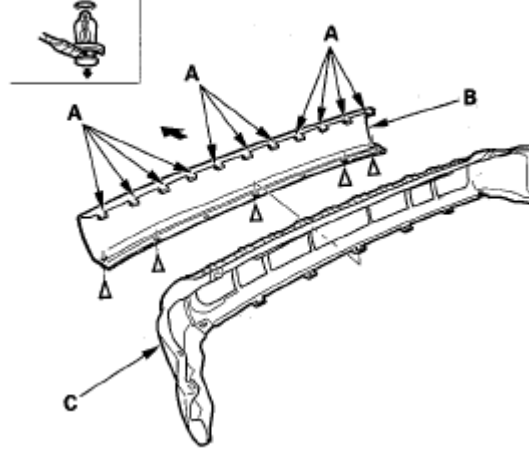

**Fig. 14: Identifying Rear Bumper Trim Clips And Hooks**  
Courtesy of AMERICAN HONDA MOTOR CO., INC.

3. Install the trim in the reverse order of removal, and note these items:
  - Check if the clips are damaged or stress-whitened, and if necessary, replace them with new ones.
  - Push the hook portions into place securely.