

CABIN AIR FILTERS

Dust & Pollen Filter - Element & RSX

REMOVAL & INSTALLATION

NOTE: Manufacturer's terminology for this filter is dust and pollen filter.

CABIN AIR FILTER

Removal & Installation

1. Open the glove box. Remove the glove box stop on each side, then hang the glove box down. See [Fig. 1](#).

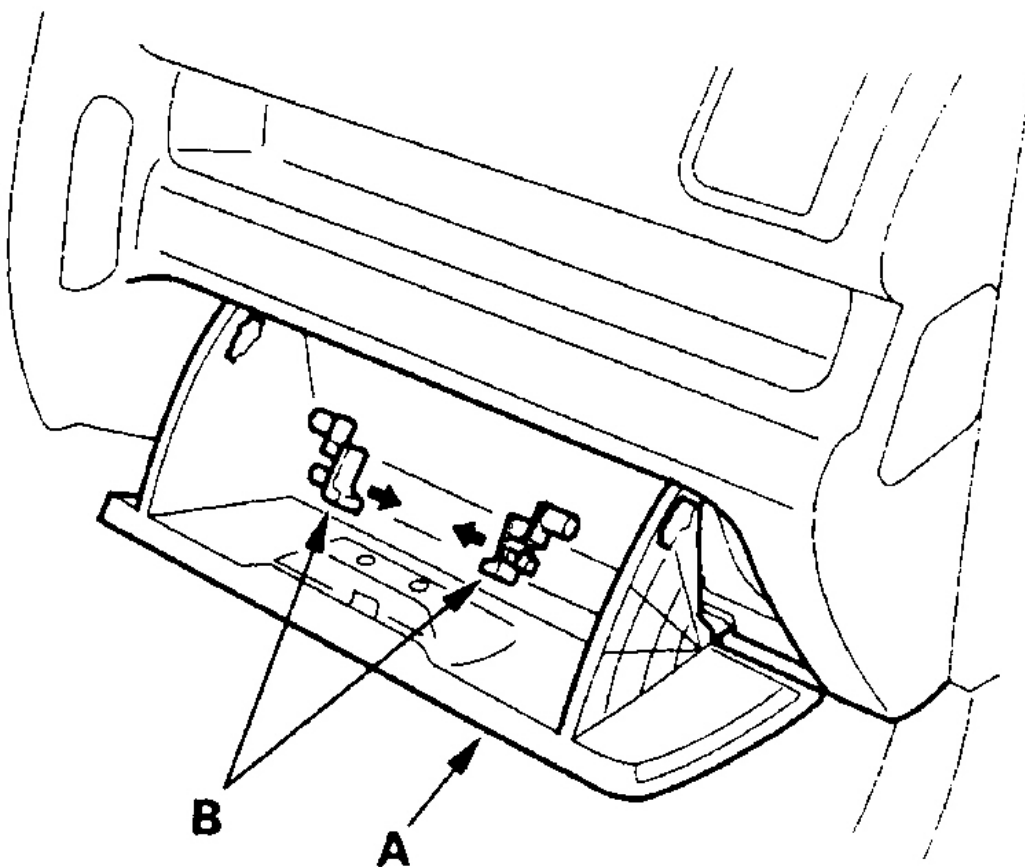

G00206677

Fig. 1: Releasing Glove Box Stops

Courtesy of AMERICAN HONDA MOTOR CO., INC.

2. Remove the filter lid from the blower unit, then pull out the first dust and pollen filter. Slide the second filter to the left and pull it out. See **Fig. 2**.

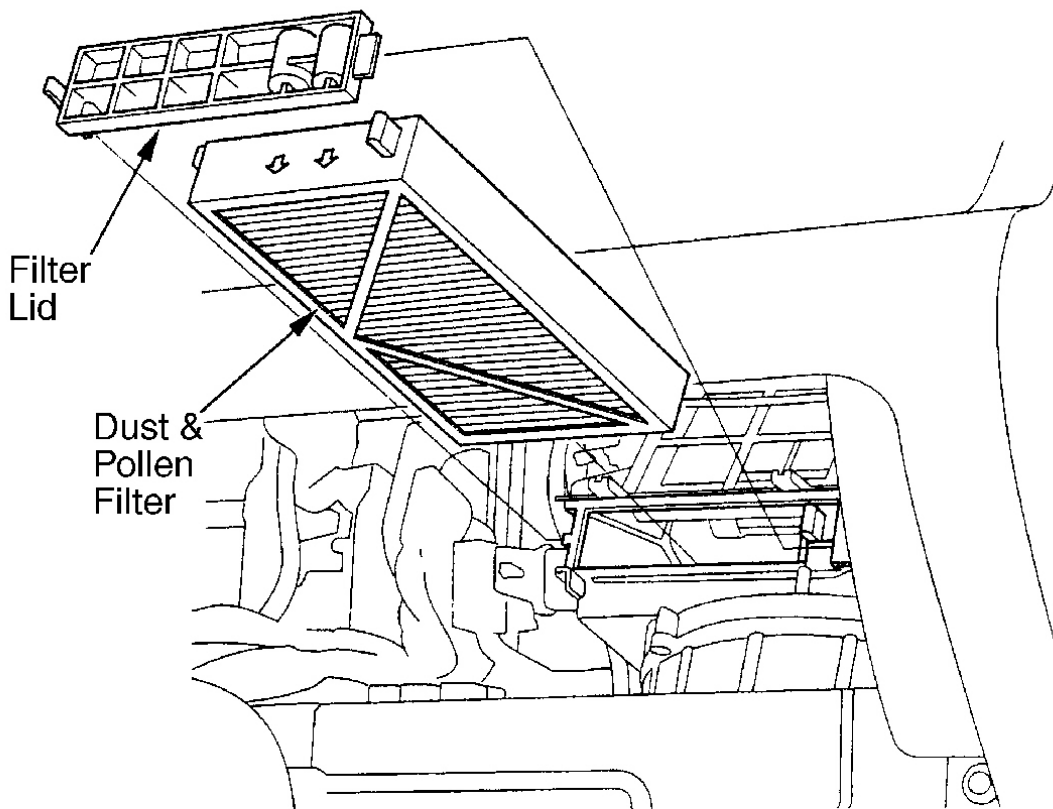

G00206676

Fig. 2: Removing Filter Lid From Blower Unit
Courtesy of AMERICAN HONDA MOTOR CO., INC.

3. Remove the filter from the housing and replace the filter. See **Fig. 3**.
4. To install the filter, reverse removal procedure. Ensure arrow marks on edge of filter face in direction of air flow.

2007 Honda Element EX

CABIN AIR FILTERS Dust & Pollen Filter - Element & RSX

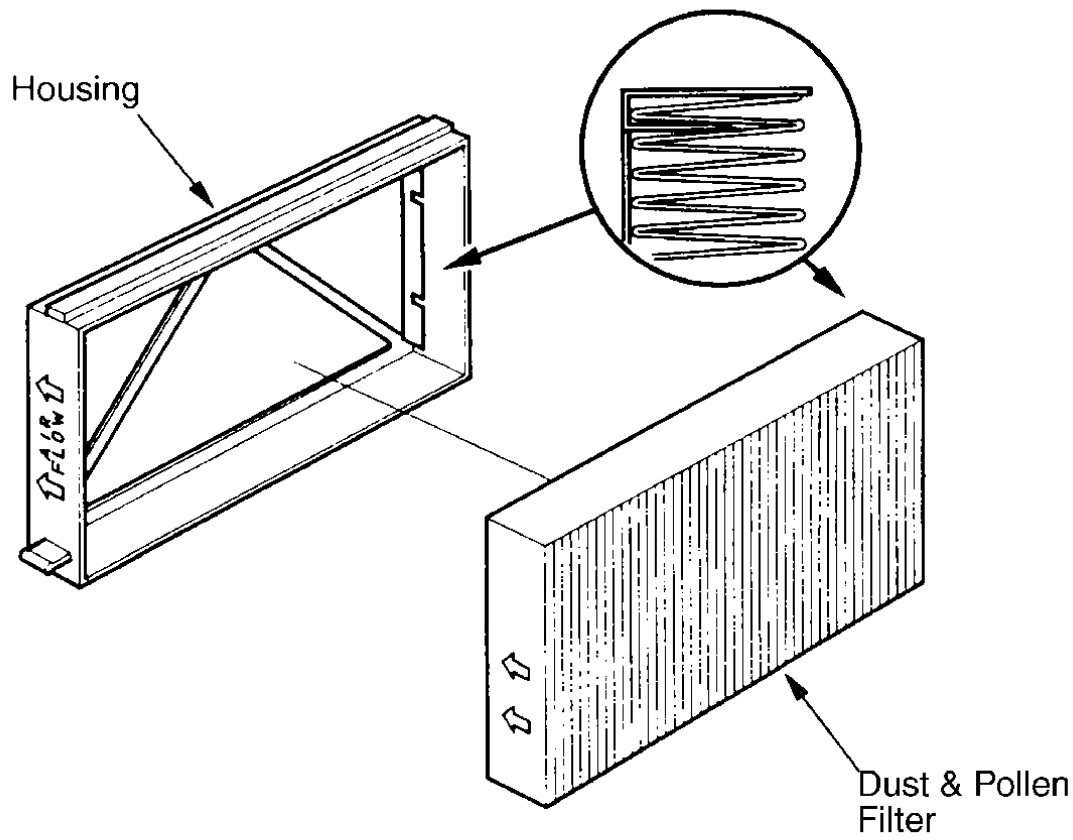

G00206678

Fig. 3: Removing Dust & Pollen Filter From Housing
Courtesy of AMERICAN HONDA MOTOR CO., INC.