

2004 Honda Element DX

2003-06 BRAKES Conventional Brake Components - Element

2003-06 BRAKES

Conventional Brake Components - Element

SPECIAL TOOLS

Ref. No.	Tool Number	Description	Qty
①	07JAG-SD40100	Pushrod Adjustment Gauge	1

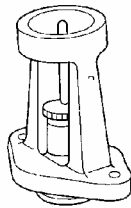

G03679147

Fig. 1: Identifying Conventional Brake Special Tools
Courtesy of AMERICAN HONDA MOTOR CO., INC.

COMPONENT LOCATION INDEX

2004 Honda Element DX

2003-06 BRAKES Conventional Brake Components - Element

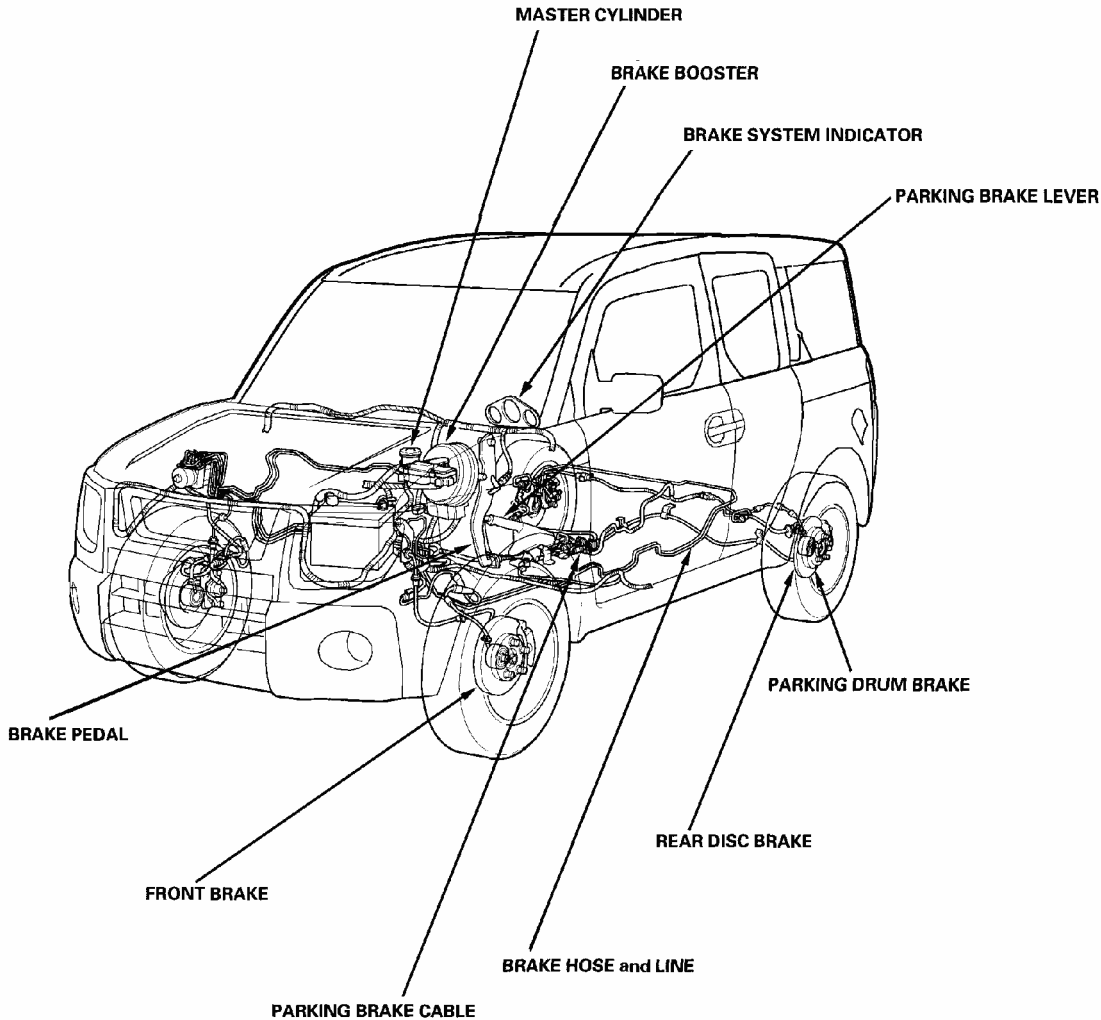

G03679148

Fig. 2: Identifying Component Locations

Courtesy of AMERICAN HONDA MOTOR CO., INC.

BRAKE SYSTEM INSPECTION AND TEST

Inspect the brake system components listed. Repair or replace any parts that are leaking or damaged.

Component Inspections:

COMPONENT INSPECTIONS REFERENCE CHART

Component	Procedure	Also check for:
Master Cylinder	Look for damage or signs of fluid leakage at: <ul style="list-style-type: none">• Reservoir or reservoir	Bulging seal at reservoir cap. This is a sign of fluid contamination.

2004 Honda Element DX

2003-06 BRAKES Conventional Brake Components - Element

	<p>grommets</p> <ul style="list-style-type: none">• Line joints• Between master cylinder and booster	
Brake Hoses	<p>Look for damage or signs of fluid leakage at:</p> <ul style="list-style-type: none">• Line joints and banjo bolt connections• Hoses and lines, also inspect for twisting or damage	Bulging, twisted, or bent lines.
Caliper	<p>Look for damage or signs of fluid leakage at:</p> <ul style="list-style-type: none">• Piston seal• Banjo bolt connections• Bleed screw	Seized or sticking caliper pins.
ABS Modulator-control Unit	<p>Look for damage or signs of fluid leakage at:</p> <ul style="list-style-type: none">• Line joints• Modulator-control unit	

BRAKE SYSTEM TEST

Brake pedal sinks/fades when braking

1. Start the engine, and let it warm up to operating temperature.
2. Attach a 50 mm (2 in.) piece of masking tape along the bottom of the steering wheel, and draw a horizontal reference mark across it.
3. With the transmission in Neutral, press and hold the brake pedal lightly (about the same pressure needed to keep an A/T-equipped vehicle from creeping), then release the parking brake.
4. While still holding the brake pedal, hook the end of the tape measure behind it. Then pull the tape up to the steering wheel, noting where the tape measure lines up with the reference mark you made on the masking tape.
5. Apply steady pressure to the brake pedal for 3 minutes.
6. Watch the tape measure.
 - If it moves less than 10 mm (3/8 in.), the master cylinder is OK.
 - If it moves more than 10 mm (3/8 in.), replace the master cylinder.

NOTE: If the brake pedal sinks more than 10 mm (3/8 in.) in 3 minutes, the master cylinder is faulty. A slight change in pedal height when the A/C compressor cycles on and off is normal. (The A/C compressor load changes the vacuum available to the brake booster.)

SYMPTOM TROUBLESHOOTING

RAPID BRAKE PAD WEAR, VEHICLE VIBRATION (AFTER A LONG DRIVE), OR HIGH, HARD BRAKE PEDAL

NOTE: Make sure that the caliper pins are installed correctly.

The upper and lower caliper pins are different. If the top and bottom caliper pins are installed in the wrong location, it will cause uneven tire wear, vibration, and/or uneven or rapid pad wear for proper caliper pin location (see **FRONT BRAKE CALIPER OVERHAUL**).

1. Drive the vehicle until the brakes drag or until the pedal is high and hard. This can take 20 or more brake pedal applications during an extended test-drive.
2. With the engine running, raise the vehicle on a lift, and spin all four wheels by hand.

Is there brake drag at any of the wheels?

YES - Go to step 3 .

NO - Look for other causes of the pad wear, high pedal, or vehicle vibration.

3. Turn the engine off, pump the brake pedal to deplete the vacuum in the brake booster, and then spin the wheels again to check for brake drag.

Is there brake drag at any of the wheels?

YES - Go to step 4 .

NO - Replace the brake booster (see)**BRAKE BOOSTER REPLACEMENT** .

4. Without removing the brake lines, unbolt and separate the master cylinder from the booster, then spin the wheels to check for brake drag.

Is there brake drag at any of the wheels?

YES - Go to step 5 .

NO - Check the brake pedal position switch adjustment and pedal free play.

5. Loosen the hydraulic lines at the master cylinder, then spin the wheels to check for brake drag.

Is there brake drag at any of the wheels?

YES - Go to step 6 .

NO - Replace the master cylinder (see)**MASTER CYLINDER REPLACEMENT**

6. Loosen the bleed screws at each caliper, then spin the wheels to check for brake drag.

Is there brake drag at any of the wheels?

YES - Disassemble and repair the caliper on the wheel(s) with brake drag.

NO - Look for a bulging master cylinder cap seal, discolored or contaminated brake fluid in the master cylinder, or damaged brake lines. If any of these items are damaged, replace them. If all of these items are OK, replace the ABS modulator-control unit (see **ABS MODULATOR-CONTROL UNIT REMOVAL AND INSTALLATION**).

BRAKE PEDAL AND BRAKE PEDAL POSITION SWITCH ADJUSTMENT

PEDAL HEIGHT

1. Turn the brake pedal position switch (A) counterclockwise, and pull it back until it is no longer touching the brake pedal.

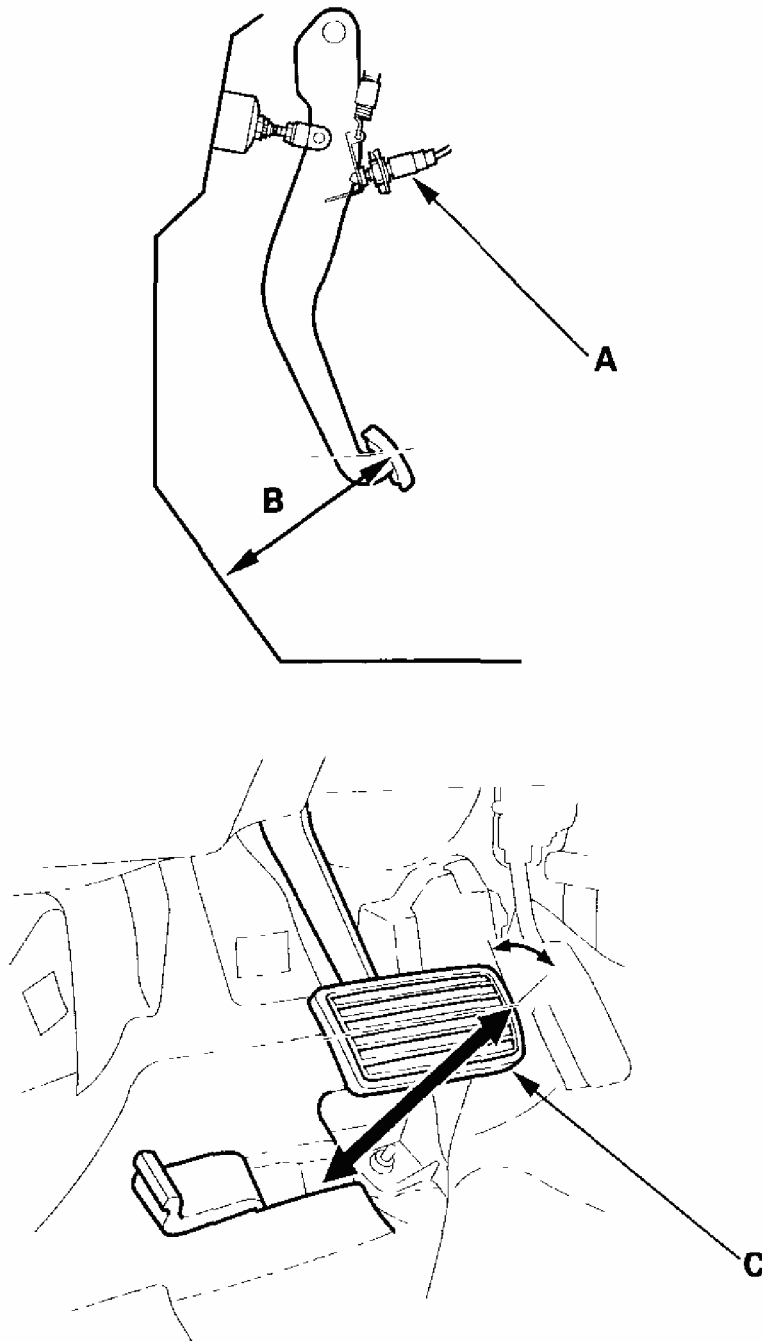

G03679149

Fig. 3: Identifying Brake Pedal And Brake Pedal Position Switch
Courtesy of AMERICAN HONDA MOTOR CO., INC.

2. Lift up the carpet. At the insulator cutout, measure the pedal height (B) from the middle of the pedal pad (C).

Standard pedal height (with carpet removed):

M/T: 178 mm (7 in.)

A/T: 180 mm (7 3/32 in.)

3. Loosen the pushrod locknut (A), and screw the pushrod in or out with pliers on the knurled part of the pushrod (B), until the standard pedal height from the floor is reached. After adjustment, tighten the locknut firmly. Do not adjust the pedal height with the pushrod pressed.

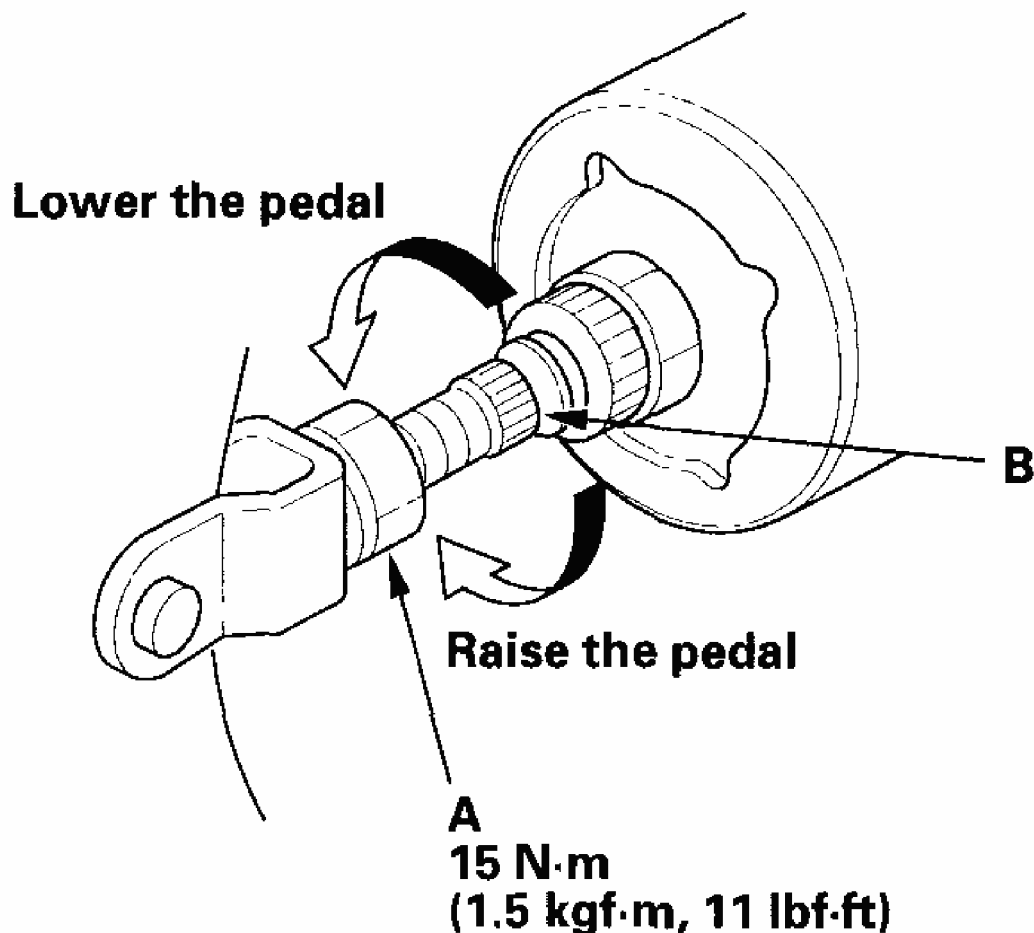

G03679150

Fig. 4: Loosening Pushrod Locknut For Adjustment And Torque Specifications
Courtesy of AMERICAN HONDA MOTOR CO., INC.

4. Push in the brake pedal position switch until its plunger is fully pressed (threaded end (A) touching the pad (B) on the pedal arm). Then, turn the switch 45° clockwise to lock it. The gap between the brake pedal position switch and the pad is automatically

adjusted to 0.7 mm (0.03 in.) by locking the switch. Make sure the brake lights go off when the pedal is released.

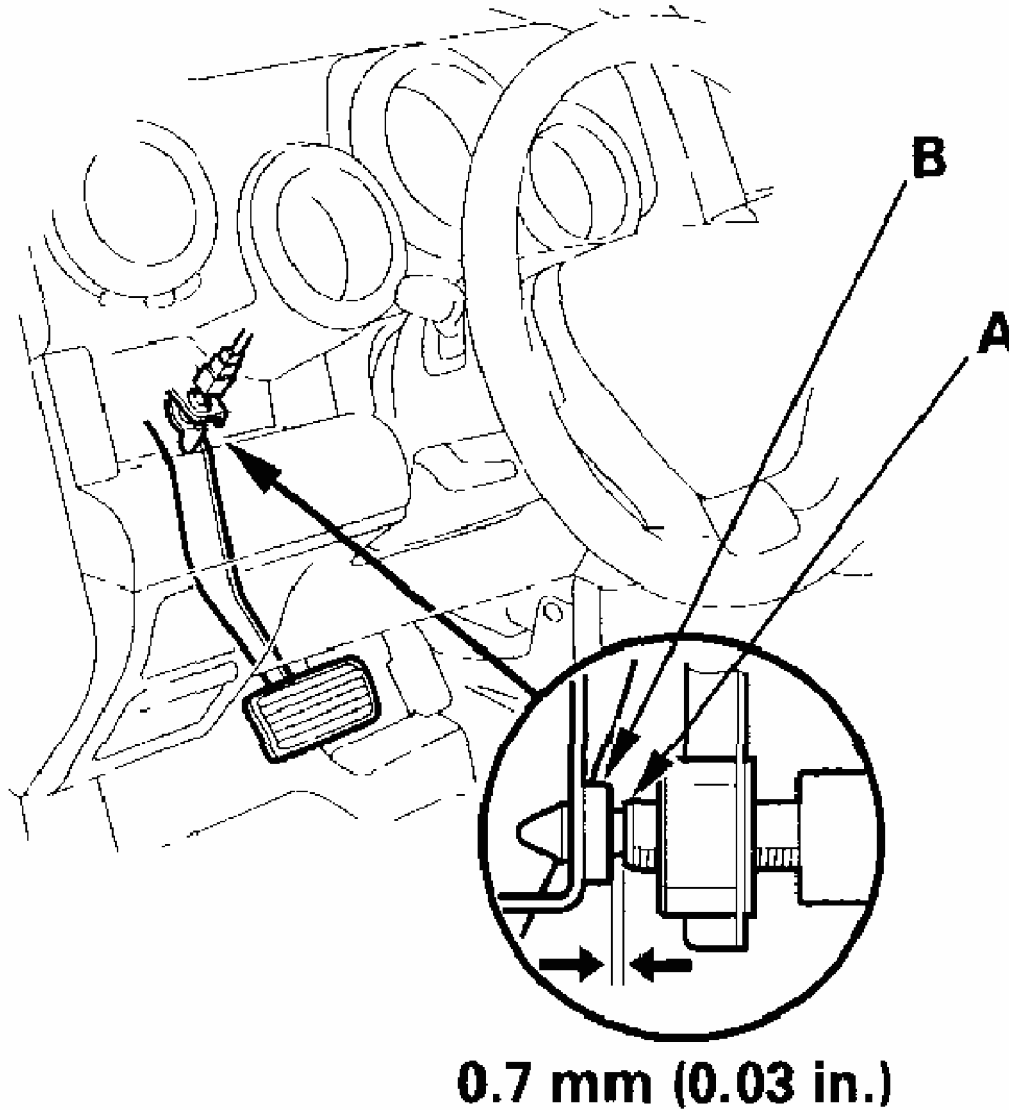

G03679151

Fig. 5: Pushing Brake Pedal Position Switch Until Plunger Is Fully Pressed
Courtesy of AMERICAN HONDA MOTOR CO., INC.

5. Check the brake pedal free play.

PEDAL FREE PLAY

1. With the engine off, inspect the play (A) on the brake pedal pad (B) by pushing the brake pedal by hand.

Free play: 1-5 mm (1/16-3/16 in.)

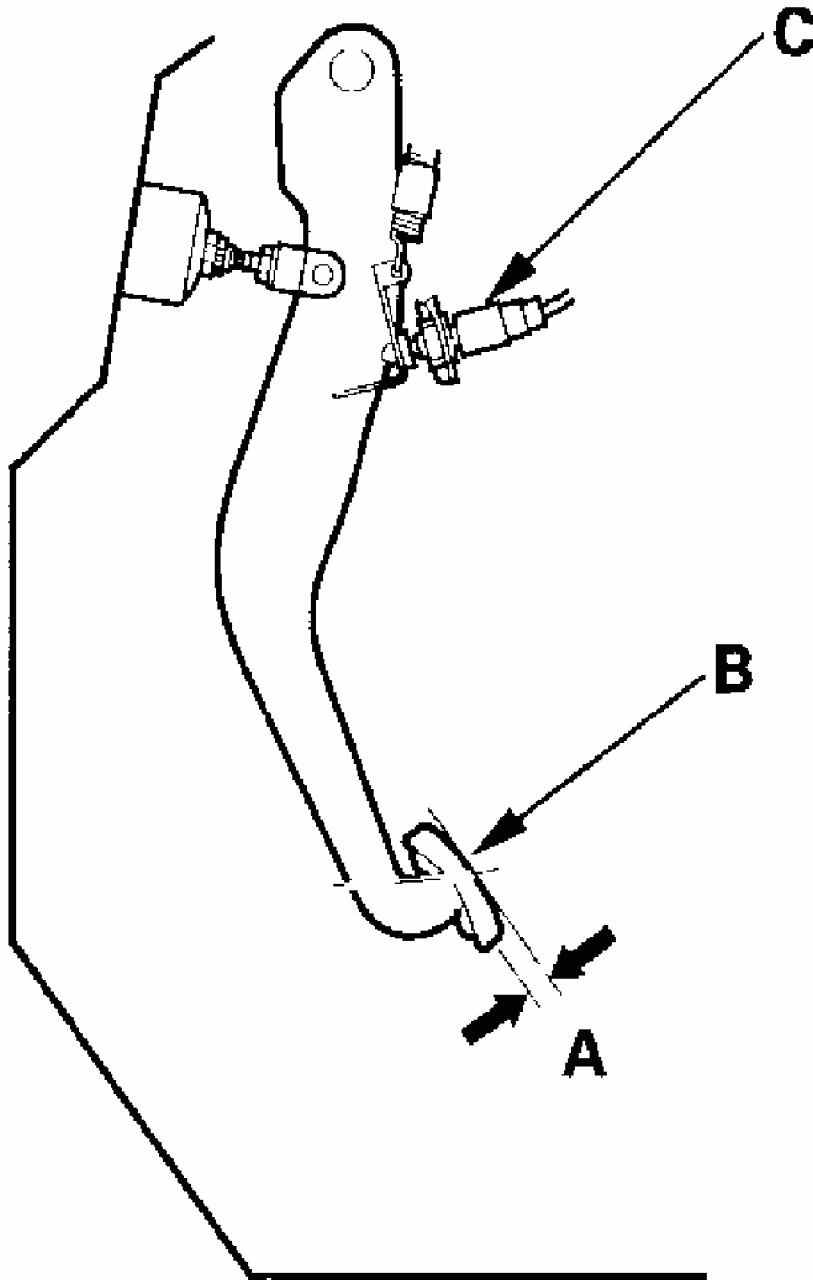

G03679152

Fig. 6: Identifying Pedal Free Play
Courtesy of AMERICAN HONDA MOTOR CO., INC.

2. If the brake pedal free play is out of specification, adjust the brake pedal position switch (C). If the brake pedal free play is insufficient, it may result in excessive brake drag.

PARKING BRAKE CHECK AND ADJUSTMENT

CHECK

1. Pull the parking brake lever (A) with 196 N (20 kgf, 44 lbf) of force to fully apply the parking brake. The parking brake lever should be locked within the specified number of clicks (B).

Lever locked clicks: 4 to 7

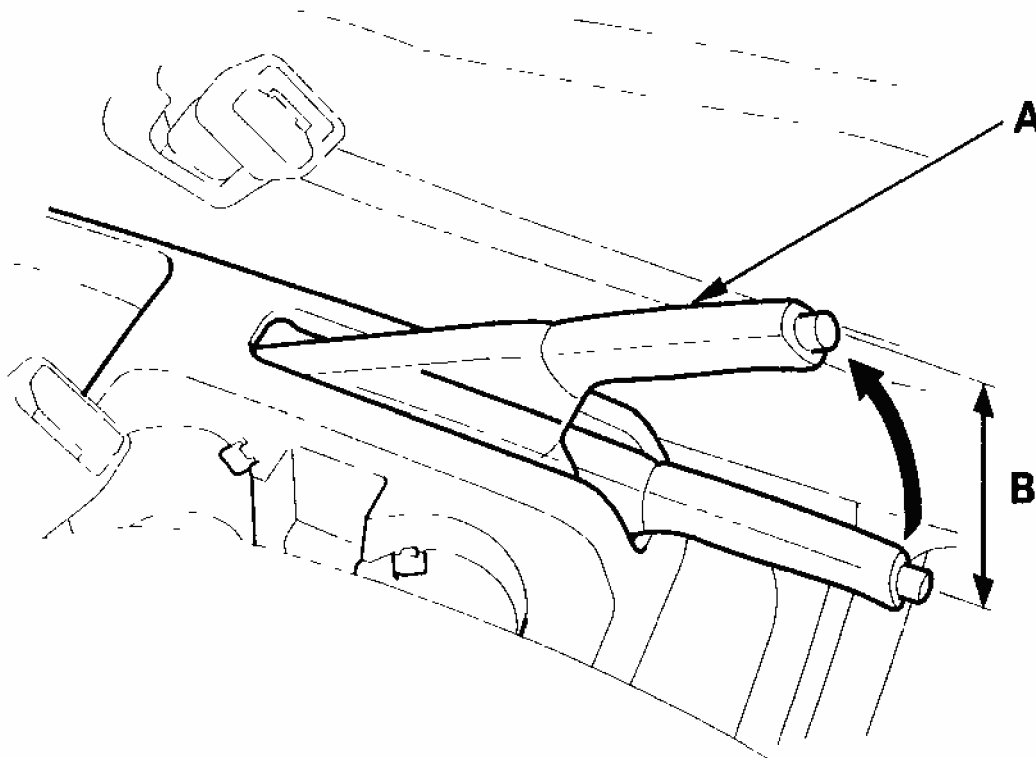

G03679153

Fig. 7: Pulling Parking Brake Lever Fully
Courtesy of AMERICAN HONDA MOTOR CO., INC.

2. Adjust the parking brake if the lever clicks are not within the specification.

MINOR ADJUSTMENT

1. Raise the rear of the vehicle, and support it with safety stands in the proper locations (see **SAFETY STANDS**).
2. Release the parking brake lever fully.
3. Remove the center console (see **CENTER CONSOLE REMOVAL/INSTALLATION**).
4. Pull the parking brake lever 1 click.

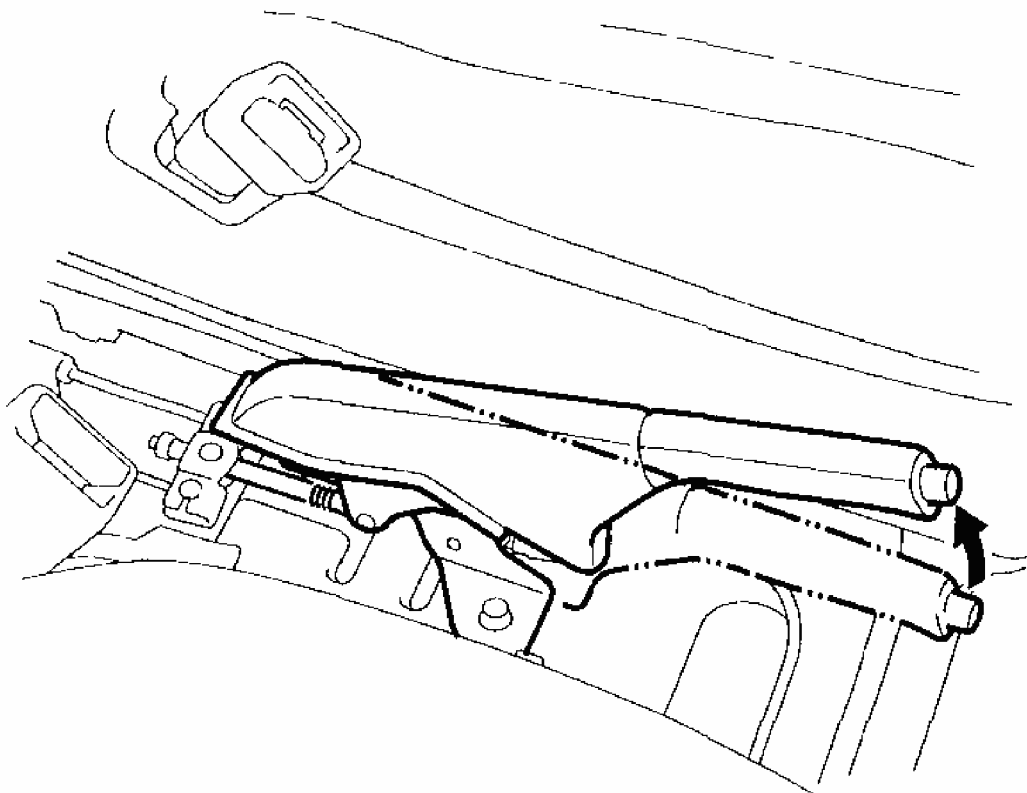

G03679154

Fig. 8: Pulling The Parking Brake Lever 1 Click
Courtesy of AMERICAN HONDA MOTOR CO., INC.

5. Tighten the adjusting nut (A) until the parking brakes drag slightly when the rear wheels are turned.

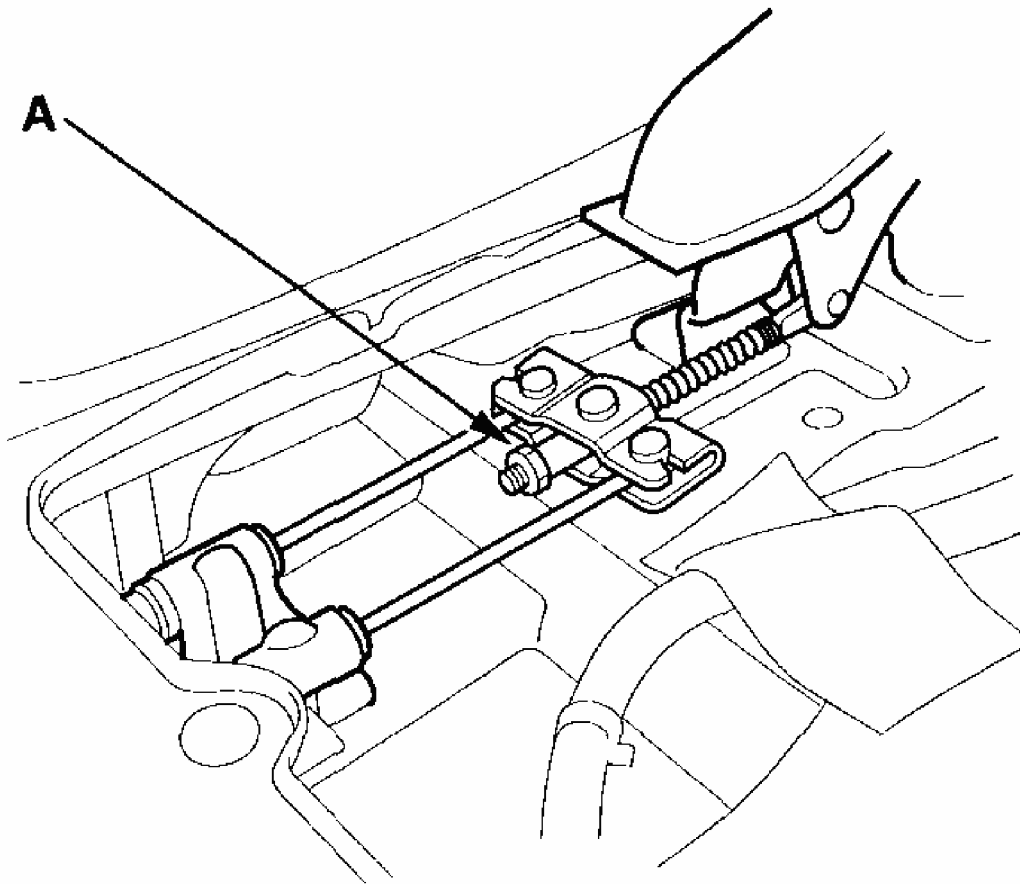

G03679155

Fig. 9: Tightening Adjusting Nut Until Parking Brakes Drag Slightly When Rear Wheels Turned

Courtesy of AMERICAN HONDA MOTOR CO., INC.

6. Release the parking brake lever fully, and check that the parking brakes do not drag when the rear wheels are turned. Readjust if necessary.
7. Make sure the parking brakes are fully applied when the parking brake lever is pulled all the way.
8. Install the center console (see **CENTER CONSOLE REMOVAL/INSTALLATION**).

MAJOR ADJUSTMENT (TO BE DONE WHEN REPLACING PARKING BRAKE SHOES AND AFTER LINING SURFACE BREAK-IN)

1. Raise the rear of the vehicle, and support it with safety stands in the proper locations (see **SAFETY STANDS**).

2. Release the parking brake lever fully.
3. Remove the center console (see **CENTER CONSOLE REMOVAL/INSTALLATION**).
4. Back off the adjusting nut (A) in the equalizer.

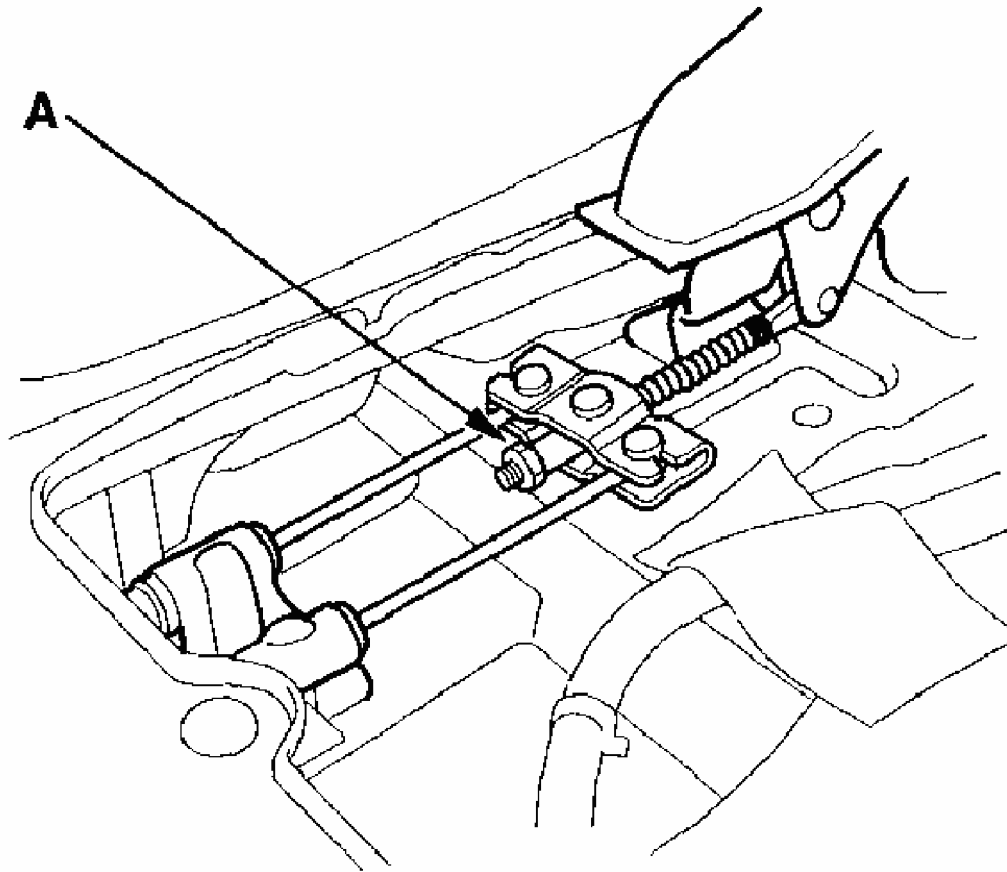

G03679156

Fig. 10: Identifying Adjusting Nut
Courtesy of AMERICAN HONDA MOTOR CO., INC.

5. Remove the rear wheels.
6. Remove the access plug (A).

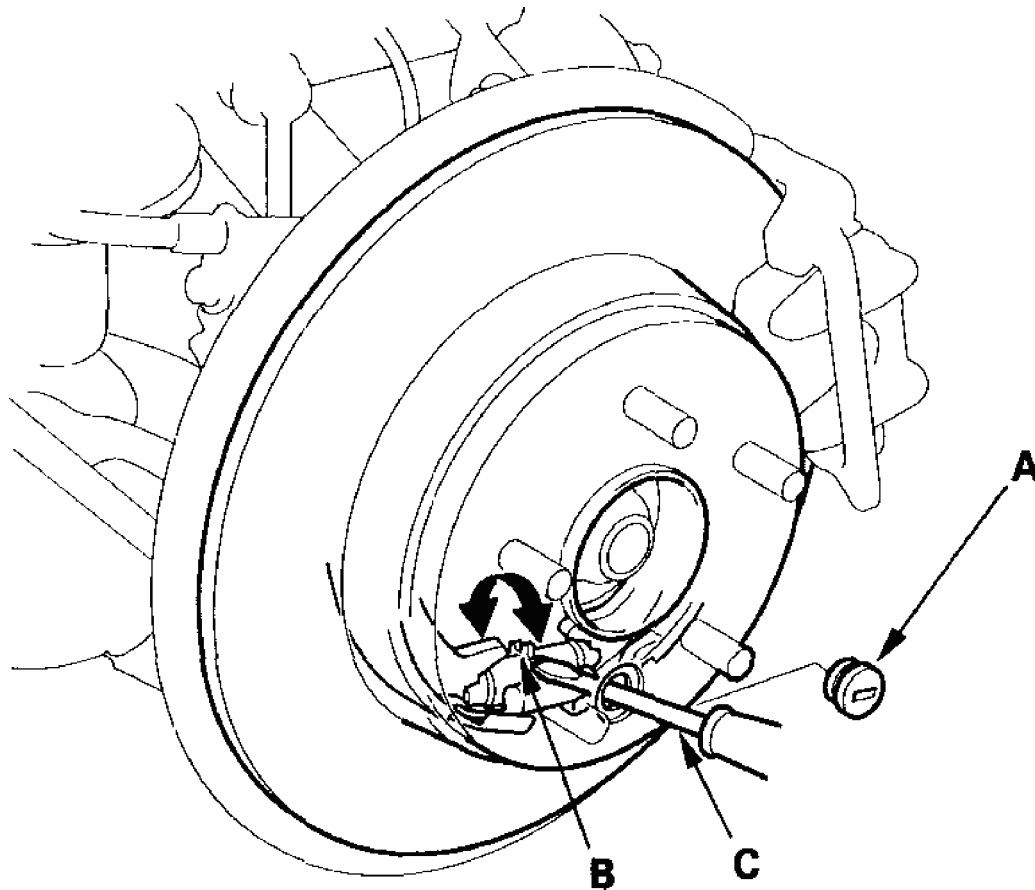

G03679157

Fig. 11: Removing Access Plug

Courtesy of AMERICAN HONDA MOTOR CO., INC.

7. Turn the adjuster (B) with a flat-tip screwdriver (C) until the shoes lock against the drum. Then back off 8 clicks, and install the access plug.
8. Do the minor adjustment procedure.
9. Install the rear wheels.
10. Install the center console (see CENTER CONSOLE REMOVAL/INSTALLATION).

BRAKE SYSTEM BLEEDING

NOTE:

- Do not reuse the drained fluid. Use only clean Honda DOT 3 Brake Fluid from an unopened container.

Using a non-Honda brake fluid can cause corrosion and shorten the life of the system.

- Do not mix different brands of brake fluid; they may not be compatible.
- Make sure no dirt or other foreign matter is allowed to contaminate the brake fluid.
- Do not spill brake fluid on the vehicle, it may damage the paint; if brake fluid does contact the paint, wash it off immediately with water.
- The reservoir on the master cylinder must be at the MAX (upper) level mark at the start of the bleeding procedure and checked after bleeding each brake caliper. Add fluid as required.

1. Make sure the brake fluid level in the reservoir is at the MAX (upper) level line (A).

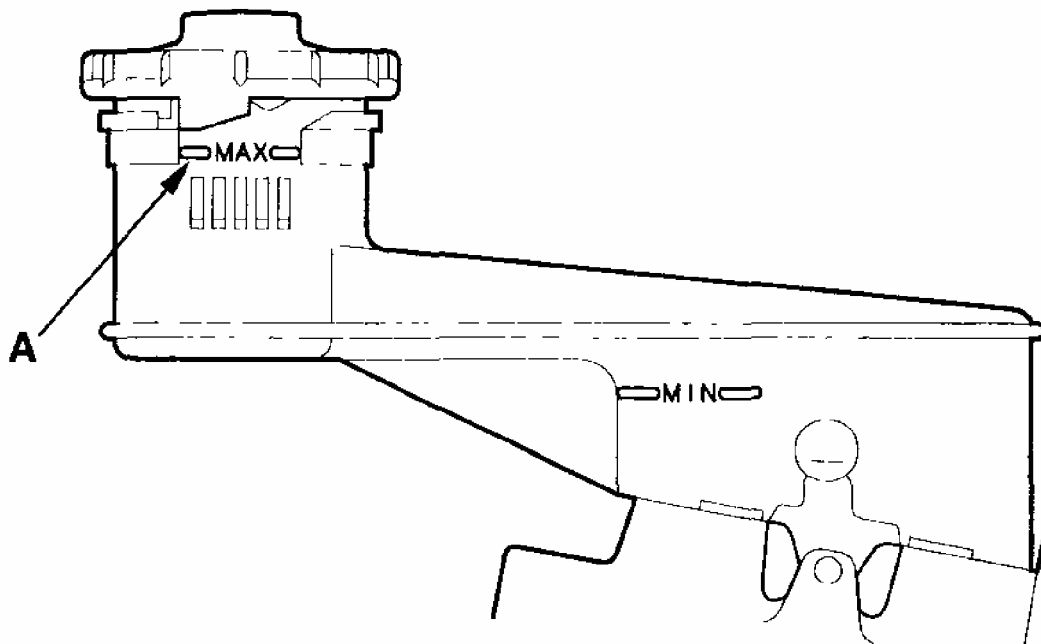

G03679158

Fig. 12: Identifying MAX (Upper) Level Line
Courtesy of AMERICAN HONDA MOTOR CO., INC.

2. Slide a piece of clear plastic hose over the bleed screw, and submerge the other end in a container of new brake fluid.

3. Have someone slowly pump the brake pedal several times, then apply steady pressure.
4. Loosen the left-front brake bleed screw to allow air to escape from the system. Then tighten the bleed screw securely.
5. Repeat the procedure for each caliper until no air bubbles are in the fluid. Bleed the calipers in the sequence shown.

BLEEDING SEQUENCE:

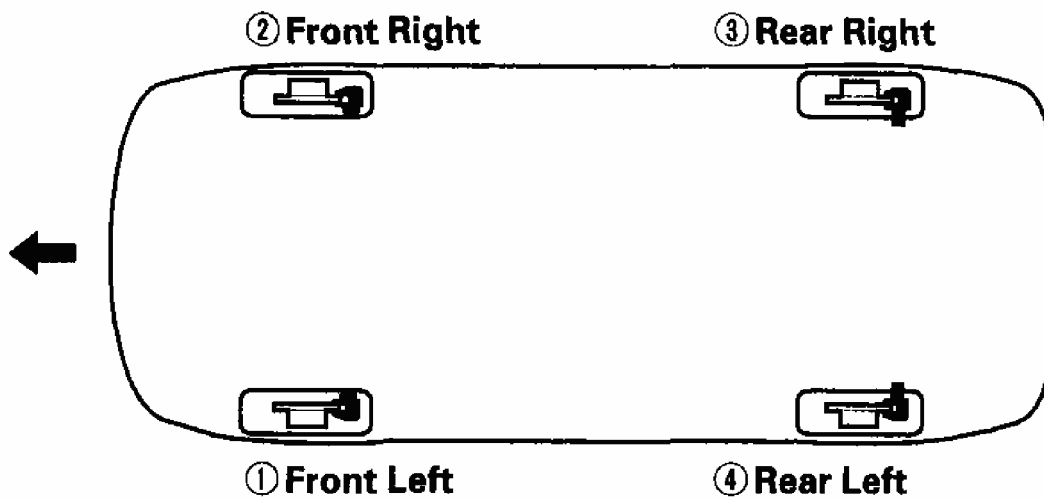

G03679159

Fig. 13: Identifying Bleeding Sequence
Courtesy of AMERICAN HONDA MOTOR CO., INC.

Front

8 N·m (0.8 kgf·m, 6 lbf·ft)

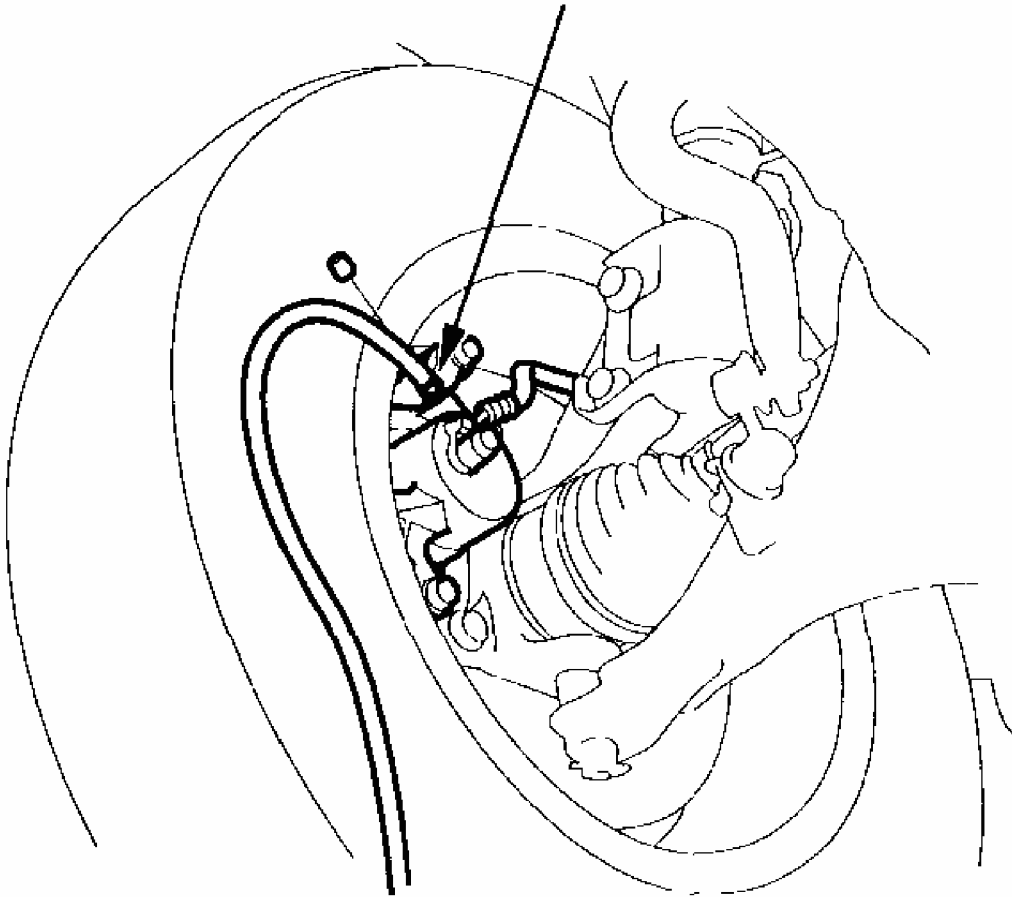

G03679160

Fig. 14: Identifying Bleeding Caliper And Torque Specifications (Front)
Courtesy of AMERICAN HONDA MOTOR CO., INC.

Rear

8 N·m (0.8 kgf·m, 6 lbf·ft)

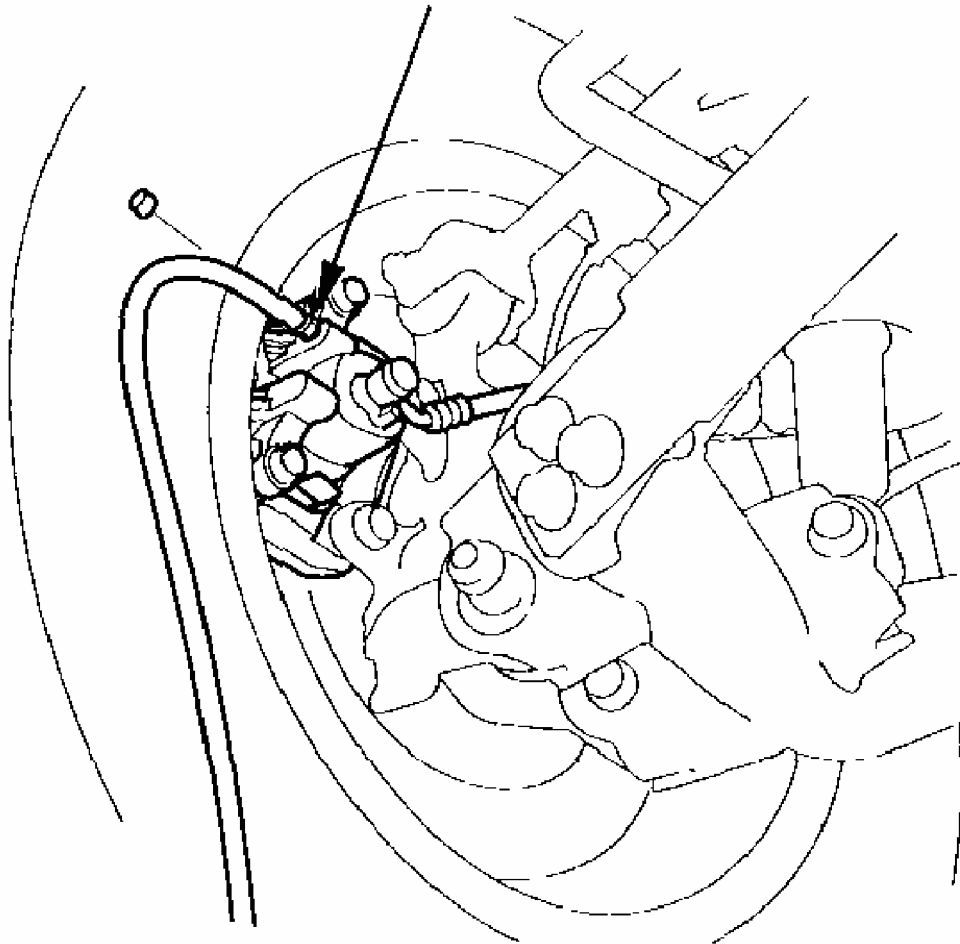

G03679161

Fig. 15: Identifying Bleeding Caliper And Torque Specifications (Rear)
Courtesy of AMERICAN HONDA MOTOR CO., INC.

6. Refill the master cylinder reservoir to the MAX (upper) level line.

BRAKE SYSTEM INDICATOR CIRCUIT DIAGRAM

2004 Honda Element DX

2003-06 BRAKES Conventional Brake Components - Element

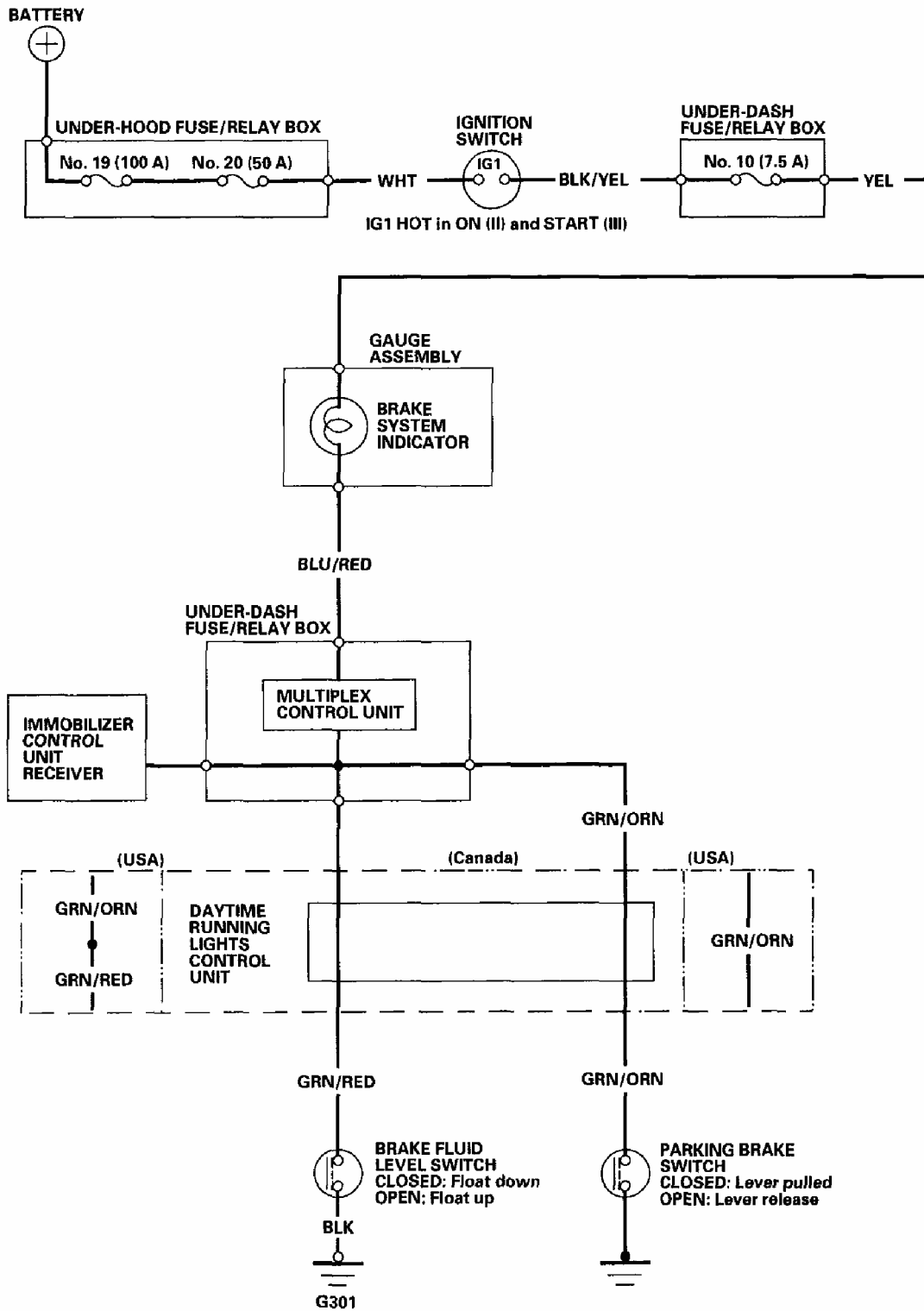

G03679162

Fig. 16: Identifying Brake System Indicator Circuit Diagram
Courtesy of AMERICAN HONDA MOTOR CO., INC.

PARKING BRAKE SWITCH TEST

1. Remove the center console (see **CENTER CONSOLE REMOVAL/INSTALLATION**).
2. Disconnect the connector from the parking brake switch (A).

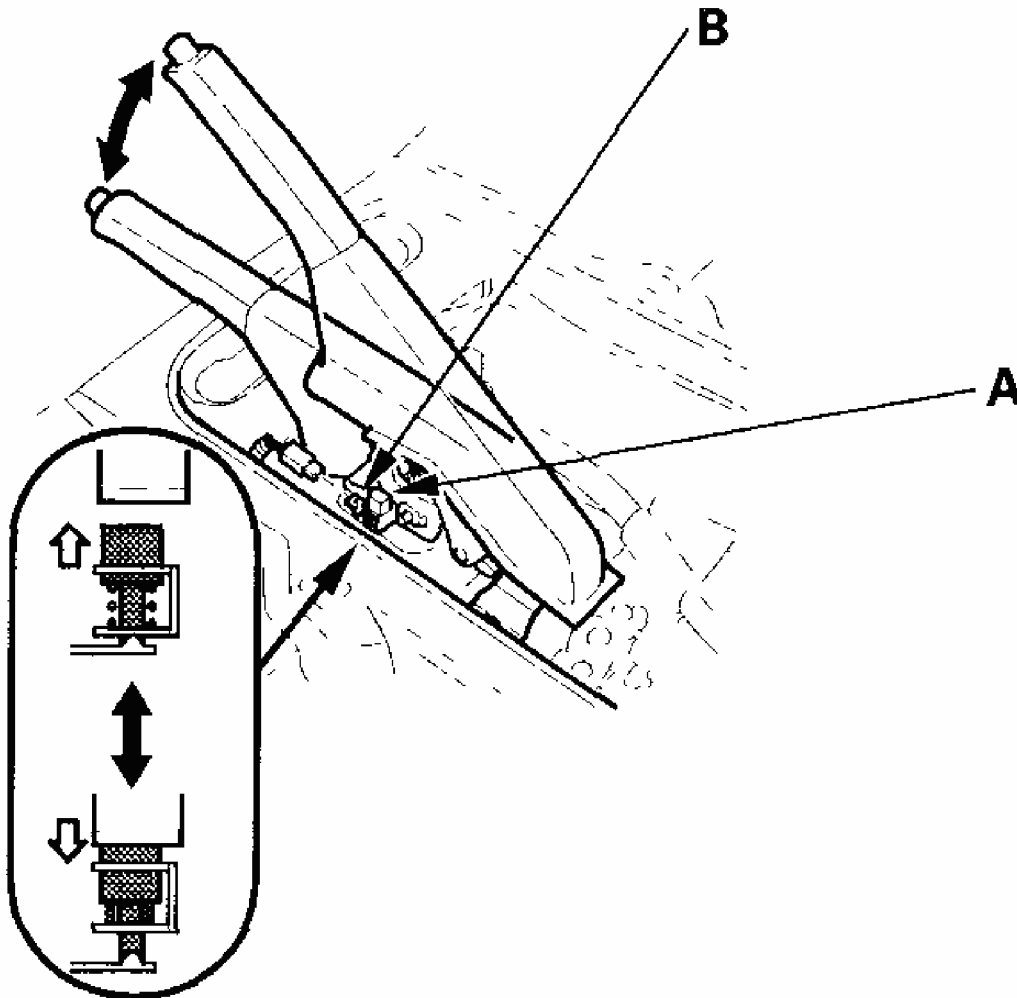

G03679163

Fig. 17: Disconnecting Connector From Parking Brake Switch
Courtesy of AMERICAN HONDA MOTOR CO., INC.

3. Check for continuity between the switch terminal (B) and body ground.
 - With the parking brake lever pulled, there should be continuity.
 - With the parking brake lever released, there should be no continuity.

NOTE:

- If both the ABS indicator and the brake system indicator come on at the same time, check the ABS (see ABS INDICATOR).
- If the parking brake switch and brake fluid level switch are OK, but the brake system indicator does not work, check the ABS (see ABS INDICATOR).

BRAKE FLUID LEVEL SWITCH TEST

Check for continuity between the terminals (A) with the float in the down position and the up position.

- Remove the brake fluid completely from the reservoir. With the float down, there should be continuity.
- Fill the reservoir with brake fluid to the MAX (upper) level (B). With the float up, there should be no continuity.

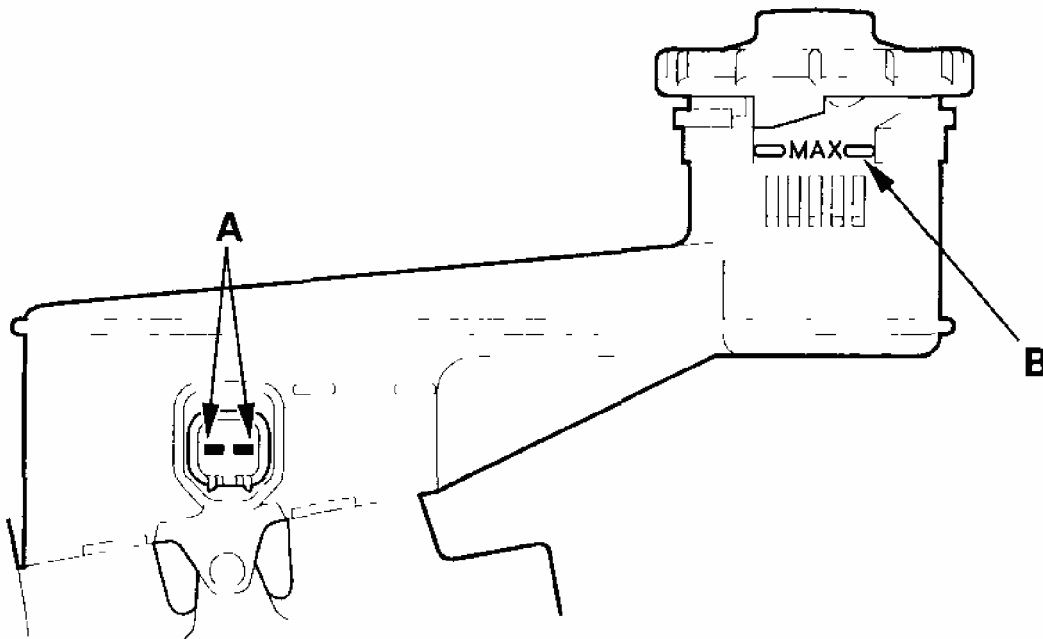

G03679164

Fig. 18: Identifying Brake Fluid Level Switch Terminals
Courtesy of AMERICAN HONDA MOTOR CO., INC.

FRONT BRAKE PAD INSPECTION AND REPLACEMENT

CAUTION: Frequent inhalation of brake pad dust, regardless of material composition, could be hazardous to your health.

- **Avoid breathing dust particles.**
- **Never use an air hose or brush to clean brake assemblies. Use an OSHA-approved vacuum cleaner.**

INSPECTION

1. Raise the front of the vehicle, and support it with safety stands in the proper locations (see **SAFETY STANDS**).
2. Remove the front wheels.
3. Check the thickness of the inner pad (A) and outer pad (B). Do not include the thickness of the brake pad backing plate.

Brake pad thickness:

Standard: 10.6-11.2 mm (0.42-0.44 in.)

Service limit: 1.6 mm (0.06 in.)

Inner pad

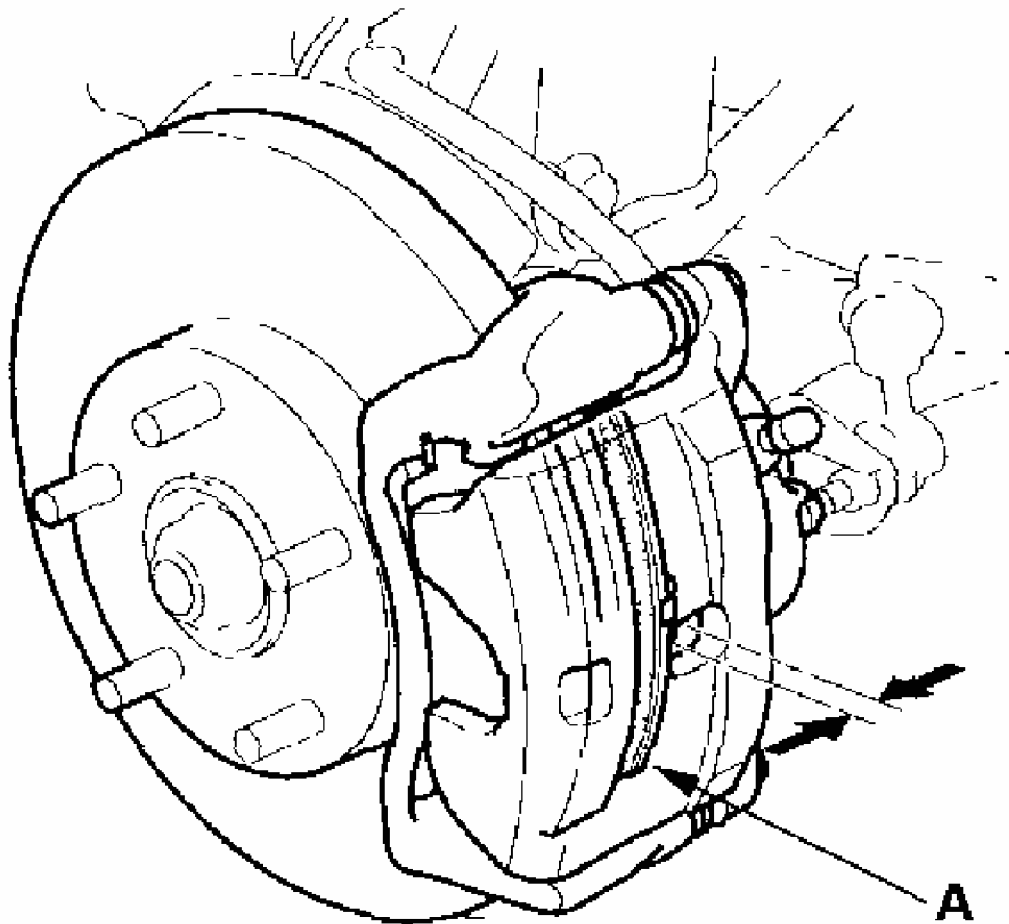

G03679165

Fig. 19: Identifying Brake Inner Pad
Courtesy of AMERICAN HONDA MOTOR CO., INC.

Outer pad

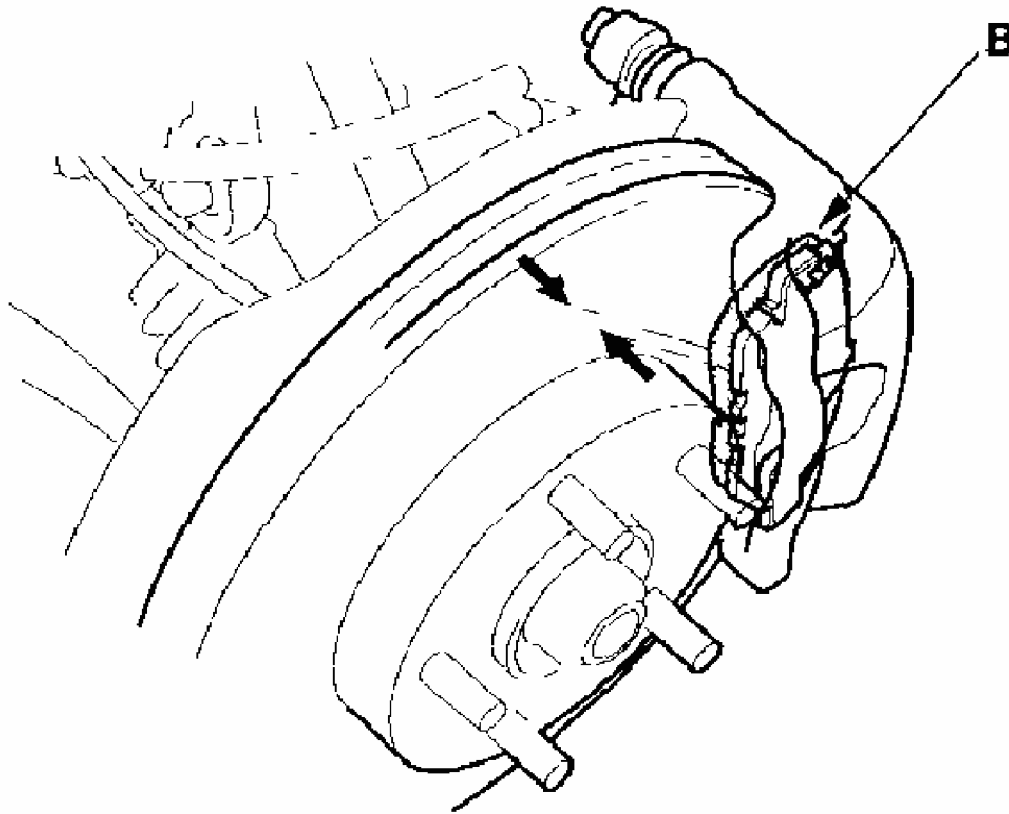

G03679166

Fig. 20: Identifying Brake Outer Pad

Courtesy of AMERICAN HONDA MOTOR CO., INC.

4. If the brake pad thickness is less than the service limit, replace all the pads as a set.

REPLACEMENT

1. Remove the flange bolt (A).

NOTE: The pad springs are installed on the brake pads to prevent brake drag. Be careful when pivoting up the caliper body fully, or the spring could be flipped out of position.

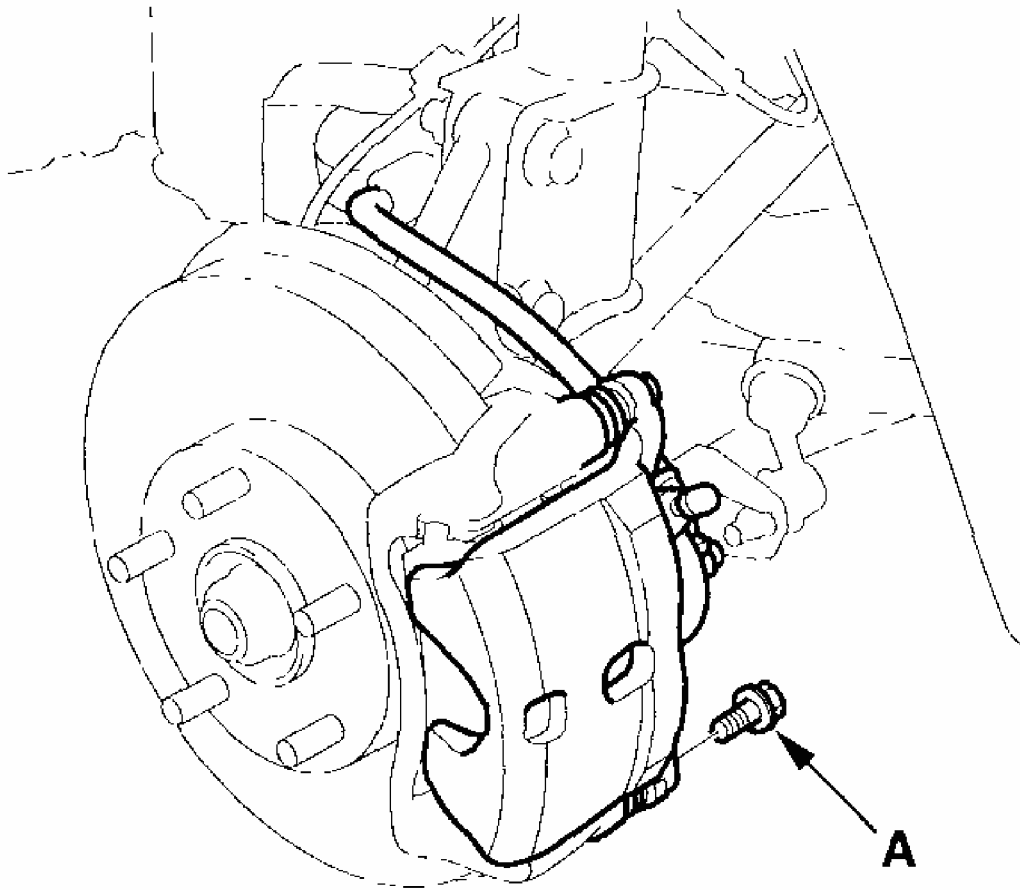

G03679167

Fig. 21: Removing Flange Bolt

Courtesy of AMERICAN HONDA MOTOR CO., INC.

2. Pivot the caliper slightly so the brake pads do not come out of position, and hold the brake pads on both sides firmly with your fingers. Remove the pad springs (A) from the brake pads.

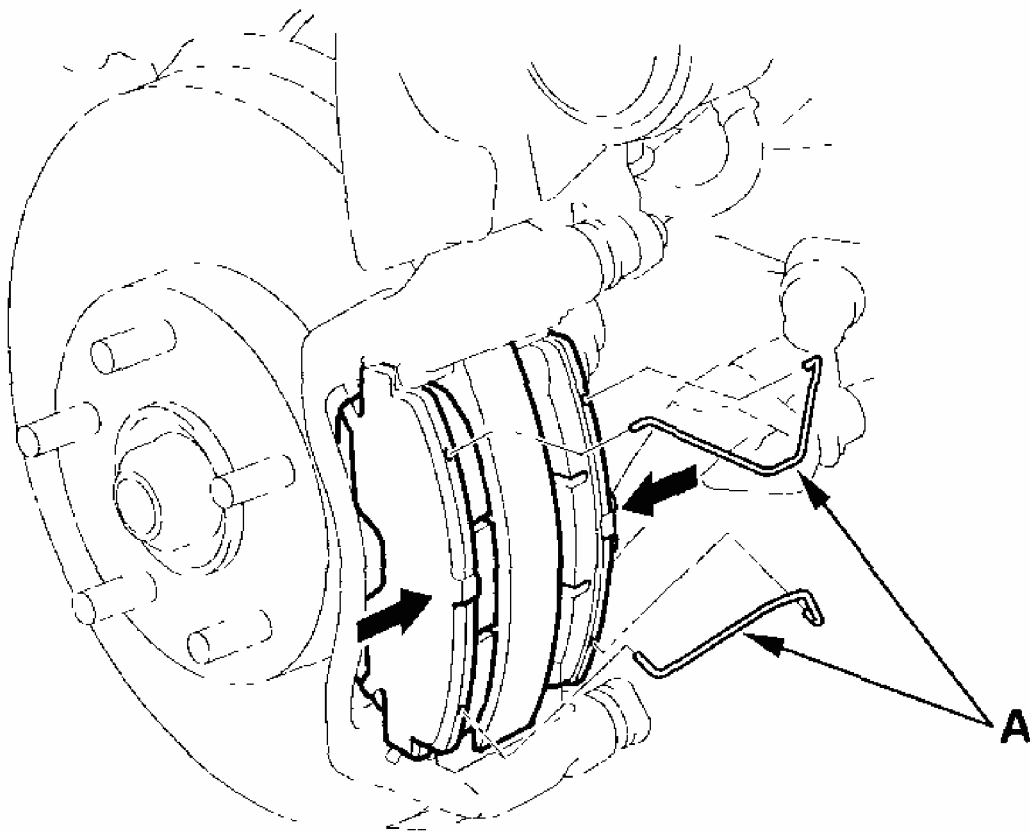

G03679168

Fig. 22: Removing Pad Springs

Courtesy of AMERICAN HONDA MOTOR CO., INC.

3. Pivot the caliper up out of the way, and remove the pads (A).

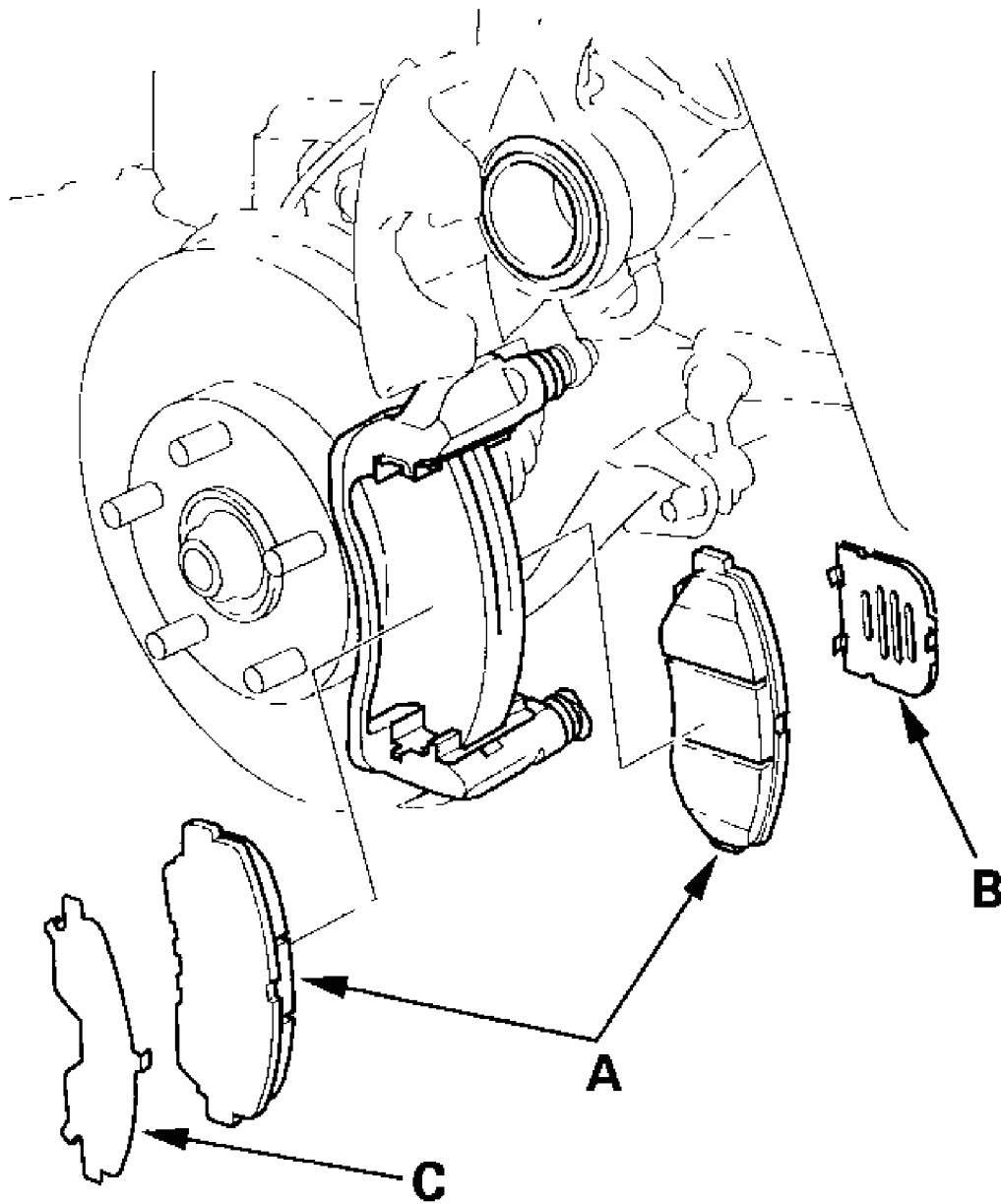

G03679169

Fig. 23: Pivoting Caliper Up Out Of Way And Removing The Pads
Courtesy of AMERICAN HONDA MOTOR CO., INC.

4. Remove the inner pad shim (B), and outer pad shim (C).
5. Check the hose and pin boots for damage and deterioration.
6. Remove the pad retainers (A). Clean the upper and lower pad retainers; remove any corrosion.

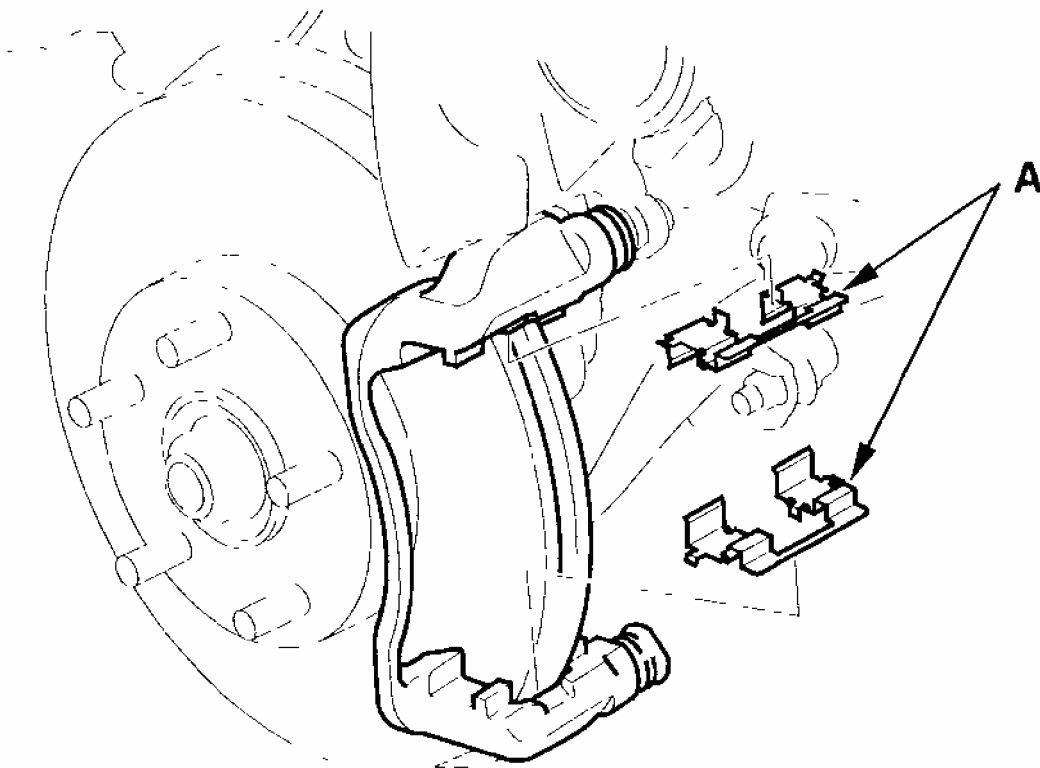

G03679170

Fig. 24: Removing Inner Pad Shim And Outer Pad Shim
Courtesy of AMERICAN HONDA MOTOR CO., INC.

7. Clean the caliper thoroughly; remove any rust, and check for grooves and cracks.
8. Check the brake disc for damage and cracks.
9. Install the pad retainers.
10. Apply a thin coat of M-77 assembly paste (P/N 08798-9010) to both sides of the inner pad shim (A), and outer pad shim (B), the back of the brake pads (C), and the other areas indicated by the arrows. Wipe excess assembly paste off the shim. Contaminated brake discs and brake pads reduce stopping ability. Keep assembly paste off the brake discs and brake pad material.

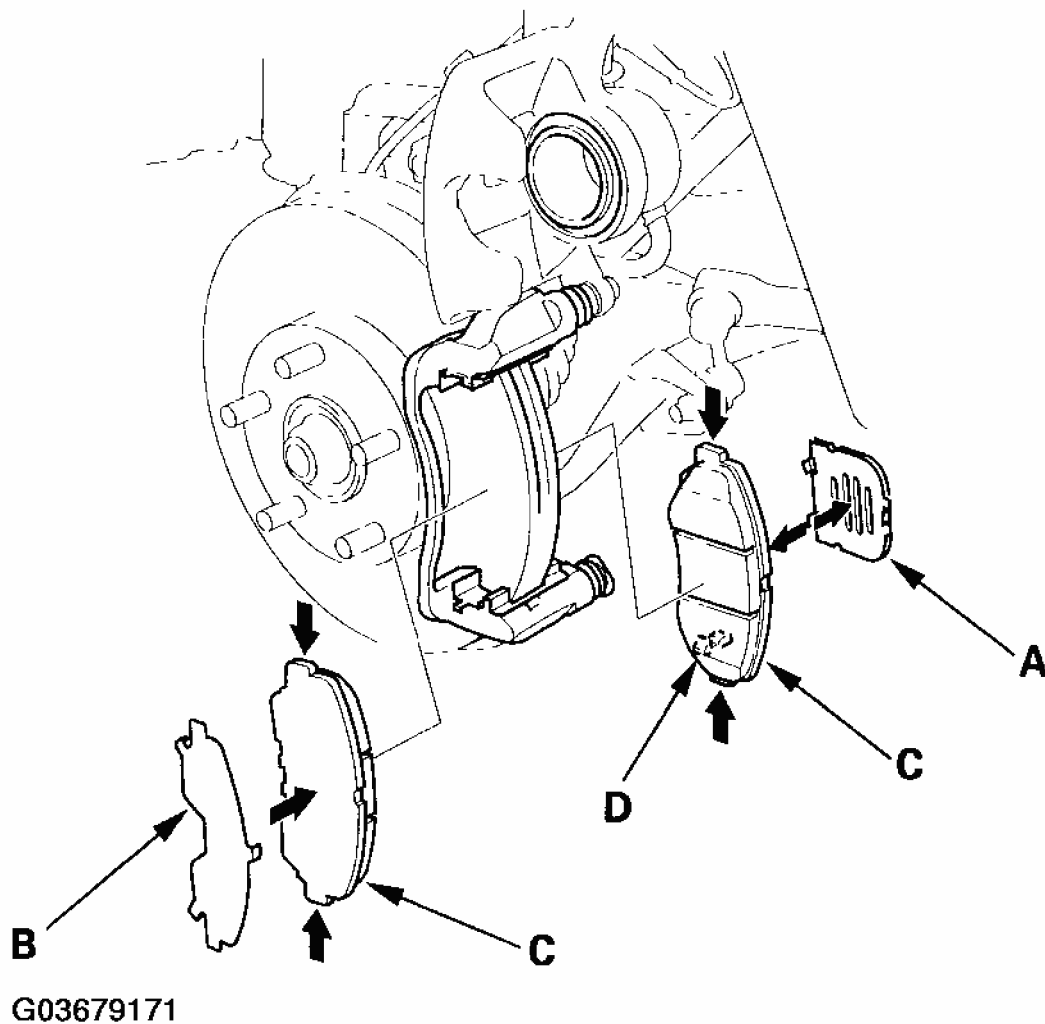
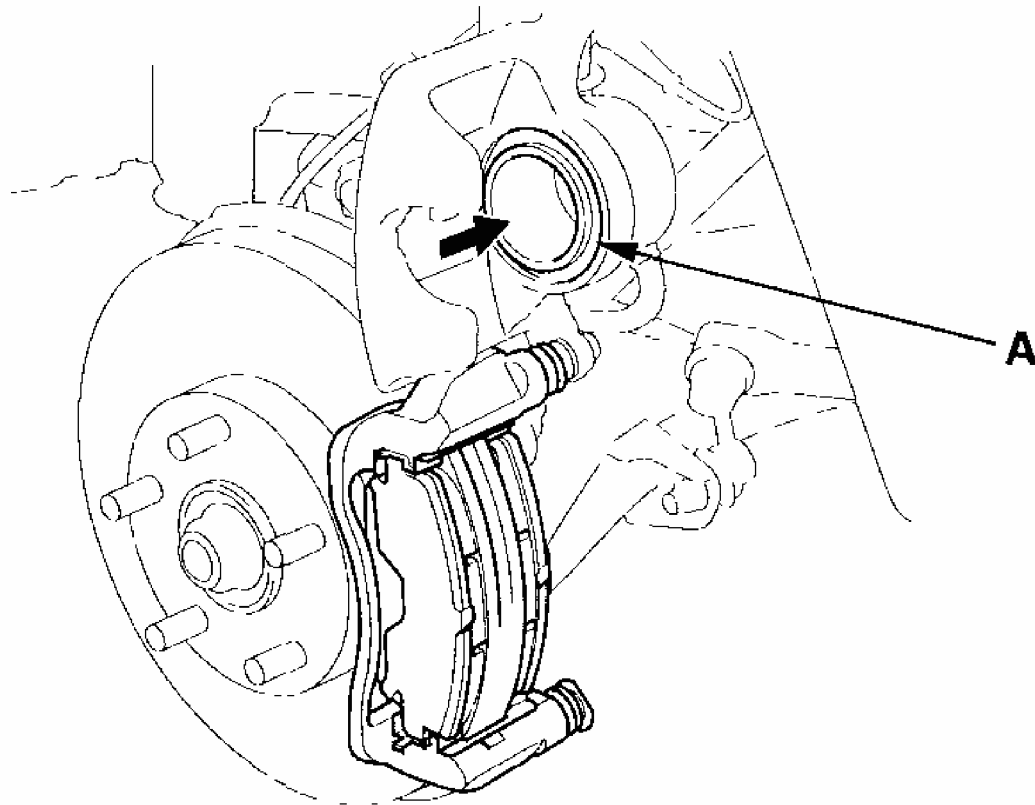

Fig. 25: Applying A Coat Of M-77 Assembly
 Courtesy of AMERICAN HONDA MOTOR CO., INC.

11. Install the brake pads and pad shims correctly. Install the brake pads with the wear indicator (D) on the bottom inside.

If you are reusing the brake pads, always reinstall the brake pads in their original positions to prevent a momentary loss of braking efficiency.

12. Push in the piston (A) so the caliper will fit over the brake pads. Check the brake fluid level. The brake fluid may overflow if the reservoir is too full. Make sure the piston boot is in position to prevent damaging it when pivoting the caliper down.



G03679172

Fig. 26: Pushing Piston For Caliper To Fit Over Brake Pads
Courtesy of AMERICAN HONDA MOTOR CO., INC.

13. Hold the brake pads on both sides firmly with your fingers, and install the new pad springs (A) on the brake pads. Holding the brake pads, set the caliper over the brake pads by pivoting it down slowly.

NOTE: Insert the pad spring ends into the pad installation holes securely.

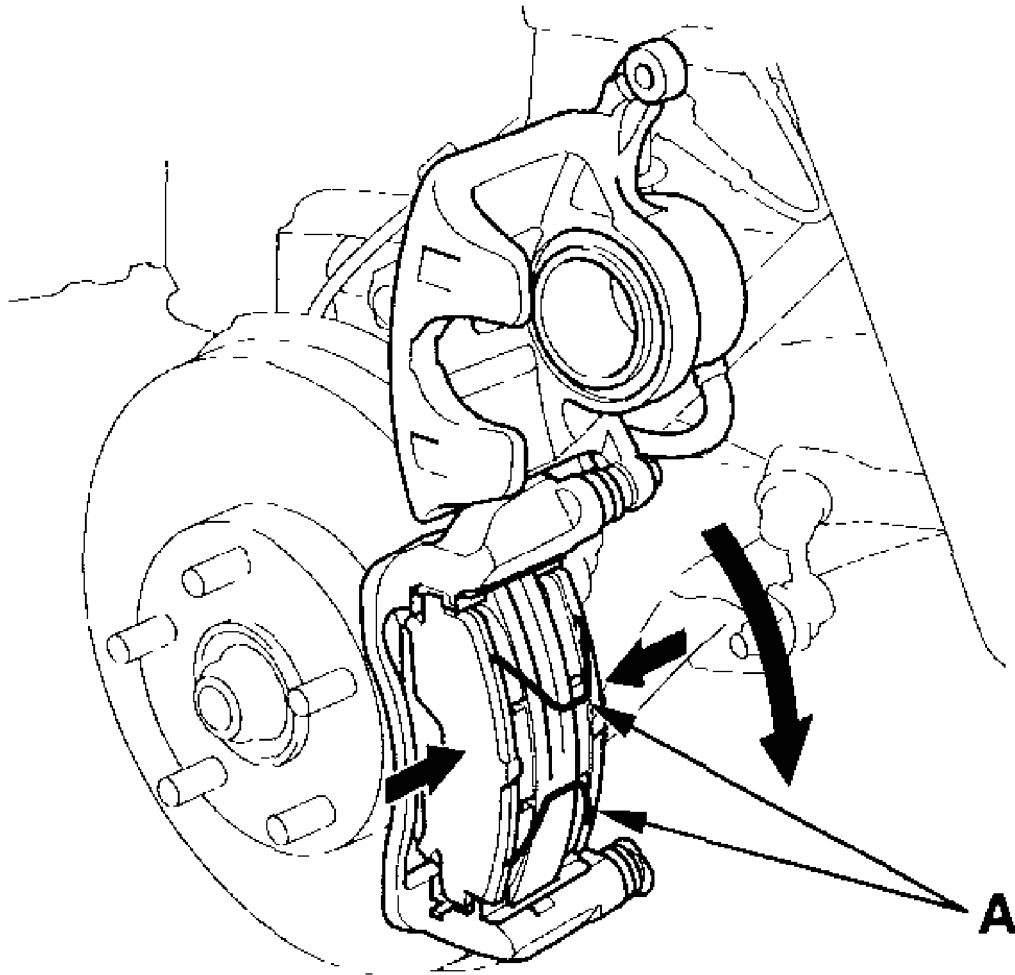

G03679173

Fig. 27: Inserting Pad Spring Ends Into Pad
Courtesy of AMERICAN HONDA MOTOR CO., INC.

14. Pivot the caliper (A) down into position. Be careful not to damage the pin boots.

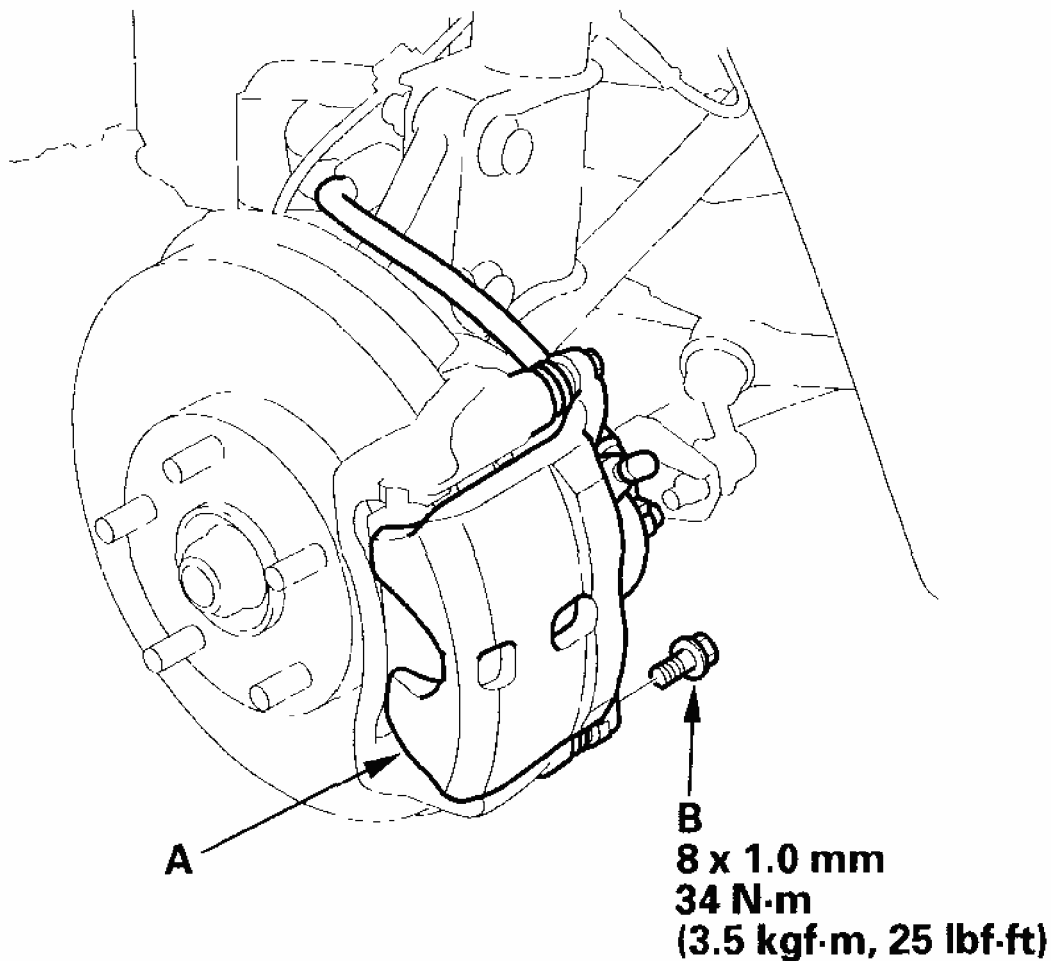

G03679174

Fig. 28: Pivoting Caliper Down Into Position And Torque Specifications
Courtesy of AMERICAN HONDA MOTOR CO., INC.

15. Install the flange bolt (B), and tighten it to the specified torque.
16. Press the brake pedal several times to seat the pads/pistons and restore brake pedal height.
17. After installation, check for leaks at the hose and line joints or connections, and retighten if necessary.
18. Install the front wheels, and test-drive the vehicle.

FRONT BRAKE DISC INSPECTION

RUNOUT

1. Raise the front of the vehicle, and support it with safety stands in the proper locations

(see **SAFETY STANDS**).

2. Remove the front wheels.
3. Remove the brake pads (see **FRONT BRAKE PAD INSPECTION AND REPLACEMENT**).
4. Inspect the disc surface for damage and cracks. Clean the disc thoroughly, and remove all rust.
5. Install suitable flat washers (A) and wheel nuts (B), and tighten the nuts to the specified torque to hold the brake disc securely against the hub.

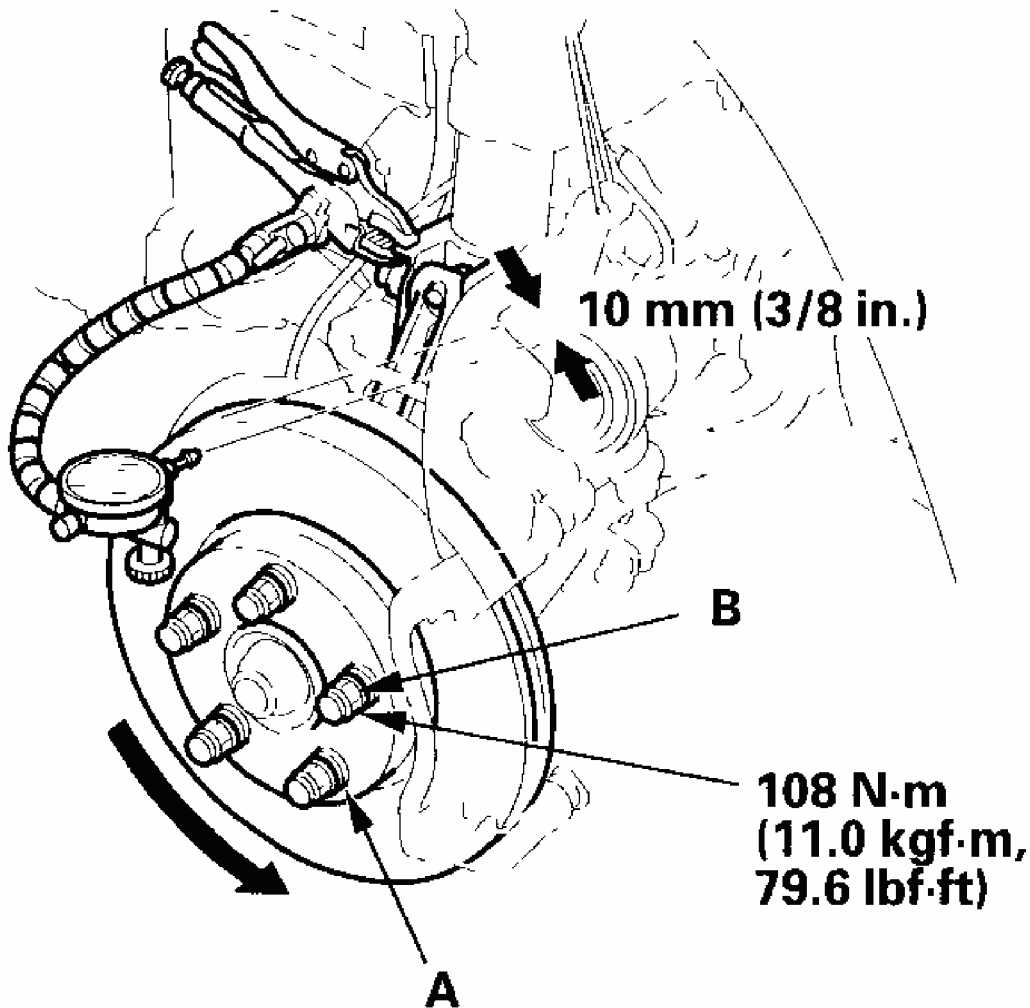

G03679175

Fig. 29: Installing Suitable Flat Washers And Wheel Nuts With Torque Specifications

Courtesy of AMERICAN HONDA MOTOR CO., INC.

6. Set up the dial gauge against the brake disc as shown, and measure the runout at 10 mm (3/8 in.) from the outer edge of the disc.

Brake disc runout:

Service limit: 0.10 mm (0.004 in.)

7. If the disc is beyond the service limit, refinish the brake disc.

Max. refinishing limit: 21.0 mm (0.83 in.)

NOTE:

- If the brake disc is beyond the service limit for refinishing, replace it (see step 3 on KNUCKLE AND HUB REPLACEMENT).
- A new disc should be refinished if its runout is greater than 0.10 mm (0.004 in.).

THICKNESS AND PARALLELISM

1. Raise the front of the vehicle, and support it with safety stands in the proper locations (see SAFETY STANDS).
2. Remove the front wheels.
3. Remove the brake pads (see)FRONT BRAKE PAD INSPECTION AND REPLACEMENT).
4. Using a micrometer, measure disc thickness at eight points, approximately 45° apart and 10 mm (3/8 in.) in from the outer edge of the disc.

Brake disc thickness:

Standard: 23.0 mm (0.91 in.)

Max. refinishing limit: 21.0 mm (0.83 in.)

Brake disc parallelism: 0.015 mm (0.0006 in.) max.

NOTE:

Parallelism is the maximum allowable difference between the thickness measurements.

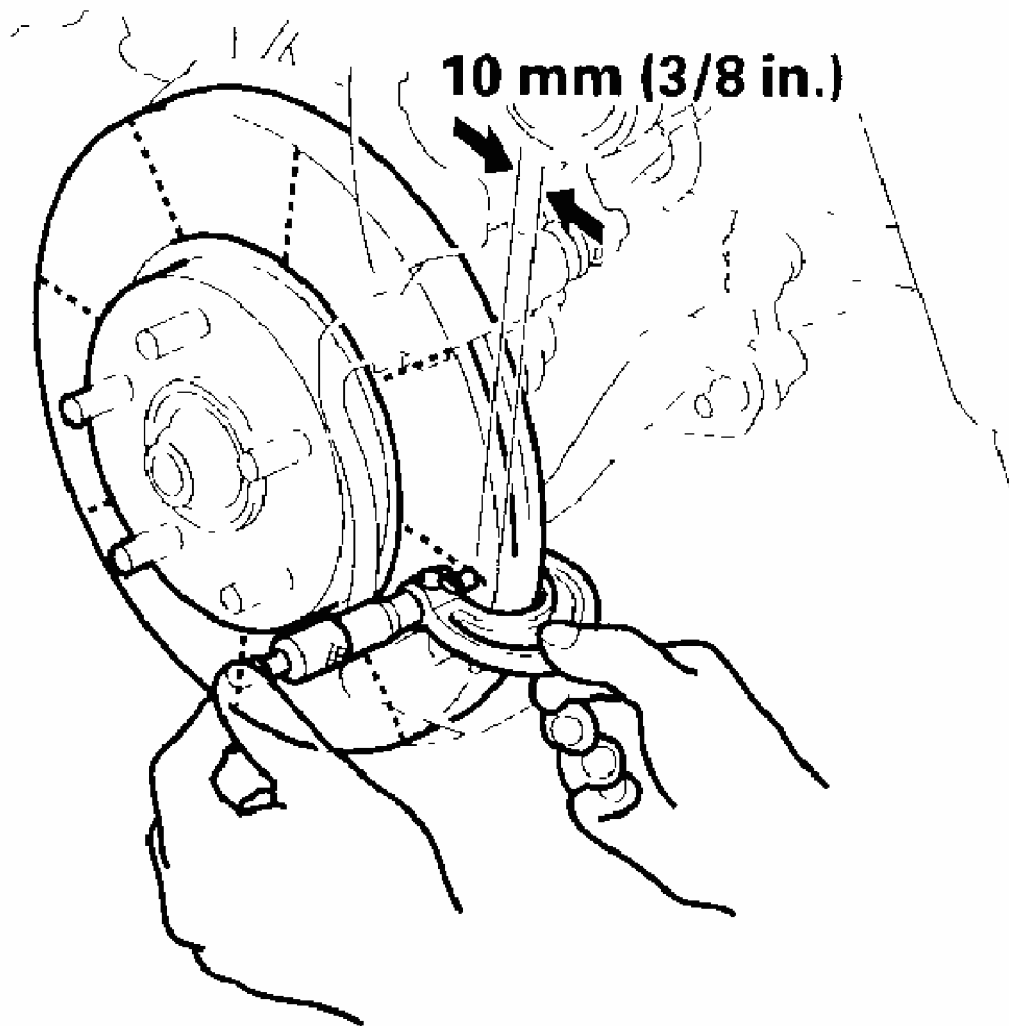

G03679176

Fig. 30: Parallelism Maximum Allowable Difference Between Thickness
Courtesy of AMERICAN HONDA MOTOR CO., INC.

5. If the disc is beyond the service limit for parallelism, refinish the brake disc with an on-car brake lathe. The Kwik-Lathe produced by Kwik-Way Manufacturing Co. and the "Front Brake Disc Lathe" offered by Snap-on Tools Co. are approved for this operation.

NOTE: If the brake disc is beyond the service limit for refinishing, replace it (see step 3 on KNUCKLE AND HUB REPLACEMENT).

FRONT BRAKE CALIPER OVERHAUL

CAUTION: Frequent inhalation of brake pad dust, regardless of material composition, could be hazardous to your health.

- Avoid breathing dust particles.
- Never use an air hose or brush to clean brake assemblies. Use an OSHA-approved vacuum cleaner.

Remove, disassemble, inspect, reassemble, and install the caliper, and note these items:

NOTE: Make sure that the caliper pins are installed correctly. The upper and lower caliper pins are different. If the caliper pins are installed in the wrong location, it will cause uneven tire wear, vibration, and/or uneven or rapid pad wear.

- Do not spill brake fluid on the vehicle; it may damage the paint; if brake fluid gets on the paint, wash it off immediately with water.
- To prevent dripping brake fluid, cover disconnected hose joints with rags or shop towels.
- Clean all parts in brake fluid and air dry; blow out all passages with compressed air.
- Before reassembling, check that all parts are free of dust and other foreign particles.
- Replace parts with new ones as specified in the illustration.
- Make sure no dirt or other foreign matter is allowed to contaminate the brake fluid.
- When reusing brake pads, always reinstall them in their original positions to prevent loss of braking efficiency.
- Do not reuse drained brake fluid.
- Always use Honda DOT 3 Brake Fluid from an unopened container. Using a non-Honda brake fluid can cause corrosion and shorten the life of the system.
- Do not mix different brands of brake fluid as they may not be compatible.
- Coat the piston, piston seal groove, and caliper bore with clean brake fluid.
- Make sure no grease or oil gets on the brake discs or pads.
- Replace all rubber parts with new ones whenever

disassembled.

- After installing the caliper, check the brake hose and line for leaks, interference, and twisting.

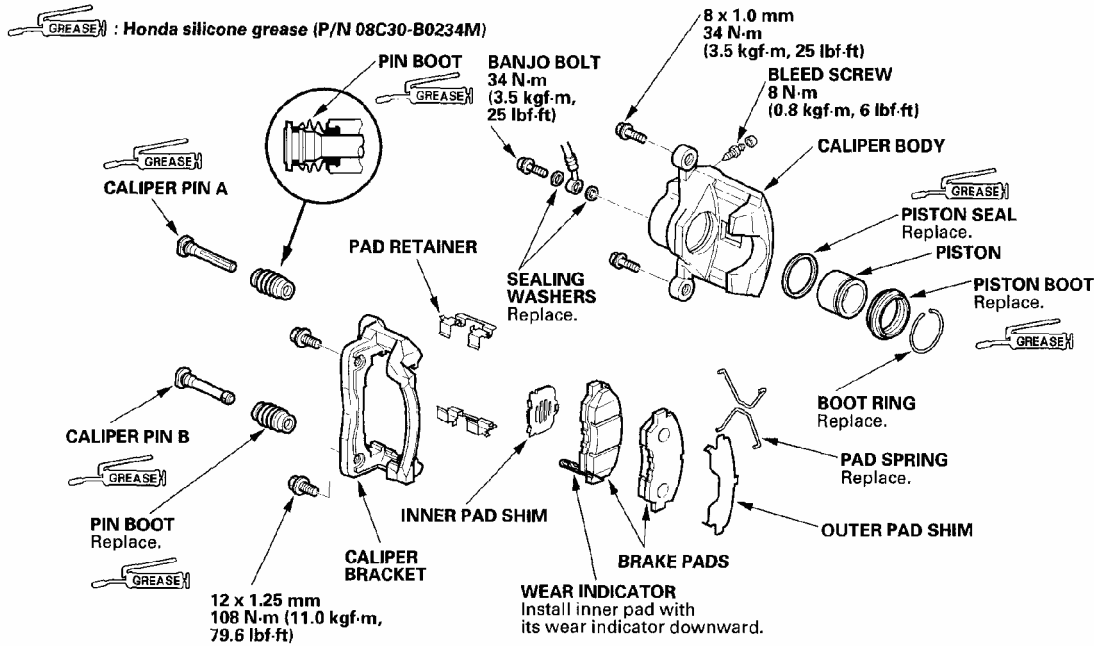

G03679177

Fig. 31: Exploded View Of Front Brake Caliper
 Courtesy of AMERICAN HONDA MOTOR CO., INC.

MASTER CYLINDER REPLACEMENT

NOTE: Do not spill brake fluid on the vehicle; it may damage the paint; if brake fluid does contact the paint, wash it off immediately with water.

1. Release the engine wire harness clips on the strut brace (A), and remove the strut brace. With M/T: Remove the clutch reservoir bracket from the vehicle, and move it aside. Do not disconnect the clutch hose from the reservoir.

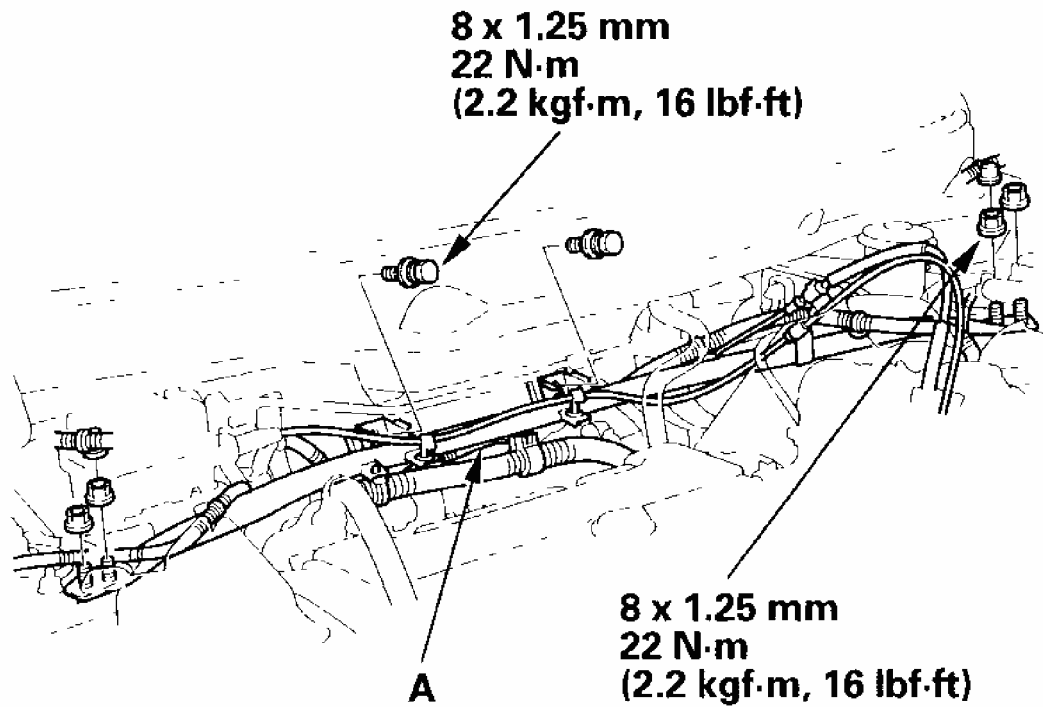

G03679178

Fig. 32: Removing Strut Brace

Courtesy of AMERICAN HONDA MOTOR CO., INC.

2. Remove the reservoir cap and brake fluid from the master cylinder reservoir.
3. Remove the brake fluid level sensor connector (A).

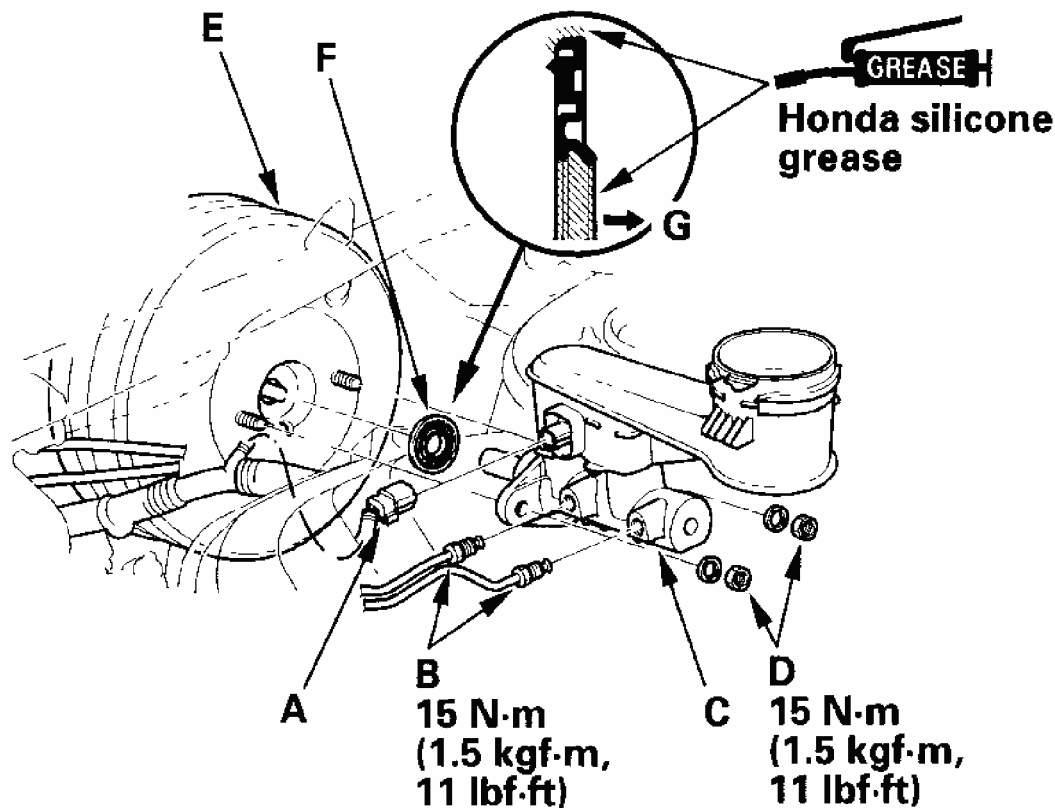

G03679179

Fig. 33: Removing Brake Fluid Level Sensor Connector And Torque Specifications

Courtesy of AMERICAN HONDA MOTOR CO., INC.

4. Disconnect the brake lines (B) from the master cylinder (C). To prevent spills, cover the hose joints with rags or shop towels.
5. Remove the master cylinder mounting nuts (D) and washers.
6. Remove the master cylinder from the brake booster (E). Be careful not to bend or damage the brake lines when removing the master cylinder.
7. Remove the rod seal (F) from the master cylinder.
8. Install the master cylinder in the reverse order of removal, and note these items:
 - Replace all the rubber parts with new ones whenever the master cylinder is removed.
 - Check the pushrod clearance before installing the master cylinder, and adjust it if necessary (see **MASTER CYLINDER INSPECTION**).
 - Use a new rod seal on reassembly.
 - Coat the inner bore lip and outer circumference of the new rod seal with the

recommended seal grease.

- Install the rod seal onto the master cylinder with its grooved side (G) toward the master cylinder.
- Check the brake pedal height and free play after installing the master cylinder, and adjust it if necessary (see) **BRAKE PEDAL AND BRAKE PEDAL POSITION SWITCH ADJUSTMENT** .
- Bleed the brake system (see) **BRAKE SYSTEM BLEEDING** .

9. Spin the wheels to check for brake drag.

MASTER CYLINDER INSPECTION

NOTE:

- **Before reassembling, check that all parts are free of dirt and other foreign particles.**
- **Do not try to disassemble the master cylinder assembly. Replace the master cylinder assembly with a new part if necessary.**
- **Do not allow dirt or foreign matter to contaminate the brake fluid.**

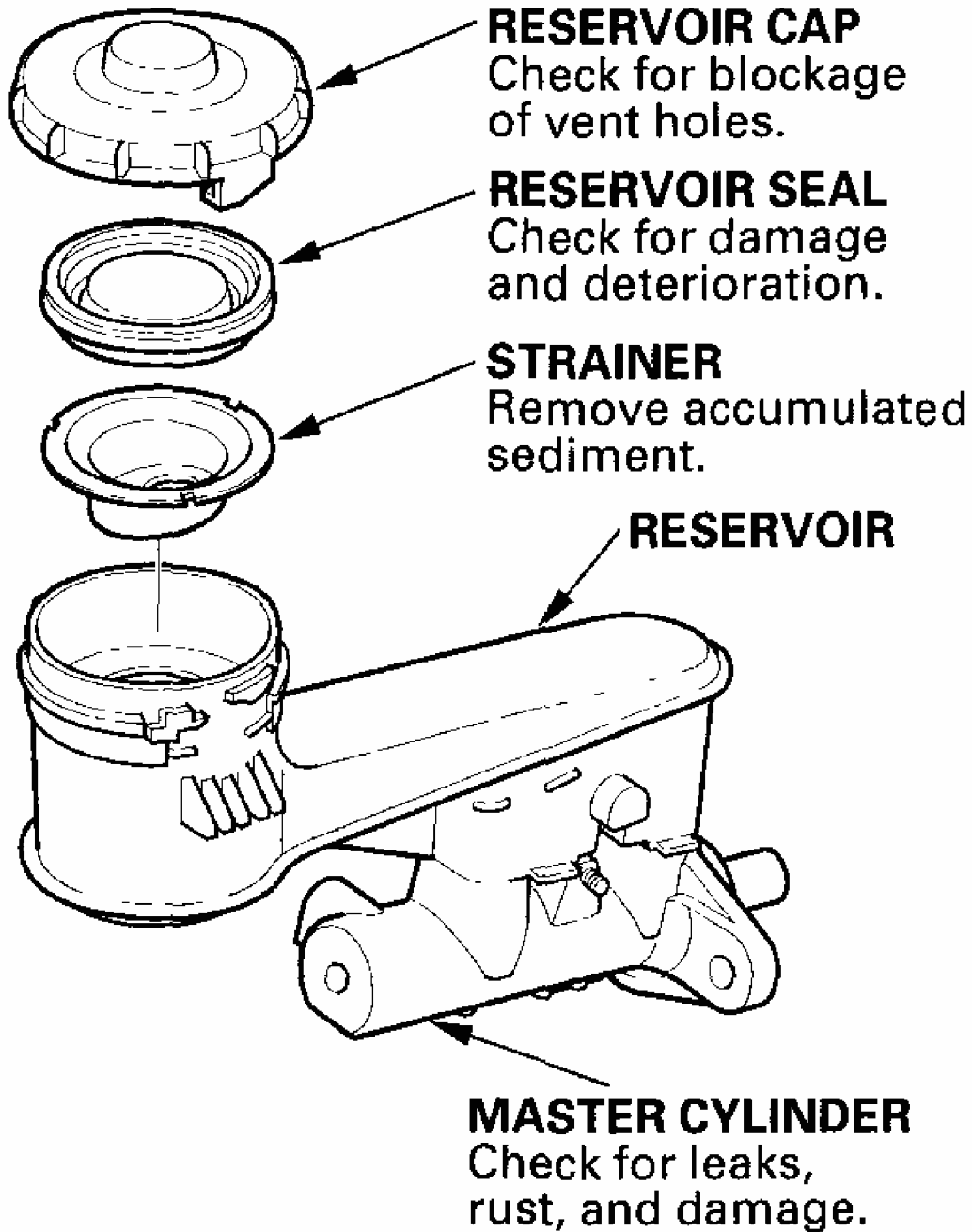

G03679180

Fig. 34: Identifying Master Cylinder
Courtesy of AMERICAN HONDA MOTOR CO., INC.

BRAKE BOOSTER PUSHROD CLEARANCE ADJUSTMENT

Special Tools Required

Pushrod adjustment gauge 07JAG-SD40100

NOTE: Brake booster pushrod-to-piston clearance must be checked and adjustments made, if necessary, before installing the master cylinder.

1. Set the special tool (A) on the master cylinder body (B), push in the center shaft (C) until the top of it contacts the end of the secondary piston (D) by turning the adjusting nut (E).

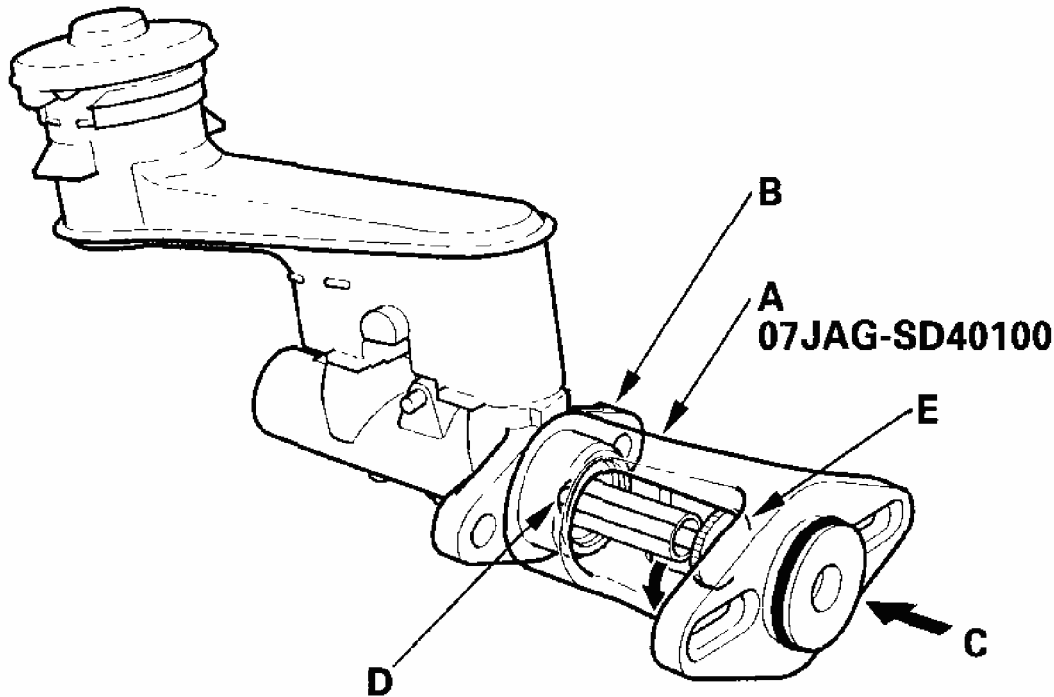

G03679181

Fig. 35: Identifying Special Tools
Courtesy of AMERICAN HONDA MOTOR CO., INC.

2. Without disturbing the center shaft's position, install the special tool (A) backwards on the booster.

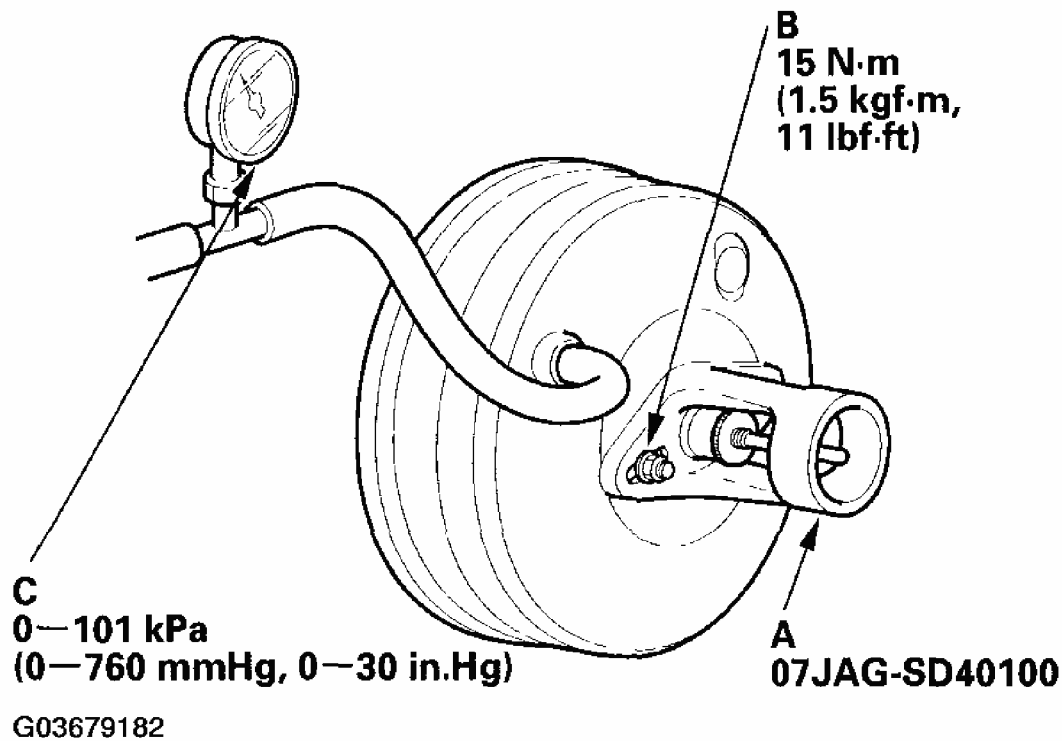
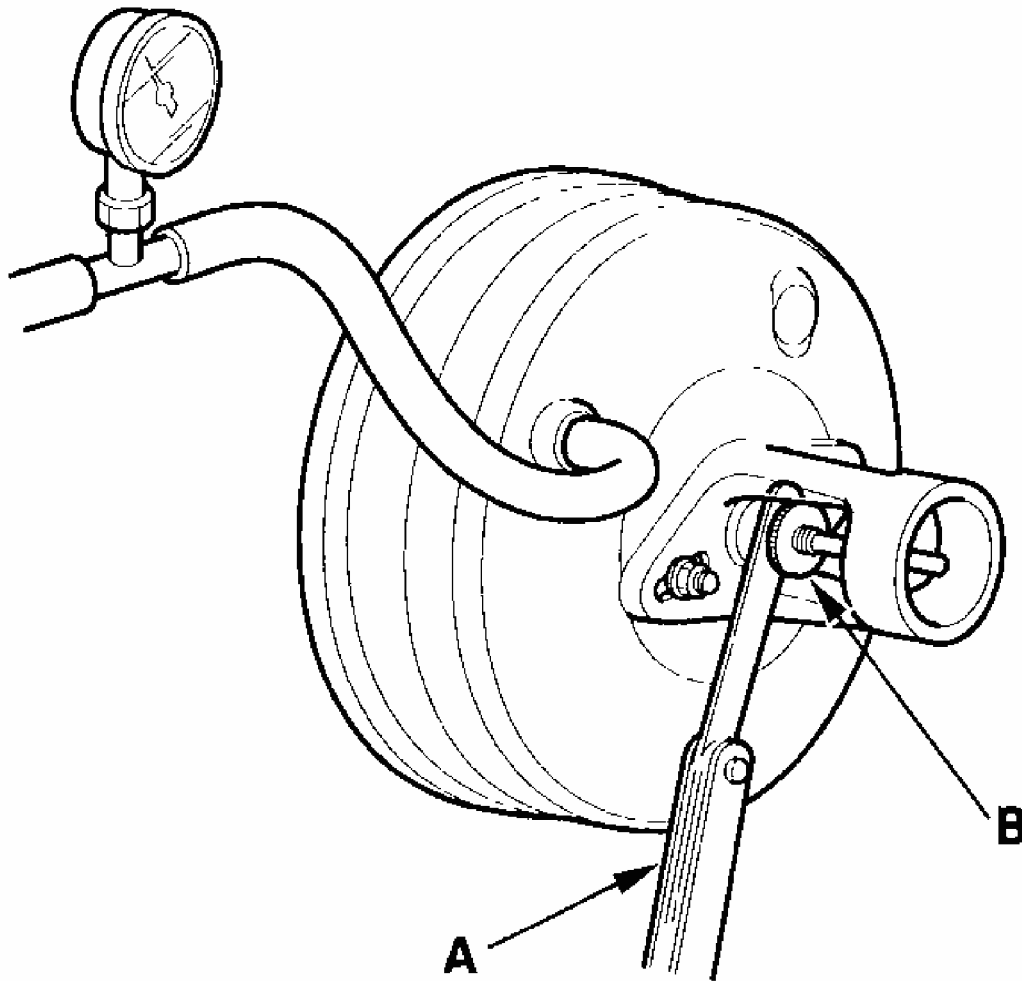

Fig. 36: Installing Special Tool Backwards On Booster And Torque Specifications
Courtesy of AMERICAN HONDA MOTOR CO., INC.

3. Install the master cylinder nuts (B), and tighten them to the specified torque.
4. Connect the booster in-line with a vacuum gauge (C) 0-101 kPa (0-760 mmHg, 0-30 in.Hg) to the booster's engine vacuum supply, and maintain an engine speed that will deliver 66 kPa (500 mmHg, 20 in.Hg) vacuum.
5. With a feeler gauge (A), measure the clearance between the gauge body and the adjusting nut (B) as shown.

If the clearance between the gauge body and the adjusting nut is 0.4 mm (0.02 in.), the pushrod-to-piston clearance is 0 mm. However, if the clearance between the gauge body and the adjusting nut is 0 mm, the pushrod-to-piston clearance is 0.4 mm (0.02 in.) or more. Therefore it must be adjusted and rechecked.

Clearance: 0-0.4 mm (0-0.02 in.)



G03679183

Fig. 37: Measuring Clearance Between Gauge Body
Courtesy of AMERICAN HONDA MOTOR CO., INC.

6. If the clearance is incorrect, loosen the star locknut (A), and turn the adjuster (B) in or out to adjust.
 - Adjust the clearance while the specified vacuum is applied to the booster.
 - Hold the yoke (C) while adjusting.

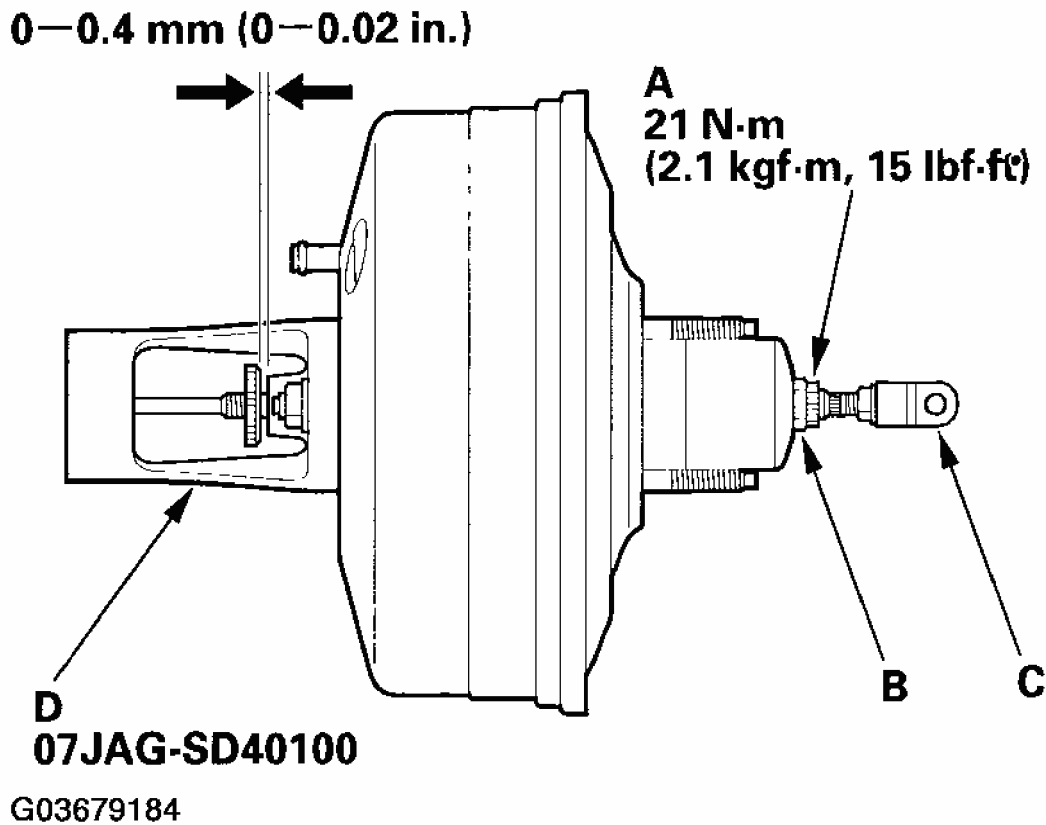
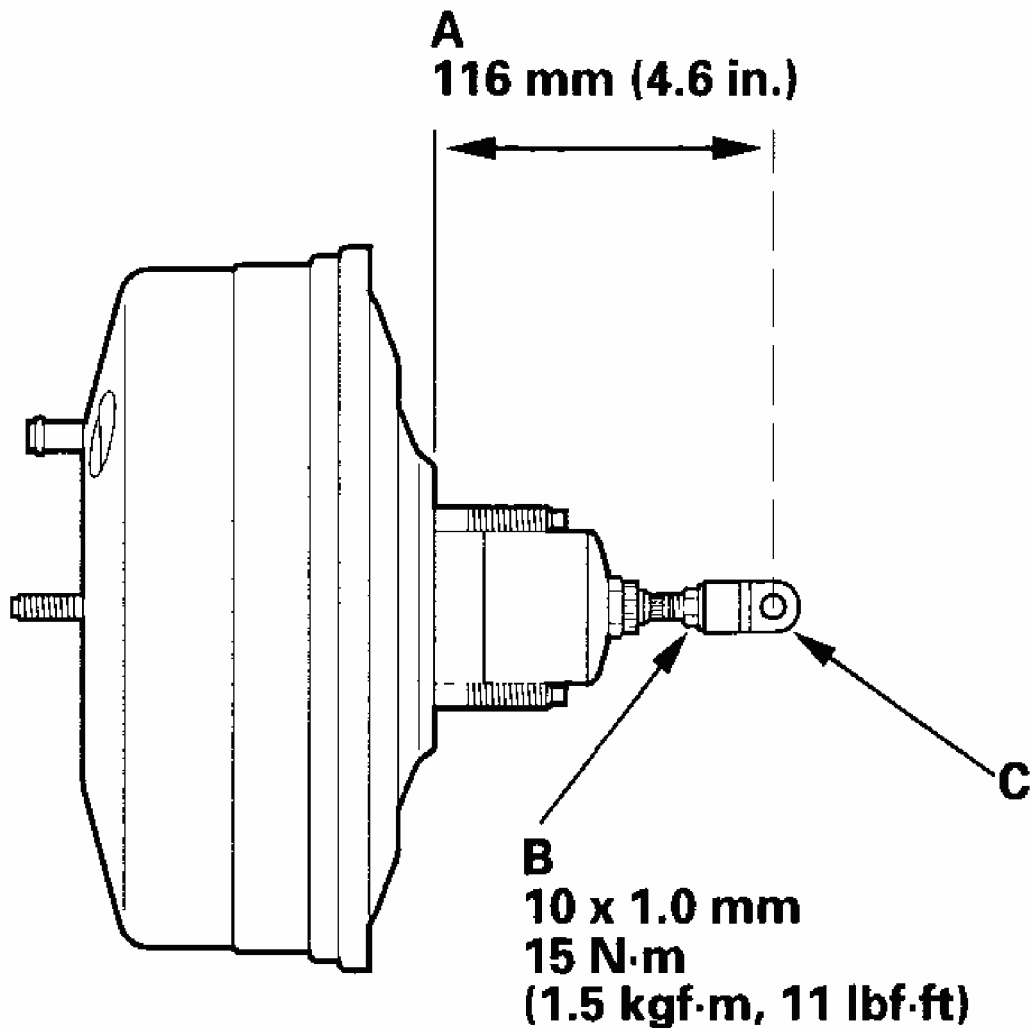

Fig. 38: Adjusting Clearance While Specified Vacuum Is Applied To Booster And Torque Specifications

Courtesy of AMERICAN HONDA MOTOR CO., INC.

7. Tighten the star locknut securely.
8. Remove the special tool (D).
9. Check the pushrod length (A) as shown if the booster is removed. If the length is incorrect, loosen the pushrod locknut (B), and turn the yoke (C) in or out to adjust.



G03679185

Fig. 39: Checking The Pushrod Length With Torque Specifications
Courtesy of AMERICAN HONDA MOTOR CO., INC.

10. Install the master cylinder (see)**MASTER CYLINDER REPLACEMENT** .

BRAKE BOOSTER TEST

FUNCTIONAL TEST

1. With the engine stopped, press the brake pedal several times to deplete the vacuum reservoir, then press the pedal hard, and hold it for 15 seconds. If the pedal sinks, either the master cylinder is bypassing internally, or the brake system (master cylinder, lines, modulator, or caliper) is leaking.

2004 Honda Element DX

2003-06 BRAKES Conventional Brake Components - Element

2. Start the engine with the brake pedal pressed. If the pedal sinks slightly, the vacuum booster is operating normally. If the pedal height does not vary, the booster or check valve is faulty.
3. With the engine running, press the brake pedal lightly and shift the transmission to the D position. Apply just enough pressure to hold back automatic transmission creep. If the brake pedal sinks more than 10 mm (3/8 in.) in 3 minutes, the master cylinder is faulty. A slight change in pedal height when the A/C compressor cycles on and off is normal. (The A/C compressor load changes the vacuum available to the booster.)

LEAK TEST

1. Press the brake pedal with the engine running, then stop the engine. If the pedal height does not vary while pressed for 30 seconds, the vacuum booster is OK. If the pedal height rises go to step 6 . If it does not rise go to 2 .
2. Start the engine and let it idle for 30 seconds. Press the brake pedal several times using normal pressure. When the pedal is first pressed, it should be low. On consecutive applications, the pedal height should gradually rise. Does the pedal rise on each consecutive application? If it rises the booster is OK. If it does not, go to step 3 .
3. Disconnect the brake booster vacuum hose (A) at the booster. Then check valve (B) is built into the hose.

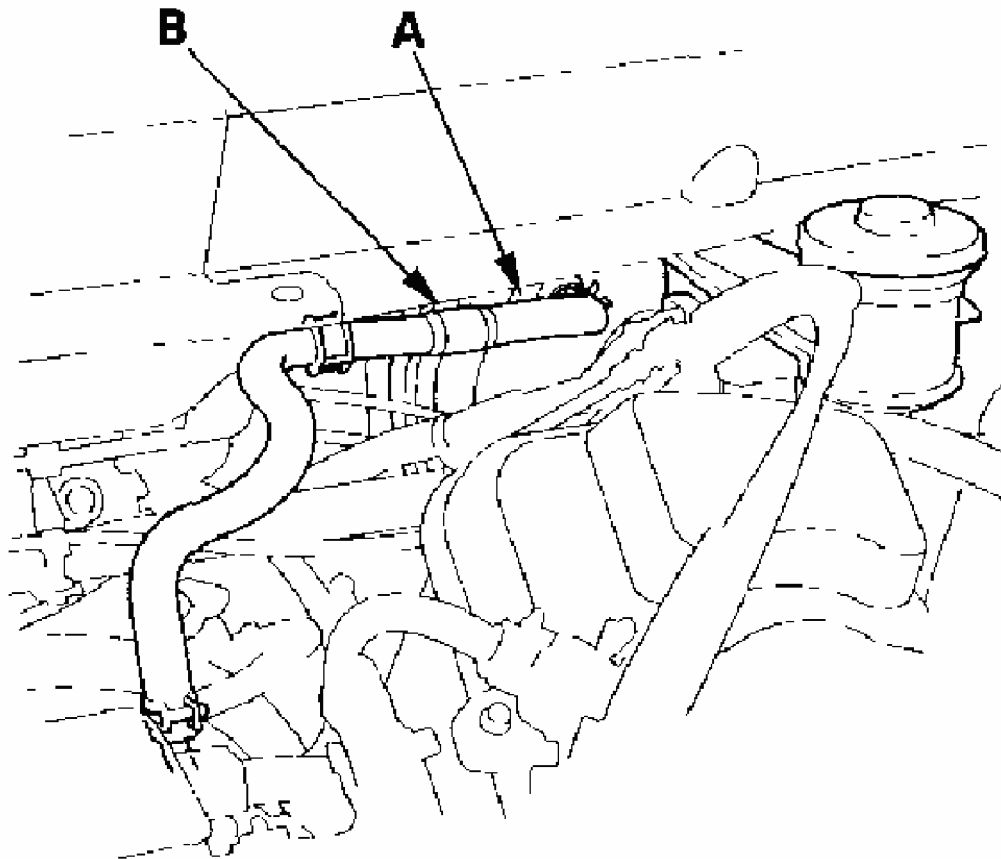

G03679186

Fig. 40: Disconnecting Brake Booster Vacuum Hose At Booster
Courtesy of AMERICAN HONDA MOTOR CO., INC.

4. Start the engine, and let it idle. There should be vacuum available. If no vacuum is available, the check valve is not working properly. Replace the brake booster vacuum hose and check valve, and retest. If vacuum is found, go to step 5 .
5. Reconnect the brake booster vacuum hose.
6. Start the engine, and then pinch the brake booster vacuum hose between the check valve and the booster.
7. Turn the engine off, and wait 30 seconds. Press the brake pedal several times using normal pressure. When the pedal is first pressed, it should be low. On consecutive applications, the pedal height should gradually rise.
 - If the pedal position does not vary, replace the seal between the master cylinder and the booster. If OK replace the brake booster.

- If the pedal position varies, replace the brake booster vacuum hose/check valve assembly.

BRAKE BOOSTER REPLACEMENT

1. Remove the master cylinder (see)**MASTER CYLINDER REPLACEMENT** .
2. Remove the air cleaner assembly (A).

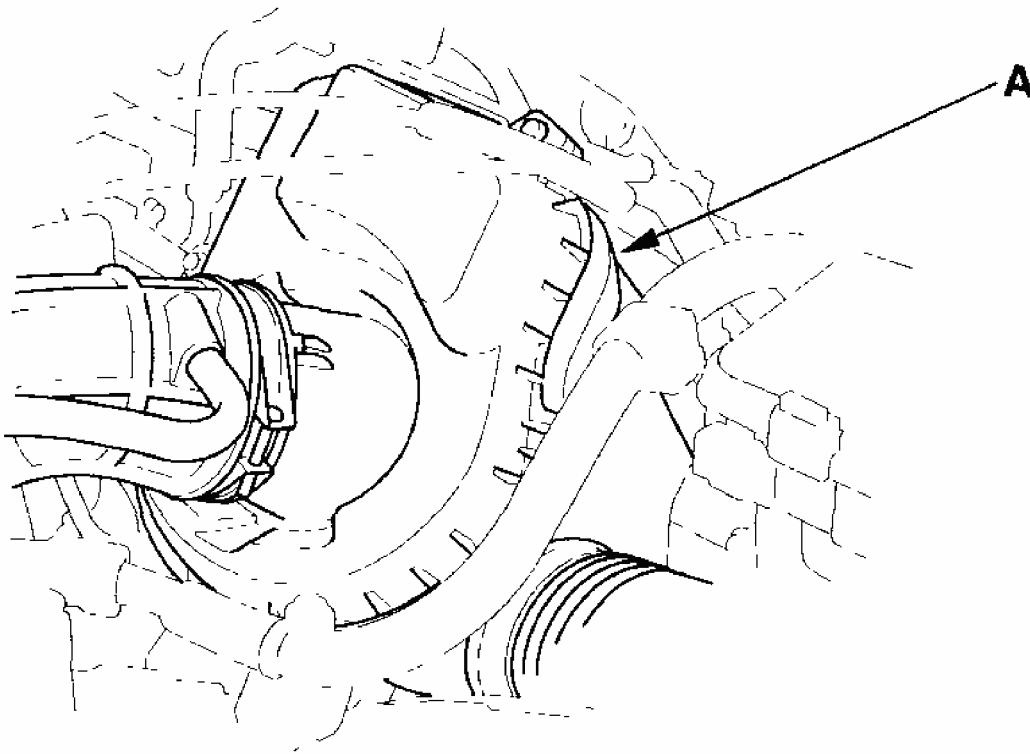

G03679187

Fig. 41: Removing Air Cleaner Assembly
Courtesy of AMERICAN HONDA MOTOR CO., INC.

3. Disconnect the vacuum hose (A) from the brake booster.

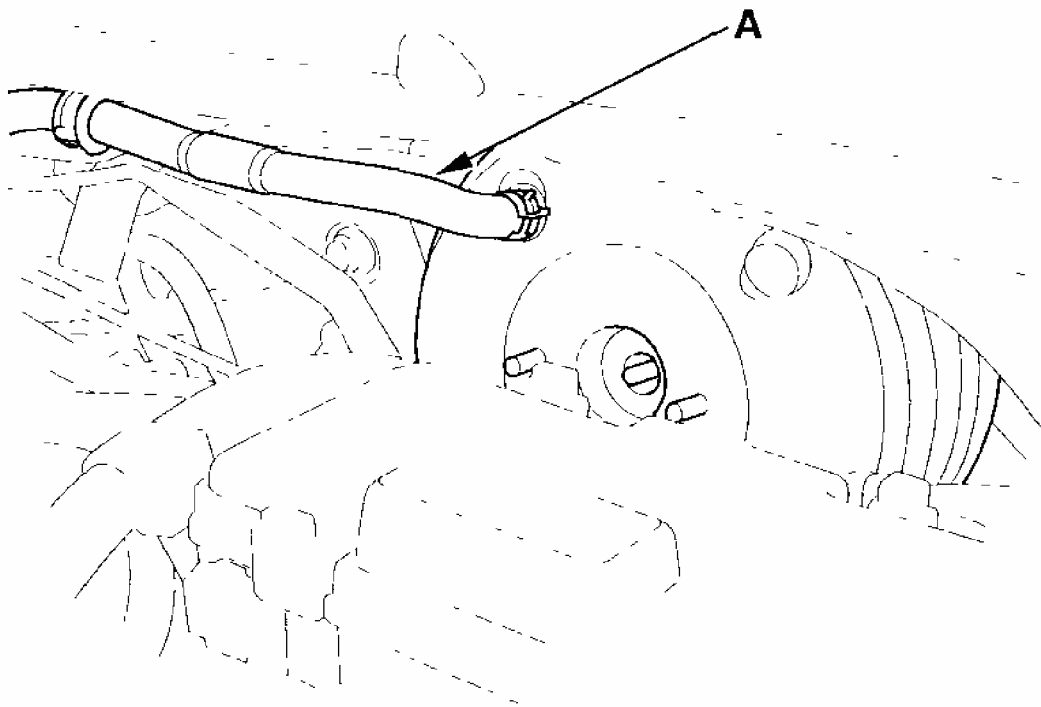

G03679188

Fig. 42: Disconnecting Vacuum Hose From Brake Booster
Courtesy of AMERICAN HONDA MOTOR CO., INC.

4. Remove the clip (A) and the joint pin (B), and disconnect the yoke from the brake pedal.

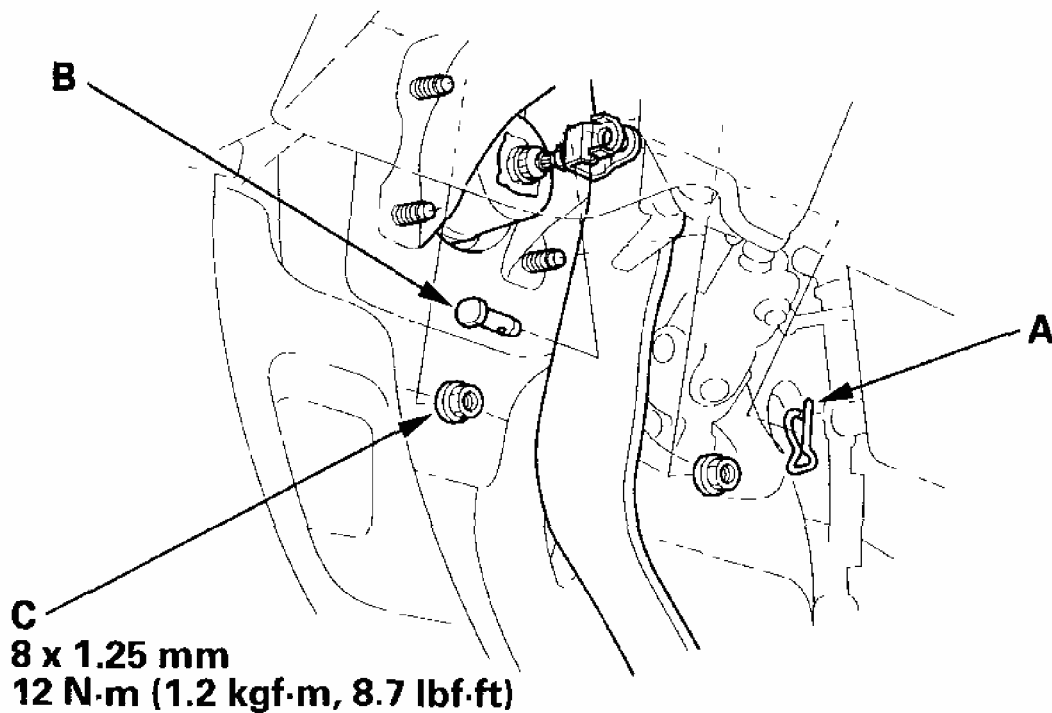

G03679189

Fig. 43: Removing Clip And Joint Pin And Disconnecting Yoke From Brake Pedal With Torque Specifications

Courtesy of AMERICAN HONDA MOTOR CO., INC.

5. Remove the brake booster mounting nuts (C).
6. Remove the brake booster (A) from the engine compartment.

NOTE:

- Be careful not to damage the booster surfaces and threads of the booster stud bolts.
- Be careful not to bend or damage the brake lines.

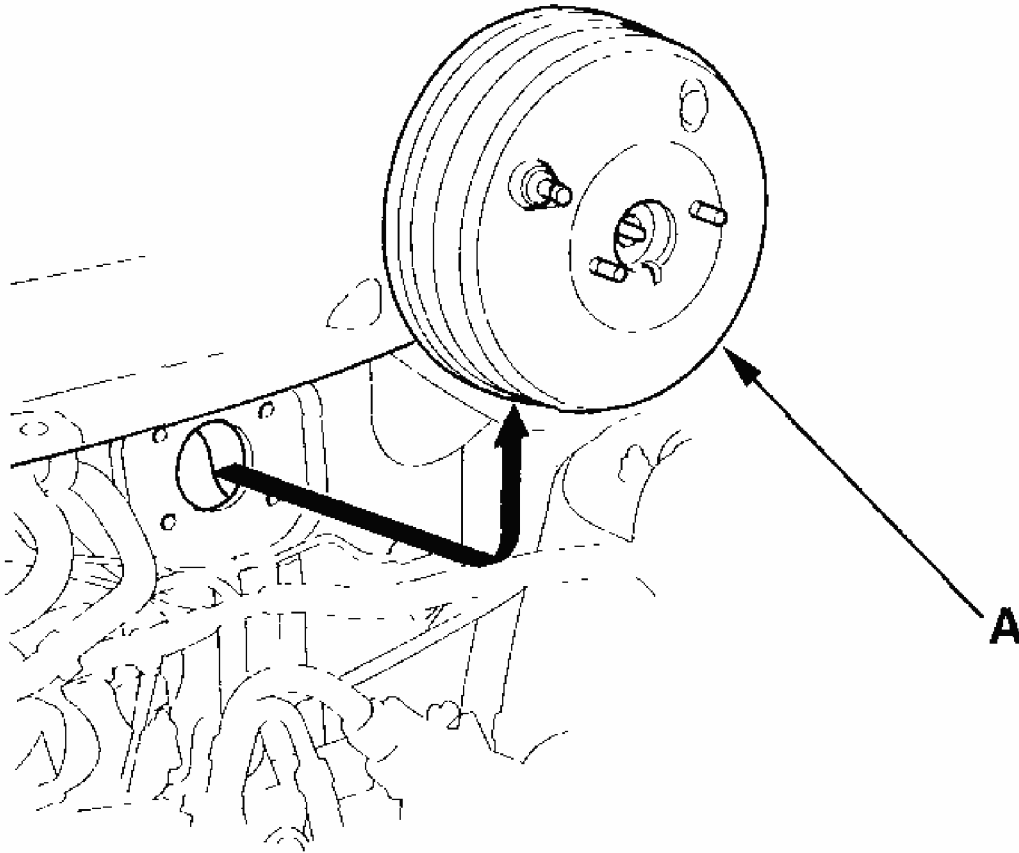

G03679190

Fig. 44: Removing Brake Booster From Engine Compartment
Courtesy of AMERICAN HONDA MOTOR CO., INC.

7. Install the brake booster in the reverse order of removal, and note these items:
 - Adjust the pushrod clearance before installing the brake booster (see)**MASTER CYLINDER INSPECTION** .
 - Use a new clip whenever installing.
 - Replace master cylinder pushrod seal.
 - After installing the brake booster and master cylinder, fill the reservoir with new brake fluid, bleed the brake system (see)**BRAKE SYSTEM BLEEDING** , and adjust the brake pedal height and free play (see)**BRAKE PEDAL AND BRAKE PEDAL POSITION SWITCH ADJUSTMENT** .

REAR BRAKE PAD INSPECTION AND REPLACEMENT

CAUTION: Frequent inhalation of brake pad dust, regardless of material composition, could be hazardous to your health.

- **Avoid breathing dust particles.**
- **Never use an air hose or brush to clean brake assemblies. Use an OSHA-approved vacuum cleaner.**

INSPECTION

1. Raise the rear of the vehicle, and support it with safety stands in the proper locations (see **SAFETY STANDS**).
2. Remove the rear wheels.
3. Check the thickness of the inner pad (A) and outer pad (B). Do not include the thickness of the brake pad backing plate.

Brake pad thickness:

Standard: 8.6-9.7 mm (0.34-0.38 in.)

Service limit: 1.6 mm (0.06 in.)

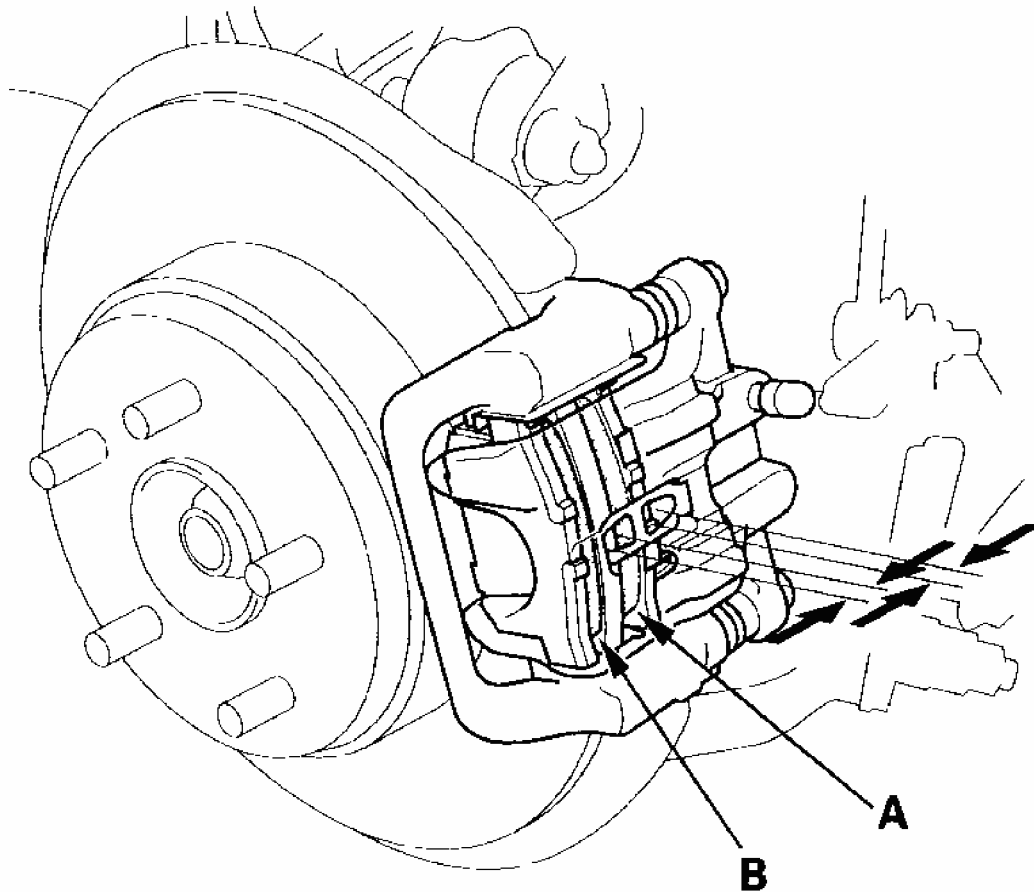

G03679191

Fig. 45: Checking Thickness Of The Inner Pad (A) And Outer Pad (B)
Courtesy of AMERICAN HONDA MOTOR CO., INC.

4. If the brake pad thickness is less than the service limit, replace all the brake pads as a set.

REPLACEMENT

1. Hold the pins (A) with a wrench, being careful not to damage the pin boots. Remove the caliper bolts (B), and remove the caliper (C) with inner pad from the caliper bracket.

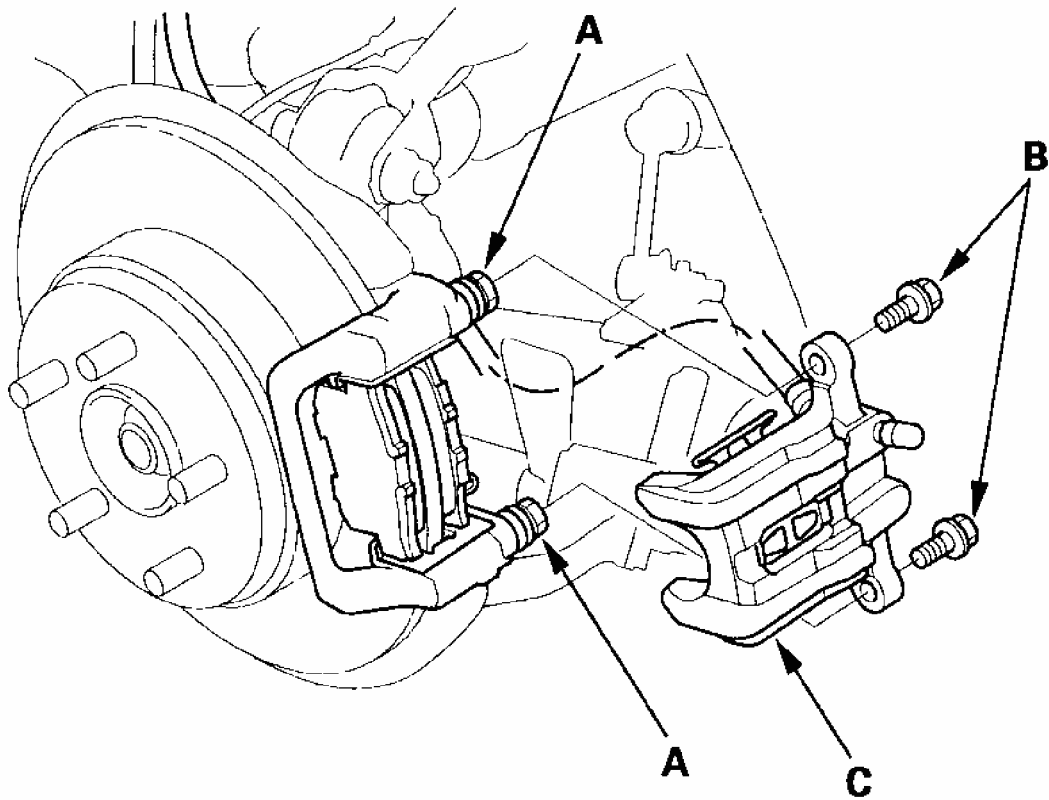

G03679192

Fig. 46: Removing Caliper With Inner Pad From Caliper Bracket
Courtesy of AMERICAN HONDA MOTOR CO., INC.

2. Remove the pad shim (A) and inner pad (B), and outer pad (C).

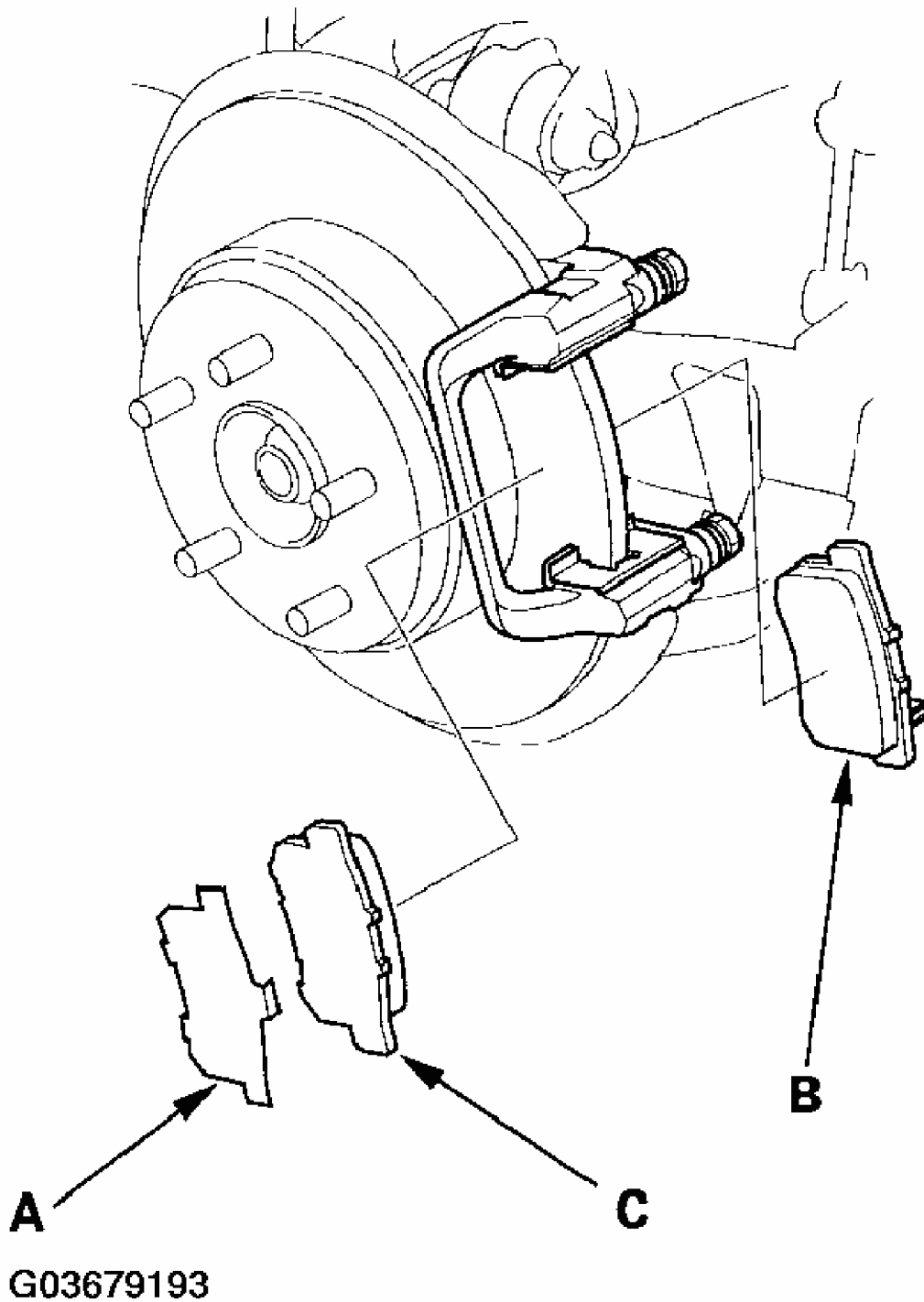
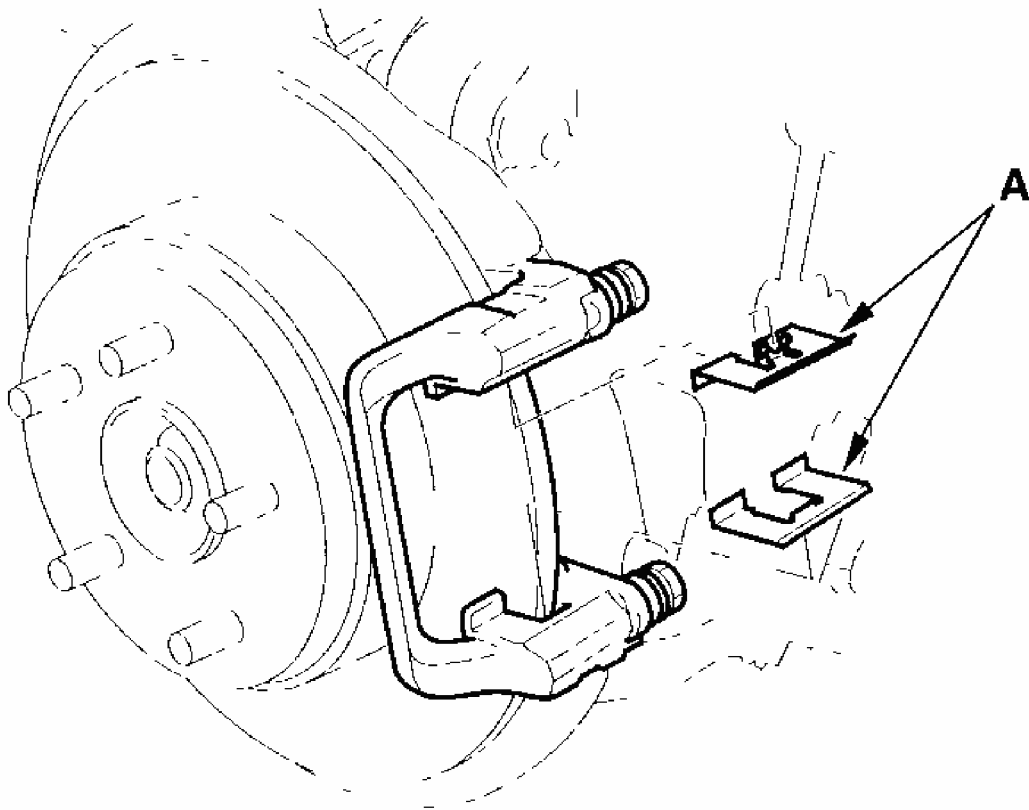

Fig. 47: Removing Pad Shim And Inner Pad And Outer Pad
Courtesy of AMERICAN HONDA MOTOR CO., INC.

3. Remove the pad retainers (A). Clean the upper and lower pad retainers; remove any

corrosion.



G03679194

Fig. 48: Removing Pad Retainers

Courtesy of AMERICAN HONDA MOTOR CO., INC.

4. Clean the caliper thoroughly; remove any rust, and check for grooves and cracks.
5. Check the brake disc for damage and cracks.
6. Install the pad retainers.
7. Apply a thin coat of M-77 assembly paste (P/N 08798-9010) to both sides of the pad shim (A), the back of the inner pad (B) and outer pad (C), and the other areas indicated by the arrows. Wipe excess assembly paste off the shim. Contaminated brake discs and brake pads reduce stopping ability. Keep assembly paste off the brake discs and brake pad material.

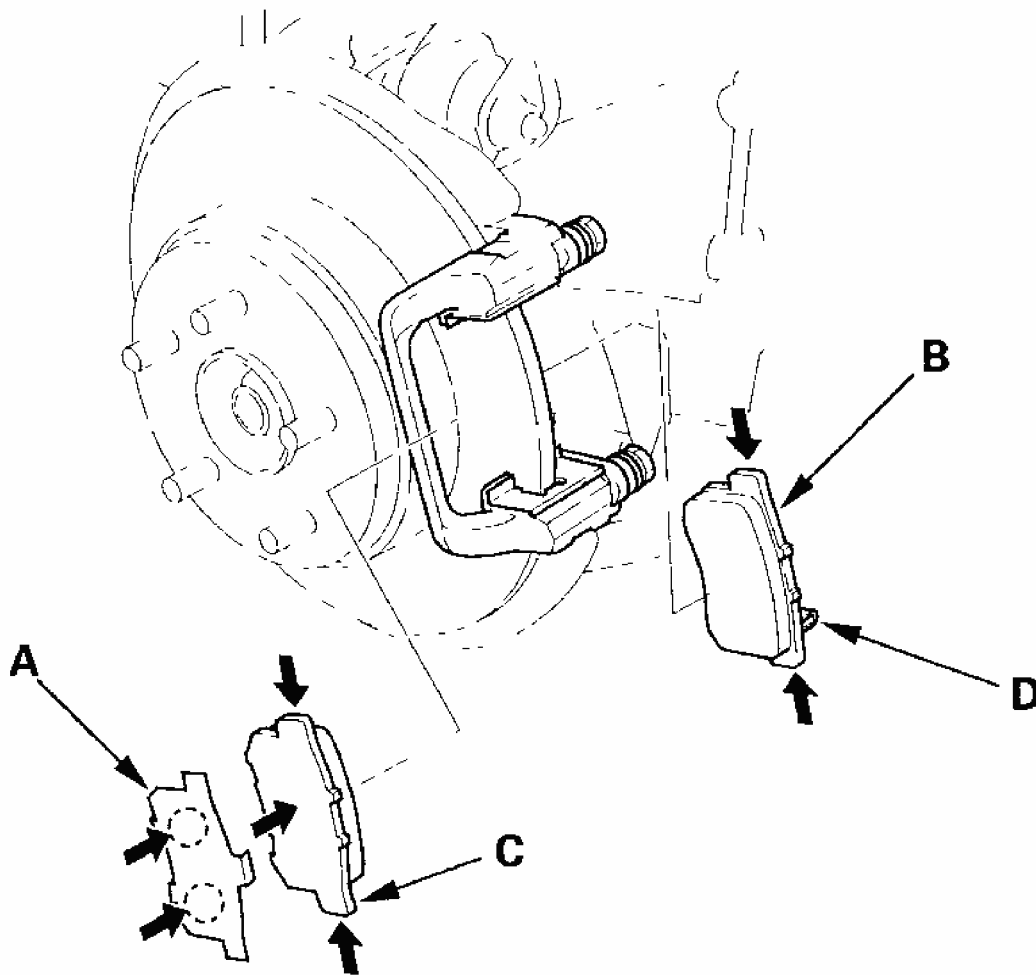

G03679195

Fig. 49: Applying Thin Coat Of M-77 Assembly Paste
 Courtesy of AMERICAN HONDA MOTOR CO., INC.

8. Install the brake pads and pad shims correctly. Install the brake pads with the wear indicator (D) on the bottom inside.

If you are reusing the brake pads, always reinstall the brake pads in their original positions to prevent a momentary loss of braking efficiency.

9. Push in the piston (A) so that the caliper will fit over the brake pads. Check the brake fluid level. The brake fluid may overflow if the reservoir is too full. Make sure that the piston boot is in position to prevent damaging it when installing the caliper.

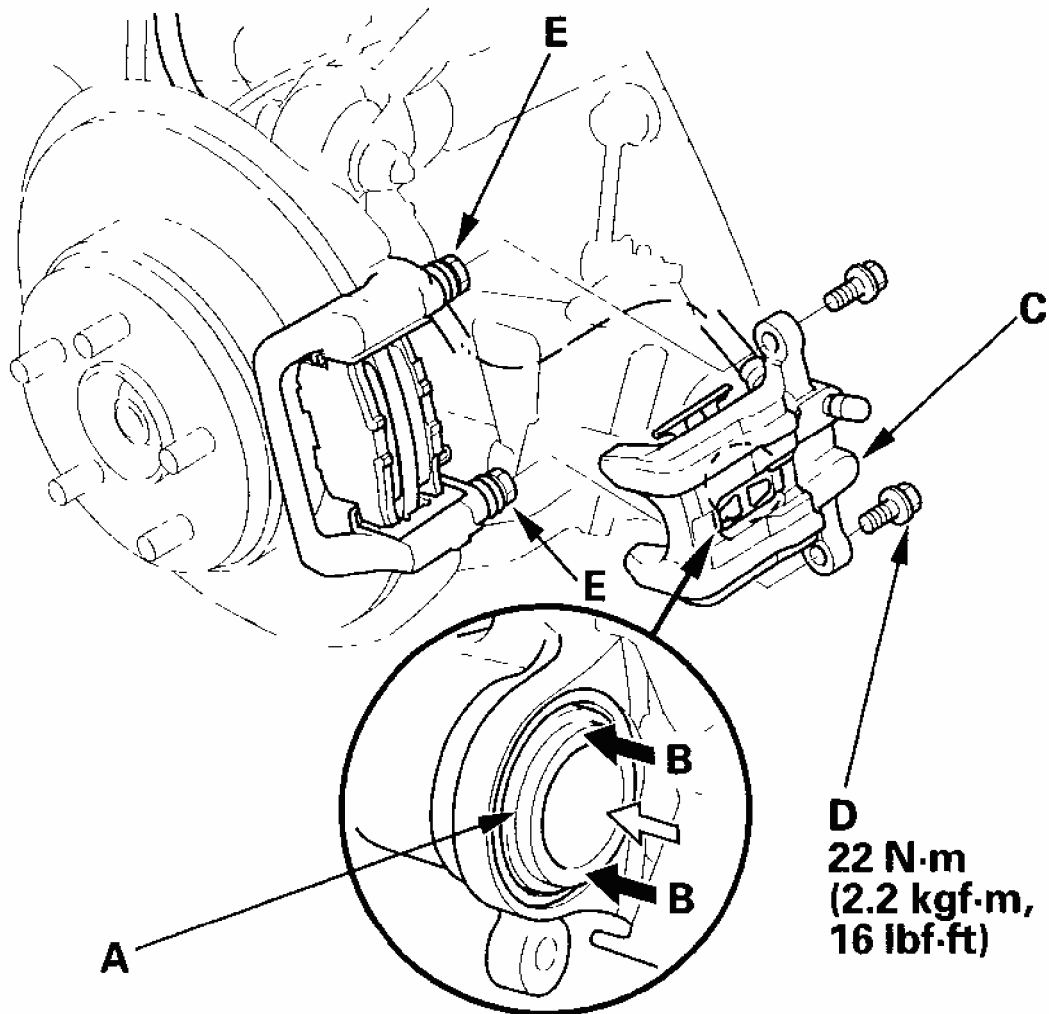

G03679196

Fig. 50: Pushing Piston For Caliper To Fit Over Brake Pads And Torque Specifications

Courtesy of AMERICAN HONDA MOTOR CO., INC.

10. Apply a thin coat of M-77 assembly paste (P/N 08798-9010) to the piston edges (B) on their mating surfaces against the inner pad.
11. Install the brake caliper (C) and caliper bolts (D), and torque them to the specified torque while holding the pin (E). Be careful not to damage the pin boots.
12. Press the brake pedal several times to seat the pads/pistons and restore brake pedal height.
13. After installation, check for leaks at hose and line joints or connections, and retighten if necessary.
14. Install the front wheels, and test-drive the vehicle.

REAR BRAKE DISC INSPECTION

RUNOUT

1. Raise the rear of the vehicle, and support it with safety stands in the proper locations (see **SAFETY STANDS**).
2. Remove the rear wheels.
3. Remove the brake pads (see)**REAR BRAKE PAD INSPECTION AND REPLACEMENT** .
4. Inspect the brake disc surface for damage and cracks. Clean the disc thoroughly and remove all rust.
5. Install suitable flat washers (A) and wheel nuts, and tighten the nuts to the specified torque value to hold the brake disc securely against the hub.

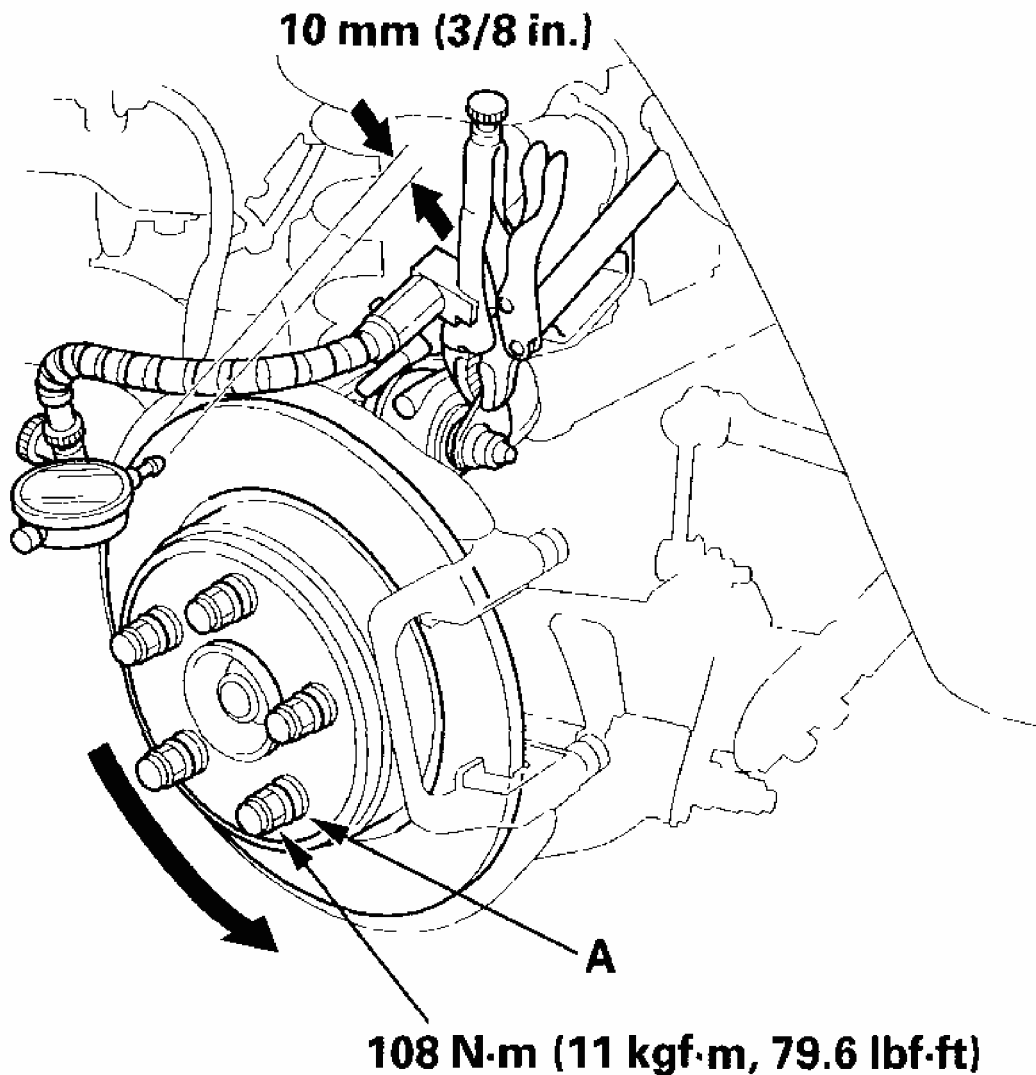

G03679197

Fig. 51: Installing Suitable Flat Washers And Wheel Nuts With Torque Specifications

Courtesy of AMERICAN HONDA MOTOR CO., INC.

6. Set up the dial gauge against the brake disc as shown, and measure the runout at 10 mm (3/8 in.) from the outer edge of the brake disc.

Brake disc runout:

Service limit: 0.10 mm (0.004 in.)

7. If the brake disc is beyond the service limit, refinish the disc.

Max. refinishing limit: 7.5 mm (0.30 in.)

NOTE:

- **If the brake disc is beyond the service limit for refinishing, replace it (see step 4 on KNUCKLE REPLACEMENT).**
- **A new brake disc should be refinished if its runout is greater than 0.10 mm (0.004 in.).**

THICKNESS AND PARALLELISM

1. Raise the rear of the vehicle, and support it with safety stands in the proper locations (see **SAFETY STANDS**).
2. Remove the rear wheels.
3. Remove the brake pads (see)**REAR BRAKE PAD INSPECTION AND REPLACEMENT** .
4. Using a micrometer, measure disc thickness at eight points, approximately 45ohm apart and 10 mm (3/8 in.) in from the outer edge of the disc.

Brake disc thickness:

Standard: 8.9-9.1 mm (0.350-0.358 in.)

Max. refinishing limit: 7.5 mm (0.30 in.)

Brake disc parallelism: 0.015 mm (0.0006 in.) max.

NOTE:

Parallelism is the maximum allowable difference between the thickness measurements.

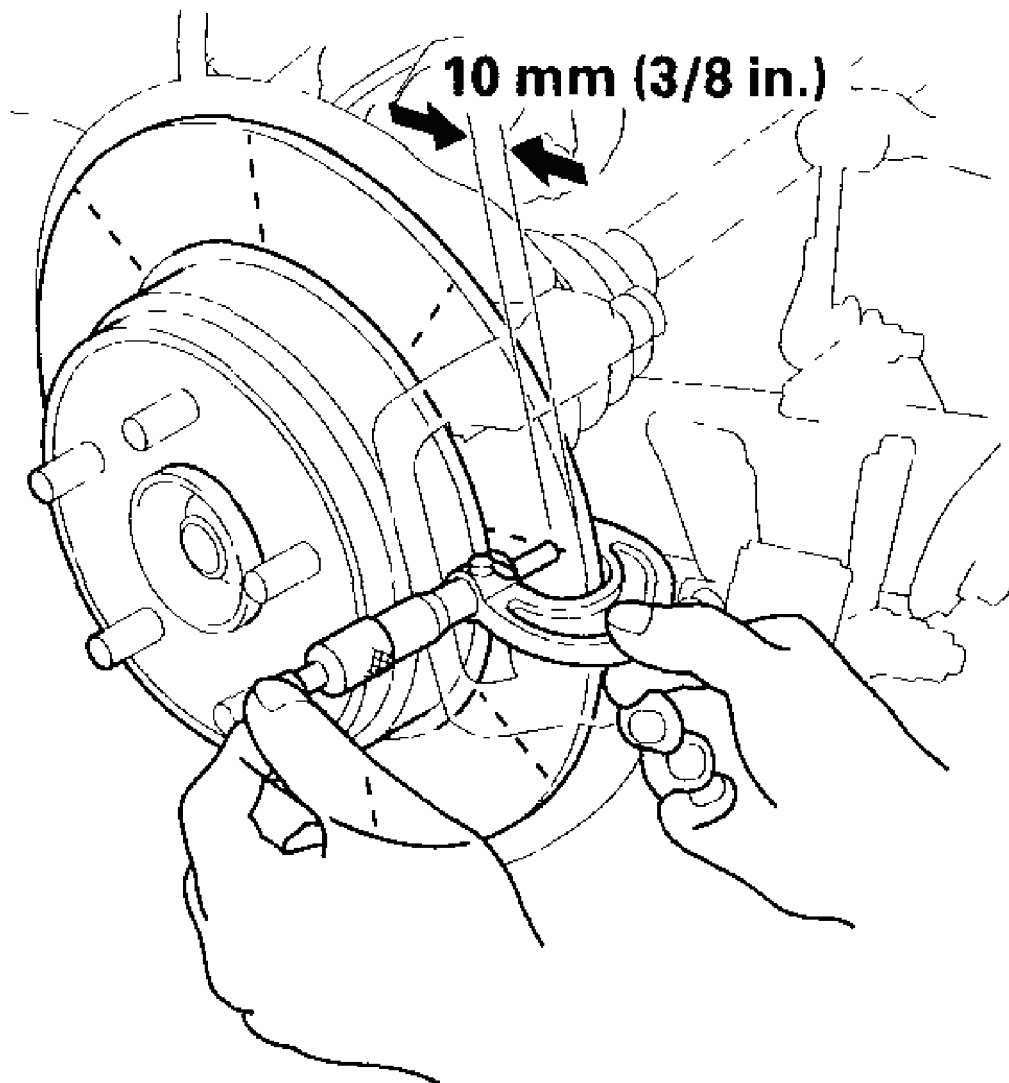

G03679198

Fig. 52: Measuring Disc Plate Thickness

Courtesy of AMERICAN HONDA MOTOR CO., INC.

5. If the smallest measurement is less than the maximum refinishing limit, replace the brake disc (see step 4 on **KNUCKLE REPLACEMENT**).
6. If the brake disc is beyond the service limit for parallelism, refinish the disc with an on-car brake lathe.

REAR BRAKE CALIPER OVERHAUL

CAUTION: Frequent inhalation of brake pad dust, regardless of material composition, could be hazardous to your health.

- **Avoid breathing dust particles.**
- **Never use an air hose or brush to clean brake assemblies. Use an OSHA-approved vacuum cleaner.**

Remove, disassemble, inspect, reassemble, and install the caliper, and note these items:

- Do not spill brake fluid on the vehicle; it may damage the paint; if brake fluid gets on the paint, wash it off immediately with water.
- To prevent dripping, cover disconnected hose joints with rags or shop towels.
- Clean all parts in brake fluid and air dry; blow out all passages with compressed air.
- Before reassembling, check that all parts are free of dirt and other foreign particles.
- Replace parts with new ones as specified in the illustration.
- Make sure no dirt or other foreign matter gets in the brake fluid.
- Make sure no grease or oil gets on the brake discs or pads.
- When reusing pads, always reinstall them in their original positions to prevent loss of braking efficiency.
- Do not reuse drained brake fluid.
- Always use Honda DOT 3 Brake Fluid from an unopened container. Using a non-Honda brake fluid can cause corrosion and shorten the life of the system.
- Do not mix different brands of brake fluid as they may not be compatible.
- Coat the piston, piston seal groove, and caliper bore with clean brake fluid.
- Replace all rubber parts with new ones.
- After installing the caliper, check the brake hose and line for leaks, interference, and twisting.

2004 Honda Element DX

2003-06 BRAKES Conventional Brake Components - Element

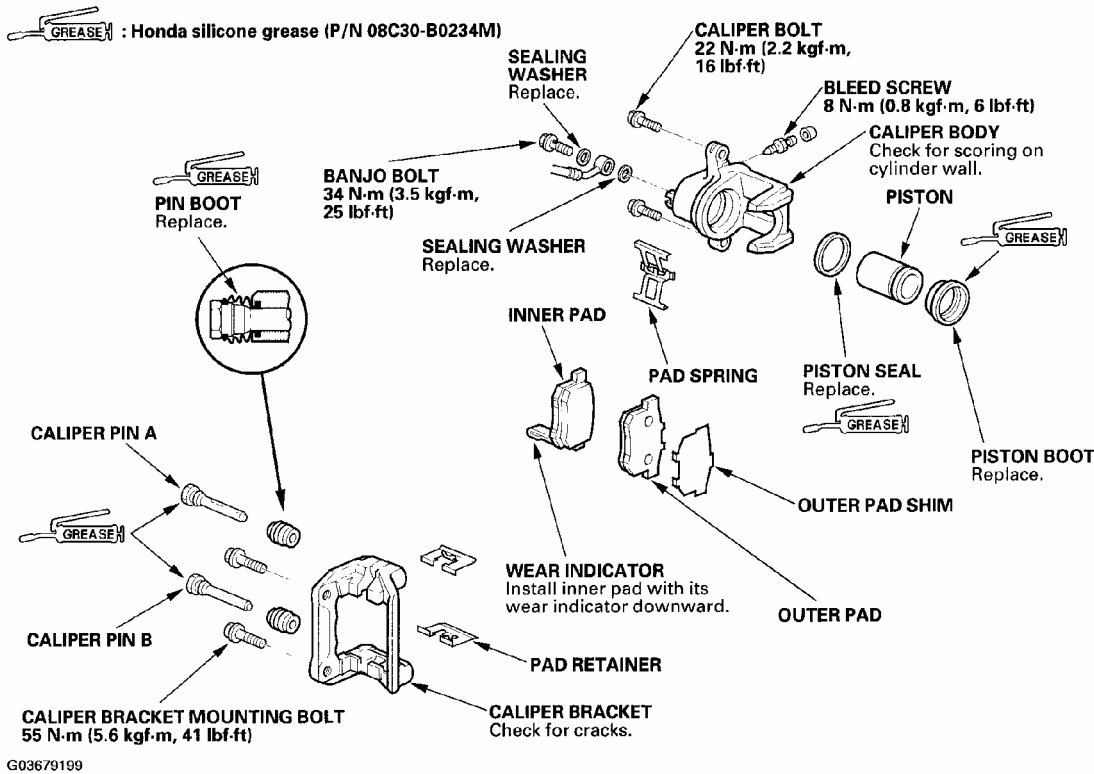

Fig. 53: Identifying Rear Brake Caliper
Courtesy of AMERICAN HONDA MOTOR CO., INC.

PARKING BRAKE INSPECTION

CAUTION: Frequent inhalation of brake pad dust, regardless of material composition, could be hazardous to your health.

- Avoid breathing dust particles.
- Never use an air hose or brush to clean brake assemblies. Use an OSHA-approved vacuum cleaner.

1. Raise the rear of the vehicle, and support it with safety stands in the proper locations (see **SAFETY STANDS**).
2. Remove the rear wheels.
3. Release the parking brake, and remove the rear brake caliper and disc/drum (see step 4 on **KNUCKLE REPLACEMENT**).

2004 Honda Element DX

2003-06 BRAKES Conventional Brake Components - Element

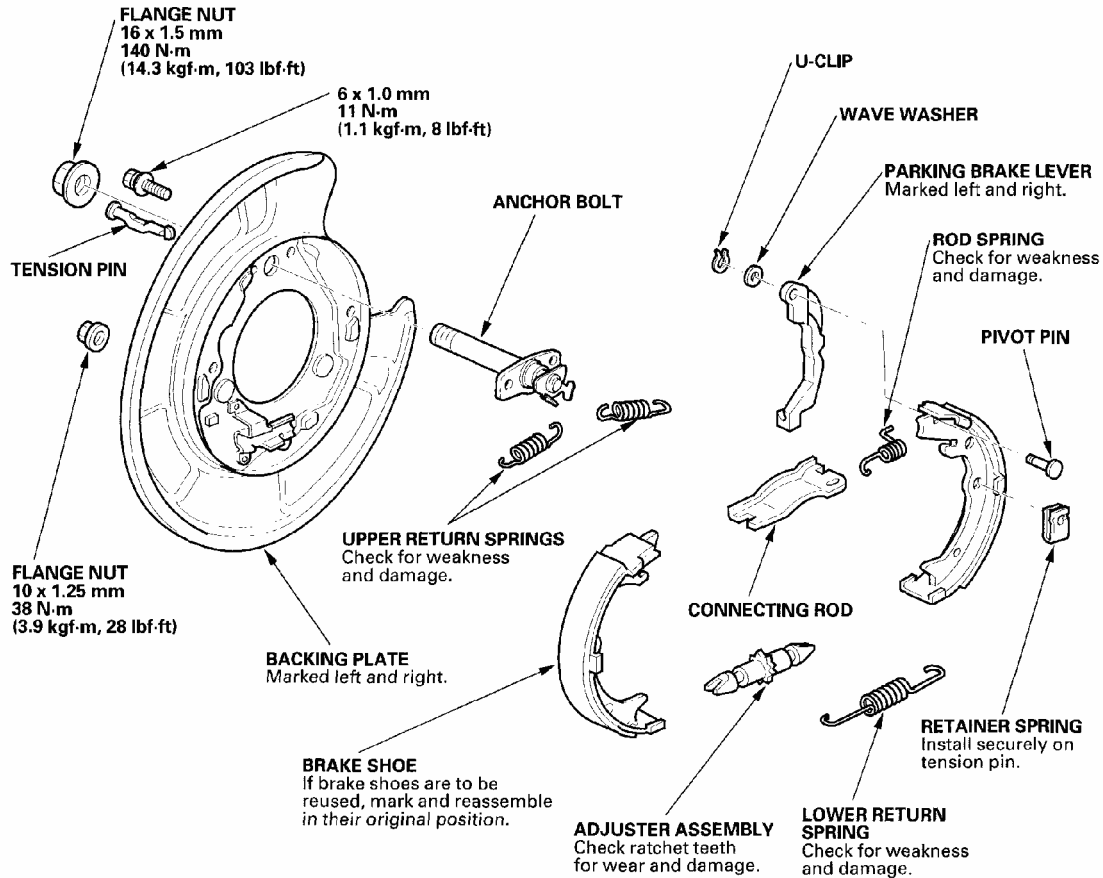

G03679200

Fig. 54: Releasing Parking Brake And Removing Rear Wheels With Torque Specifications
Courtesy of AMERICAN HONDA MOTOR CO., INC.

4. Check the parking brake linings (A) for cracking, glazing, wear, and contamination.

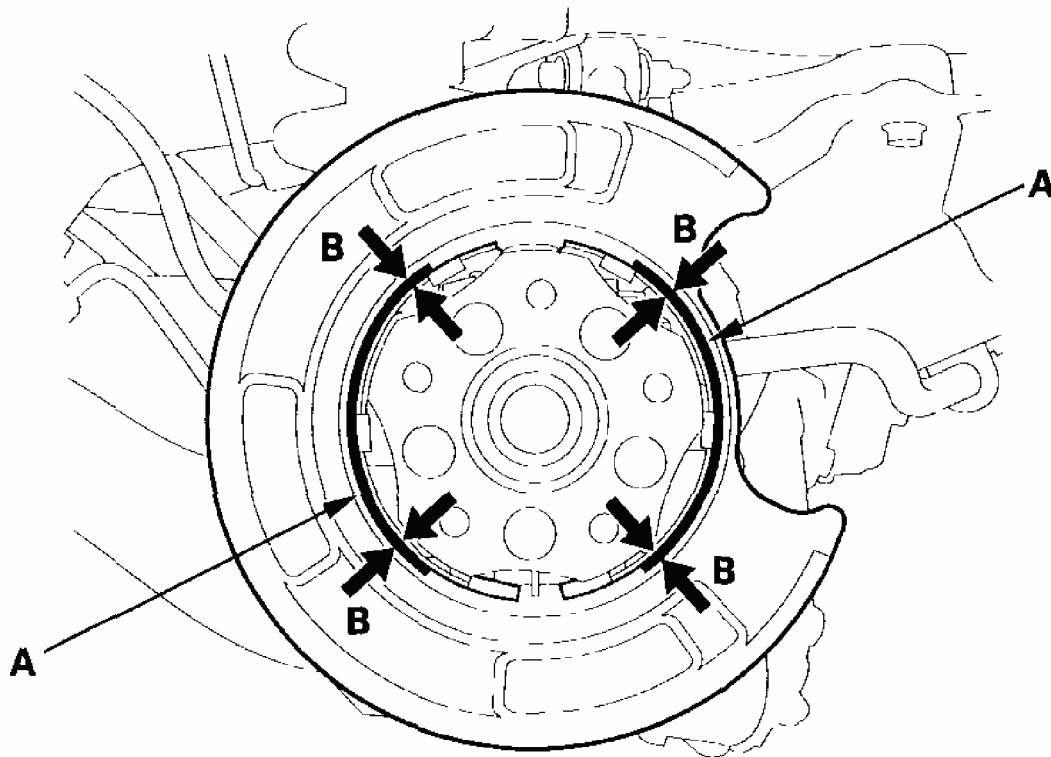

G03679201

Fig. 55: Checking Parking Brake Linings For Cracking
Courtesy of AMERICAN HONDA MOTOR CO., INC.

5. Measure the parking brake lining thickness (B). Measurement does not include brake shoe thickness.

Parking brake lining thickness:

Standard: 2.5 mm (0.098 in.)

Service limit: 1.0 mm (0.04 in.)

6. If the brake lining thickness is less than the service limit, replace all the parking brake shoes as a set.
7. Check the bearings in the hub unit for smooth operation.
8. Measure the inside diameter of the parking brake drum with inside vernier calipers.

Parking brake drum inside diameter:

Standard: 169.9-170.0 mm (6.689-6.693 in.)

Service limit: 171.0 mm (6.732 in.)

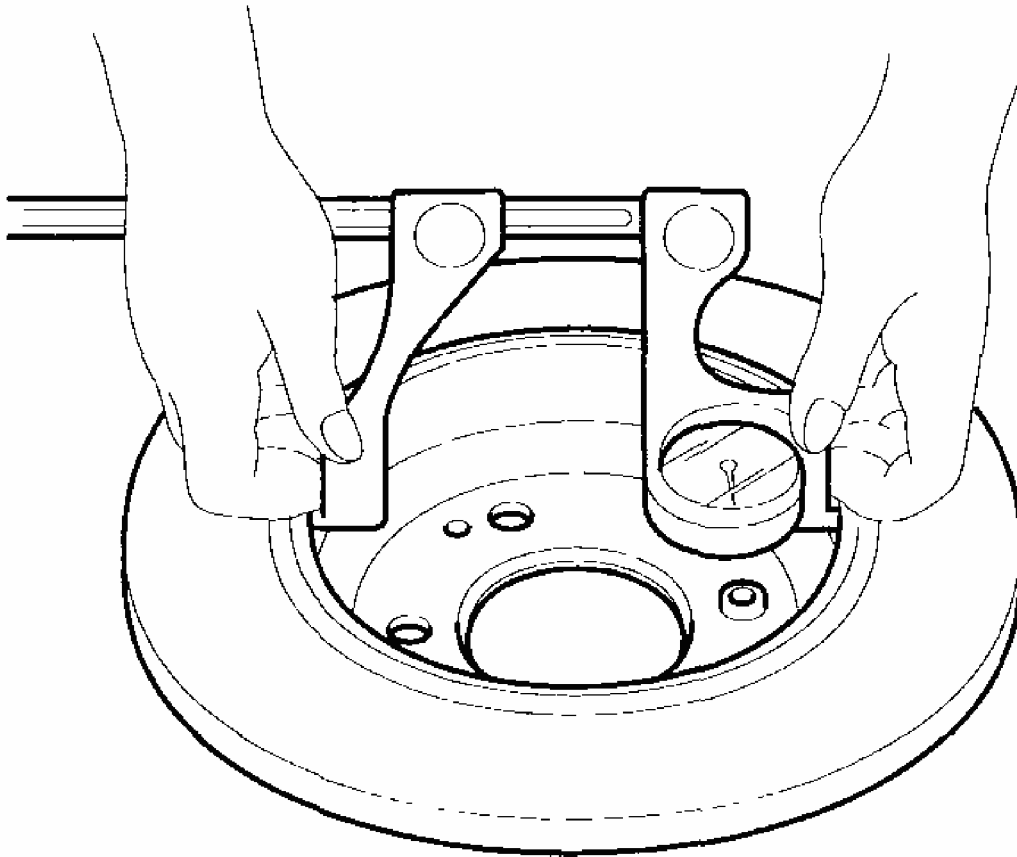

G03679202

Fig. 56: Measuring Inside Diameter Of Parking Brake Drum With Inside Vernier Calipers

Courtesy of AMERICAN HONDA MOTOR CO., INC.

9. If the inside diameter of the parking brake drum is more than the service limit, replace the rear brake disc/drum.
10. Check the parking brake drum for scoring, grooves, and cracks.

PARKING BRAKE SHOE REPLACEMENT

CAUTION: Frequent inhalation of brake pad dust, regardless of material composition, could be hazardous to your health.

- Avoid breathing dust particles.

- **Never use an air hose or brush to clean brake assemblies. Use an OSHA-approved vacuum cleaner.**

DISASSEMBLY

1. Raise the rear of the vehicle, and support it with safety stands in the proper locations (see **SAFETY STANDS**).
2. Remove the rear wheels.
3. Release the parking brake, and remove the rear brake caliper and brake disc/drum (see step 4 on **KNUCKLE REPLACEMENT**).
4. Disconnect and remove the upper return springs (A).

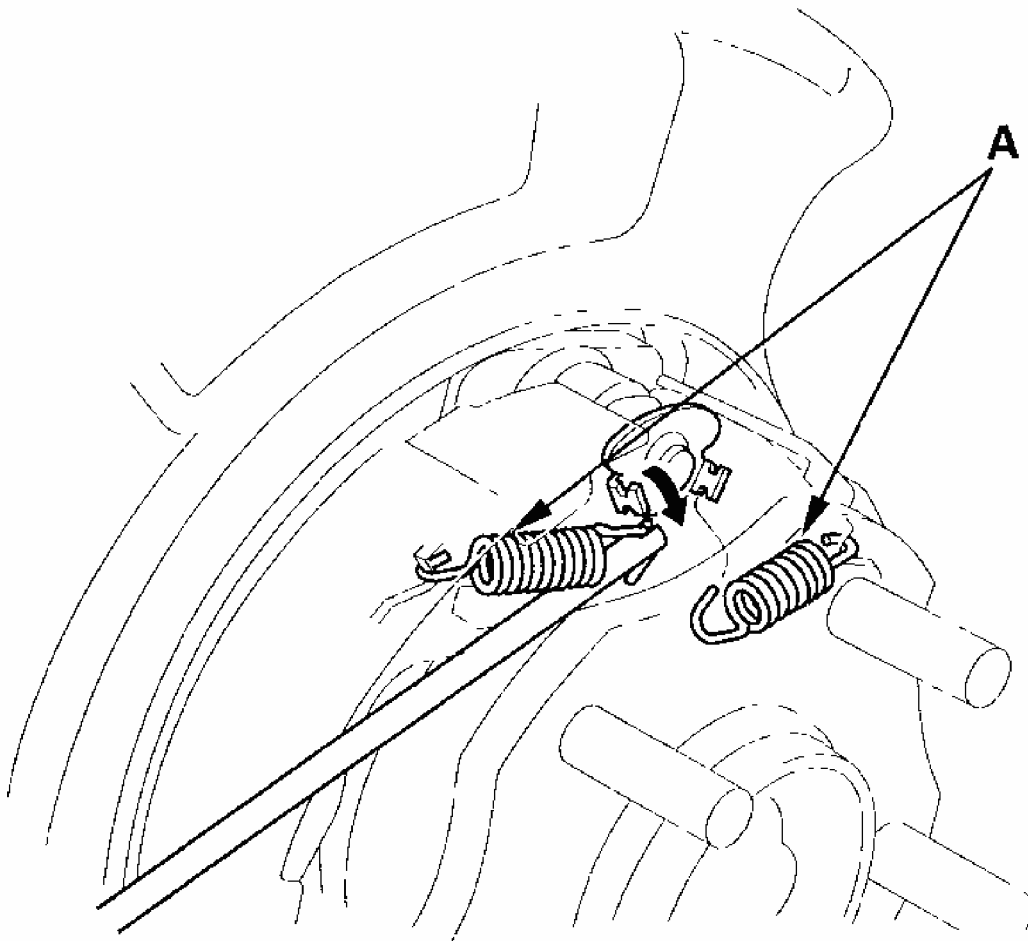

G03679203

Fig. 57: Disconnecting Upper Return Springs
Courtesy of AMERICAN HONDA MOTOR CO., INC.

5. Remove the tension pins (A) by pushing the retainer springs (B) and turning the pins.

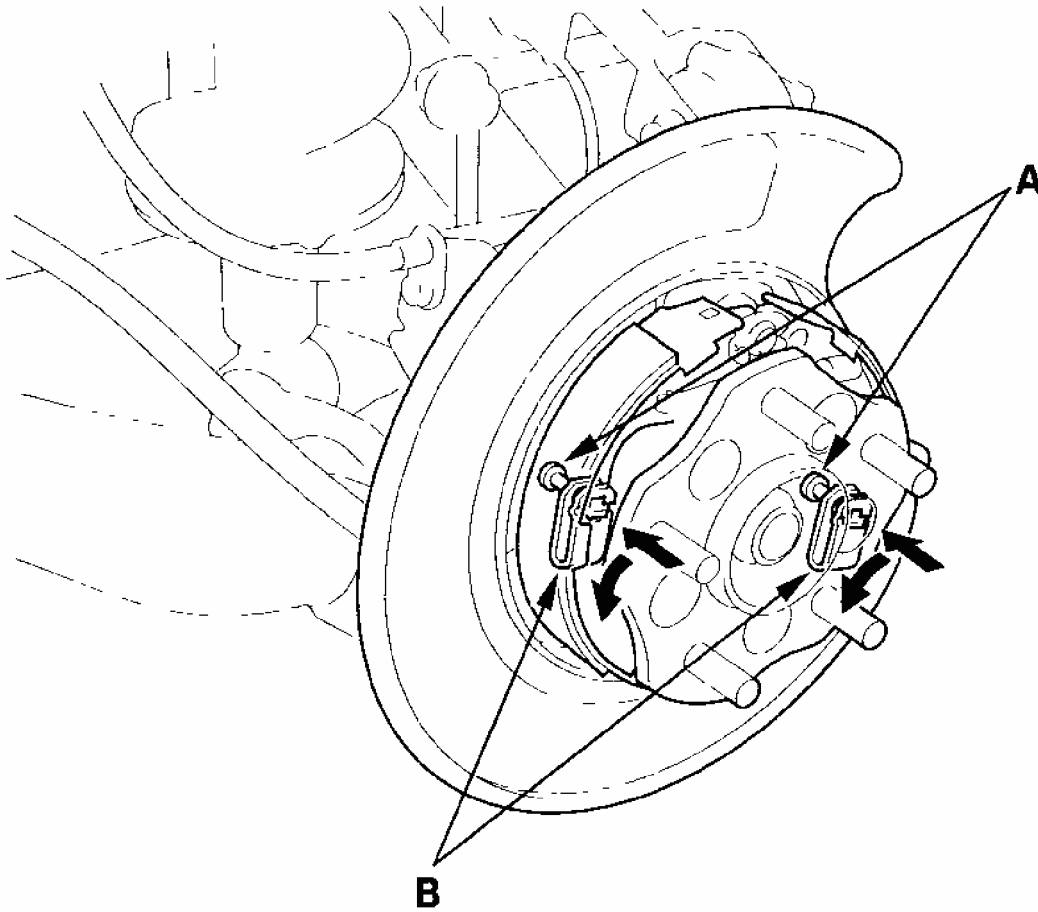

G03679204

Fig. 58: Removing Tension Pins

Courtesy of AMERICAN HONDA MOTOR CO., INC.

6. Disconnect the rod spring (A), and remove the connecting rod (B).

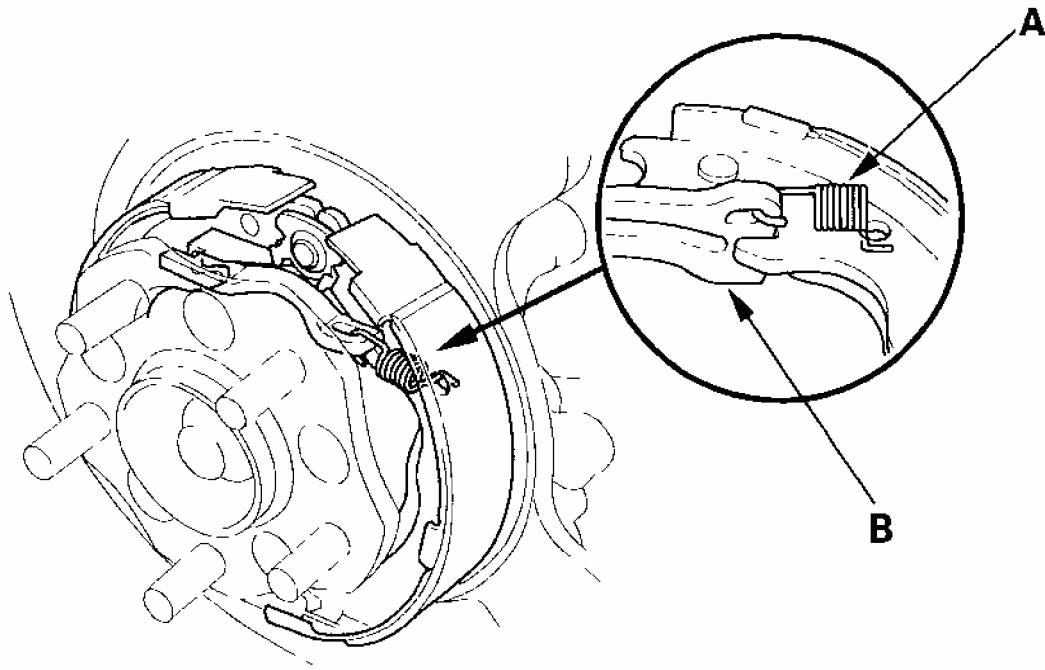

G03679205

Fig. 59: Disconnecting Rod Spring And Removing Connecting Rod
Courtesy of AMERICAN HONDA MOTOR CO., INC.

7. Lower the parking brake shoe assembly.
8. Remove the forward brake shoe by removing the lower return spring (A) and adjuster assembly (B).

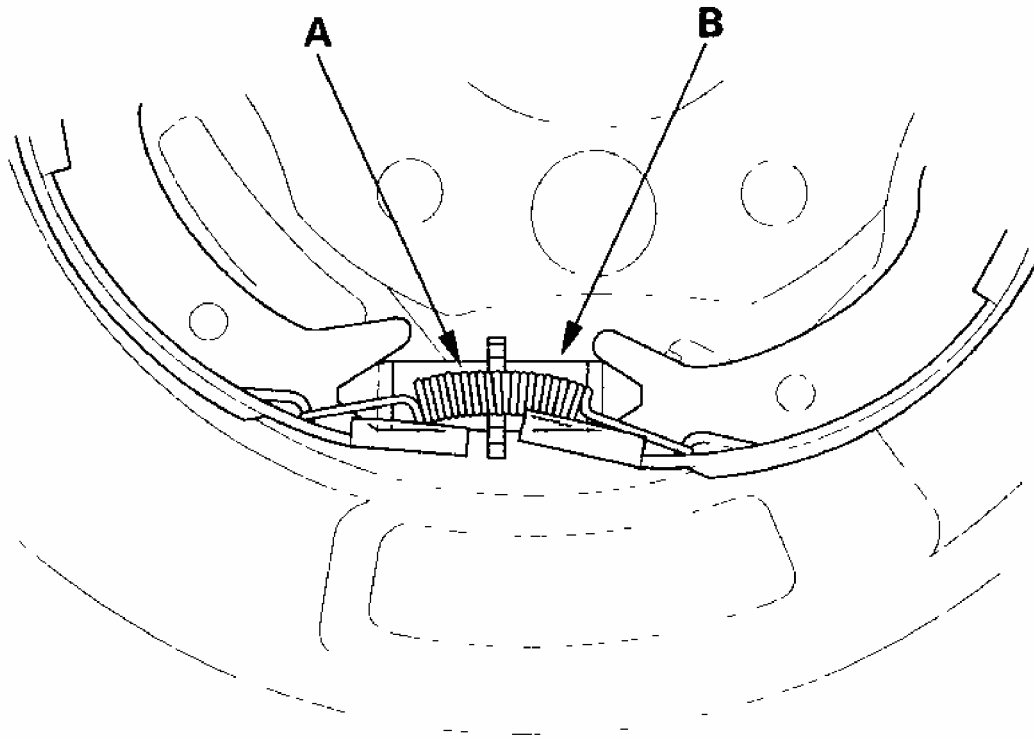

G03679206

Fig. 60: Removing Forward Brake Shoe
Courtesy of AMERICAN HONDA MOTOR CO., INC.

9. Remove the rearward brake shoe by disconnecting the parking brake cable (A) from the parking brake lever (B).

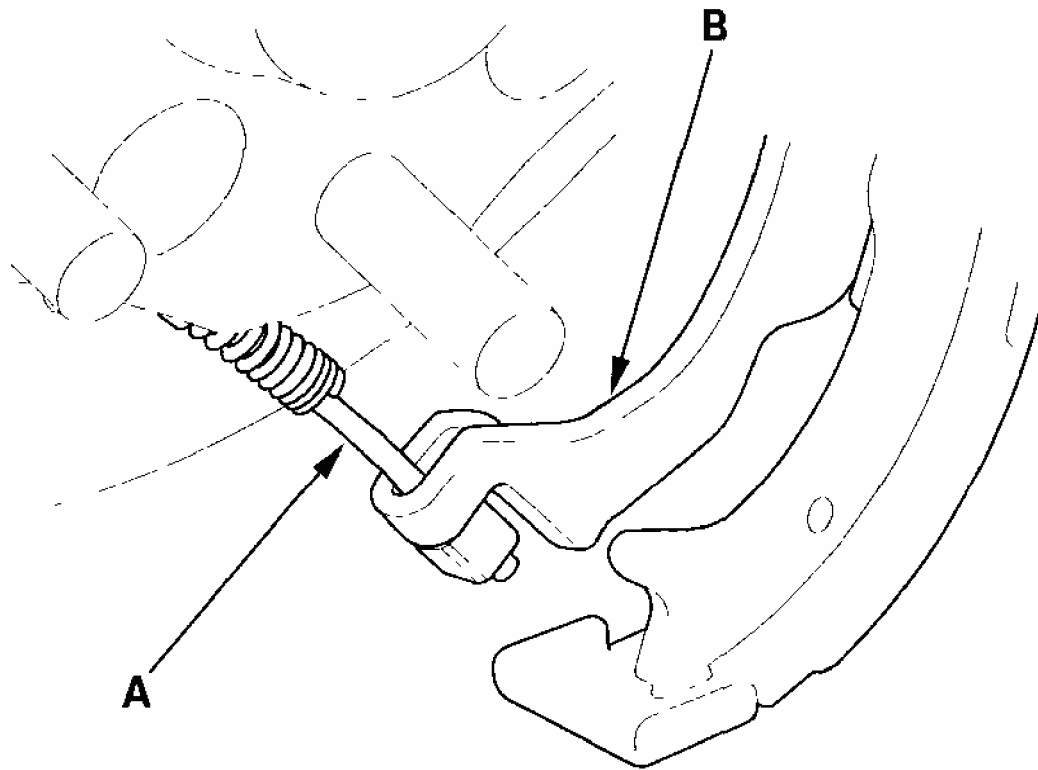

G03679207

Fig. 61: Disconnecting Parking Brake Cable From Parking Brake Lever
Courtesy of AMERICAN HONDA MOTOR CO., INC.

10. Remove the U-clip (A), wave washer (B), parking brake lever (C), and pivot pin (D) from the brake shoe.

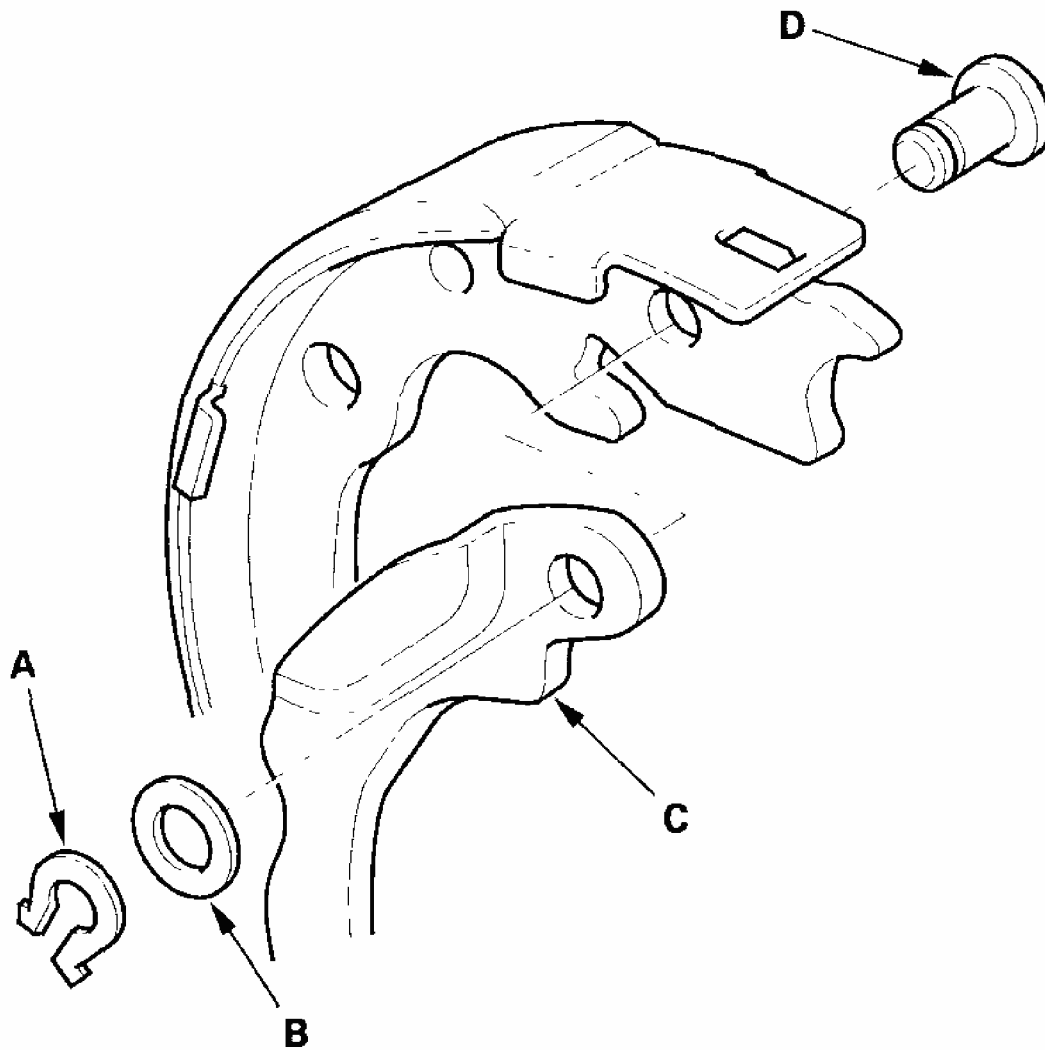

G03679208

Fig. 62: Removing U-Clip, Wave Washer, Parking Brake Lever, And Pivot Pin From Brake Shoe

Courtesy of AMERICAN HONDA MOTOR CO., INC.

REASSEMBLY

1. Apply a thin coat of 44 MA grease to the sliding surface of the pivot pin (A), and insert the pin into the rearward brake shoe (B).

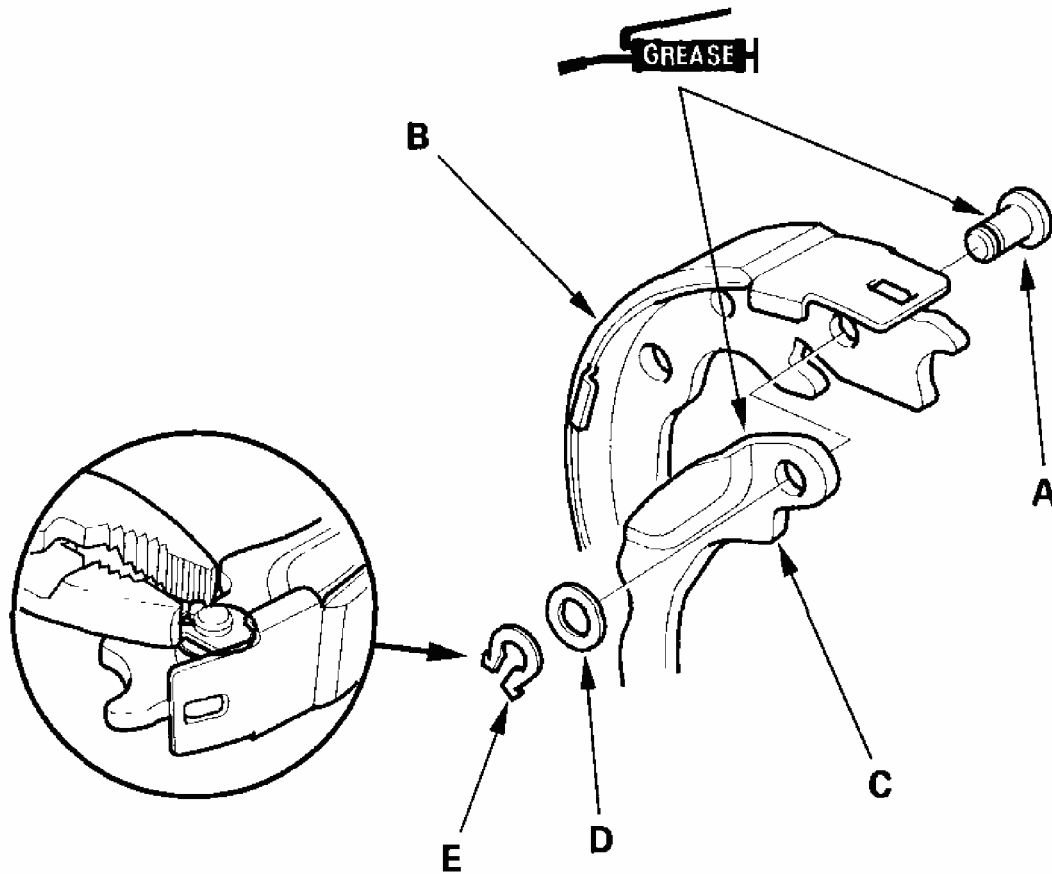

G03679209

Fig. 63: Applying Thin Coat Of 44 Ma Grease To Sliding Surface Of Pivot Pin
 Courtesy of AMERICAN HONDA MOTOR CO., INC.

2. Install the parking brake lever (C) and wave washer (D) on the pivot pin, and secure with a new U-clip (E).
 - Install the wave washer with its convex side facing out.
 - Pinch the U-clip securely to prevent the pivot pin from coming out of the brake shoe.
3. Connect the parking brake cable (A) to the parking brake lever (B). Apply silicone grease to the cable contact surface (C) on the backing plate.

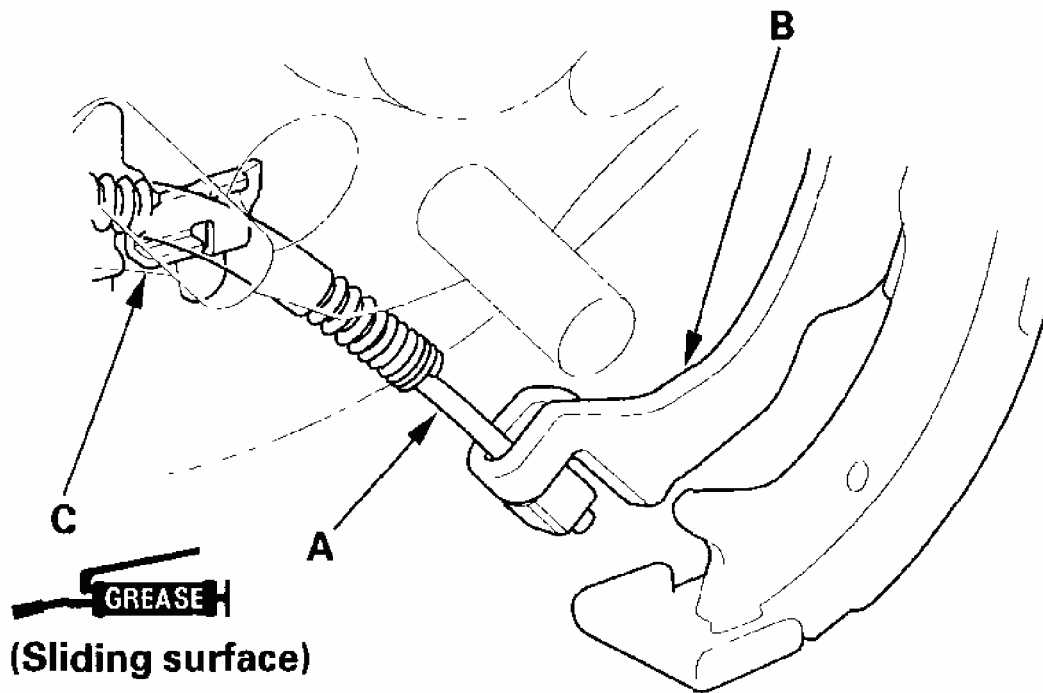

G03679210

Fig. 64: Connecting Parking Brake Cable To Parking Brake Lever
Courtesy of AMERICAN HONDA MOTOR CO., INC.

4. Apply a thin coat of 44 MA grease to the shoe ends and connecting rod ends (A), sliding surfaces (B), and opposite edges of the parking brake shoe (C) as illustrated. Wipe off any excess. Keep grease off the brake linings.

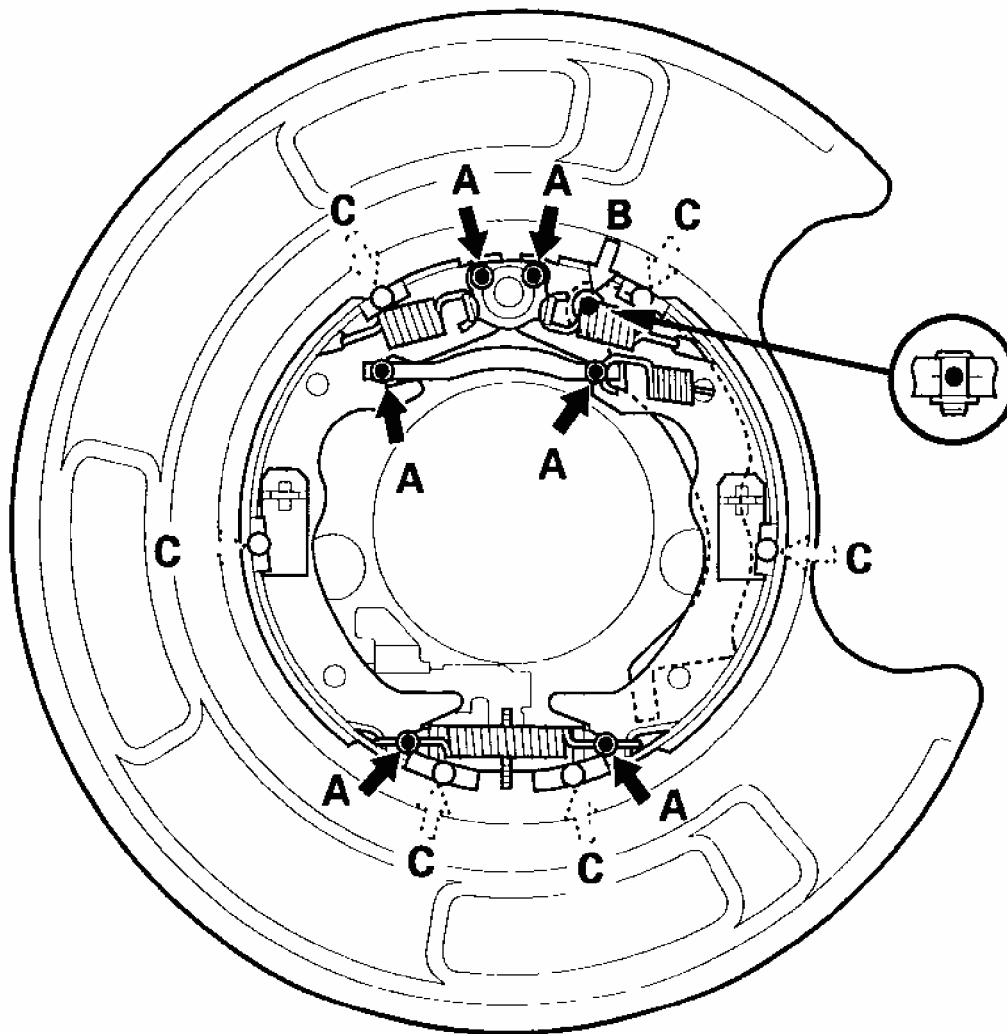

Greasing symbols:

- ➡● **Brake shoe ends and connecting rod ends**
- ⋯○ **Opposite edge of the shoe**
- ⇒● **Sliding surface**

G03679211

Fig. 65: Applying Coat Of Grease To Shoe Ends
 Courtesy of AMERICAN HONDA MOTOR CO., INC.

5. Clean the threaded portions of clevis A, and coat the threads of the clevis with grease. Clean the sliding surface of clevis B, and coat the sliding surface with multipurpose grease. Install the clevis A and B on the adjuster (C), and shorten clevis A by turning the adjuster.

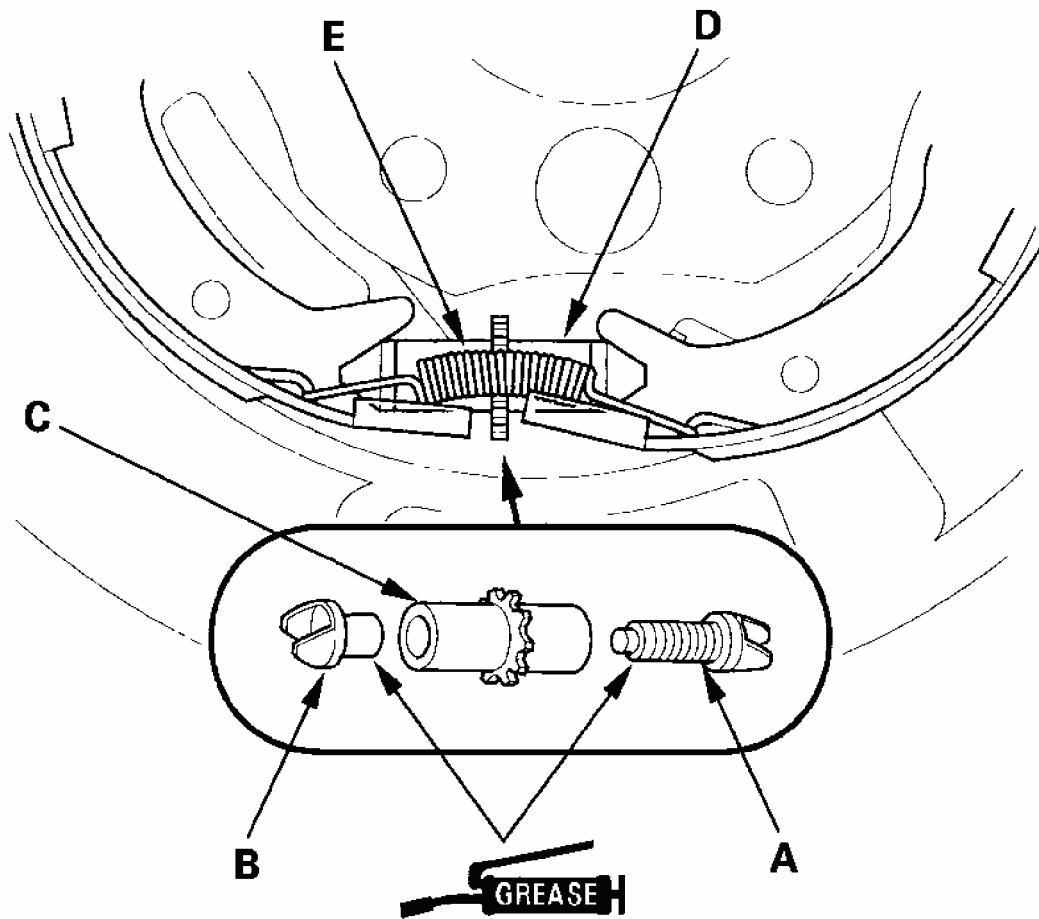

G03679212

Fig. 66: Cleaning Threaded Portions Of Clevis
 Courtesy of AMERICAN HONDA MOTOR CO., INC.

6. Reinstall the brake shoe adjuster assembly (D), and hook the lower return spring (E) on the parking brake shoes.
7. Hook the rod spring (A) to the connecting rod (B) first with the spring end (C) pointing downward. Then hook the rod spring to the parking brake shoe, and install the connecting rod on the parking brake shoes.

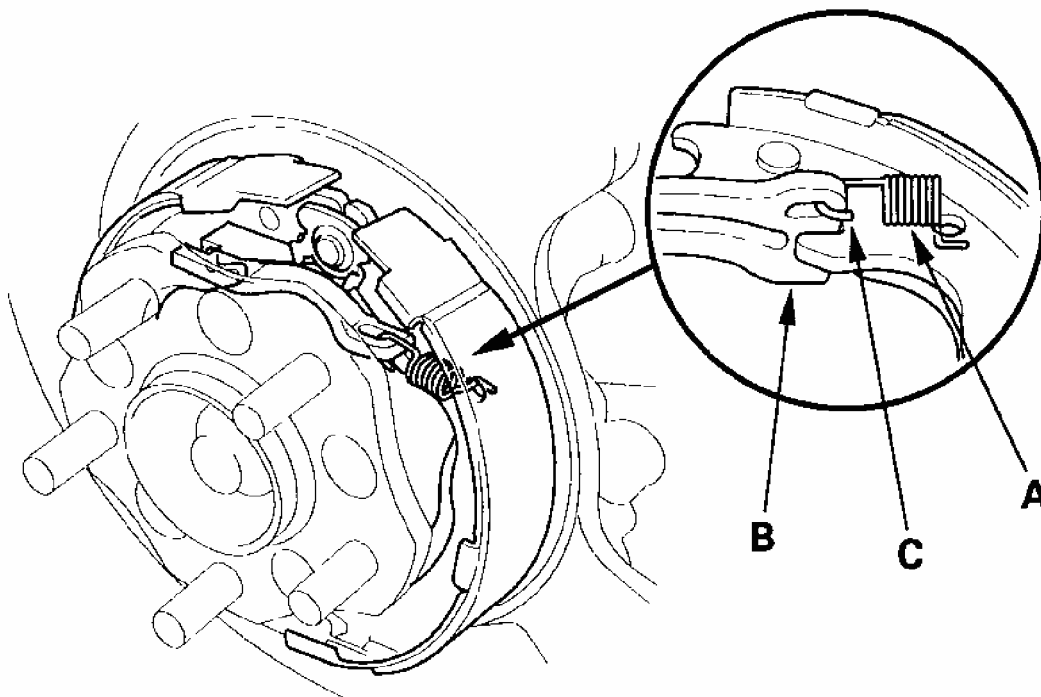

G03679213

Fig. 67: Reinstalling Brake Shoe

Courtesy of AMERICAN HONDA MOTOR CO., INC.

8. Reinstall the tension pins (A) and retainer springs (B). Make sure the tension pin does not contact the parking brake lever.

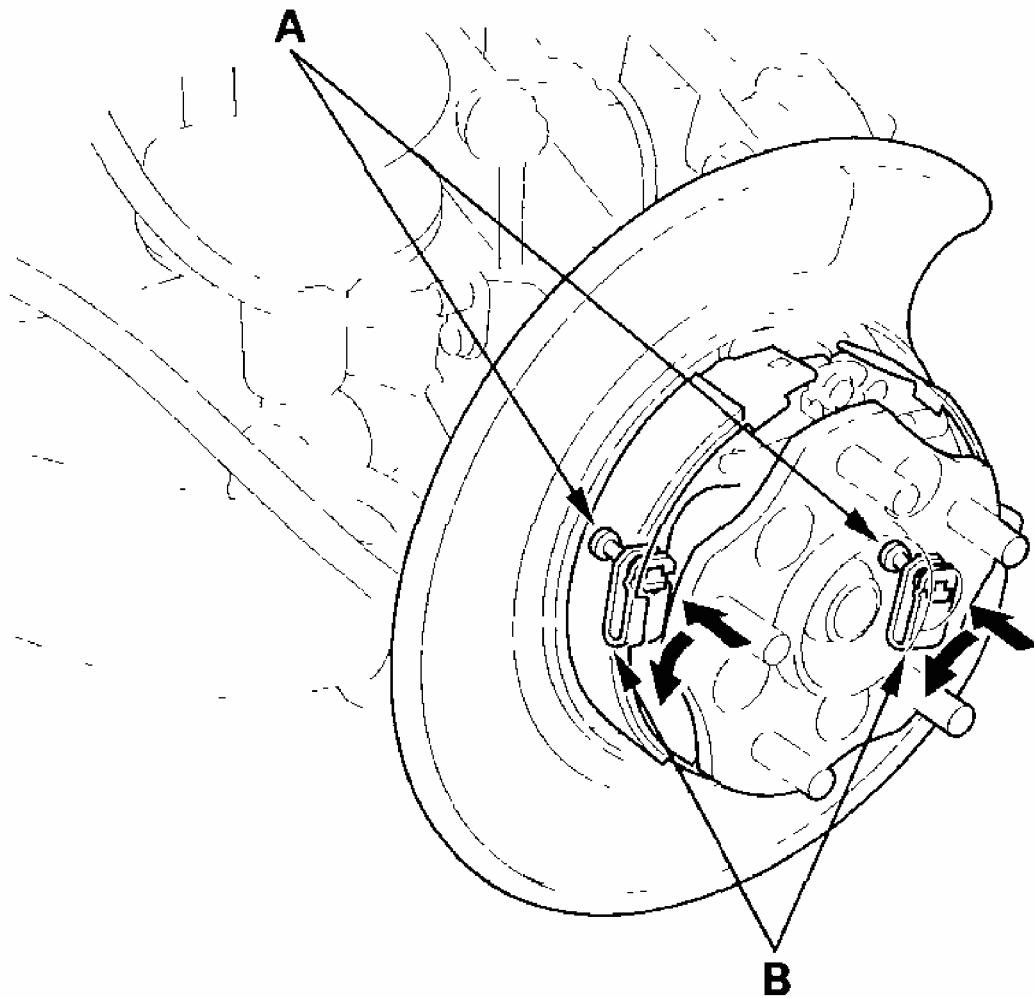

G03679214

Fig. 68: Reinstalling Tension Pins And Retainer Springs
Courtesy of AMERICAN HONDA MOTOR CO., INC.

9. Reinstall the upper return springs (A).

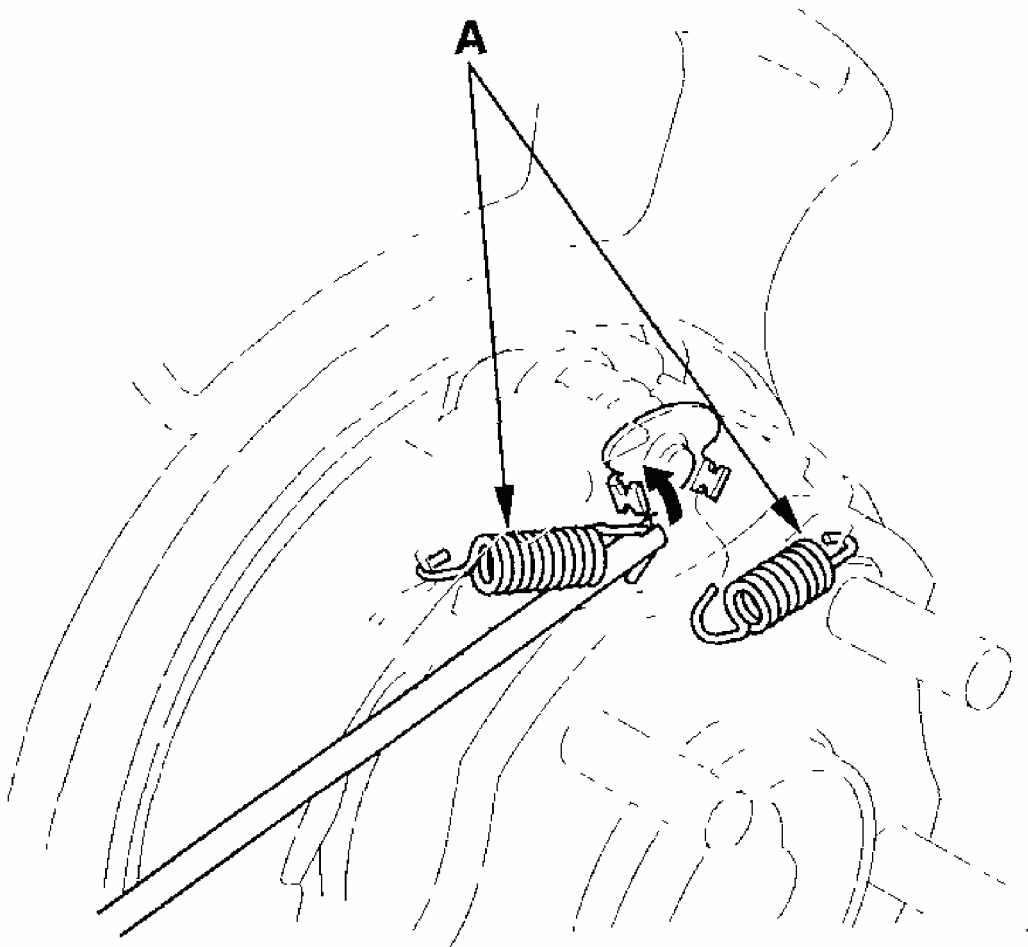

G03679215

Fig. 69: Reinstalling Upper Return Springs (A)
Courtesy of AMERICAN HONDA MOTOR CO., INC.

10. Install the rear brake disc/drum and rear brake caliper (see KNUCKLE/HUB/WHEEL BEARING REPLACEMENT).
11. Do the major adjustment for the parking brake (see MINOR ADJUSTMENT .

PARKING BRAKE SHOE LINING BREAK-IN

NOTE: Do the brake linings surface brake-in when replacing shoes with new linings and/or new rear brake disc/drum.

WARNING: Do this operation in a safe area.

1. Park the vehicle on a firm, level surface.
2. Do the major parking brake adjustment.
3. Do the minor parking brake adjustment.
4. Drive the vehicle at 31 mph (50 km/h).
5. Pull the parking brake lever 2 to 4 clicks while driving the vehicle for 400 m (1/4 mile).

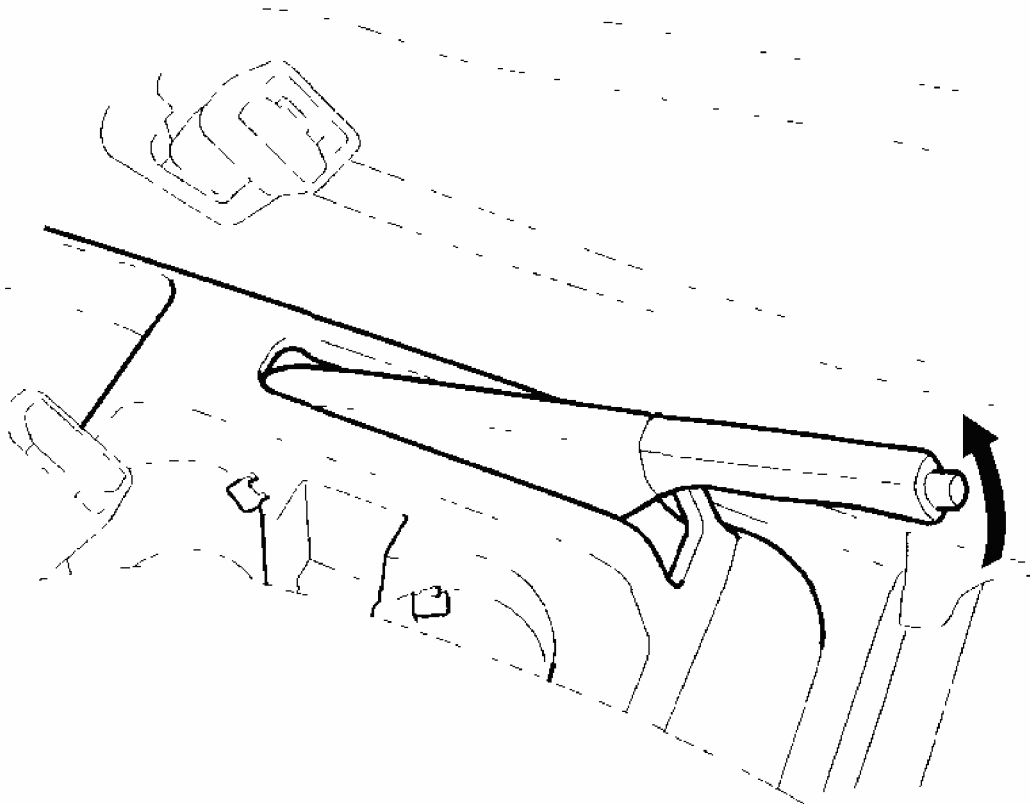

G03679216

Fig. 70: Pulling The Parking Brake Lever 2 To 4 Clicks
Courtesy of AMERICAN HONDA MOTOR CO., INC.

6. Stop the vehicle, and release the parking brake lever for 5-10 minutes to allow the rear brake disc/drum to cool.
7. Repeat steps 4 through 6 three more times.
8. Check the parking brake lever adjustment (see)**PEDAL FREE PLAY** .

BRAKE PEDAL REPLACEMENT

1. Remove the clip (A) and pin (B).

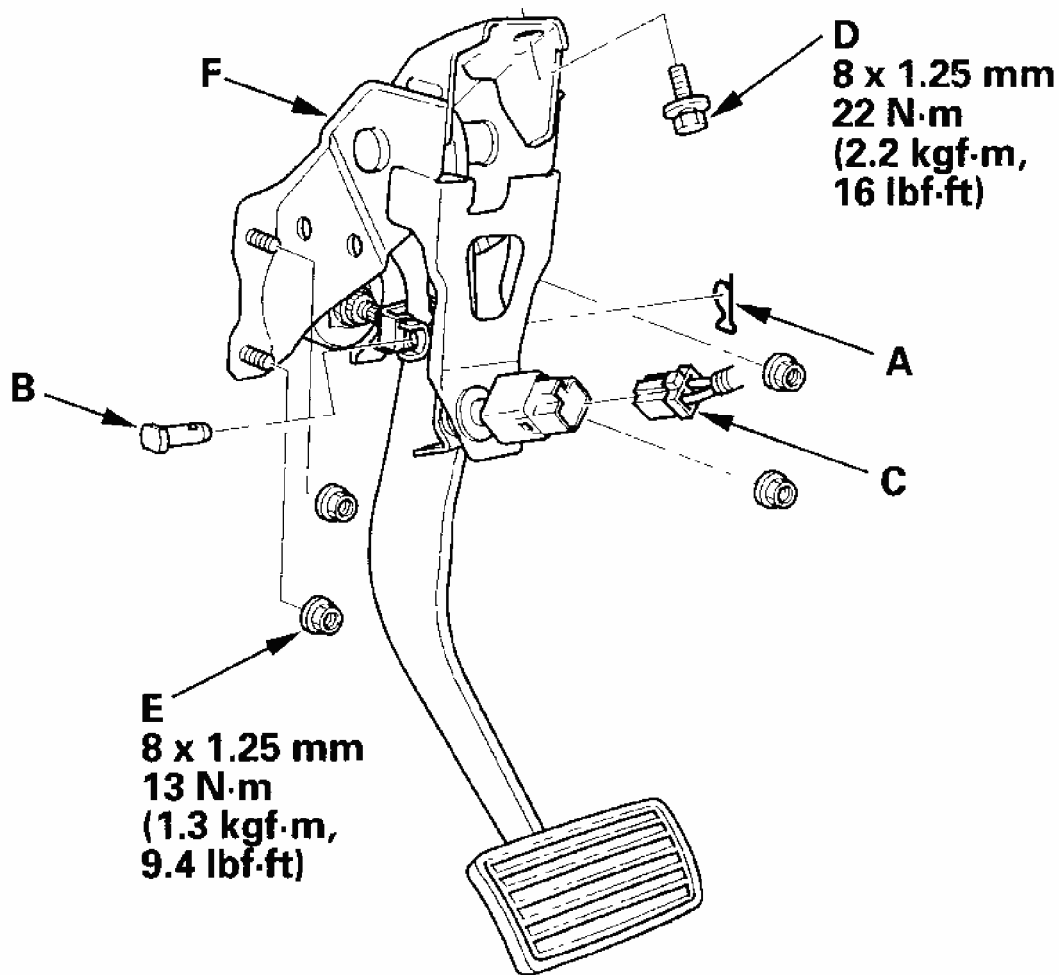

G03679217

Fig. 71: Removing Clip And Pin With Torque Specifications
 Courtesy of AMERICAN HONDA MOTOR CO., INC.

2. Disconnect the brake pedal position switch connector (C).
3. Remove the brake pedal bracket mounting bolt (D) and brake booster mounting nuts (E).
4. Remove the brake pedal with bracket (F).
5. Install in the reverse order of removal.
6. Do the brake pedal and brake pedal position switch adjustment (see)**BRAKE PEDAL AND BRAKE PEDAL POSITION SWITCH ADJUSTMENT** .

BRAKE HOSE AND LINE INSPECTION

1. Inspect the brake hoses for damage, deterioration, leaks, interference, and twisting.

2004 Honda Element DX

2003-06 BRAKES Conventional Brake Components - Element

2. Check the brake lines for damage, rusting, and leaks. Also check for bent brake lines.
3. Check for leaks at hose and line joints and connections, and retighten if necessary.
4. Check the master cylinder and ABS modulator-control unit (if equipped) for damage and leaks.

NOTE: Replace the brake hose clip whenever the brake hose is serviced.

Connection Point	Component	Connected to	Specified Torque Value	Note
A	Front brake caliper	Brake hose	34 N·m (3.5 kgf·m, 25 lbf·ft)	Banjo bolt
		Bleed screw	8.0 N·m (0.8 kgf·m, 6.0 lbf·ft)	
B	Rear brake caliper	Brake hose	34 N·m (3.5 kgf·m, 25 lbf·ft)	Banjo bolt
		Bleed screw	8.0 N·m (0.8 kgf·m, 6.0 lbf·ft)	
C	Brake hose	Brake line	15 N·m (1.5 kgf·m, 11 lbf·ft)	Flare nut
D	Master cylinder	Brake line	15 N·m (1.5 kgf·m, 11 lbf·ft)	Flare nut
E	ABS modulator-control unit	Brake line (10 mm nut)	15 N·m (1.5 kgf·m, 11 lbf·ft)	Flare nut

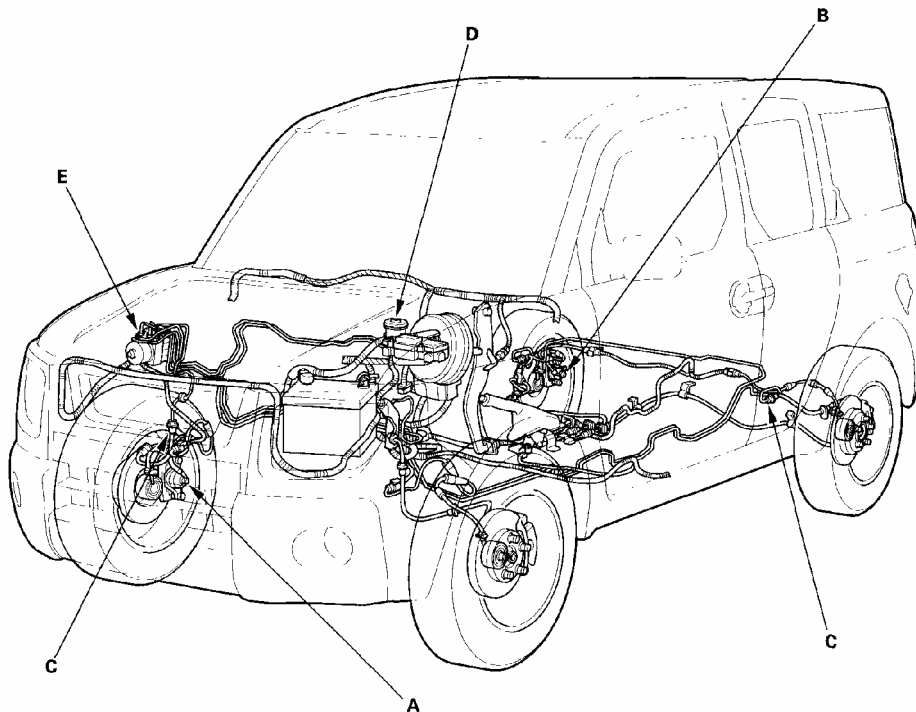

G03679218

Fig. 72: Locating Brake Hose And Line Components With Torque Specifications
Courtesy of AMERICAN HONDA MOTOR CO., INC.

BRAKE HOSE REPLACEMENT

NOTE:

- Do not spill brake fluid on the vehicle; it may damage the paint; if brake fluid gets on the paint, wash it off immediately with water.
- To prevent dripping, cover disconnected line joints with rags or shop towels.

- Before reassembling, check that all parts are free of dust and other foreign particles.
- Replace parts with new ones whenever specified to do so.

1. Replace the brake hose (A) if the hose is twisted, cracked, or leaking.

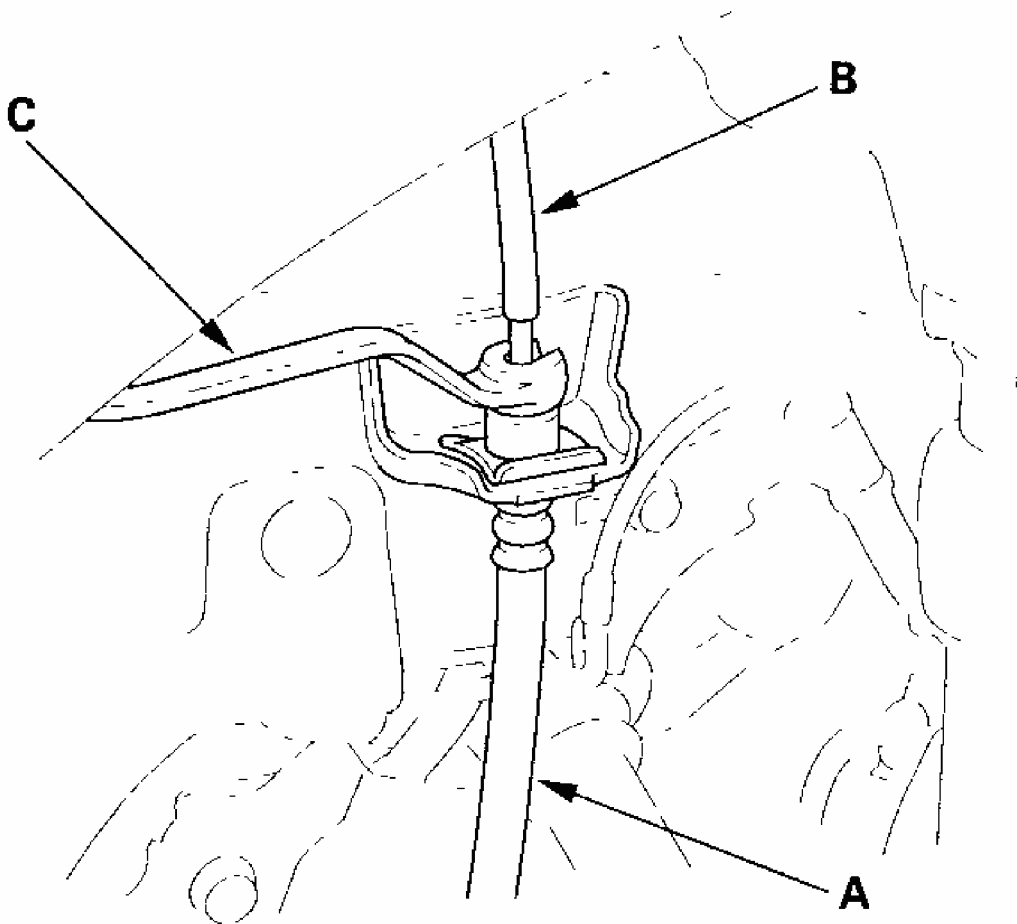

G03679219

Fig. 73: Replacing Twisted Brake Hose

Courtesy of AMERICAN HONDA MOTOR CO., INC.

2. Disconnect the brake hose from the brake line (B) using a 10 mm flare-nut wrench (C).
3. Remove the flange bolt (A), and remove the brake hose brackets from the damper.

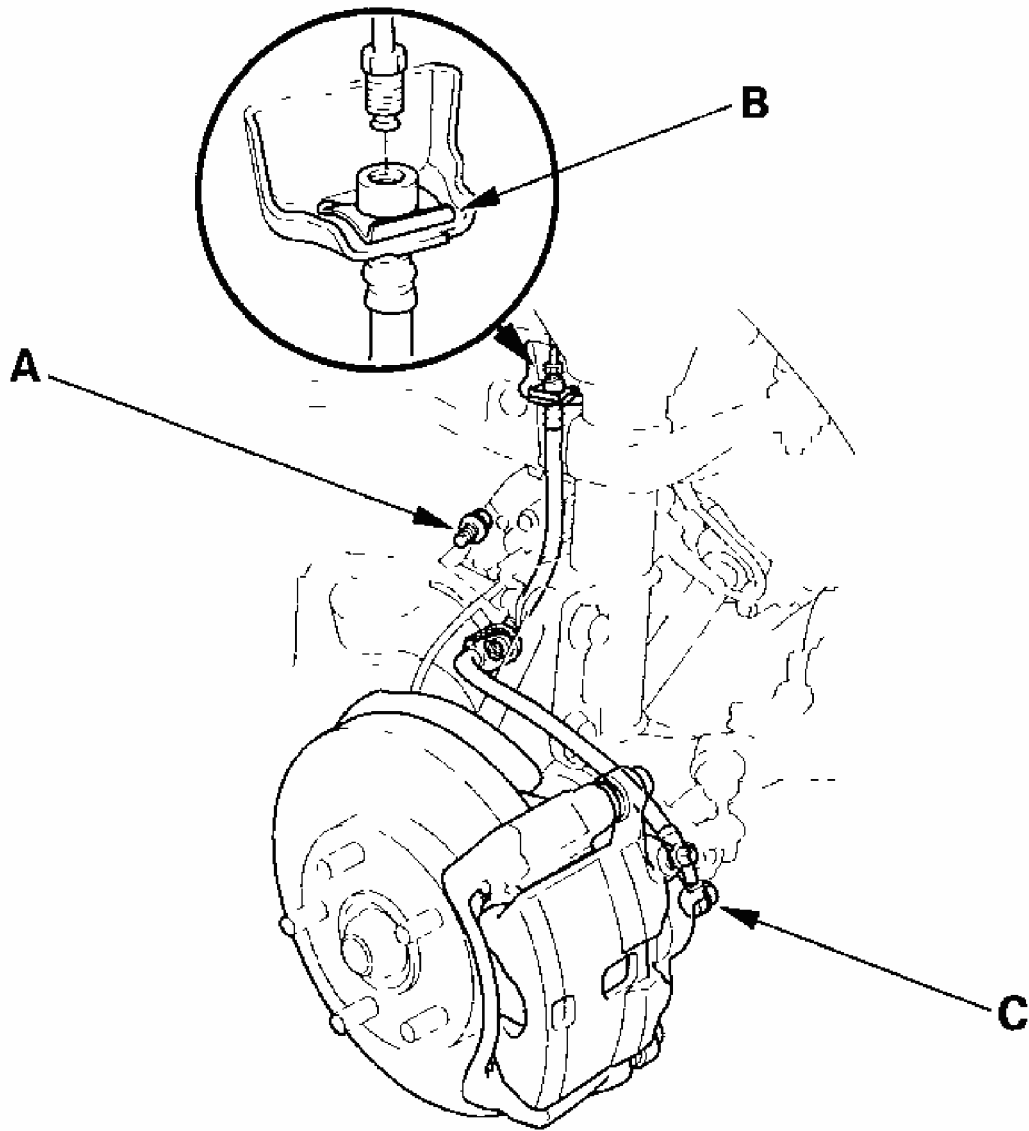

G03679220

Fig. 74: Removing Flange Bolt And Brake Hose Brackets From Damper
Courtesy of AMERICAN HONDA MOTOR CO., INC.

4. Remove and discard the hose clip (B).
5. Remove the banjo bolt (C), and remove the brake hose from the caliper.
6. Install the brake hose bracket (A) on the damper with the flange bolt (B) first, then connect the brake hose to the caliper with the banjo bolt (C) and new sealing washers (D).

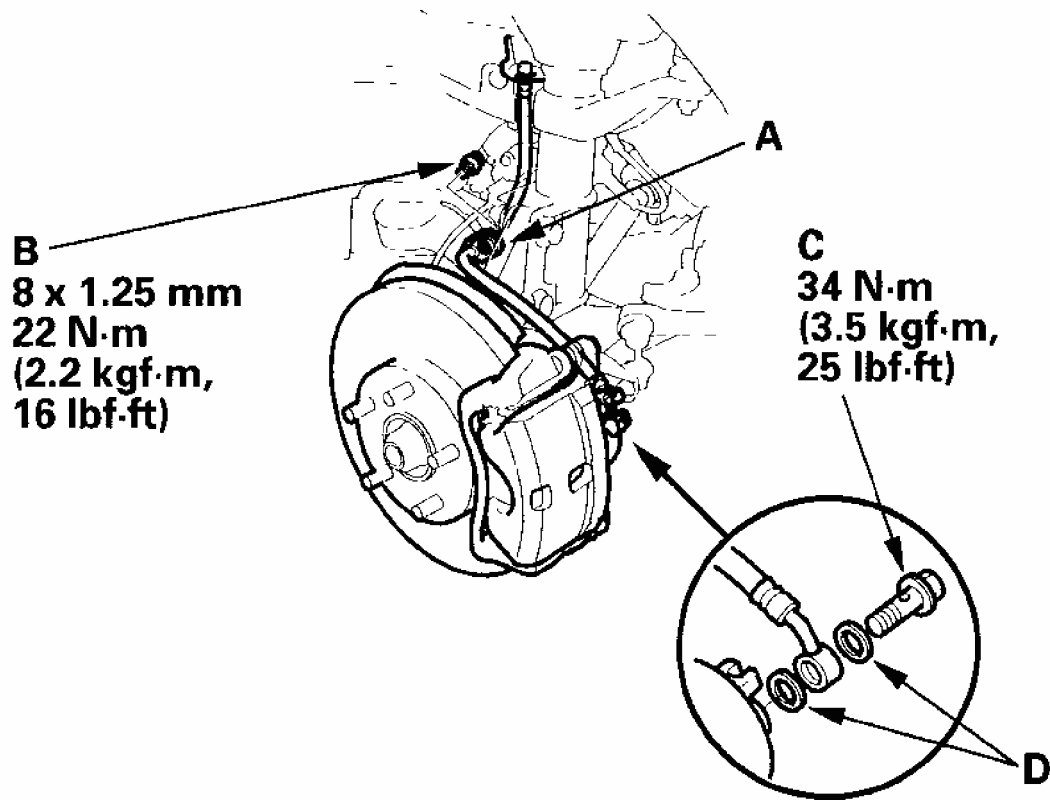

G03679221

Fig. 75: Connecting Brake Hose To Caliper With Banjo Bolt And Torque Specifications

Courtesy of AMERICAN HONDA MOTOR CO., INC.

7. Install the brake hose onto the brake hose bracket on the body with a new hose clip (A).

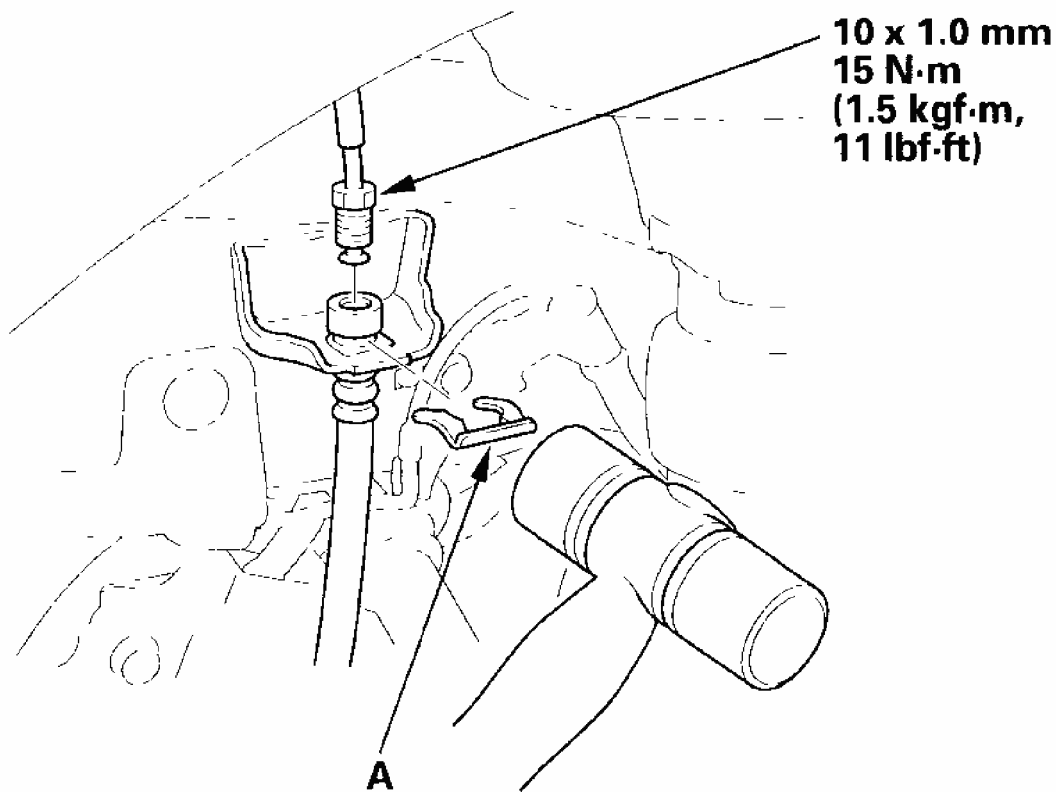

G03679222

Fig. 76: Installing Brake Hose Onto Brake Hose Bracket And Torque Specifications

Courtesy of AMERICAN HONDA MOTOR CO., INC.

8. Connect the brake line to the brake hose.
9. After installing the brake hose, bleed the brake system)**BRAKE SYSTEM BLEEDING** .
10. Do the following checks:
 - Check the brake hose and line joint for leaks, and tighten if necessary.
 - Check the brake hoses for interference and twisting.

PARKING BRAKE CABLE REPLACEMENT

EXPLODED VIEW

2004 Honda Element DX

2003-06 BRAKES Conventional Brake Components - Element

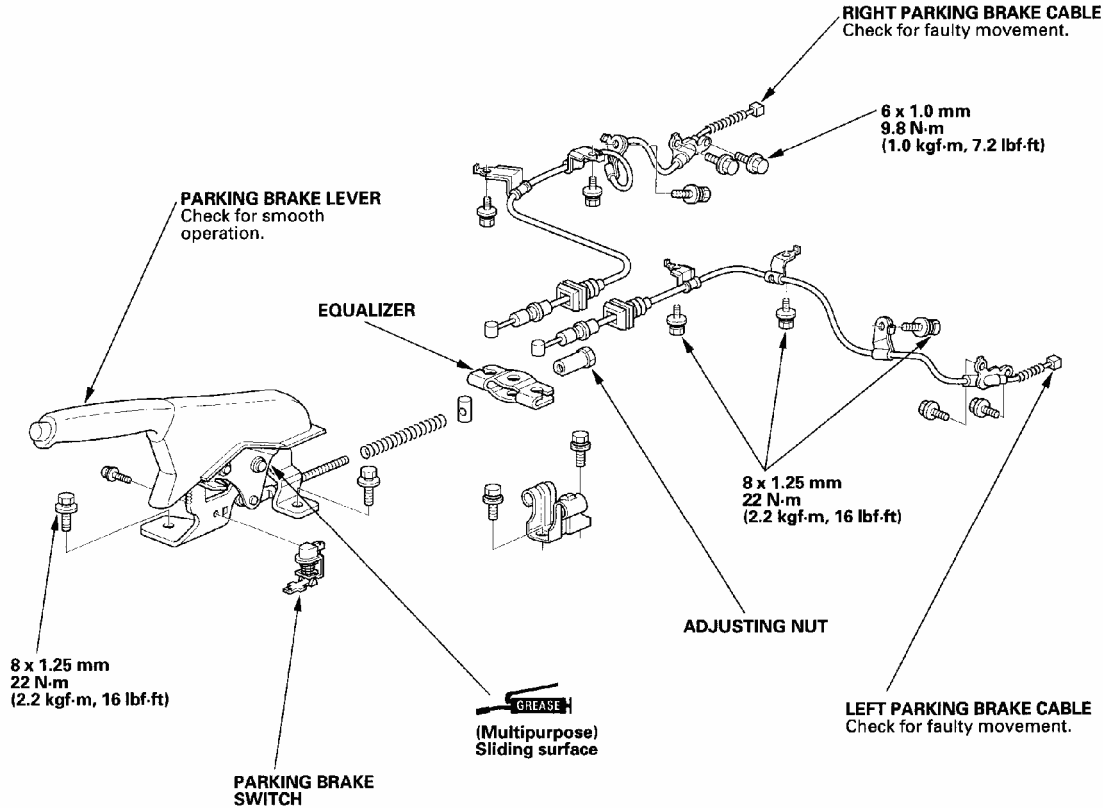
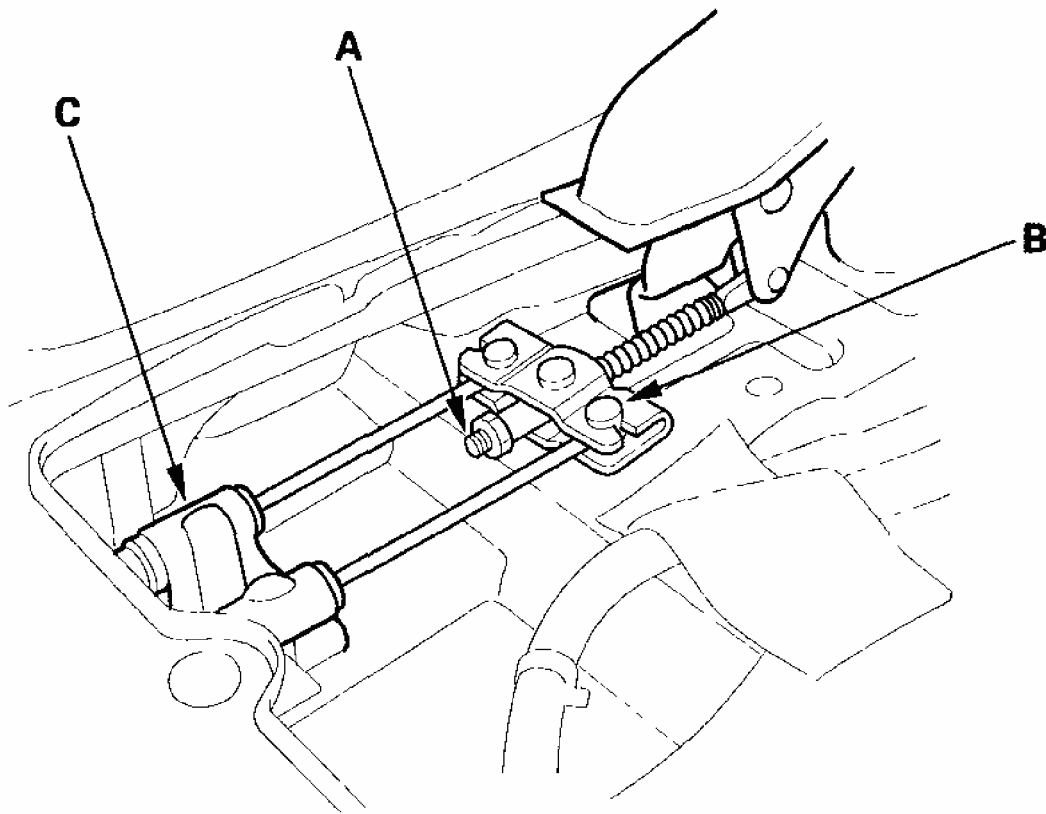

Fig. 77: Exploded View Of Parking Brake Cable And Torque Specifications
Courtesy of AMERICAN HONDA MOTOR CO., INC.

NOTE: The parking brake cables must not be bent or distorted. This will lead to stiff operation and premature failure.

Refer to the **EXPLODED VIEW** as needed during this procedure.

1. Raise the rear of the vehicle, and support it with safety stands in the proper locations (see **SAFETY STANDS**).
2. Remove the rear wheels.
3. Release the parking brake lever fully.
4. Remove the center console (see **CENTER CONSOLE REMOVAL/INSTALLATION**).
5. Back off the adjusting nut (A) in the equalizer, and disconnect the parking brake cable ends (B) from the equalizer.



G03679224

Fig. 78: Disconnecting Parking Brake Cable Ends
Courtesy of AMERICAN HONDA MOTOR CO., INC.

6. Remove the cable guide base (C).
7. Remove the rear brake shoe (see)**PARKING BRAKE SHOE REPLACEMENT** , and disconnect the parking brake cable from the shoe.
8. Remove the flange bolts (A) and parking brake cable (B) from the backing plate (C).

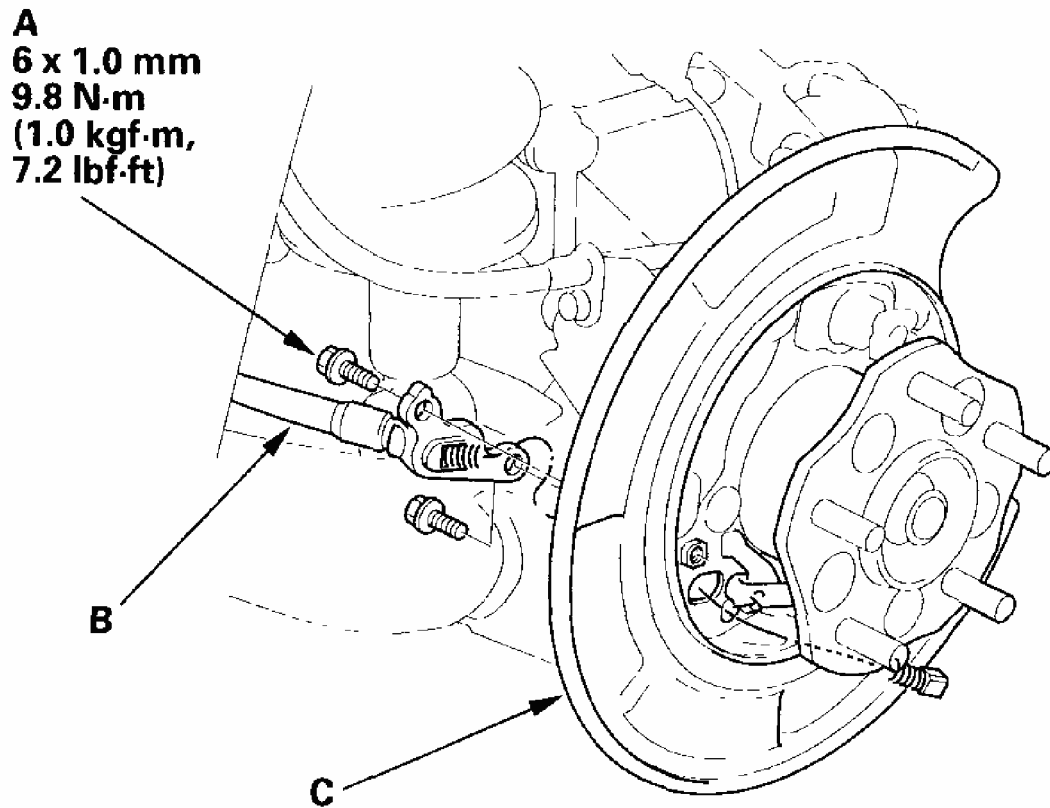

G03679225

Fig. 79: Removing Flange Bolts And Parking Brake Cable From Backing Plate With Torque Specifications

Courtesy of AMERICAN HONDA MOTOR CO., INC.

9. Reinstall the parking brake cable in the reverse order of removal, and note these items:
 - Be careful not to bend or distort the cable.
 - Tighten adjusting nut in the equalizer until there is tension in the wires.
 - Apply and release the hand brake lever fully 10 times.
 - Do the major parking brake adjustment **MINOR ADJUSTMENT** .