

2003-06 SUSPENSION

Rear Suspension - Element

KNUCKLE/HUB/WHEEL BEARING REPLACEMENT

EXPLODED VIEW

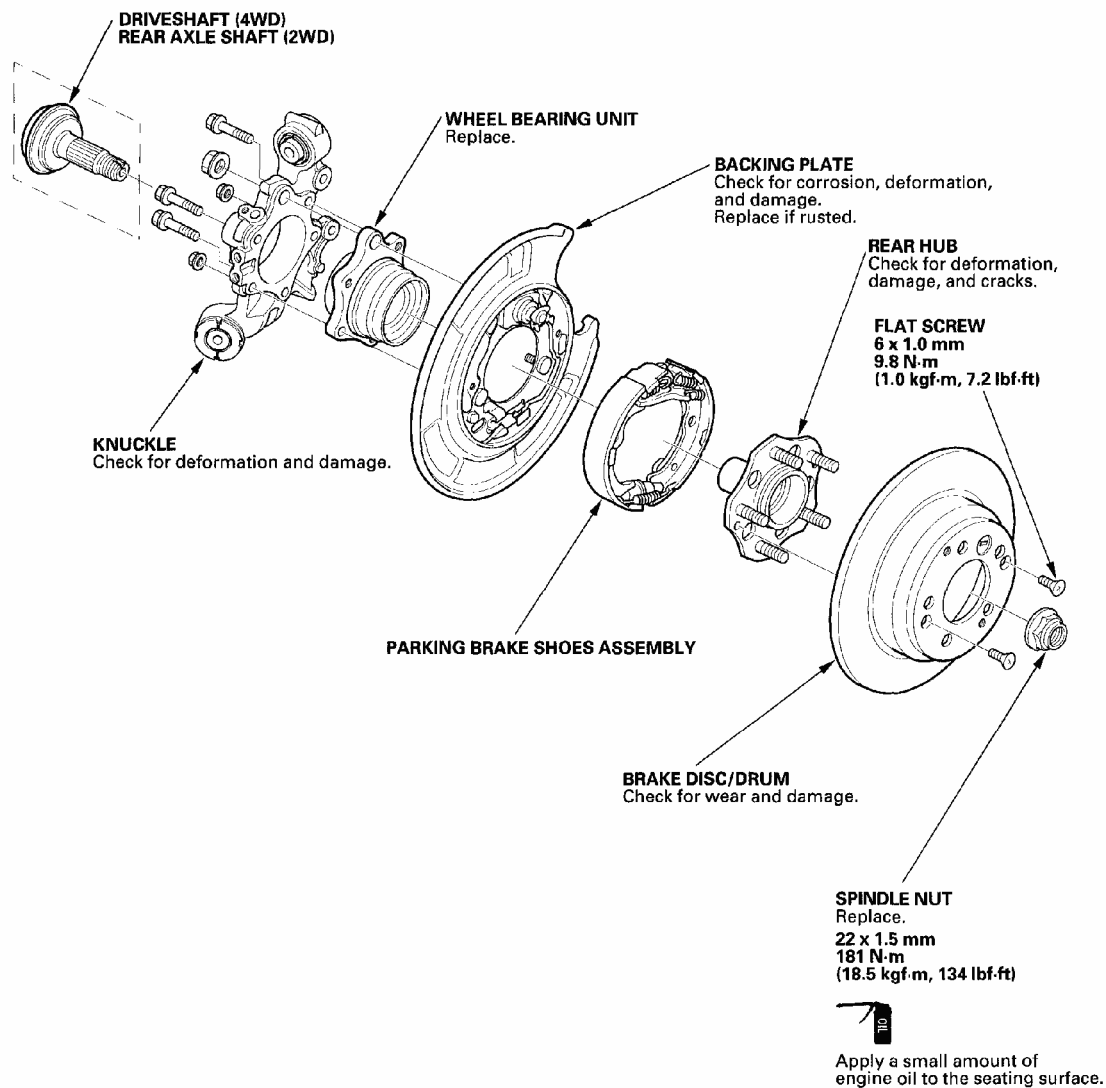

G03679107

Fig. 1: Exploded View Of Knuckle/Hub/Wheel Bearing
Courtesy of AMERICAN HONDA MOTOR CO., INC.

Special Tools Required

- Hub dis/assembly tool 07965-SA70100
- Attachment, 62 x 68 mm 07746-0010500
- Driver 07749-0010000

- Support base 07965-SD90100

KNUCKLE REPLACEMENT

1. Raise the rear of the vehicle, and support it with safety stands in the proper locations (see **SAFETY STANDS**).
2. Remove the wheel nuts and rear wheel.

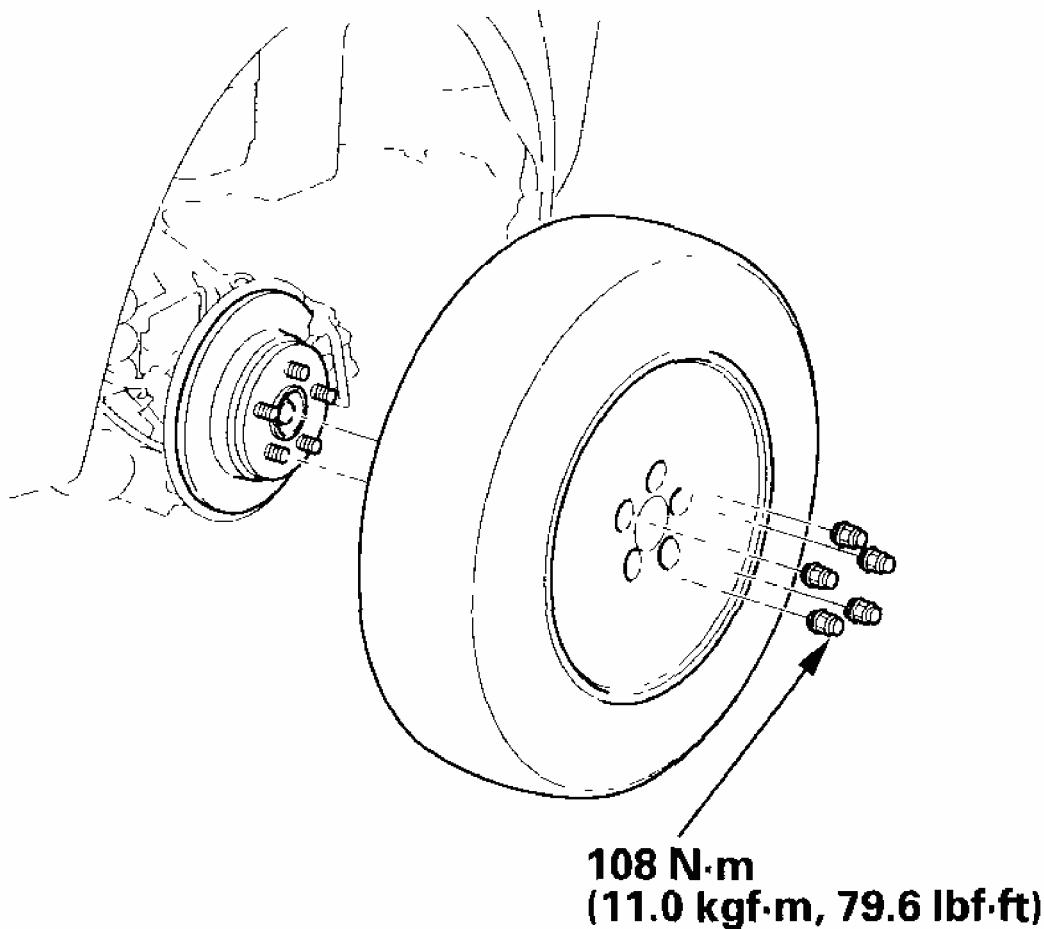

G03679108

Fig. 2: Removing Wheel Nuts And Rear Wheel And Torque Specifications
Courtesy of AMERICAN HONDA MOTOR CO., INC.

3. Release the parking brake lever.
4. Remove the brake hose mounting bolt (A).

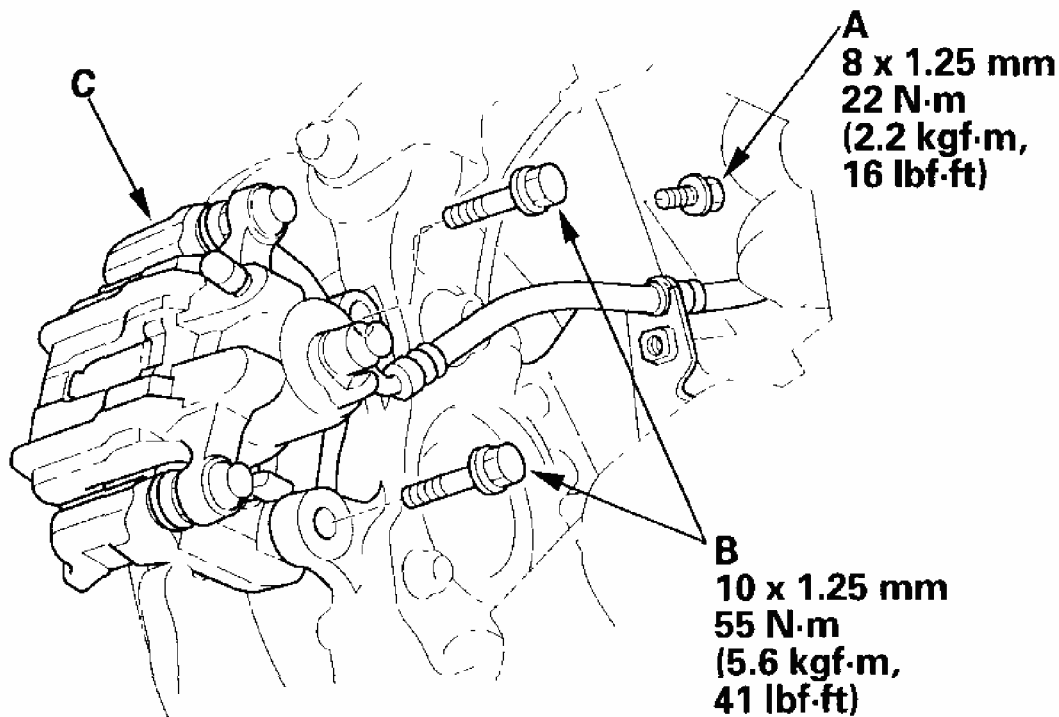

G03679109

Fig. 3: Removing Brake Hose Mounting Bolt And Torque Specifications
Courtesy of AMERICAN HONDA MOTOR CO., INC.

5. Remove the caliper bracket mounting bolts (B), and hang the caliper (C) to one side. To prevent damage to the caliper or brake hose, use a short piece of wire to hang the caliper from the undercarriage.
6. Remove the brake disc retaining flat screw (A), and screw two 8 x 1.25 mm bolts into the brake disc/drum (B) to push it away from the hub. Turn each bolt two turns at a time to prevent cocking the brake disc/drum excessively. Remove the brake disc/drum.

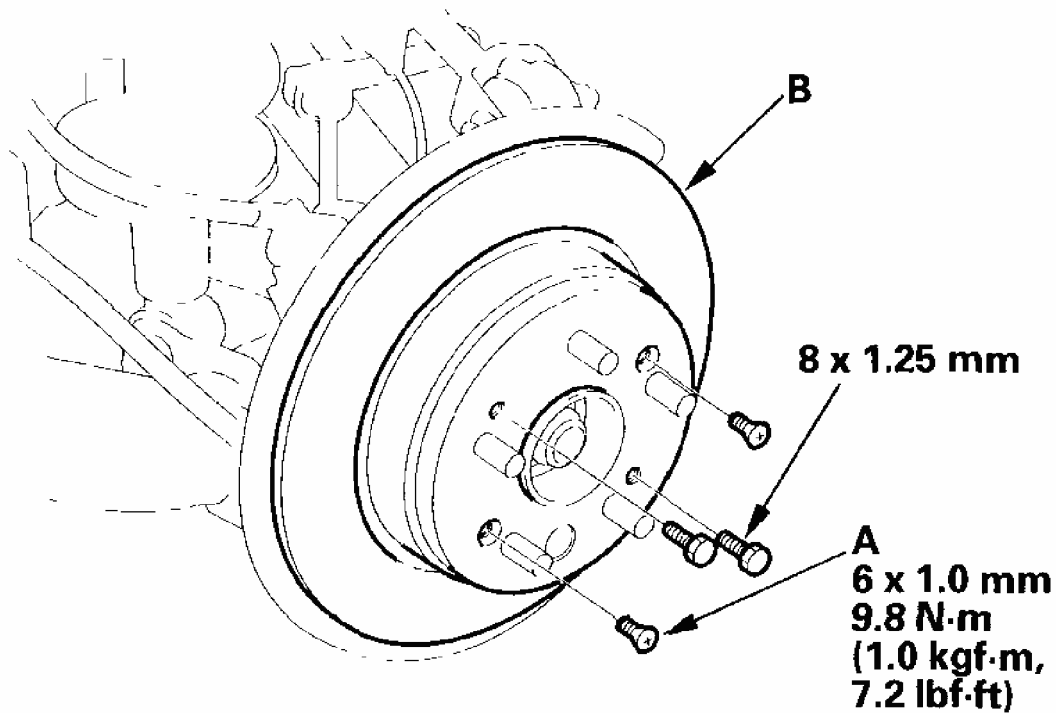

G03679110

Fig. 4: Removing Brake Disc/Drum And Torque Specifications
Courtesy of AMERICAN HONDA MOTOR CO., INC.

7. Raise the stake (A) of the spindle nut (B), then remove and discard the nut. Remove the rear axle shaft (C) from vehicles with 2WD.

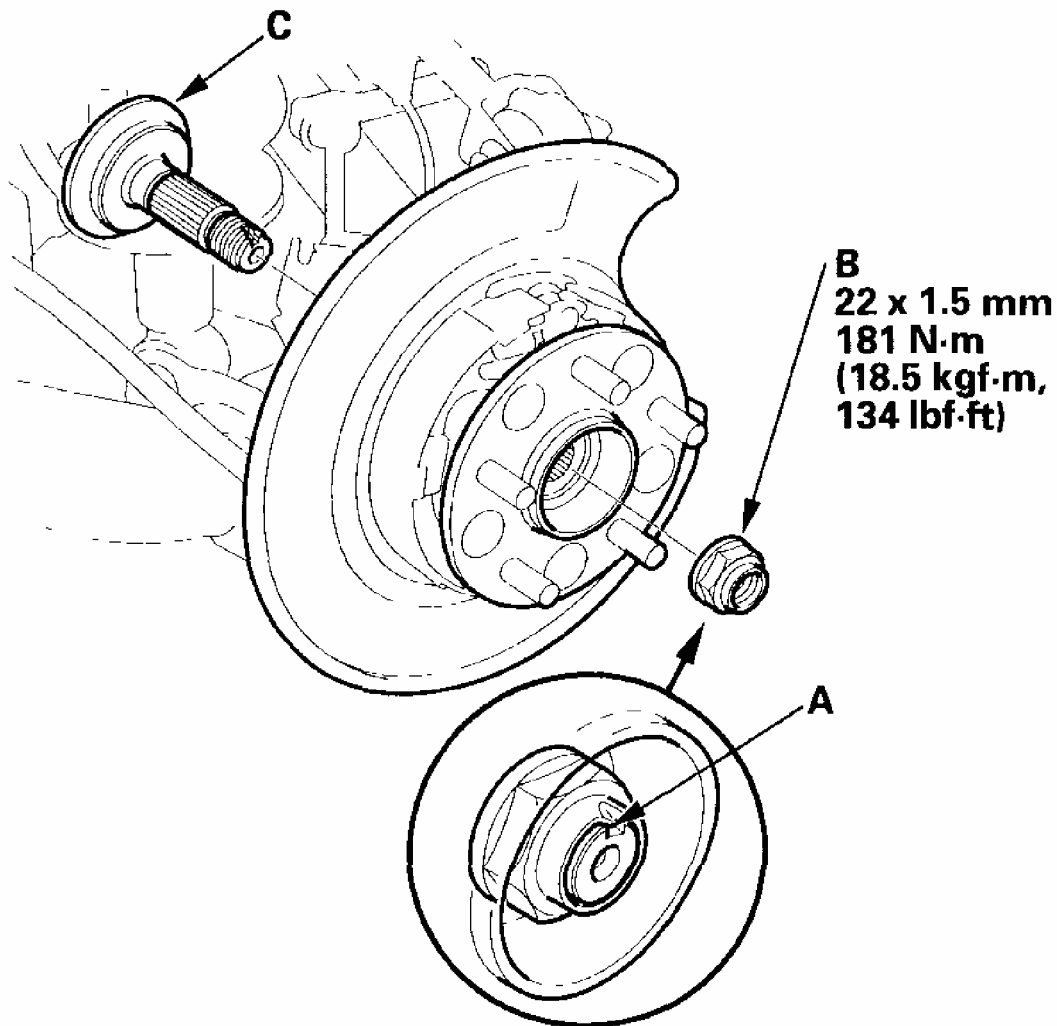

G03679111

Fig. 5: Raising Stake Of Spindle Nut And Torque Specifications
Courtesy of AMERICAN HONDA MOTOR CO., INC.

8. Remove the parking brake shoes (see **PARKING BRAKE SHOE REPLACEMENT**).
9. Remove the parking brake cable (A) from the backing plate.

NOTE: The parking brake cable must not be bent or distorted. This will lead to stiff operation and premature cable failure.

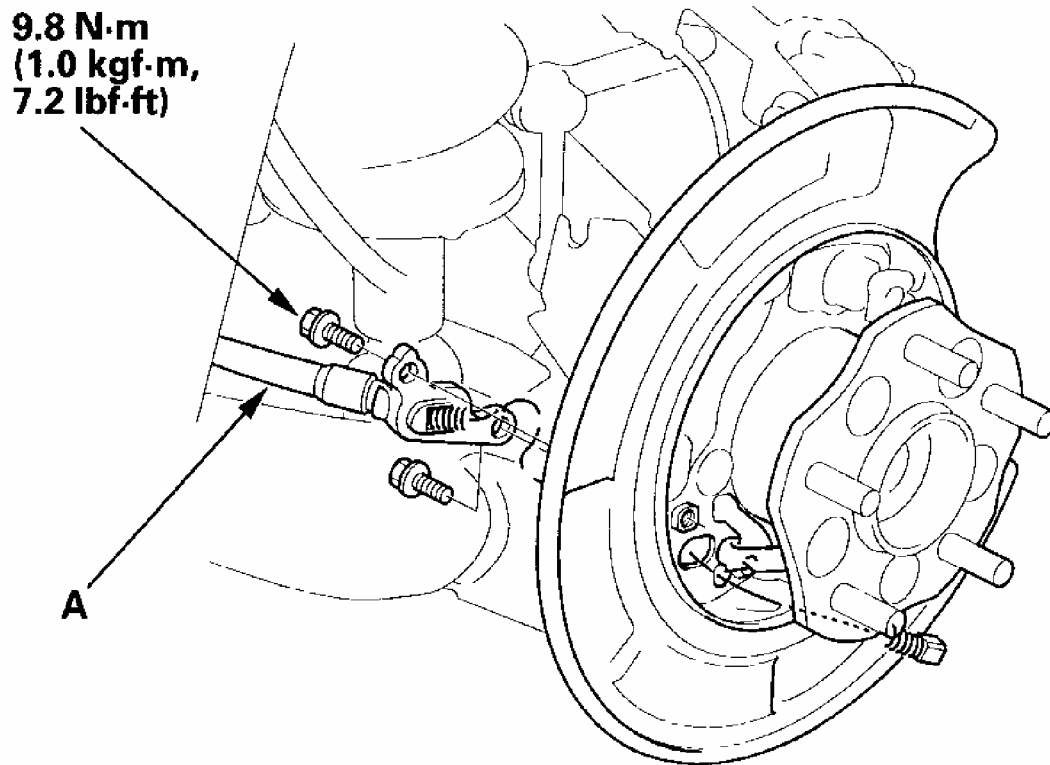

G03679112

Fig. 6: Removing Parking Brake Cable From Backing Plate And Torque Specifications
Courtesy of AMERICAN HONDA MOTOR CO., INC.

10. Remove the wheel sensor (A) from the knuckle (if equipped with ABS).

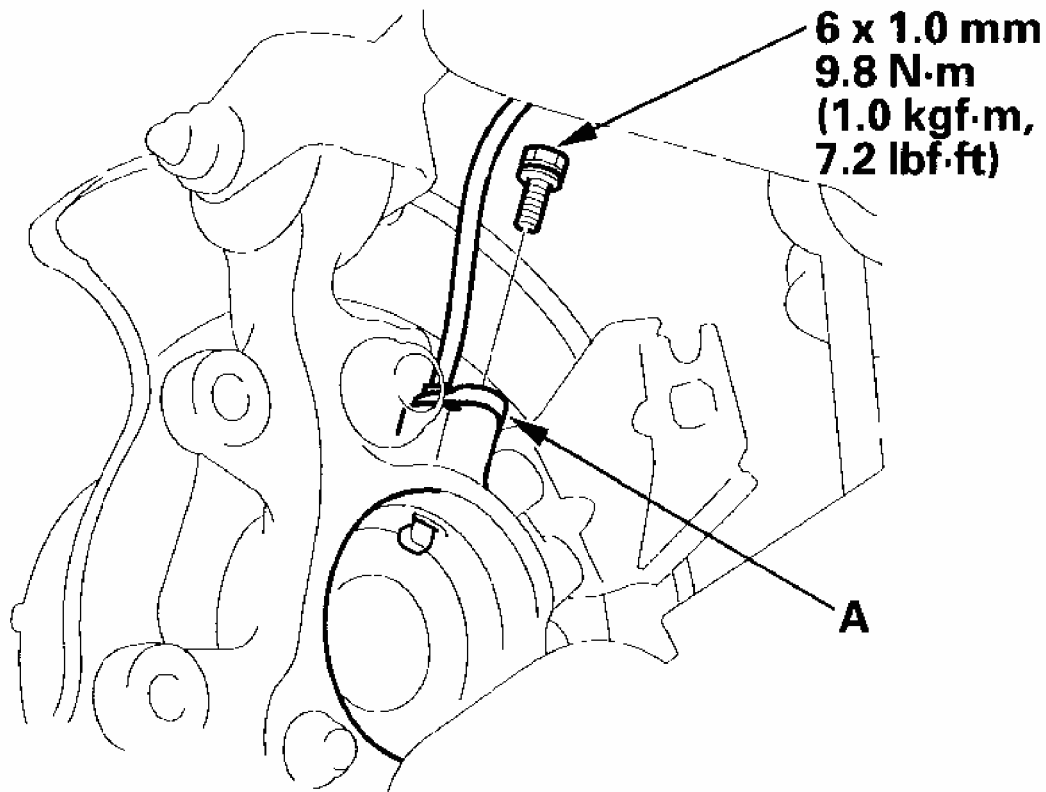

G03679113

Fig. 7: Removing Wheel Sensor From Knuckle And Torque Specifications
Courtesy of AMERICAN HONDA MOTOR CO., INC.

11. Place a floor jack under the trailing arm (A) to support it.

NOTE: Do not place the jack against the plate section of the lower arm. Be careful not to damage any suspension components.

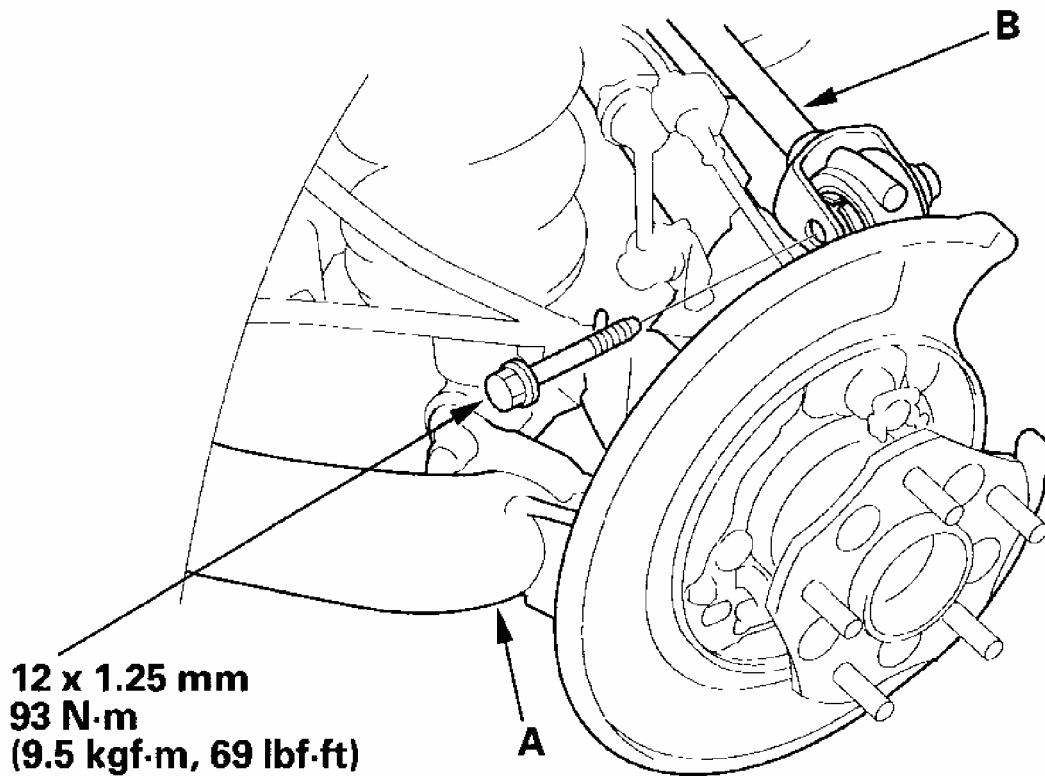

G03679114

Fig. 8: Placing Floor Jack Under Trailing Arm And Torque Specifications
Courtesy of AMERICAN HONDA MOTOR CO., INC.

12. Remove the flange bolt, and disconnect the upper arm (B) from the knuckle.
13. Mark the cam positions of the adjusting bolt (A) and adjusting cam (B), then remove the self-locking nut (C), adjusting cam, and adjusting bolt. Discard the self-locking nut.

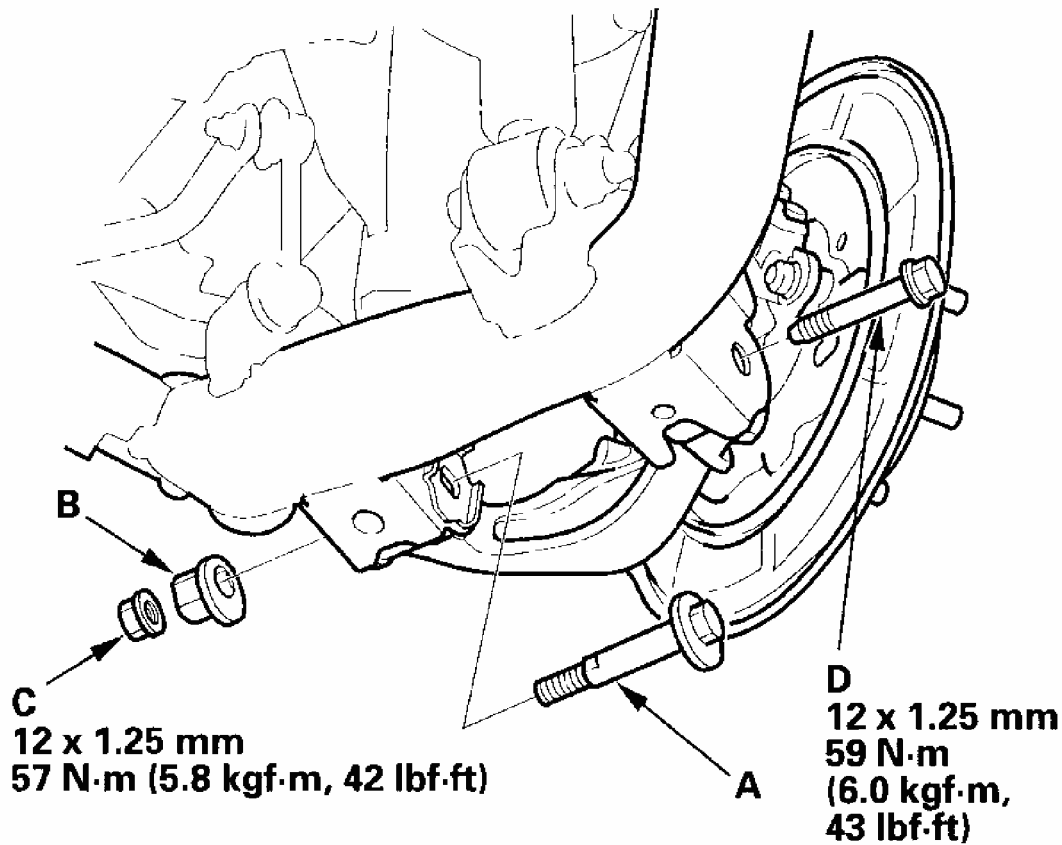

G03679115

Fig. 9: Removing Flange Bolt And Torque Specifications
Courtesy of AMERICAN HONDA MOTOR CO., INC.

14. Remove the flange bolt (D).
15. Remove the knuckle (A) while pushing in the driveshaft and holding the driveshaft outboard joint (B) (4WD only).

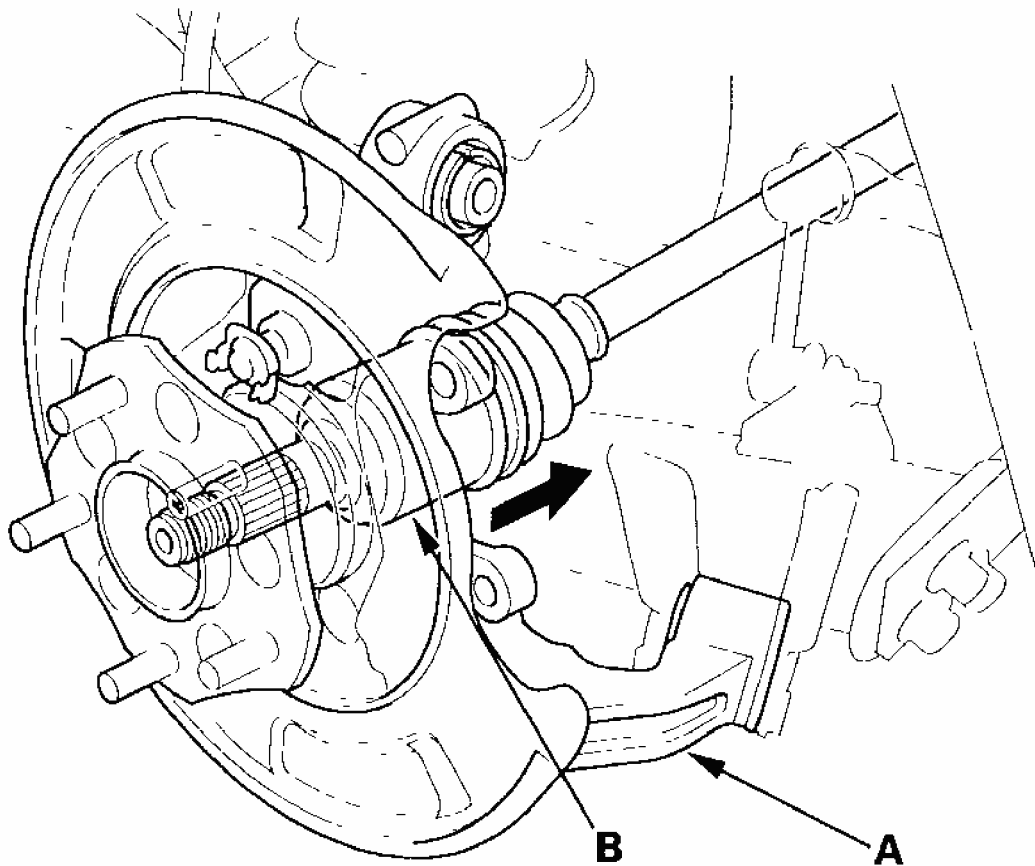

G03679116

Fig. 10: Removing Knuckle While Pushing In Driveshaft And Holding Driveshaft Outboard Joint

Courtesy of AMERICAN HONDA MOTOR CO., INC.

16. Install the knuckle in the reverse order of removal, and note these items:
- First install all the suspension components, and lightly tighten the bolts and nuts, then place a floor jack under the trailing arm, and raise the suspension to load it with the vehicle's weight before fully tightening the bolts and nuts to the specified torque values.
 - Align the cam positions of the adjusting bolt and adjusting cam with the marked positions when tightening.
 - Use a new self-locking nut on reassembly.
 - Use a new spindle nut on reassembly.
 - Before installing a new spindle nut, apply a small amount of engine oil to the seating surface of the nut. After tightening, use a drift to stake the spindle nut shoulder against the driveshaft (4WD) or rear axle shaft (2WD).

- Before installing the brake disc/drum, clean the mating surfaces of the rear hub and the inside of the brake disc/drum.
- Before installing the wheel, clean the mating surfaces of the brake disc/drum and the inside of the wheel.
- Check the rear wheel alignment, and adjust it if necessary (see **WHEEL ALIGNMENT**).

WHEEL BEARING UNIT REPLACEMENT

1. Remove the brake hose mounting bracket (A).

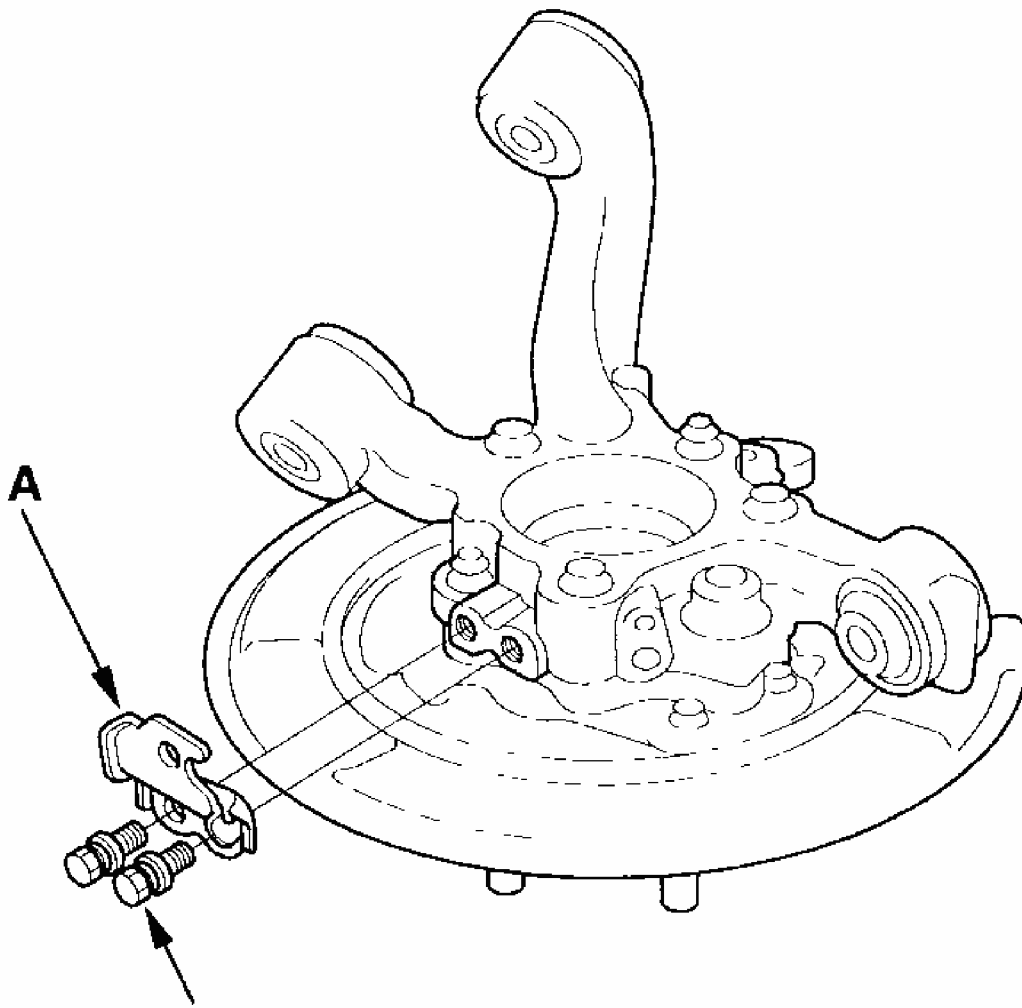

8 x 1.25 mm

G03679117

Fig. 11: Removing Brake Hose Mounting Bracket
Courtesy of AMERICAN HONDA MOTOR CO., INC.

2. Separate the bearing unit (A) from the knuckle (B).

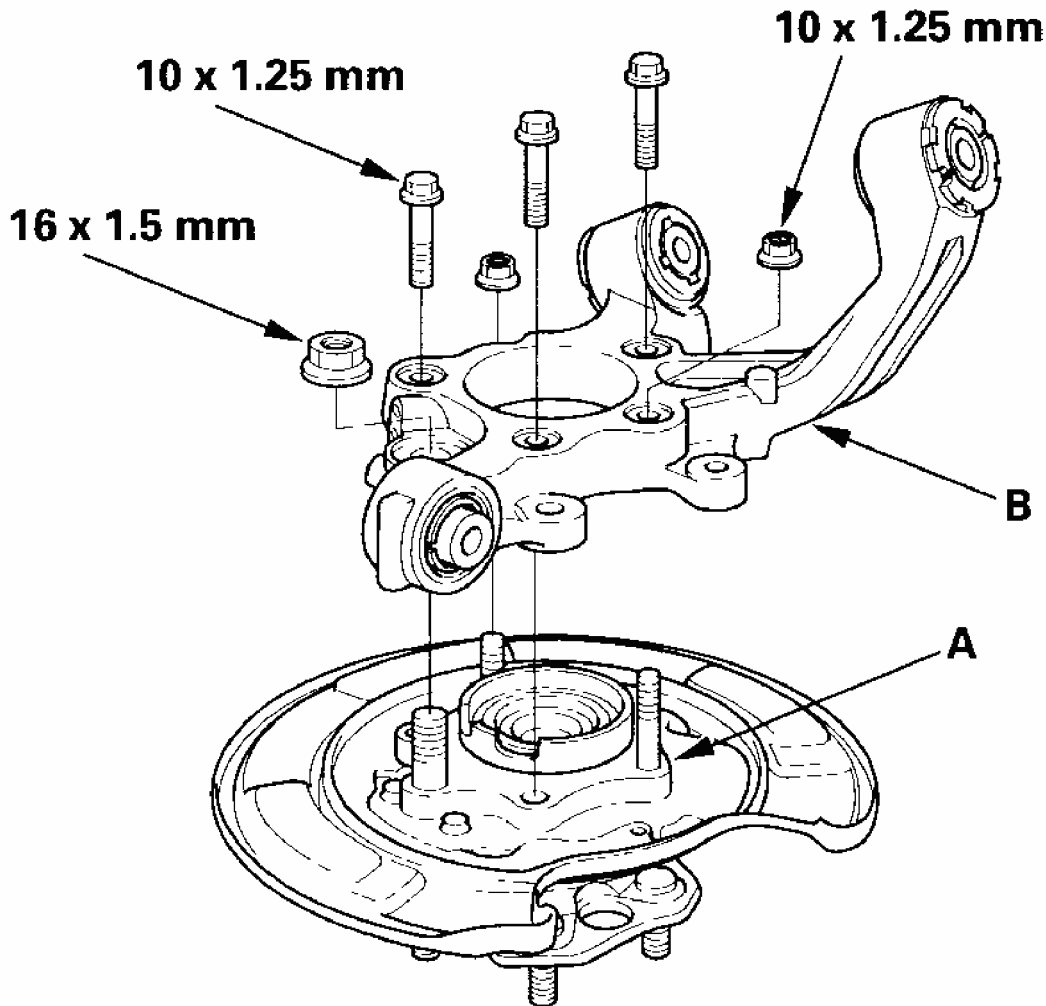

G03679118

Fig. 12: Separating Bearing Unit From Knuckle
Courtesy of AMERICAN HONDA MOTOR CO., INC.

3. Separate the hub (A) and backing plate (B) from bearing unit (C) using the special tool and a hydraulic press. Hold the bearing unit with a press attachment (D) or equivalent tool. Be careful not to deform the backing plate. Hold onto the hub to keep it from falling when pressed clear.

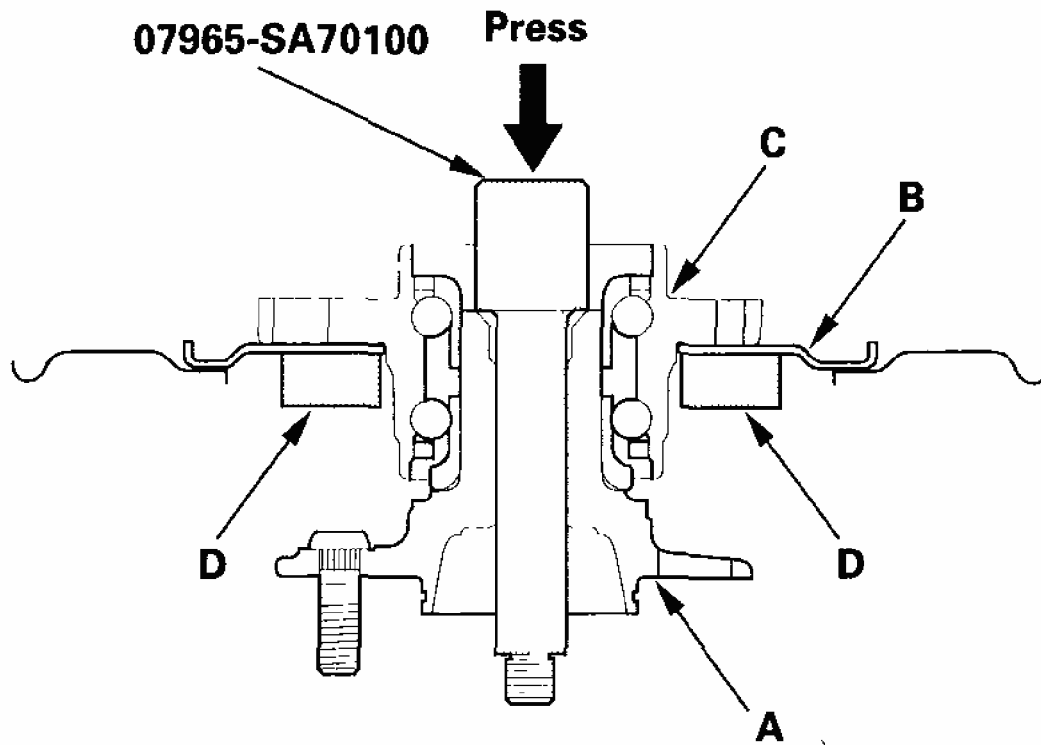

G03679119

Fig. 13: Separating Hub And Backing Plate From Bearing Unit Using Special Tool And A Hydraulic Press

Courtesy of AMERICAN HONDA MOTOR CO., INC.

4. Press the wheel bearing inner race (A) out of the hub (B) using the special tool, a commercially available bearing separator (C), and a press.

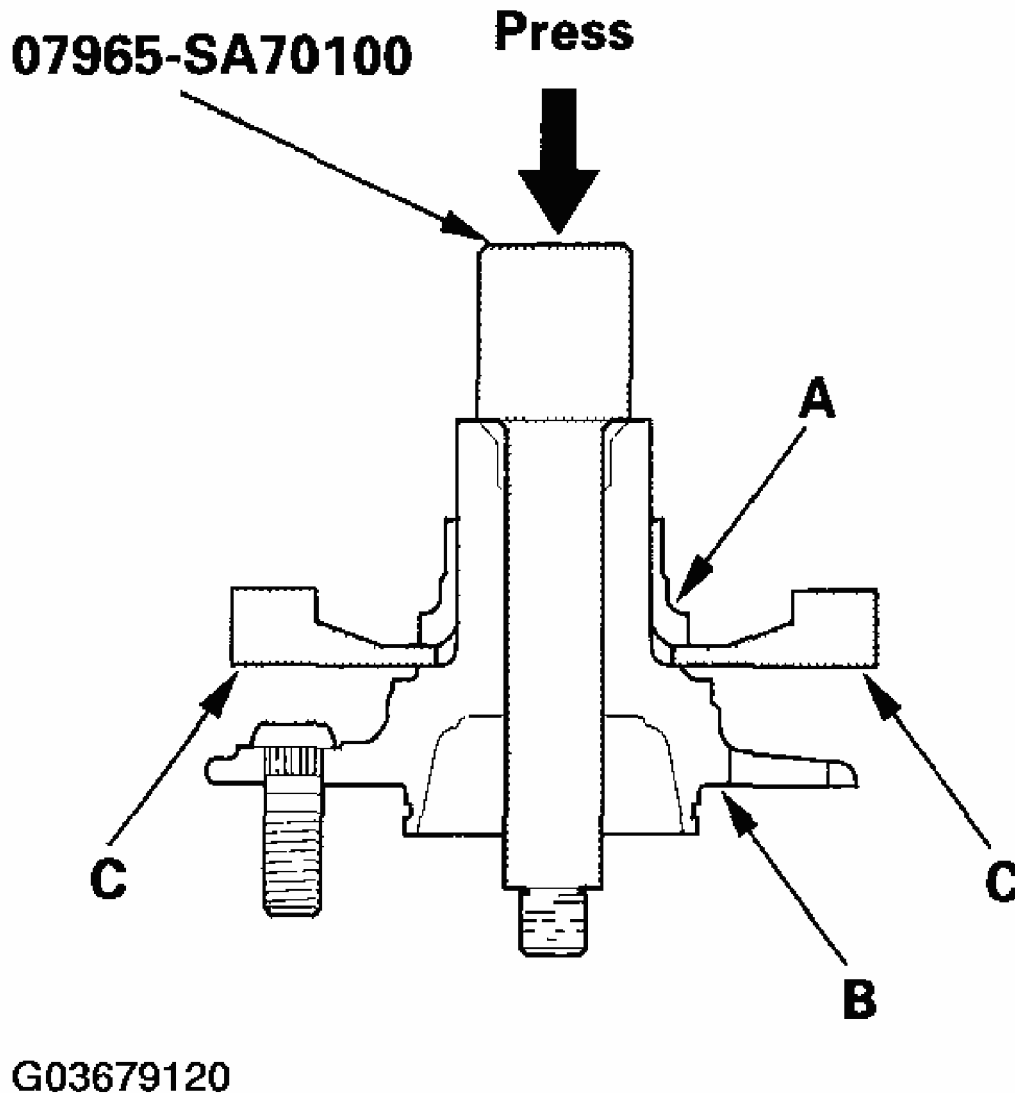

Fig. 14: Pressing Wheel Bearing Inner Race Out Of Hub
Courtesy of AMERICAN HONDA MOTOR CO., INC.

5. Wash the knuckle and hub thoroughly in a high flash point solvent before reassembly.
6. Install the hub (A) and backing plate (B) on the new bearing unit (C) using the special tools and a hydraulic press. Be careful not to deform the backing plate.

NOTE (with ABS):

- Remove any oil, grease, dust, or other foreign material from the encoder surface (D).

- Keep magnetic tools away from the encoder surface.
- Be careful not to damage the encoder surface.

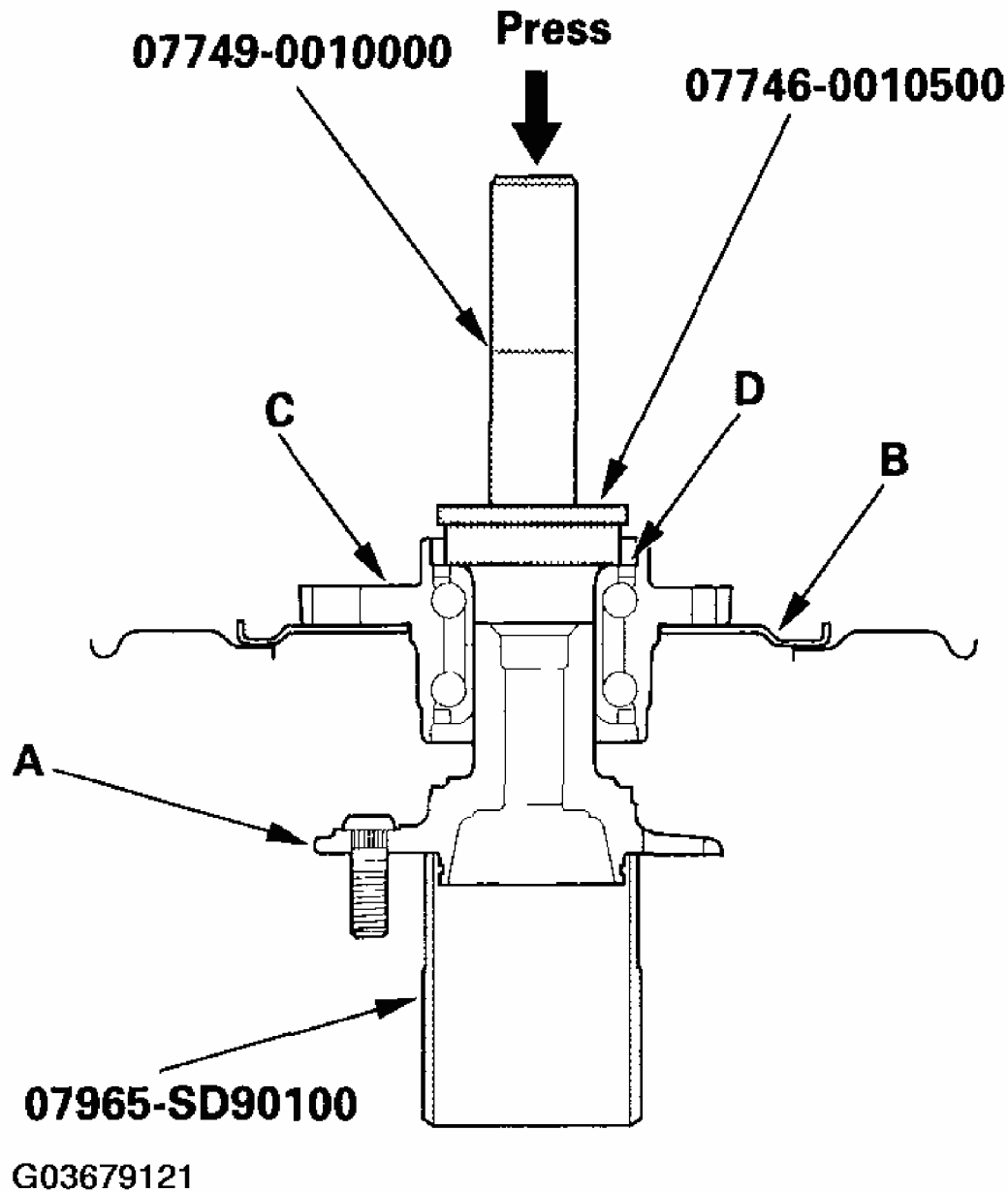
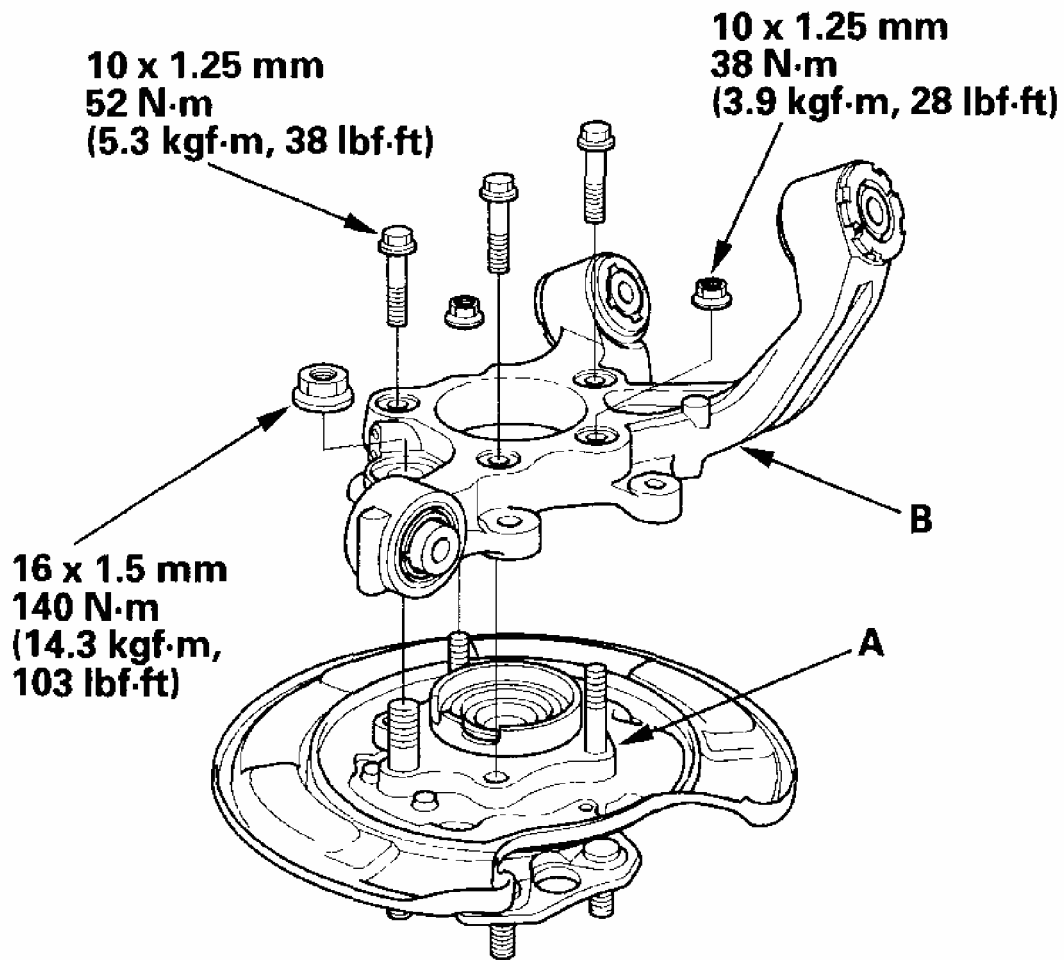

Fig. 15: Installing Hub And Backing Plate On New Bearing Unit Using Special Tools

Courtesy of AMERICAN HONDA MOTOR CO., INC.

7. Install the bearing unit (A) and knuckle (B).



G03679122

Fig. 16: Installing Bearing Unit And Knuckle
Courtesy of AMERICAN HONDA MOTOR CO., INC.

8. Install the brake hose mounting bracket (A).

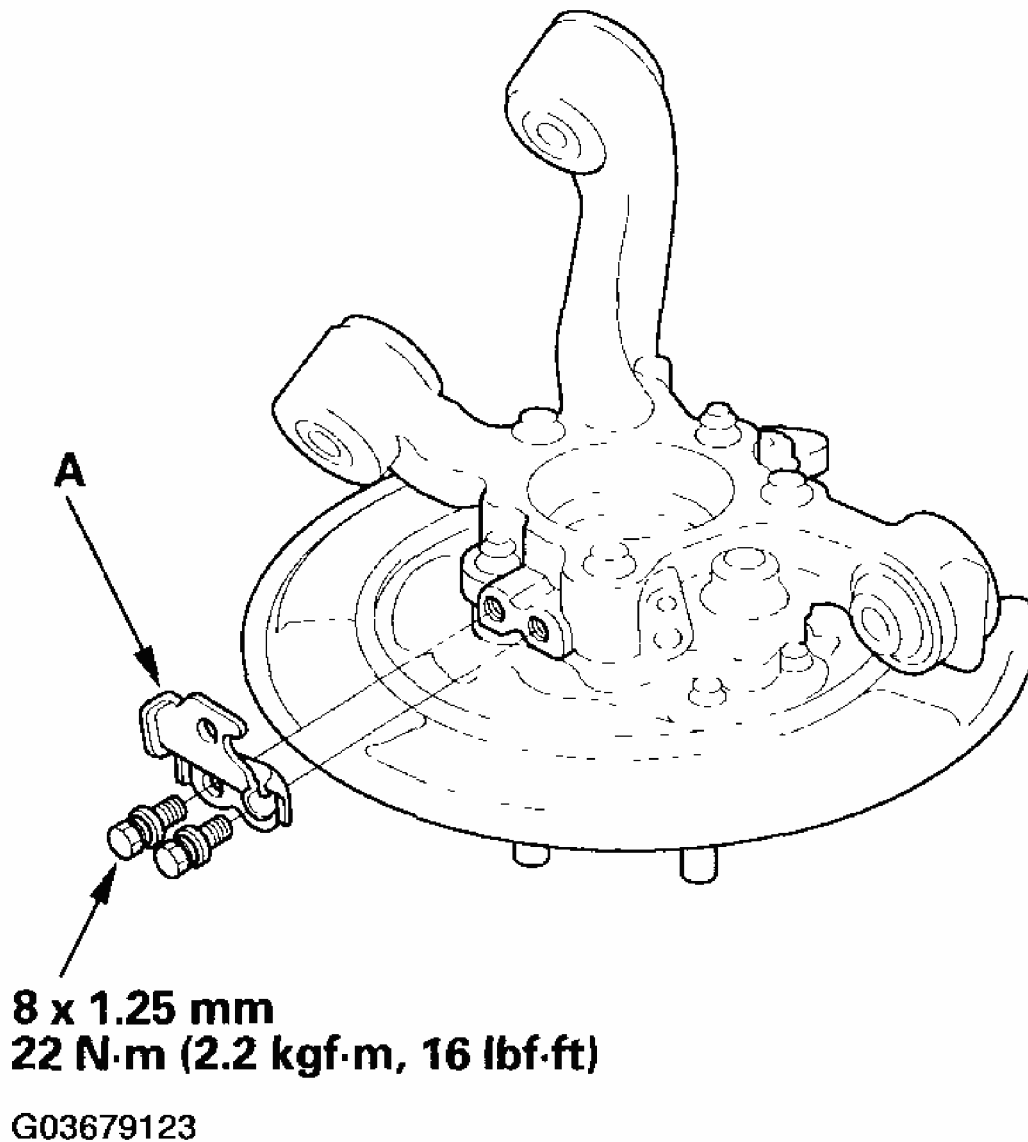
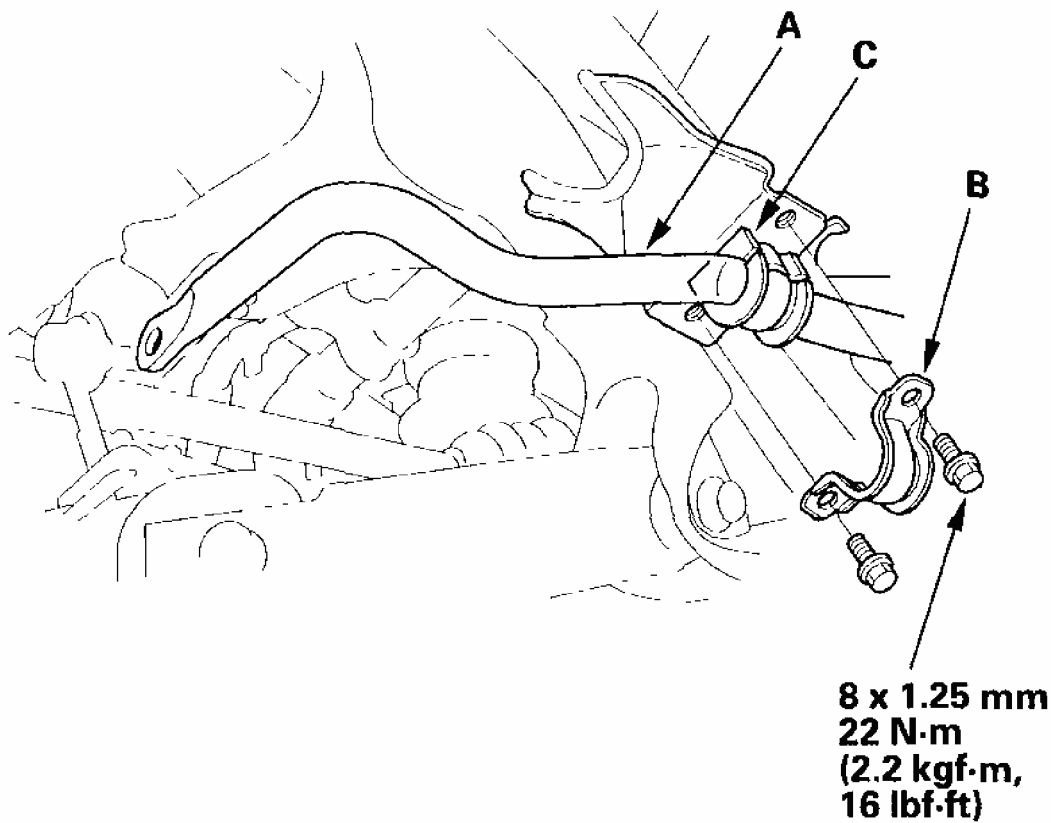

Fig. 17: Installing Brake Hose Mounting Bracket
Courtesy of AMERICAN HONDA MOTOR CO., INC.

STABILIZER BAR REPLACEMENT

1. Raise the rear of the vehicle, and support it with safety stands in the proper locations (see **SAFETY STANDS**).
2. Remove the rear wheels.
3. Disconnect the stabilizer links from the stabilizer bar (A) on the right and left sides (see **STABILIZER LINK REMOVAL/INSTALLATION**).



G03679124

Fig. 18: Removing Stabilizer Link

Courtesy of AMERICAN HONDA MOTOR CO., INC.

4. Remove the flange bolts and bushing holders (B), then remove the bushings (C) and the stabilizer bar.
5. Install the stabilizer bar in the reverse order of removal, and note these items:
 - Use new self-locking nuts on reassembly.
 - Make sure the right and left ends of the stabilizer bar are installed on their respective sides of the vehicle.
 - Align the ends of the paint marks (A) on the stabilizer bar with the bushings (B).
 - Refer to stabilizer link removal/installation to connect the stabilizer bar to the links (see **STABILIZER LINK REMOVAL/INSTALLATION**).

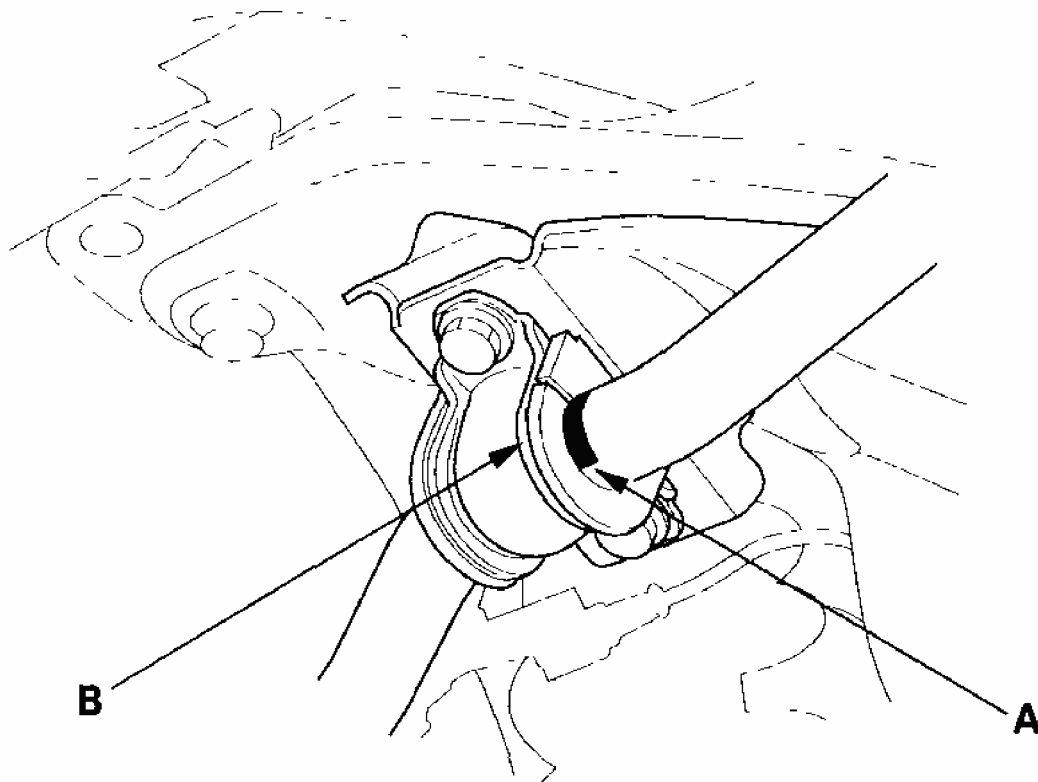

G03679125

Fig. 19: Removing Stabilizer Link

Courtesy of AMERICAN HONDA MOTOR CO., INC.

STABILIZER LINK REMOVAL/INSTALLATION

1. Raise the rear of the vehicle, and support it with safety stands in the proper locations (see **SAFETY STANDS**).
2. Remove the rear wheel.
3. Remove the self-locking nut (A) and flange nut (B) while holding the respective joint pin (C) with a hex wrench (D), and remove the stabilizer link (E).

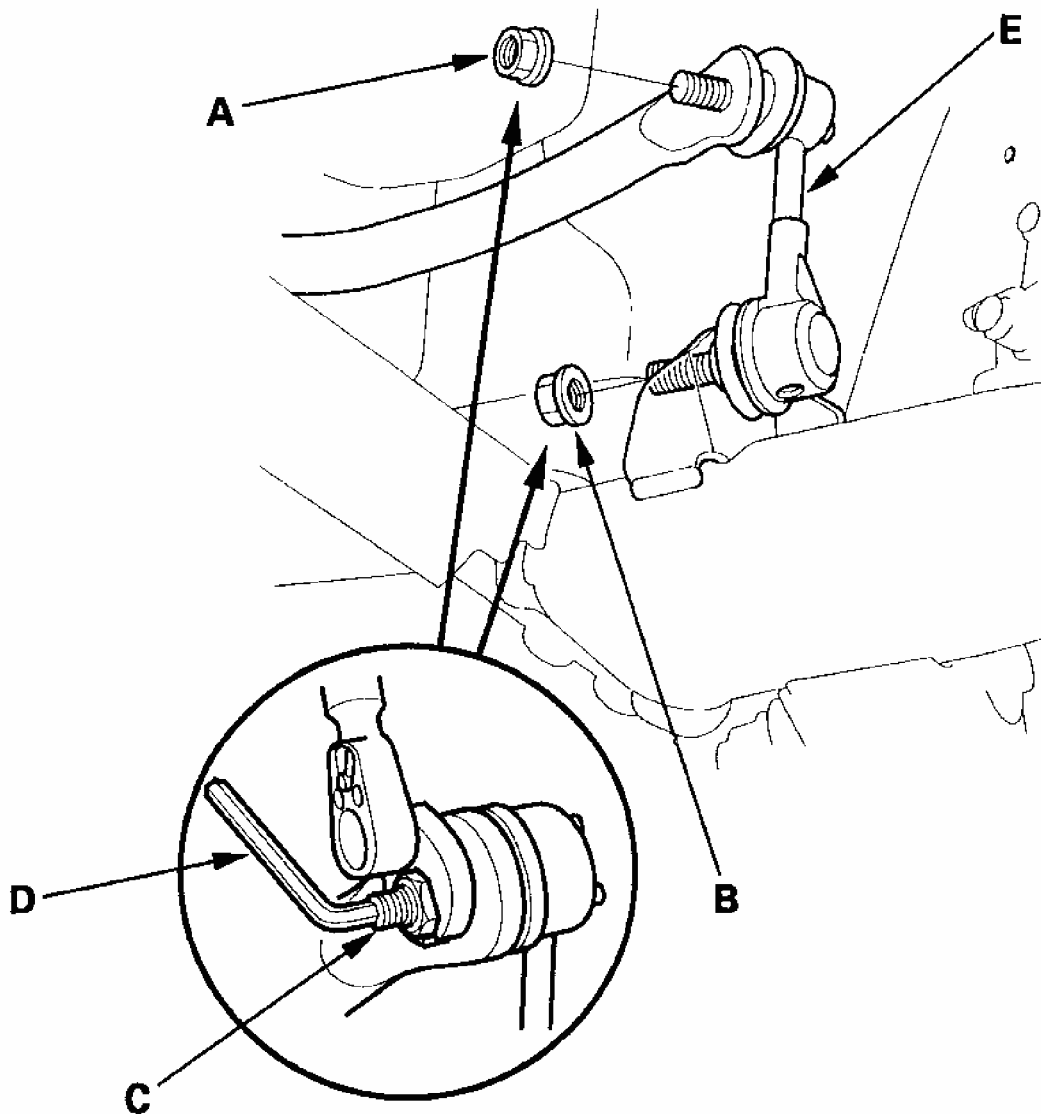

G03679126

Fig. 20: Removing Self-Locking Nut And Flange Nut While Holding Respective Joint Pin

Courtesy of AMERICAN HONDA MOTOR CO., INC.

4. Install the stabilizer link (A) on the stabilizer bar (B) and trailing arm (C) with the joint pins (D) set at the center of their range of movement.

NOTE: The left stabilizer has a yellow paint mark (E), while the right stabilizer link has a white paint mark.

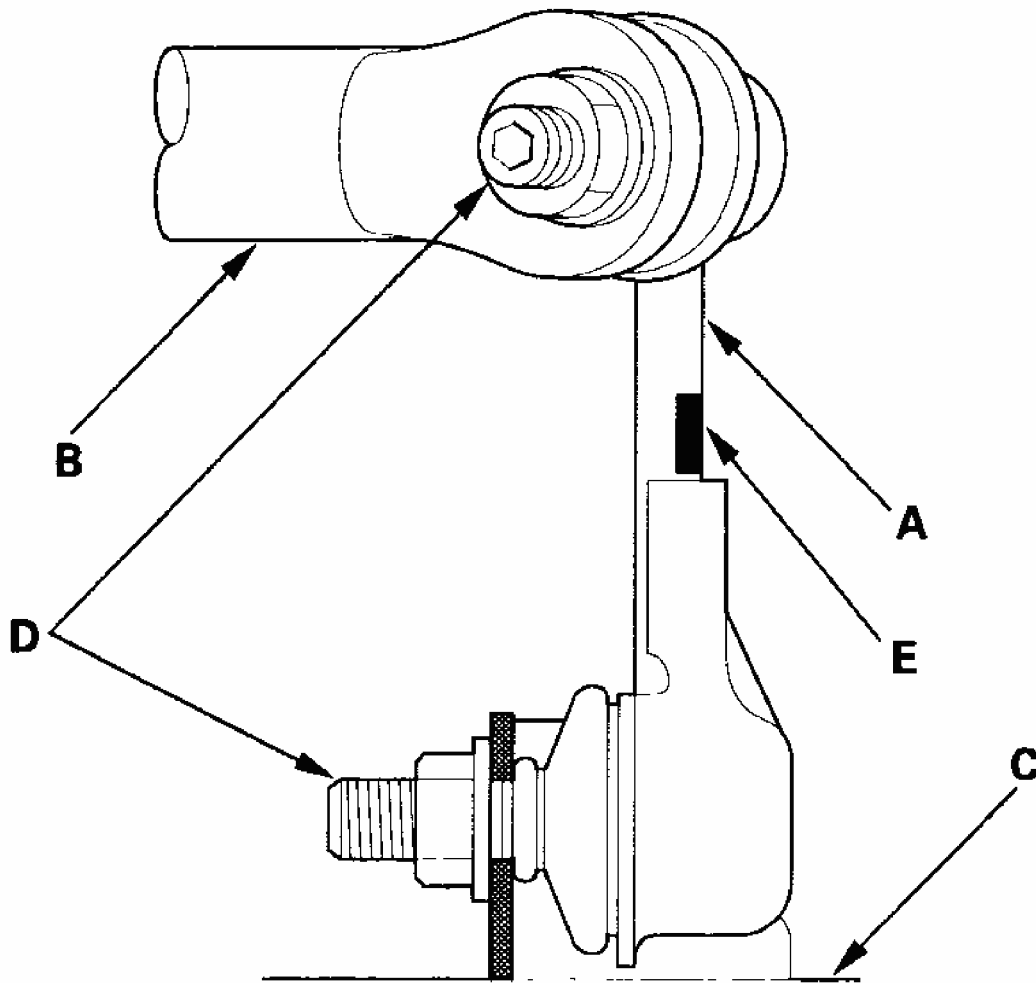

G03679127

Fig. 21: Installing Stabilizer Link On Stabilizer Bar And Trailing Arm With Joint Pins

Courtesy of AMERICAN HONDA MOTOR CO., INC.

5. Install a new self-locking nut and flange nut, and lightly tighten them.

NOTE: Use a new self-locking nut on reassembly.

6. Place a jack under the trailing arm at the knuckle-side end, and raise the suspension to load it with the vehicle's weight.
7. Tighten the self-locking nut (A) and flange nut (B) to the specified torque values while holding the respective joint pins (C) with a hex wrench (D).

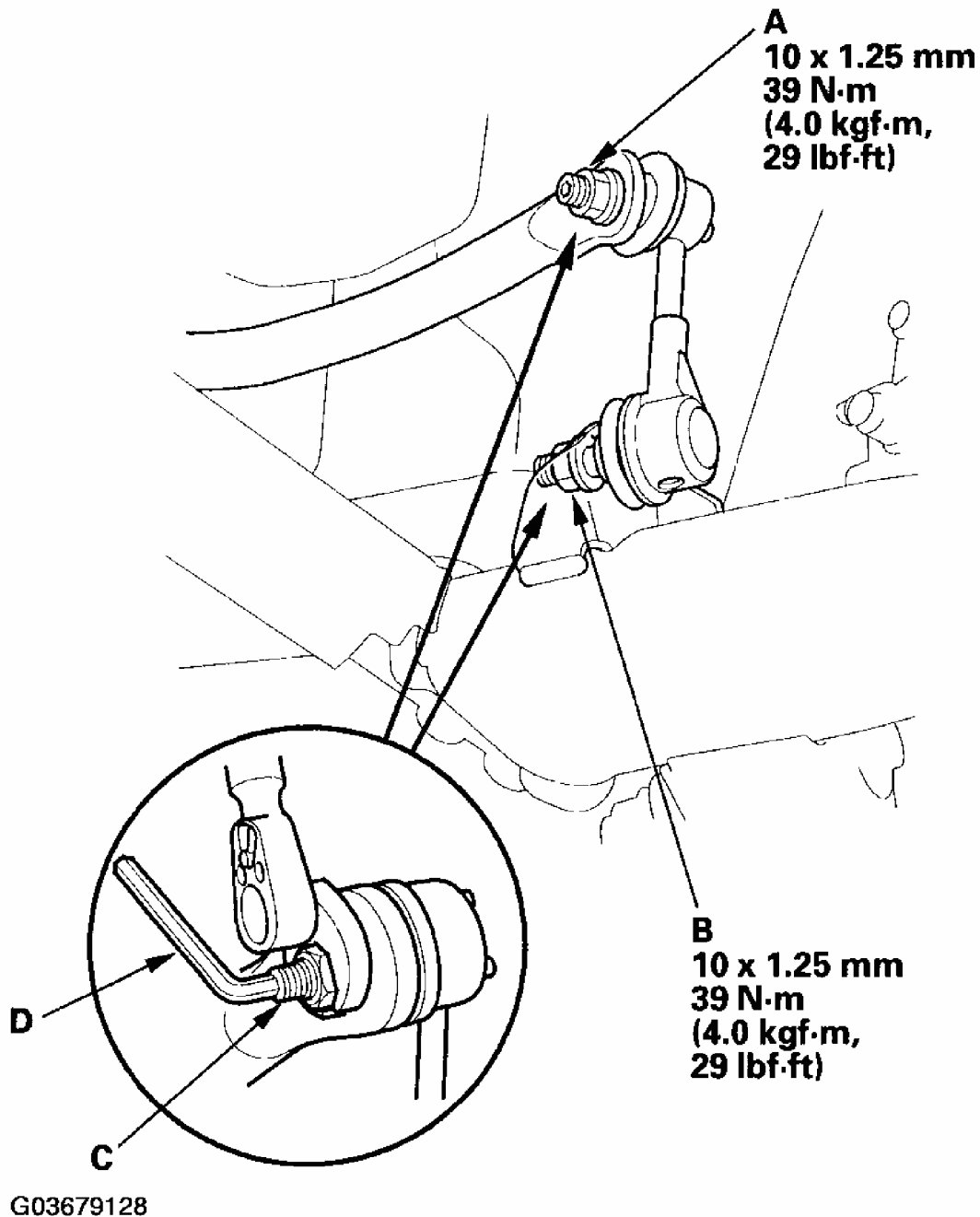
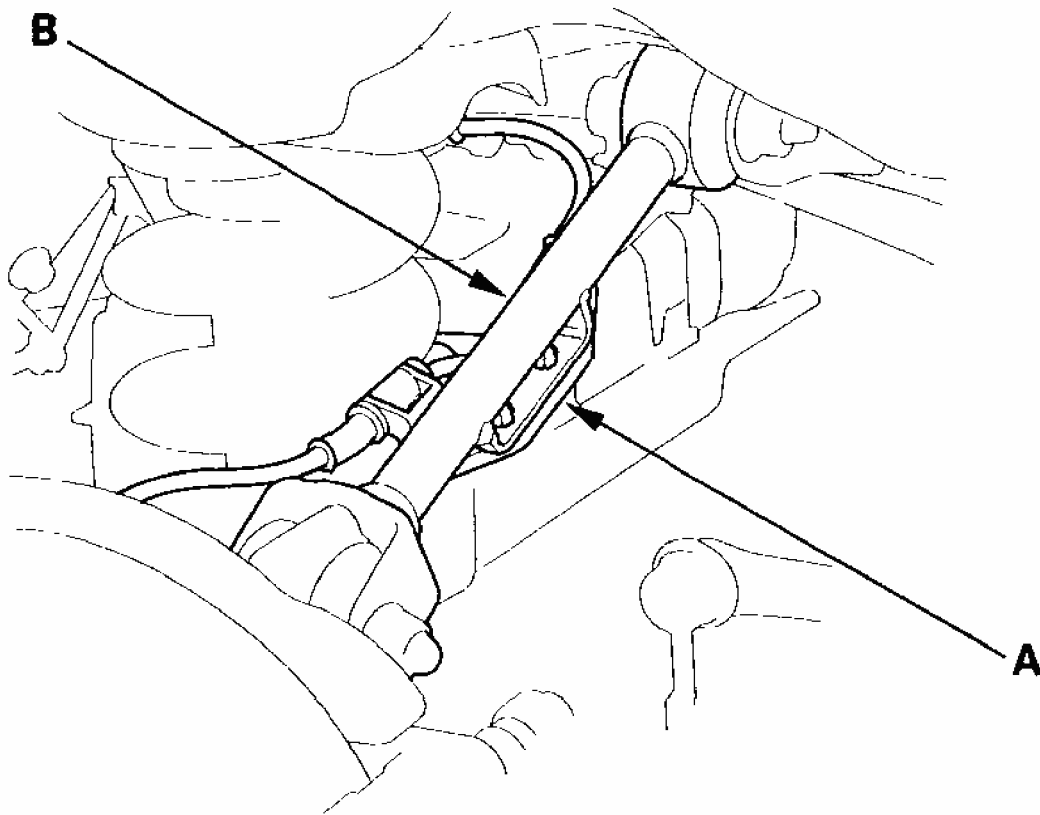

Fig. 22: Tightening Self-Locking Nut And Flange Nut
Courtesy of AMERICAN HONDA MOTOR CO., INC.

8. Reinstall the rear wheel and test-drive the vehicle.
9. After 5 minutes of driving, torque the self-locking nut torque value again.

UPPER ARM REPLACEMENT

1. Raise the rear of the vehicle, and support it with safety stands in the proper locations (see **SAFETY STANDS**).
2. Remove the rear wheel.
3. Place a floor jack under the trailing arm, and support the suspension.
4. Remove the wheel sensor harness bracket (A) from the upper arm (B).



G03679129

Fig. 23: Removing Wheel Sensor Harness Bracket (With ABS) From Upper Arm
Courtesy of AMERICAN HONDA MOTOR CO., INC.

5. Remove the flange bolts (A), and remove the upper arm (B).

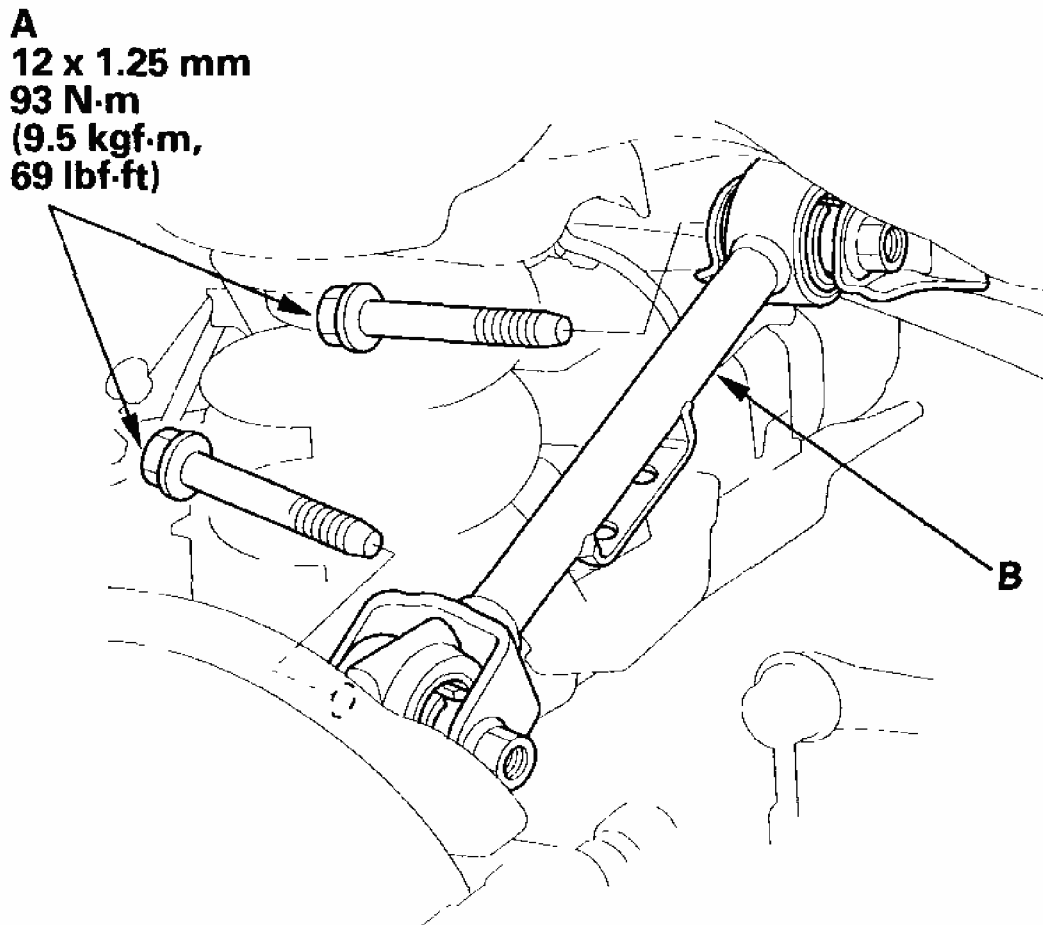

G03679130

Fig. 24: Removing Flange Bolts

Courtesy of AMERICAN HONDA MOTOR CO., INC.

6. Install the upper arm in the reverse order of removal, and note these items:
 - First install all the suspension components and lightly tighten the bolts and nuts, then place a jack under the trailing arm. Raise the suspension with a floor jack to load it with the vehicle's weight before fully tightening the bolts and nuts to the specified torque values.
 - Tighten all the mounting hardware to the specified torque values.
 - Before installing the wheel, clean the mating surface of the brake disc/drum and the inside of the wheel.
 - Check the wheel alignment, and adjust it if necessary (see **WHEEL ALIGNMENT**).

TRAILING ARM REPLACEMENT

1. Raise the rear of the vehicle, and support it with safety stands in the proper locations (see **SAFETY STANDS**).
2. Remove the rear wheel.
3. Remove the knuckle (see **KNUCKLE REPLACEMENT**).
4. Place the floor jack under the trailing arm (A) to support it.

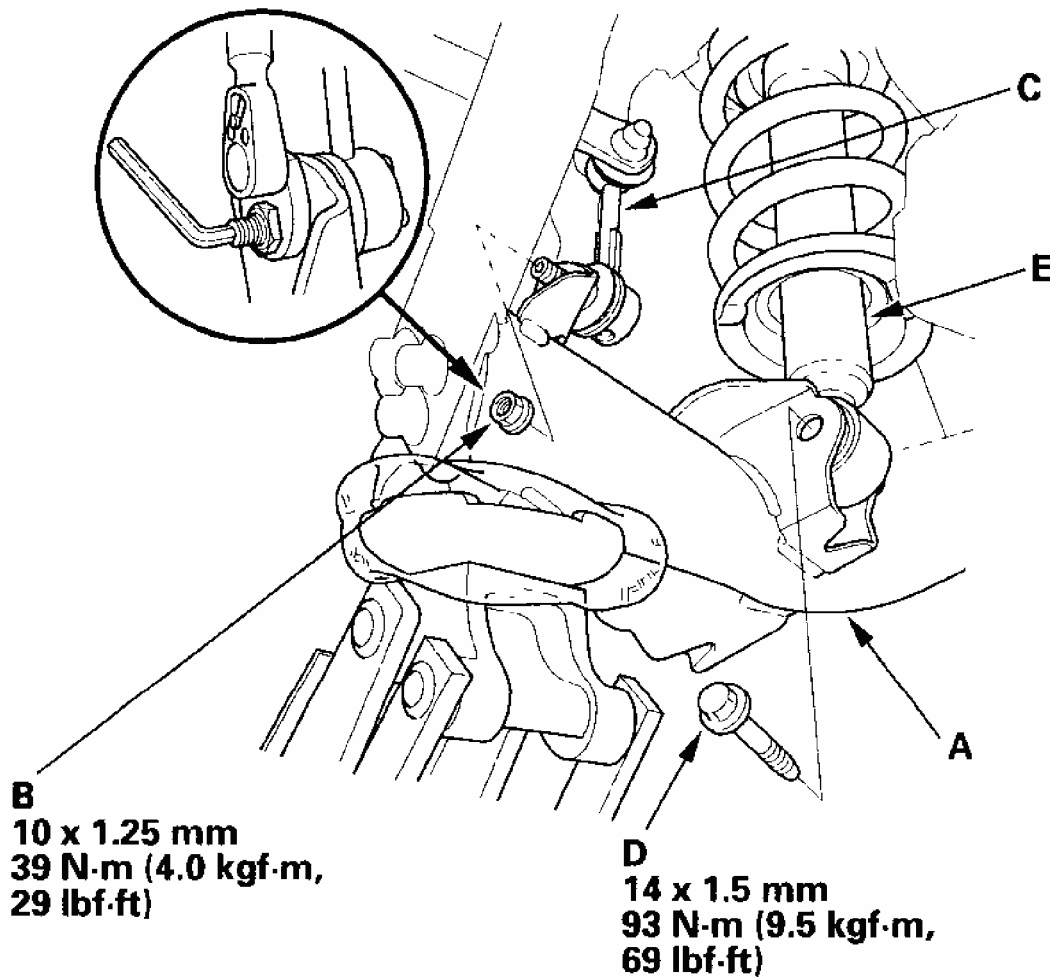

G03679131

Fig. 25: Placing Floor Jack Under Trailing Arm And Torque Specifications
Courtesy of AMERICAN HONDA MOTOR CO., INC.

5. Remove the flange nut (B), and disconnect the stabilizer link (C) from the trailing arm.
6. Remove the flange bolt (D), and disconnect the damper (E) from the trailing arm.
7. Remove the trailing arm front mounting bolts (A).

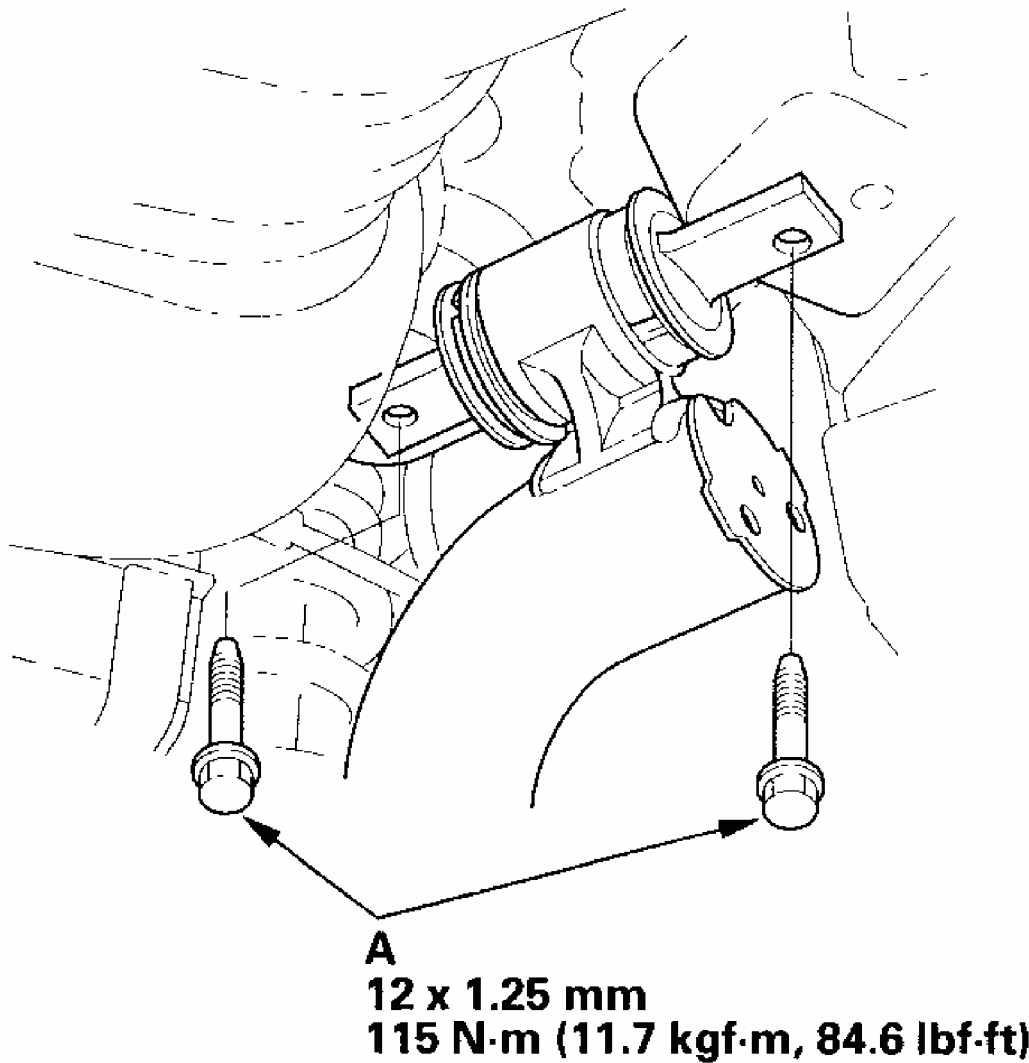

G03679132

Fig. 26: Removing Trailing Arm Front Mounting Bolts And Torque Specifications
Courtesy of AMERICAN HONDA MOTOR CO., INC.

8. Remove the trailing arm rear mounting bolt (A).

NOTE: Do not loosen the special bolts (B) on the trailing arm.

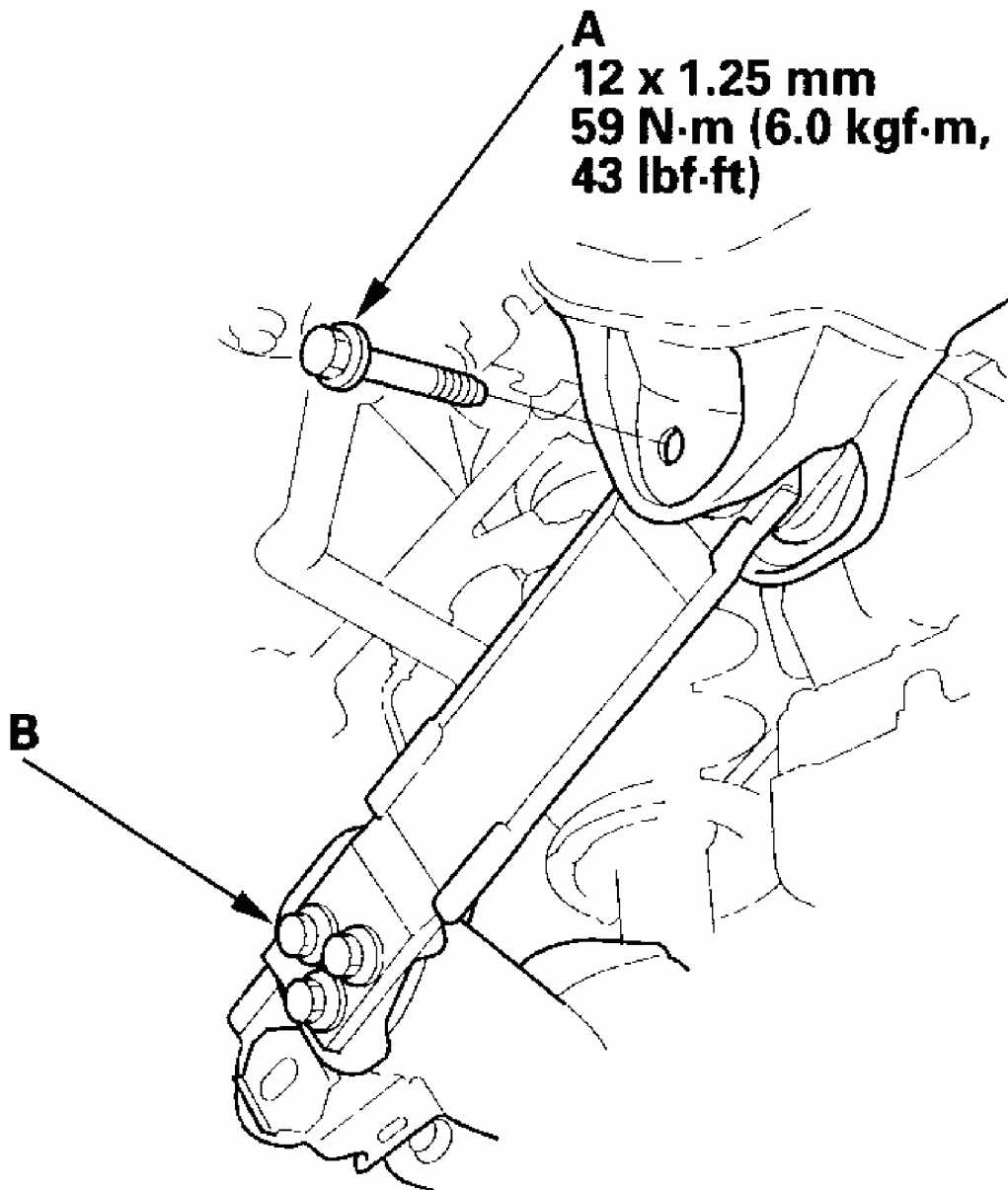

G03679133

Fig. 27: Removing Trailing Arm Rear Mounting Bolt And Torque Specifications
Courtesy of AMERICAN HONDA MOTOR CO., INC.

9. Lower the jack, and remove the trailing arm.
10. Install the trailing arm in the reverse order of removal, and note these items:
 - First install all the suspension components and lightly tighten the bolts and nuts, then place a jack under the trailing arm. Raise the suspension to load it with the

2004 Honda Element DX

2003-06 SUSPENSION Rear Suspension - Element

vehicle's weight before fully tightening the bolts and nuts to the specified torque values.

- Tighten all the mounting hardware to the specified torque values.
- Before installing the wheel, clean the mating surface of the brake disc/drum and the inside of the wheel.
- Check the wheel alignment, and adjust it if necessary (see **WHEEL ALIGNMENT**).

DAMPER/SPRING REPLACEMENT

EXPLODED VIEW

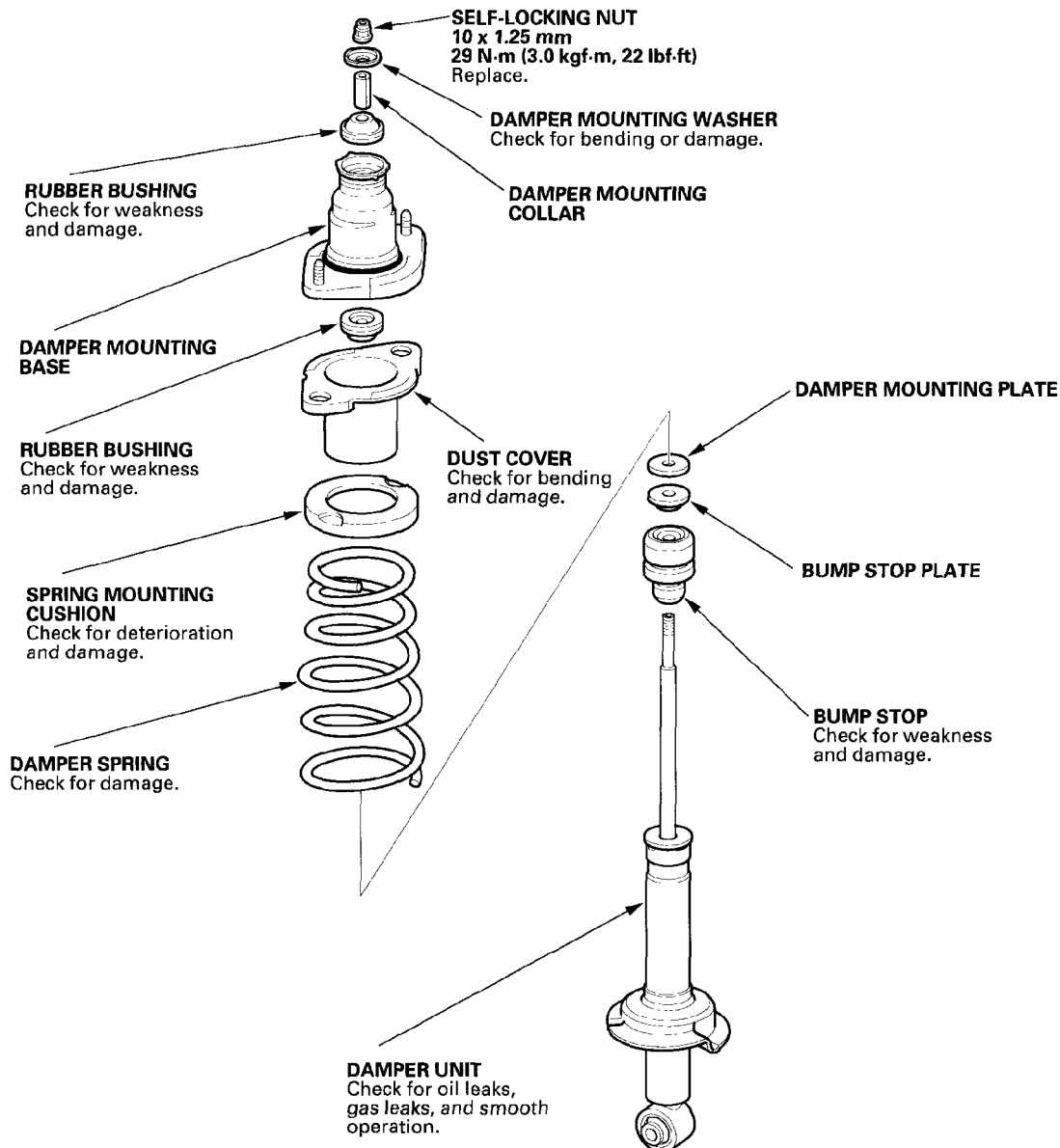
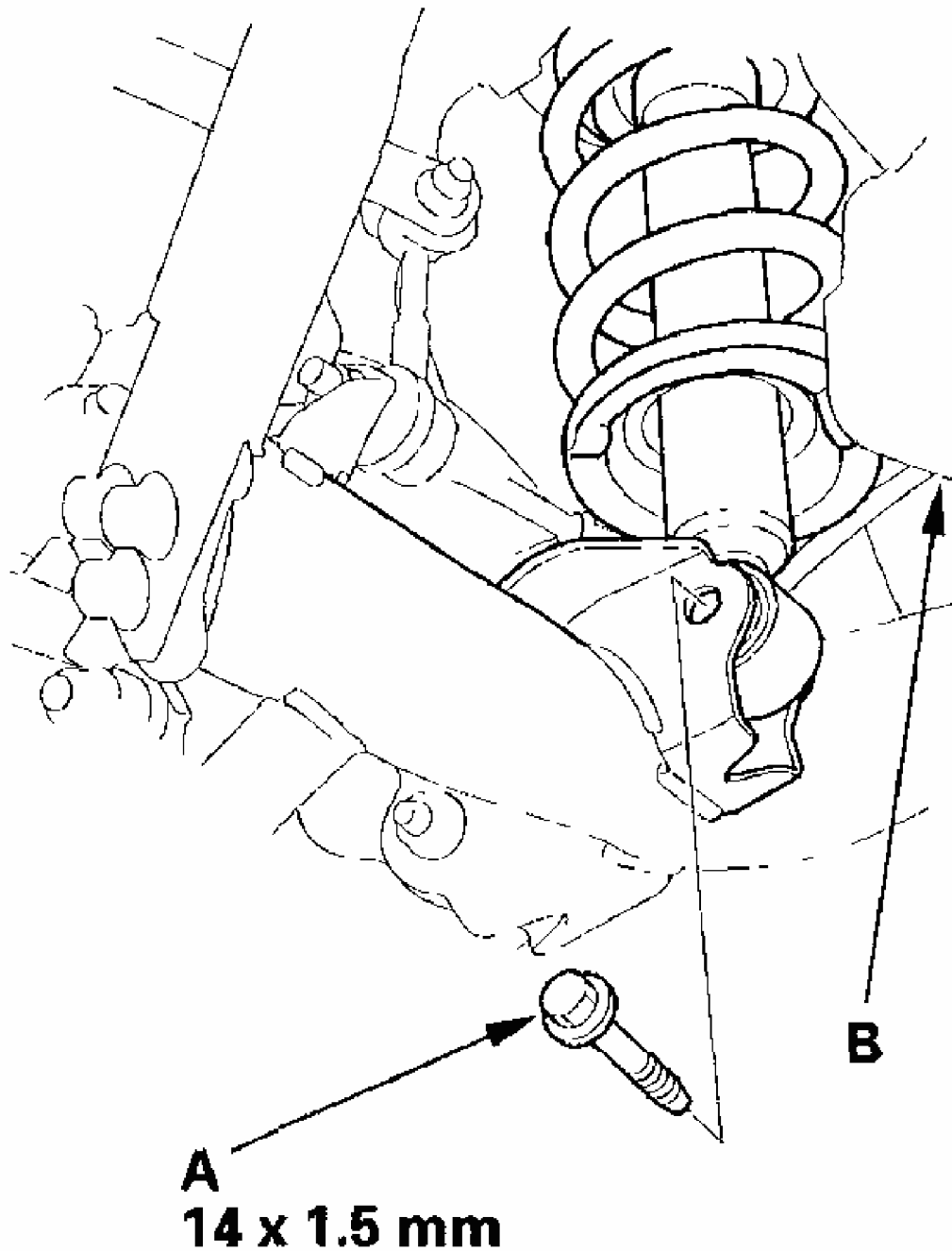

Fig. 28: Exploded View Of Damper/Spring Components And Torque Specifications
Courtesy of AMERICAN HONDA MOTOR CO., INC.

NOTE: When compressing the damper spring, use a commercially available strut spring compressor (Branick MST-580A or Model 7200 or equivalent). According to the manufacturer's instructions.

REMOVAL

1. Raise the rear of the vehicle, and support it with safety stands in the proper locations (see **SAFETY STANDS**).
2. Remove the rear wheel.
3. Remove the flange bolt (A) from the bottom of the damper.



G03679135

Fig. 29: Removing Flange Bolt From Bottom Of Damper
Courtesy of AMERICAN HONDA MOTOR CO., INC.

4. Remove the canister mounting bolts, and loosen the EVAP canister (B) mounting (only

left side) (see **EVAP CANISTER REPLACEMENT**).

5. Remove the flange nuts (A) from the top of the damper in the cargo area.

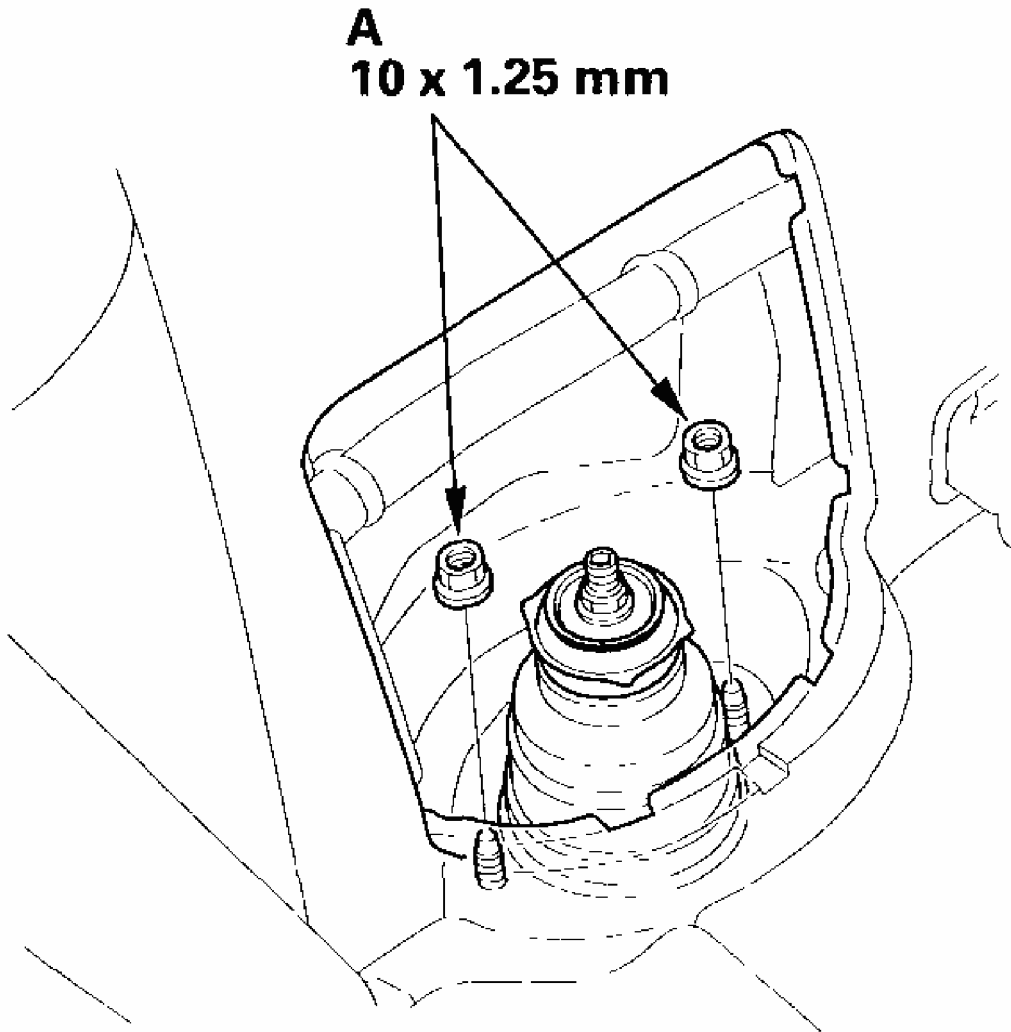

G03679136

Fig. 30: Removing Flange Nuts From Top Of Damper In Cargo Area
Courtesy of AMERICAN HONDA MOTOR CO., INC.

6. Remove the damper assembly (A) from the body.

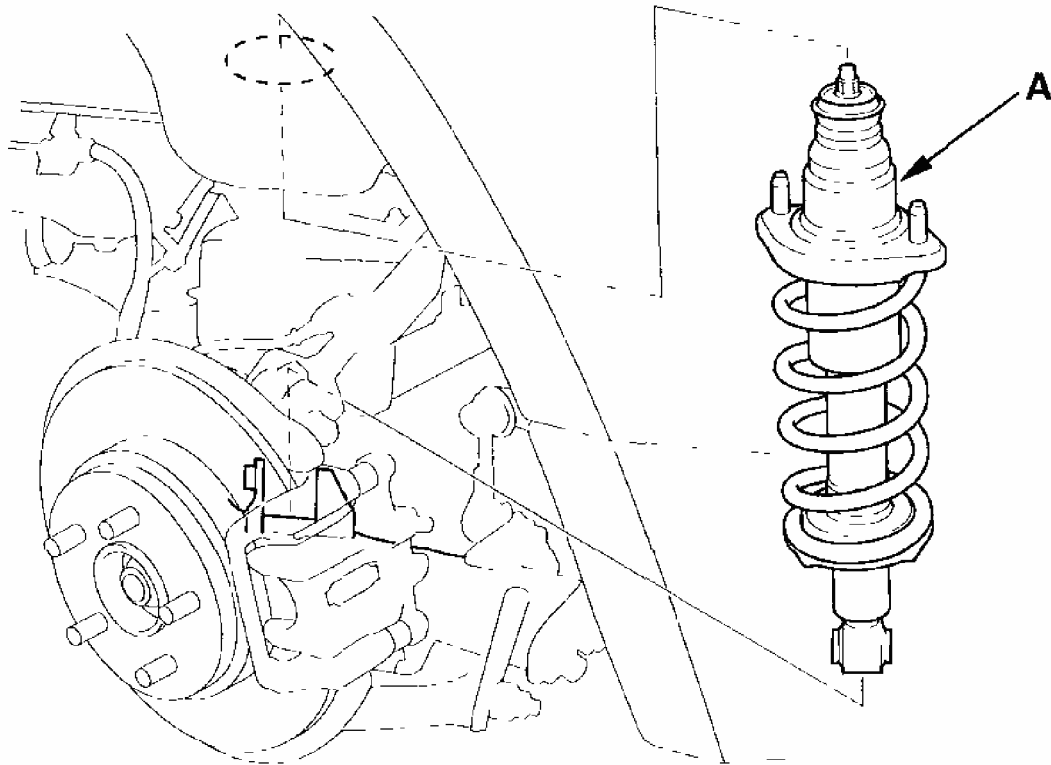

G03679137

Fig. 31: Removing Damper Assembly From Body
Courtesy of AMERICAN HONDA MOTOR CO., INC.

DISASSEMBLY/INSPECTION

1. Compress the damper spring, then remove the self-locking nut (A) while holding the damper shaft (B) with a hex wrench (C). Do not compress the spring more than necessary to remove the nut.

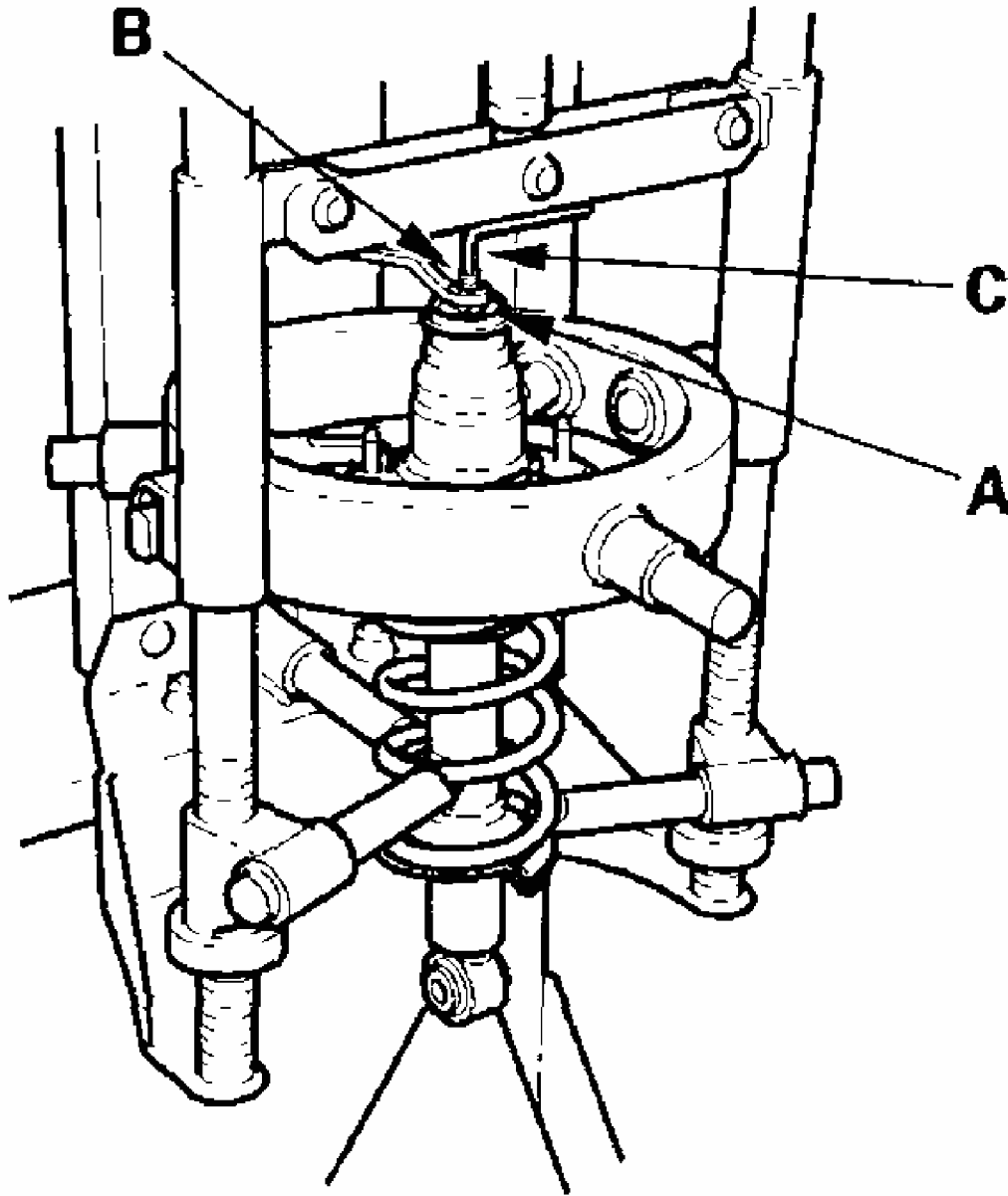

G03679138

Fig. 32: Compressing Damper Spring

Courtesy of AMERICAN HONDA MOTOR CO., INC.

2. Release the pressure from the strut spring compressor, then disassemble the damper as shown in the Exploded View.
3. Reassemble all the parts, except for the spring.
4. Compress the damper assembly by hand, and check for smooth operation through a full

stroke, both compression and extension. The damper should extend smoothly and constantly when compression is released. If it does not, the gas is leaking and the damper should be replaced.

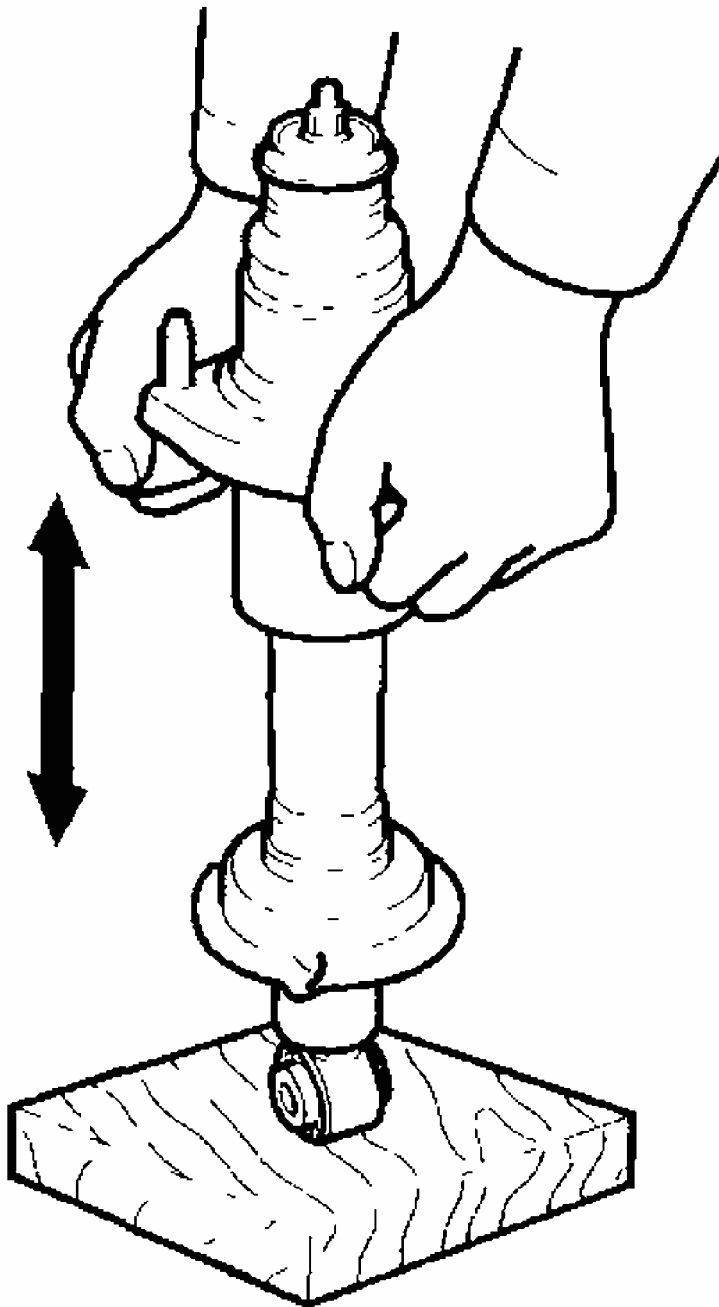

G03679139

Fig. 33: Compressing Damper Assembly
Courtesy of AMERICAN HONDA MOTOR CO., INC.

5. Check for oil leaks, abnormal noises, or binding during these tests.

REASSEMBLY

1. Install all the parts except the damper mounting washer and self-locking nut onto the damper unit by referring to the Exploded View. Align the bottom of the spring (A) and the stepped part of the lower spring seat (B), and align the damper mounting base as shown.

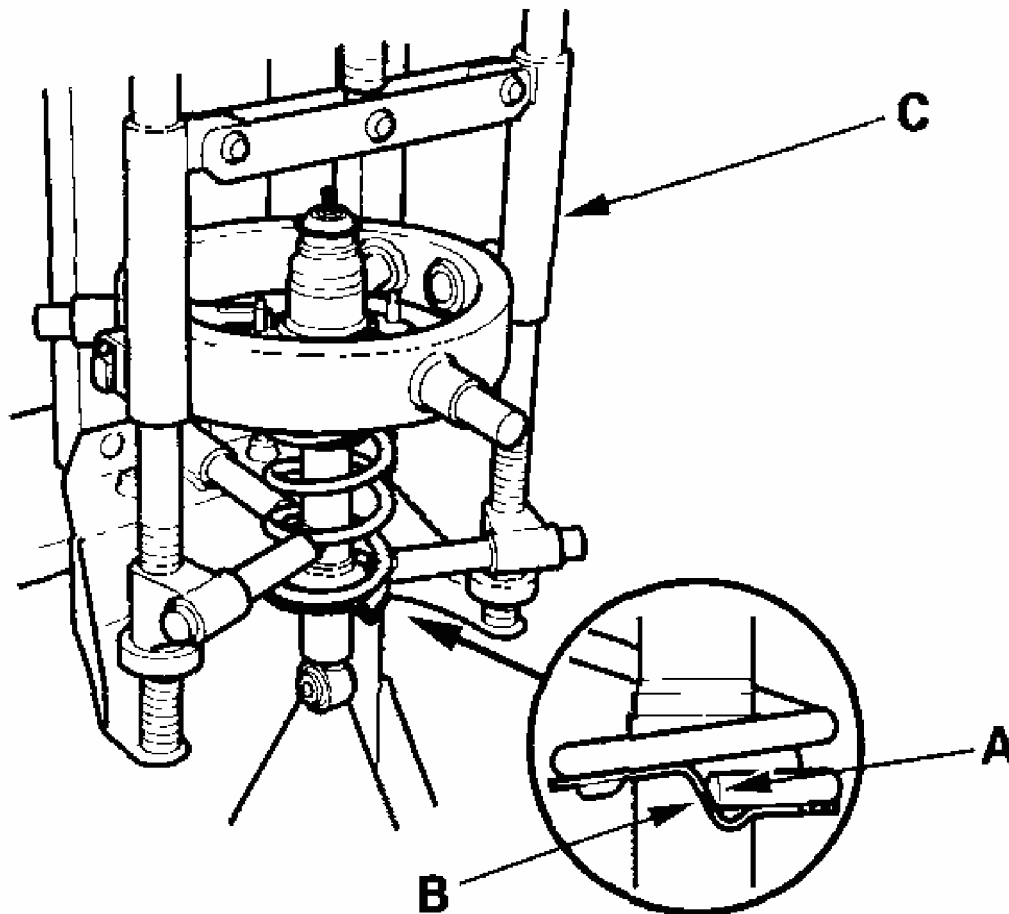

G03679140

Fig. 34: Installing Parts Except Damper Mounting
Courtesy of AMERICAN HONDA MOTOR CO., INC.

Left side

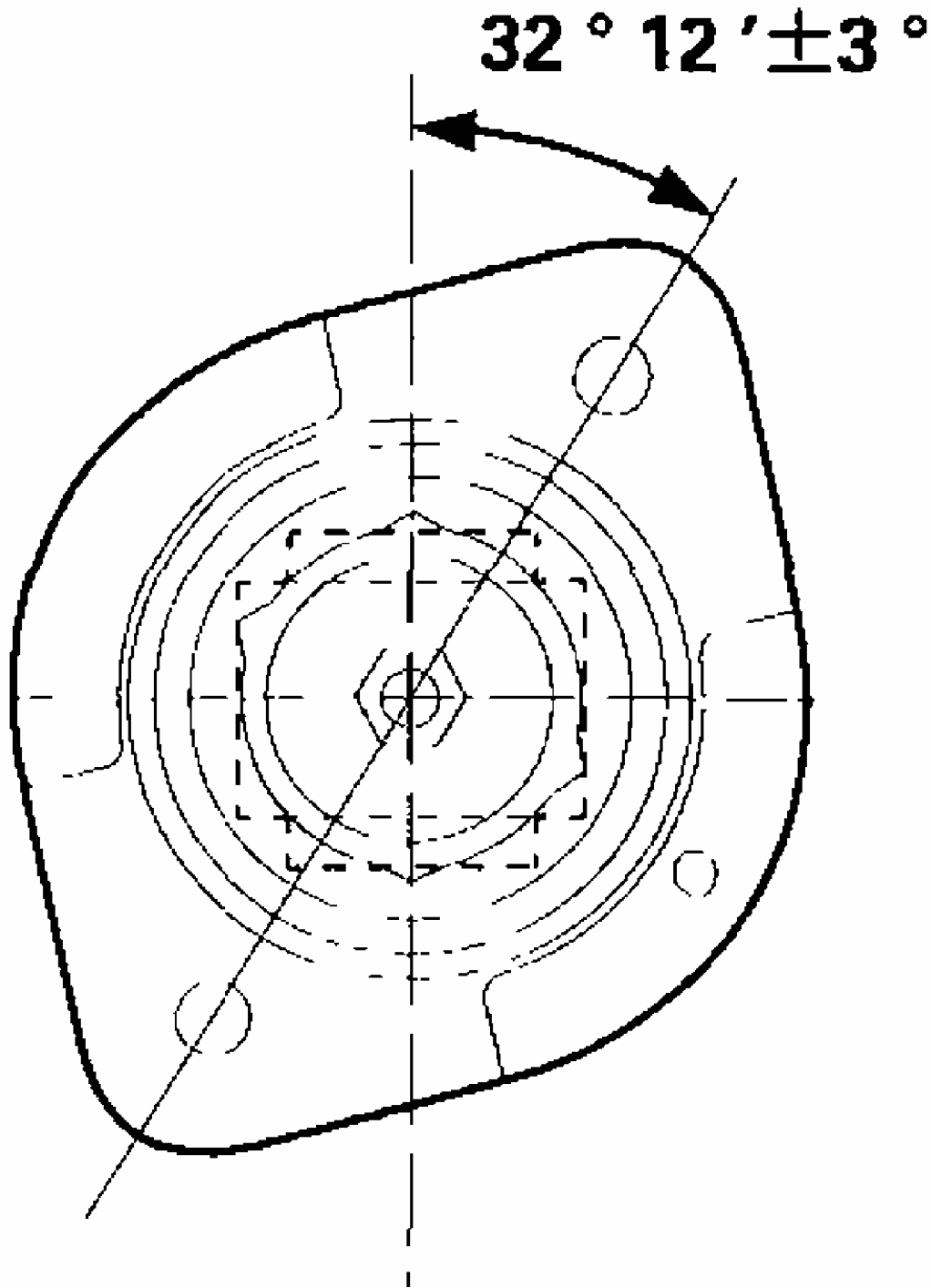

G03679141

Fig. 35: Identifying Left Side Seal
Courtesy of AMERICAN HONDA MOTOR CO., INC.

2004 Honda Element DX

2003-06 SUSPENSION Rear Suspension - Element

Right side

32° 12' ± 3°

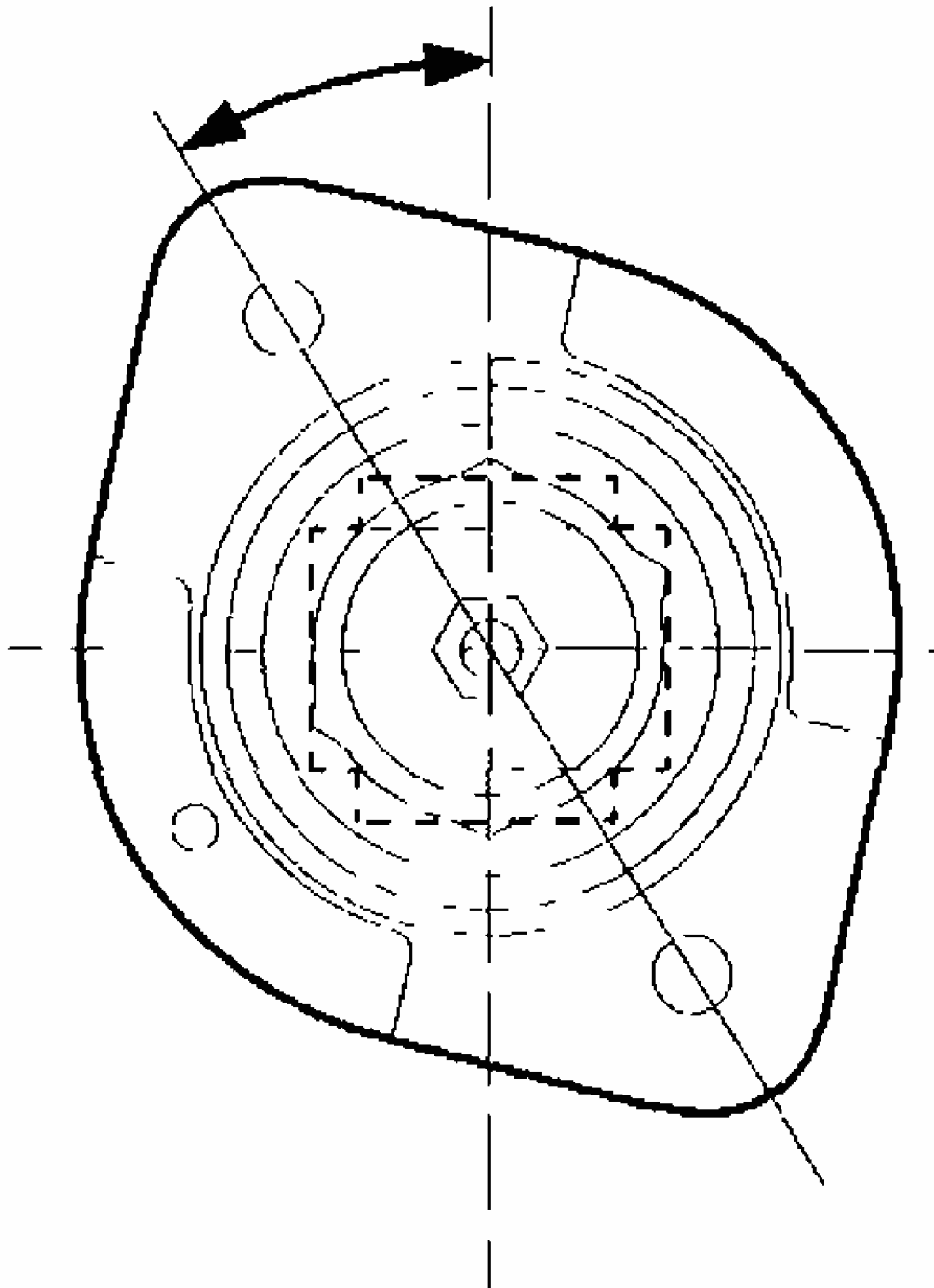

G03679142

Fig. 36: Identifying Right Side Seal

Courtesy of AMERICAN HONDA MOTOR CO., INC.

2. Install the damper assembly on a strut spring compressor (C).
3. Compress the damper spring with the strut spring compressor.
4. Install the washer (A) and a new 10 mm self-locking nut (B).

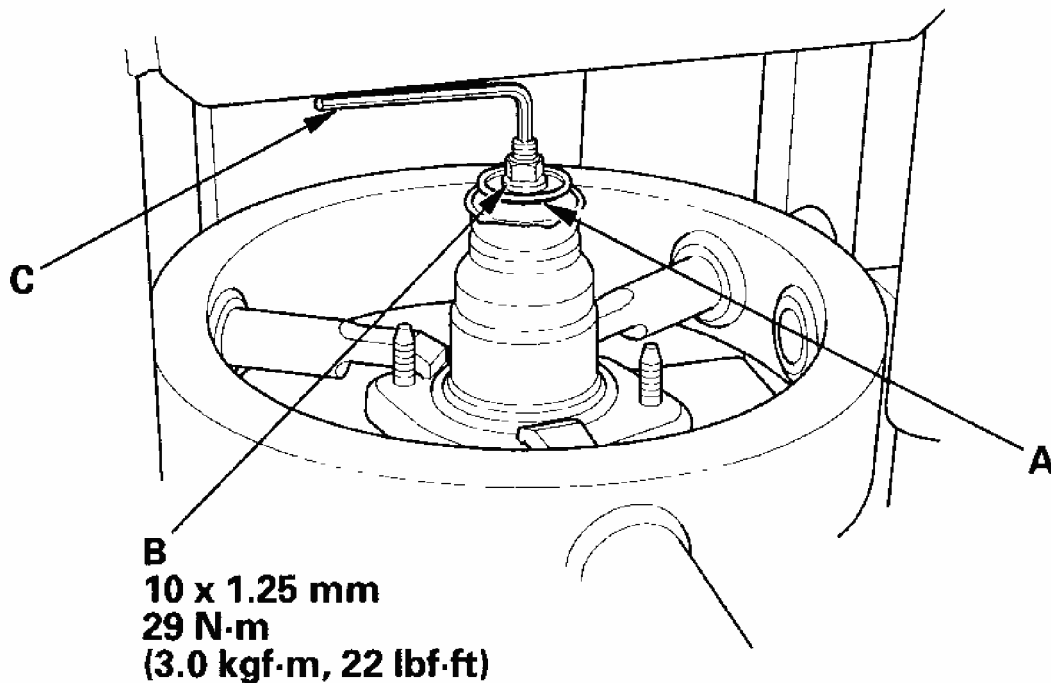

G03679143

Fig. 37: Installing Washer And Self-Locking Nut And Torque Specifications
Courtesy of AMERICAN HONDA MOTOR CO., INC.

5. Hold the damper shaft with a hex wrench (C), and tighten the 10 mm self-locking nut to the specified torque value.

INSTALLATION

1. Position the damper (A) assembly in the body. Note the direction of the damper mounting base so the indent mark on it is toward the inside of the vehicle.

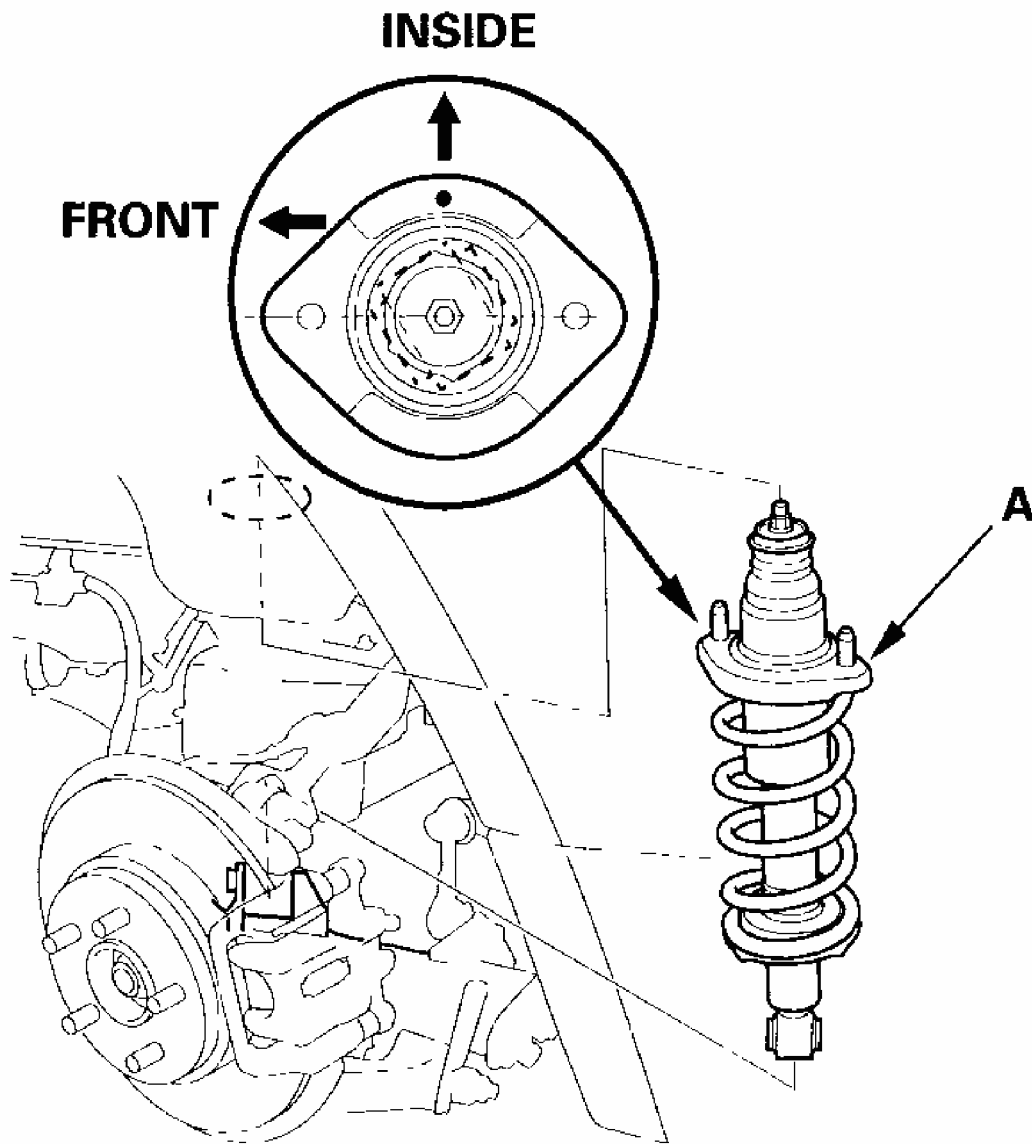

G03679144

Fig. 38: Positioning Damper Assembly Body
Courtesy of AMERICAN HONDA MOTOR CO., INC.

2. Loosely install the flange nuts (A) onto the top of the damper.

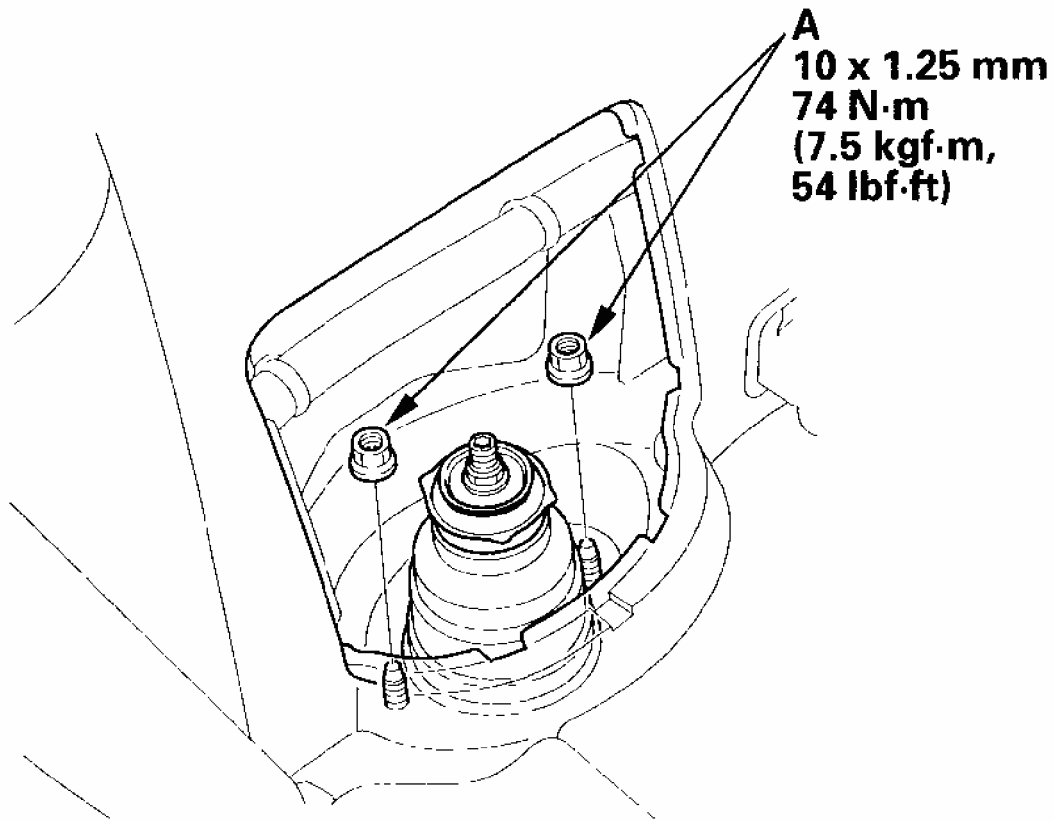

G03679145

**Fig. 39: Installing Flange Nuts Onto Top Of Damper And Torque Specifications
Courtesy of AMERICAN HONDA MOTOR CO., INC.**

3. Loosely install the flange bolt (A) on the bottom of the damper (B).

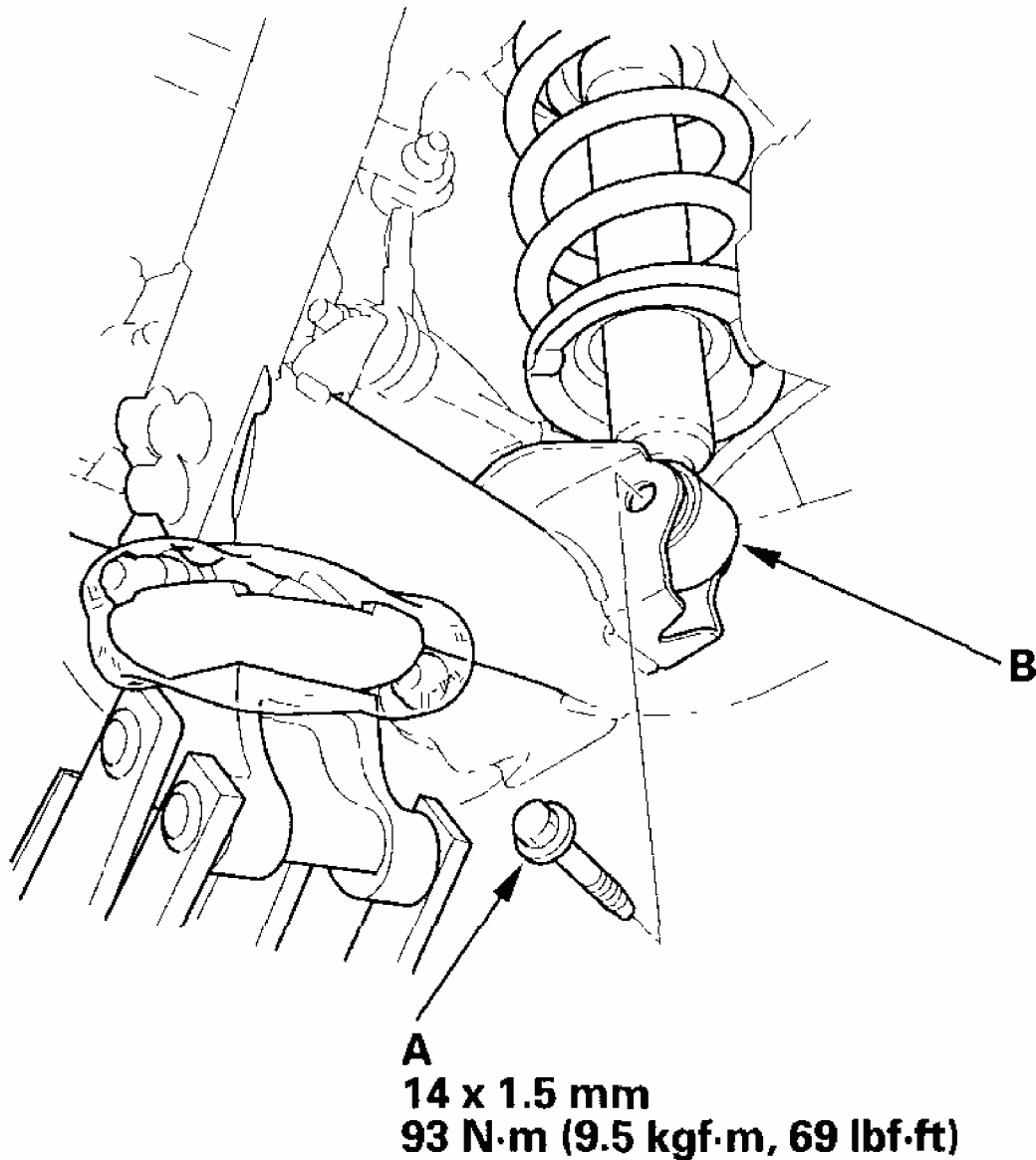

G03679146

Fig. 40: Installing Flange Bolt On Bottom Of Damper And Torque Specifications
Courtesy of AMERICAN HONDA MOTOR CO., INC.

4. Raise the suspension with a floor jack to load it with the vehicle's weight, and tighten the nuts and bolt to the specified torque values.
5. Install the EVAP canister mounting bolts (only left side) (see **EVAP CANISTER REPLACEMENT**).
6. Clean the mating surface of the brake disc/drum and the inside of the wheel, then install the rear wheel.

2004 Honda Element DX

2003-06 SUSPENSION Rear Suspension - Element

7. Check the wheel alignment, and adjust it if necessary (see **WHEEL ALIGNMENT**).