

# AIR CONDITIONING

# 2004 Honda Element DX

## 2004 SYSTEM WIRING DIAGRAMS Honda - Element

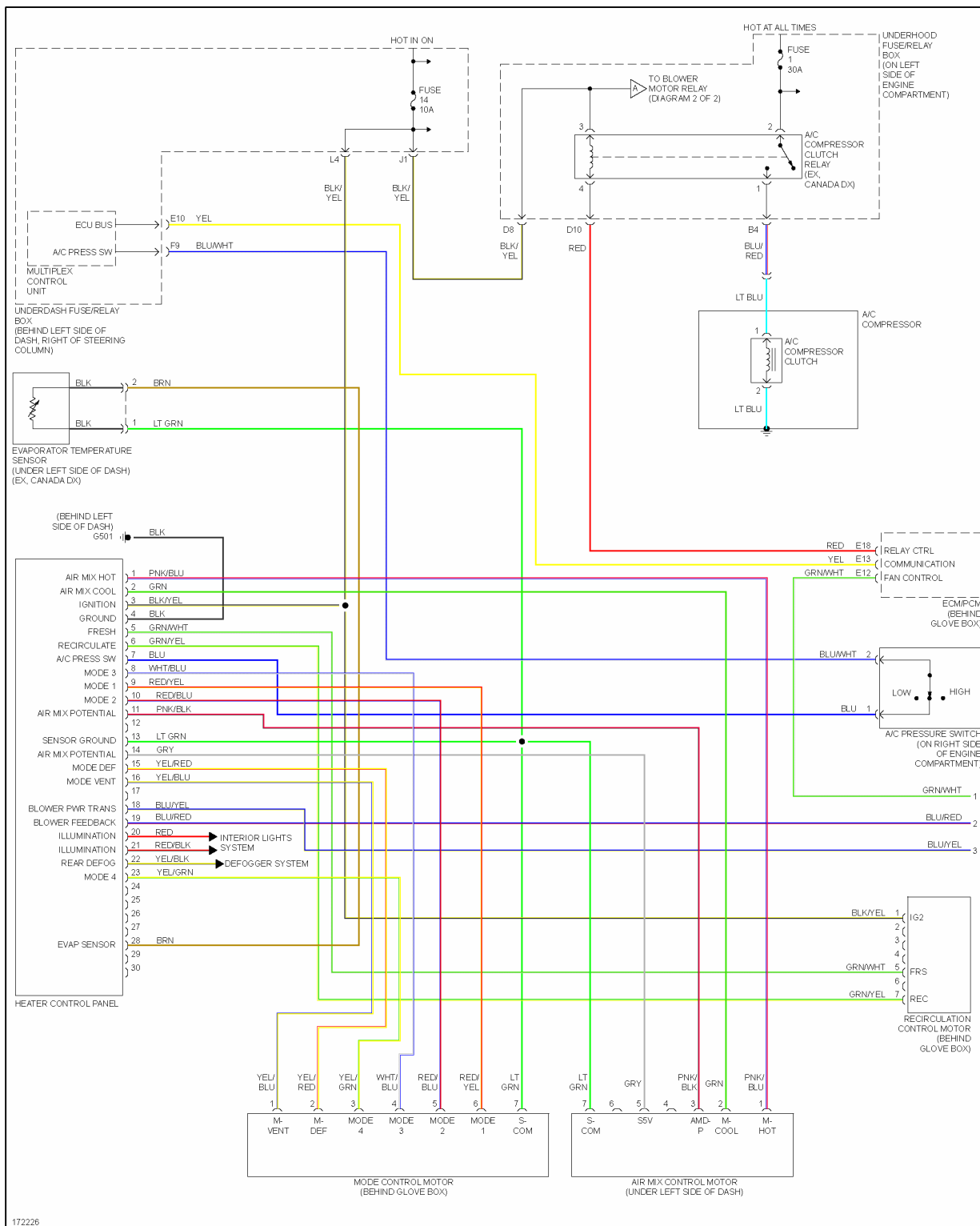

**Fig. 1: Manual A/C Circuit (1 of 2)**

# 2004 Honda Element DX

## 2004 SYSTEM WIRING DIAGRAMS Honda - Element

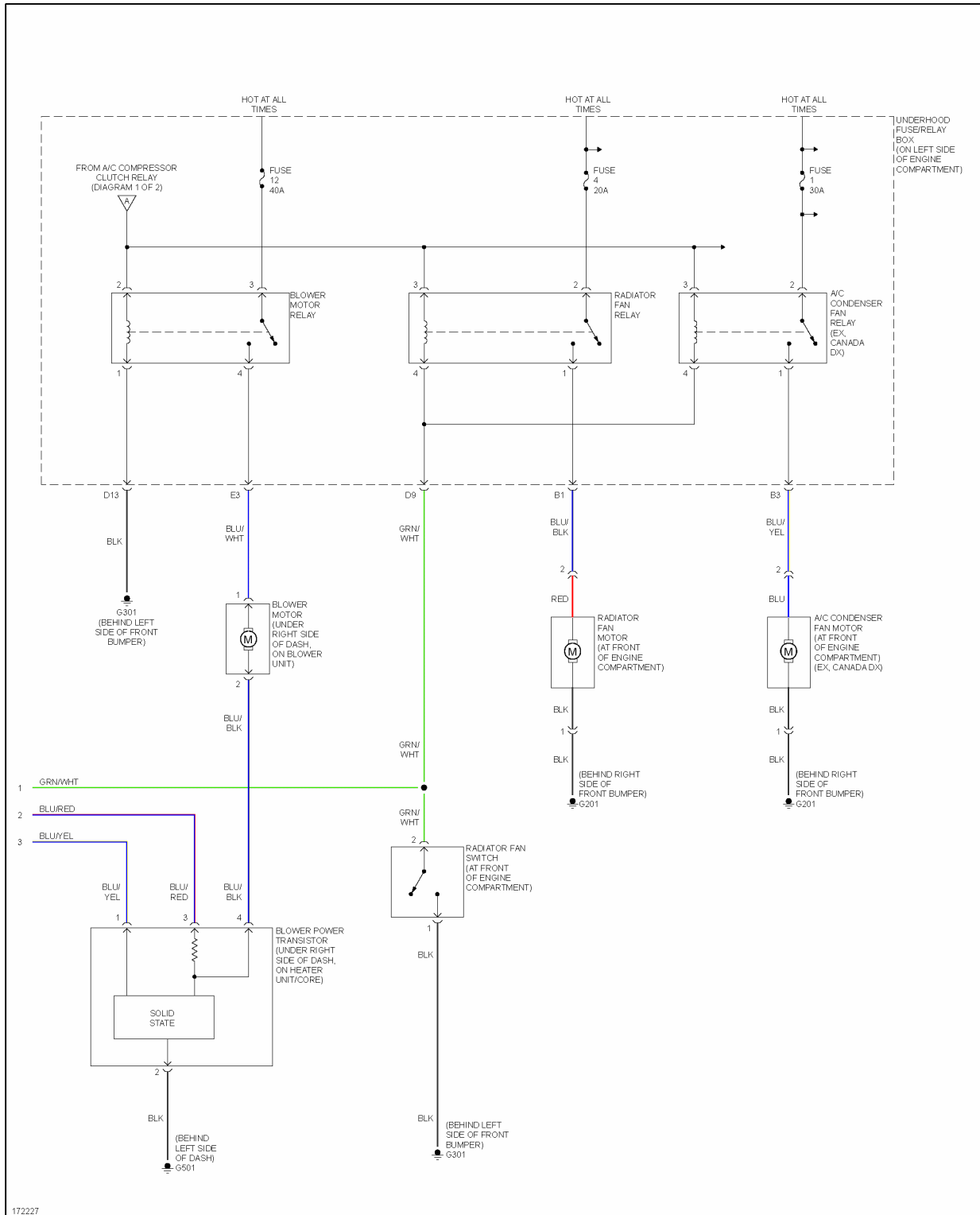

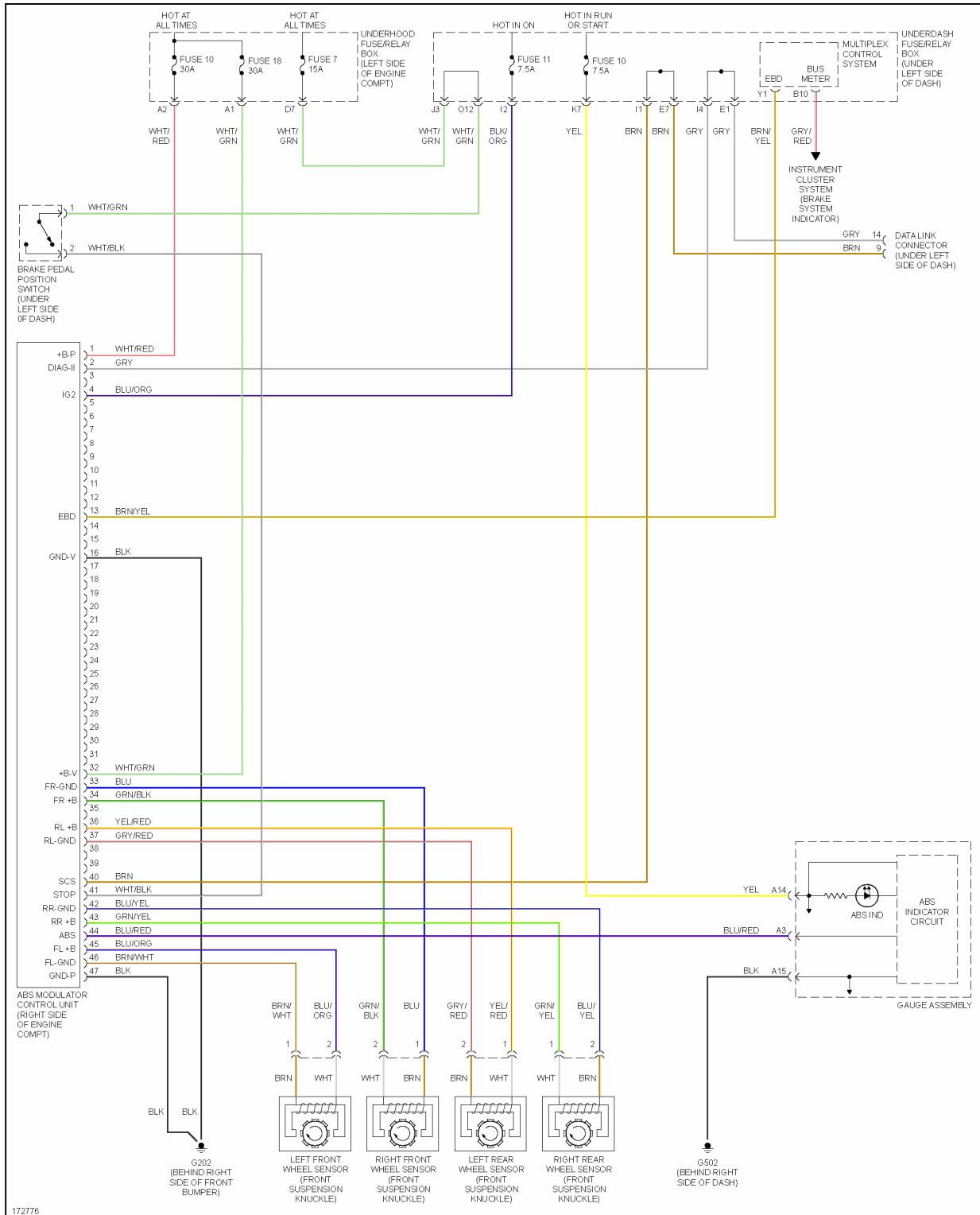

**Fig. 2: Manual A/C Circuit (2 of 2)**

**ANTI-LOCK BRAKES**

# 2004 Honda Element DX

## 2004 SYSTEM WIRING DIAGRAMS Honda - Element

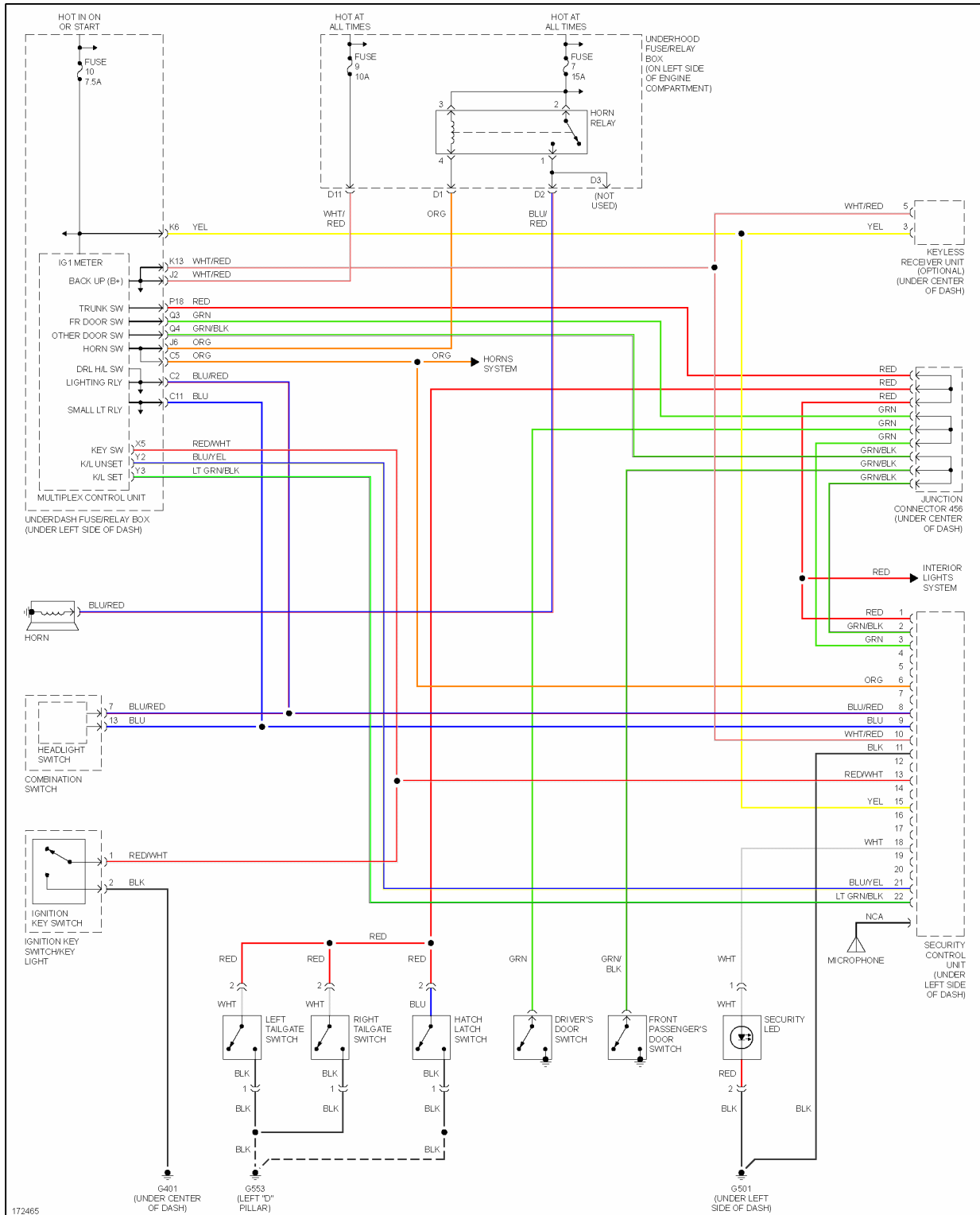

**Fig. 3: Anti-lock Brakes Circuit**

**ANTI-THEFT**

# 2004 Honda Element DX

## 2004 SYSTEM WIRING DIAGRAMS Honda - Element



**Fig. 4: Forced Entry Circuit**

# 2004 Honda Element DX

## 2004 SYSTEM WIRING DIAGRAMS Honda - Element

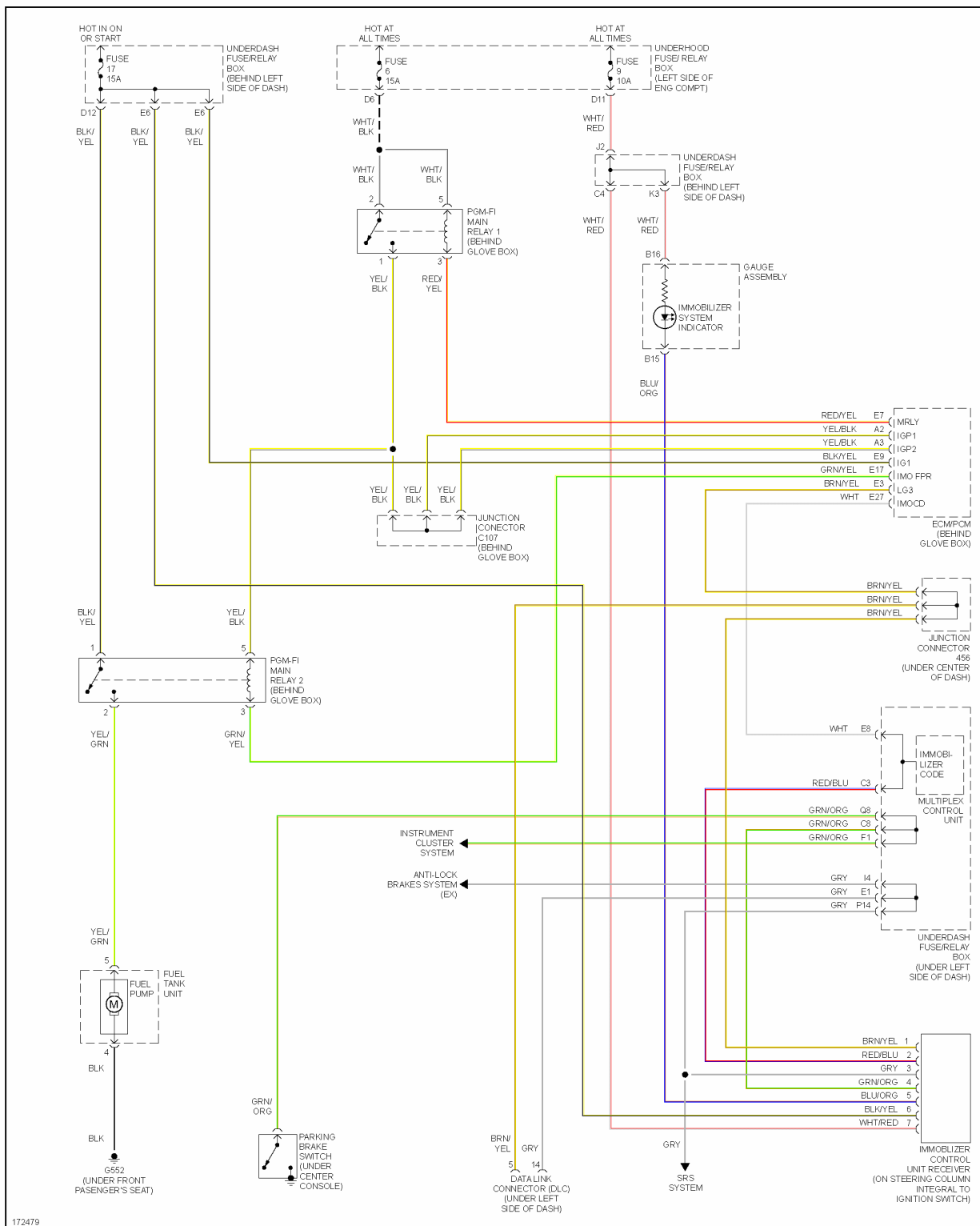

**Fig. 5: Immobilizer Circuit**

**BODY CONTROL MODULES**



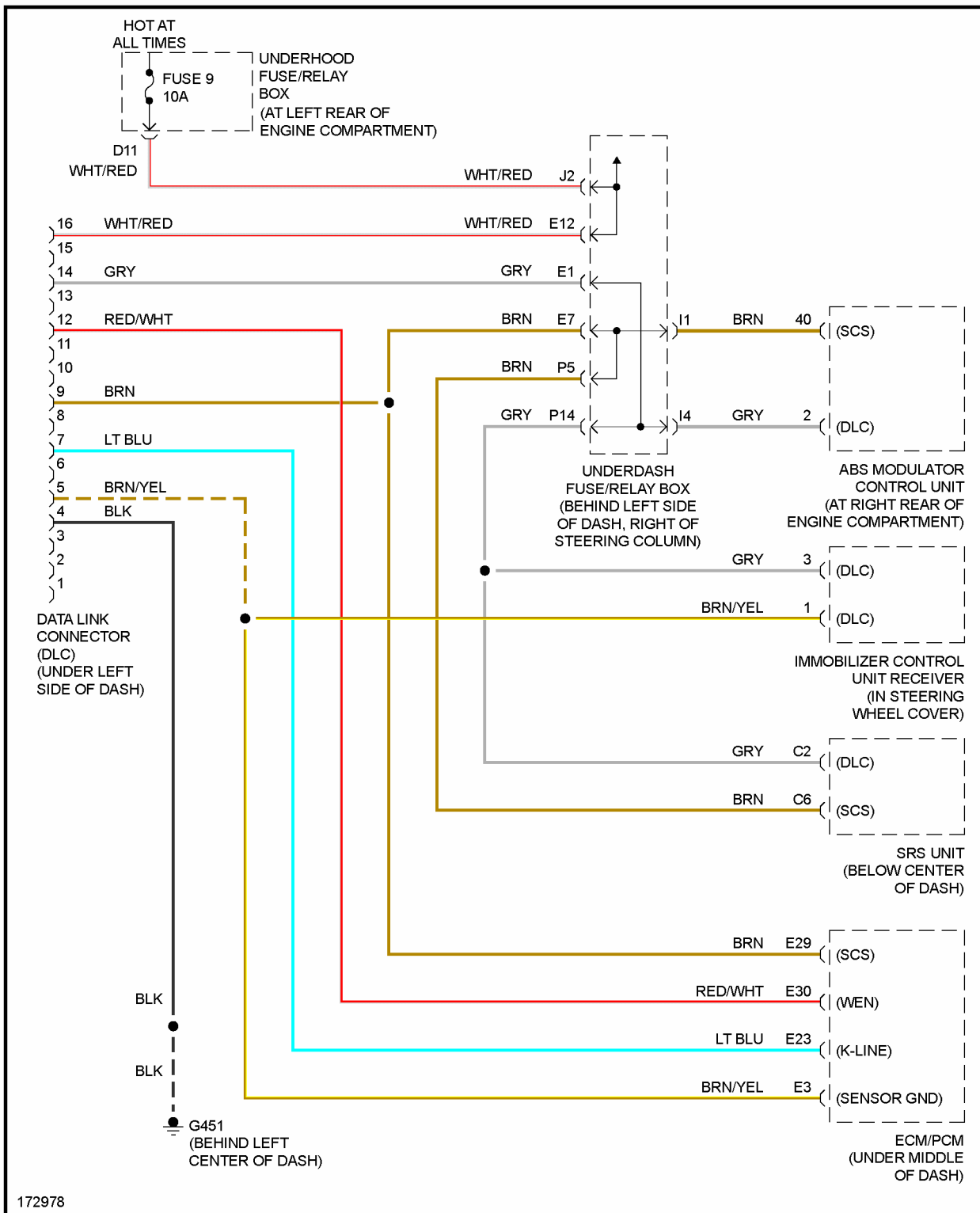

**Fig. 6: Body Control Modules Circuit**

**COMPUTER DATA LINES**

# 2004 Honda Element DX

## 2004 SYSTEM WIRING DIAGRAMS Honda - Element

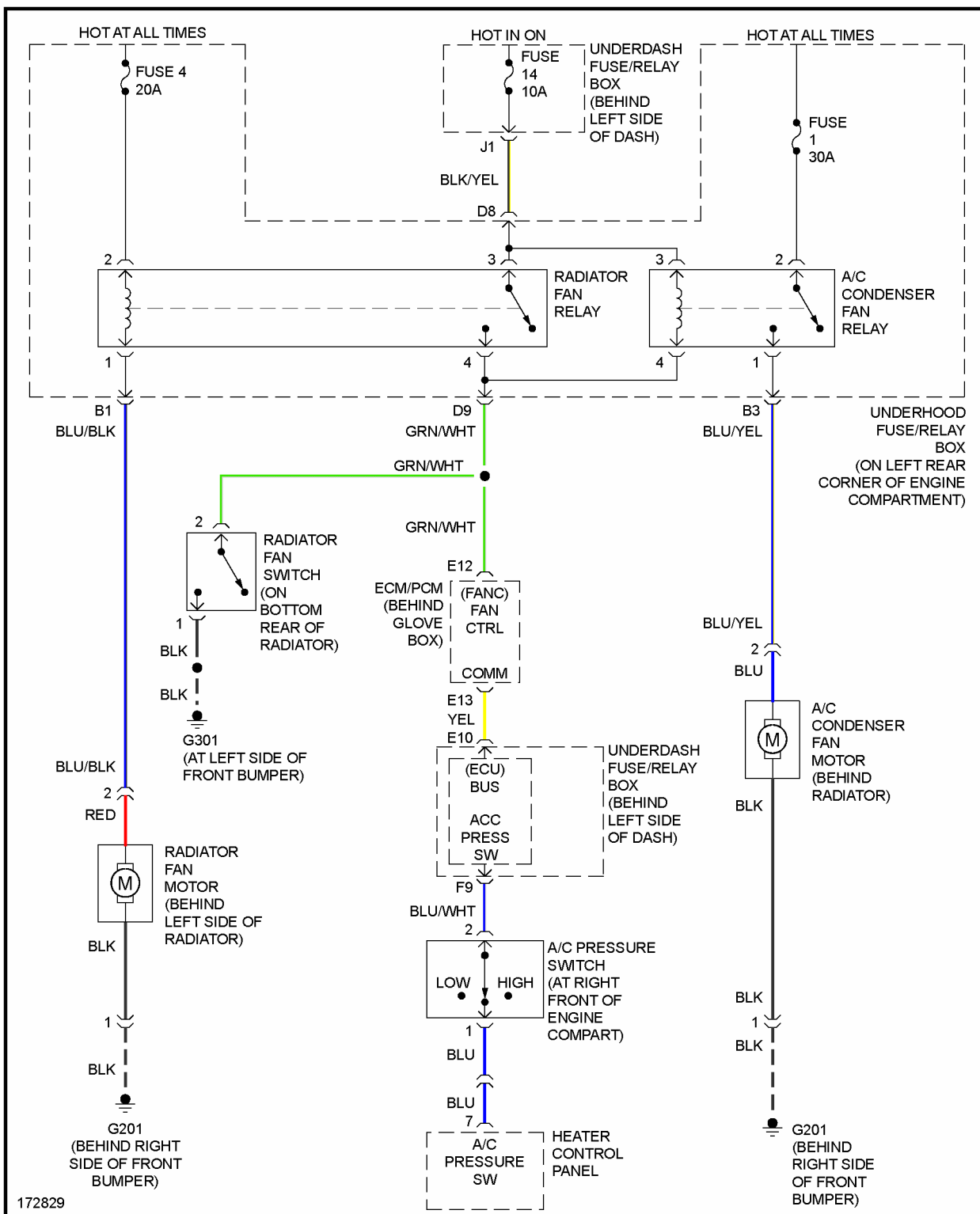

**Fig. 7: Data Link Connector Circuit**

**COOLING FAN**

# 2004 Honda Element DX

## 2004 SYSTEM WIRING DIAGRAMS Honda - Element

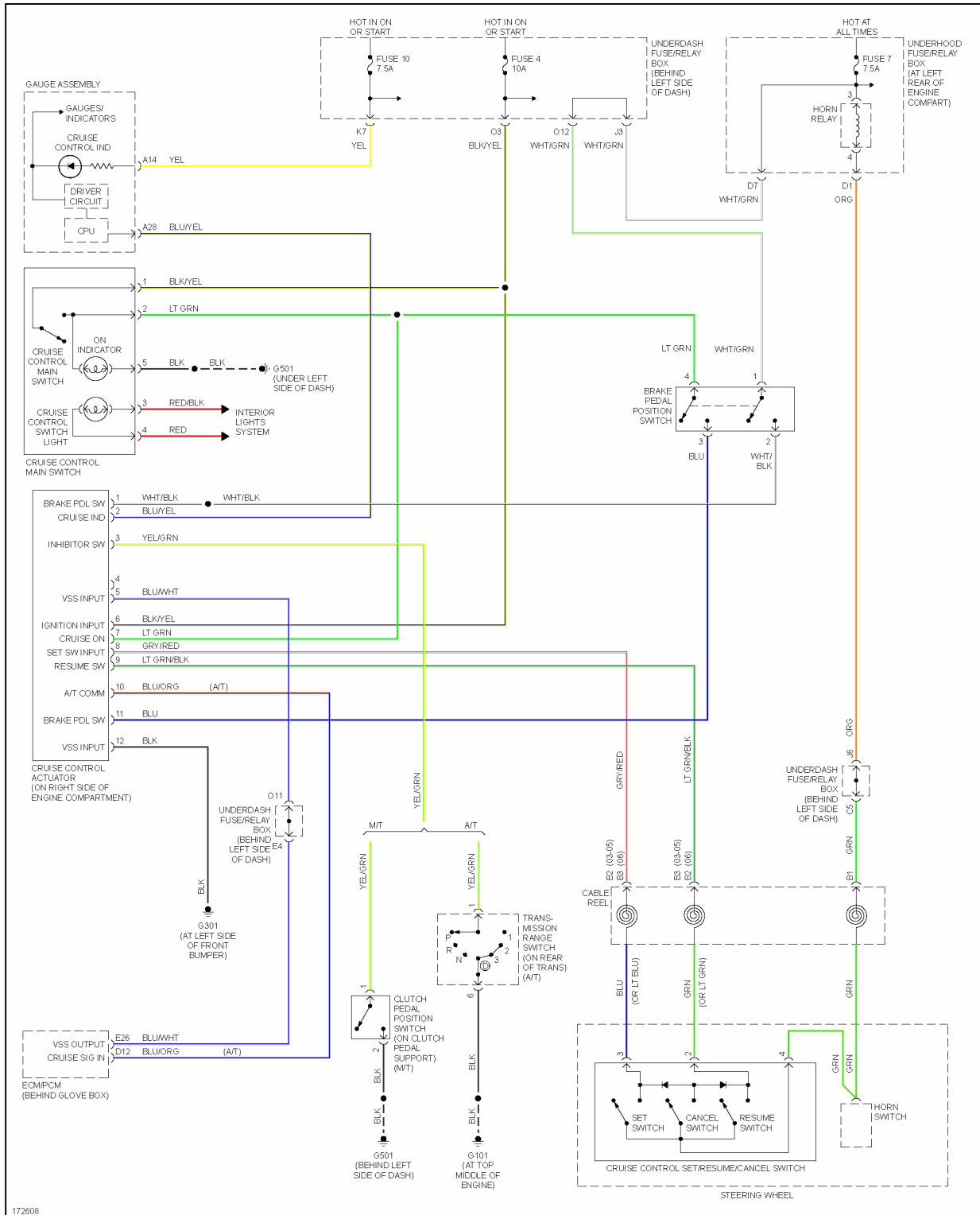

**Fig. 8: Cooling Fan Circuit**

**CRUISE CONTROL**

# 2004 Honda Element DX

## 2004 SYSTEM WIRING DIAGRAMS Honda - Element

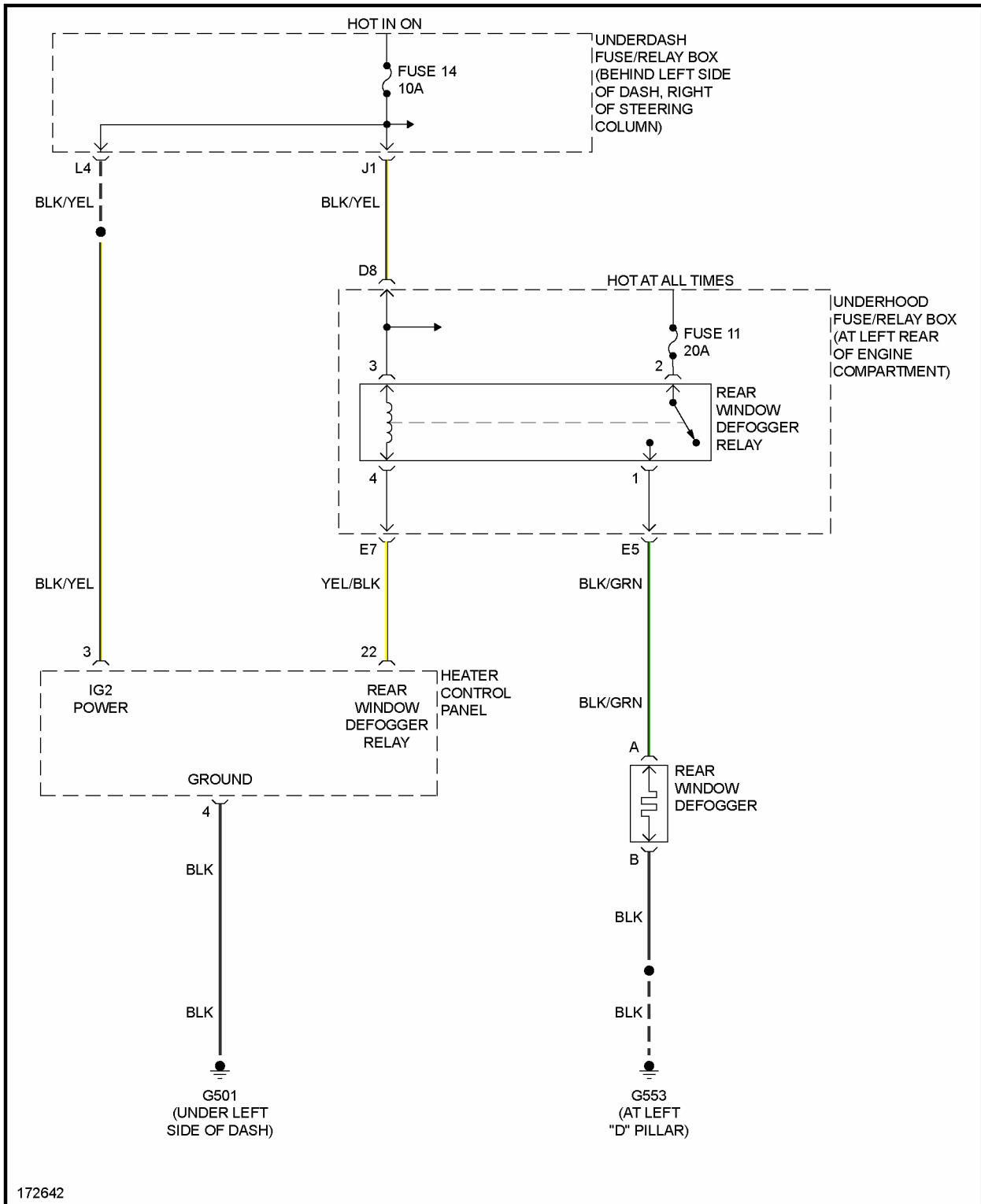

**Fig. 9: Cruise Control Circuit**

**DEFOGGERS**

# 2004 Honda Element DX

## 2004 SYSTEM WIRING DIAGRAMS Honda - Element





**Fig. 10: Defoggers Circuit**

**ENGINE PERFORMANCE**

2.4L



**Fig. 11: 2.4L, Engine Performance Circuit (1 of 3)**

# 2004 Honda Element DX

## 2004 SYSTEM WIRING DIAGRAMS Honda - Element

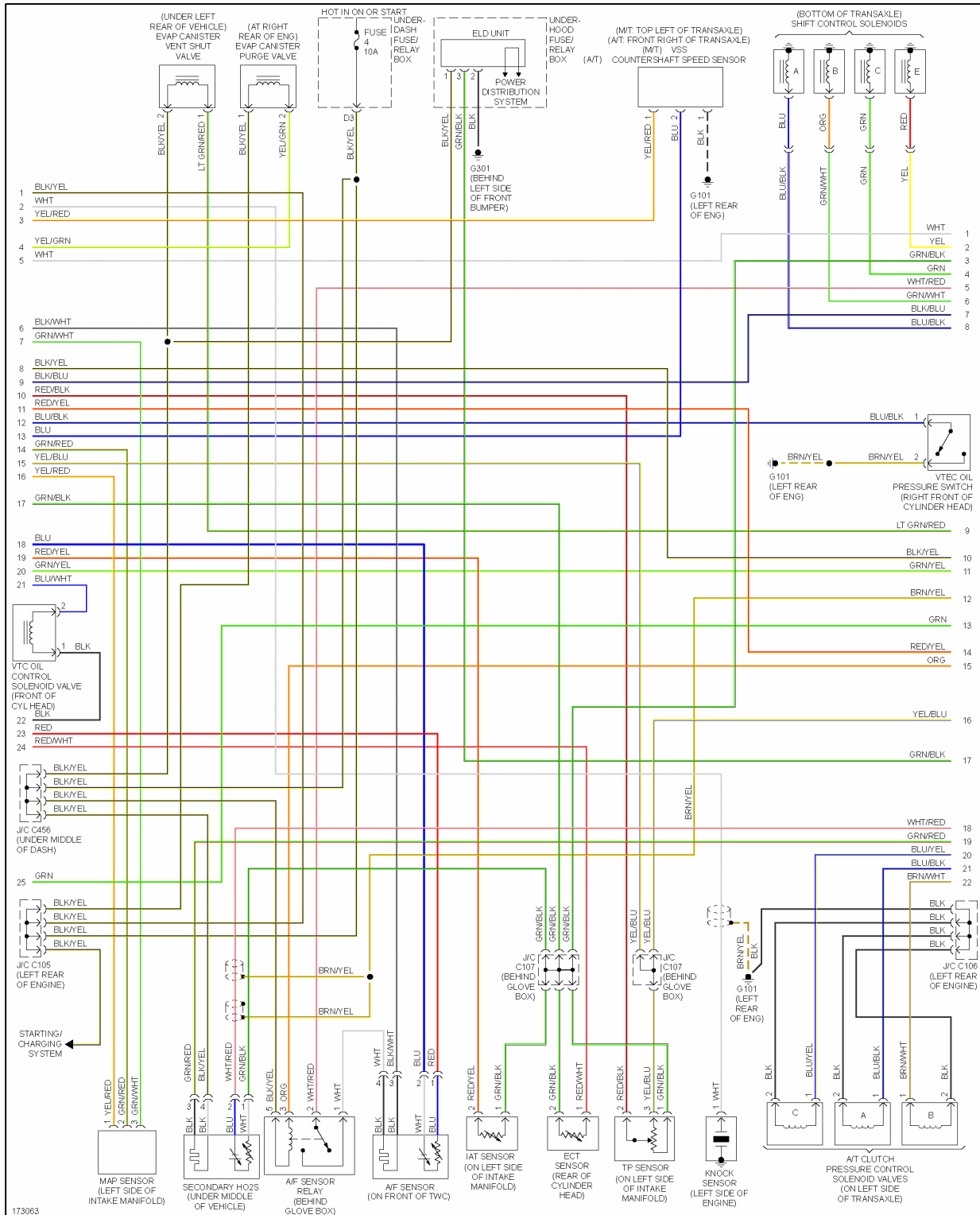

**Fig. 12: 2.4L, Engine Performance Circuit (2 of 3)**

# 2004 Honda Element DX

## 2004 SYSTEM WIRING DIAGRAMS Honda - Element

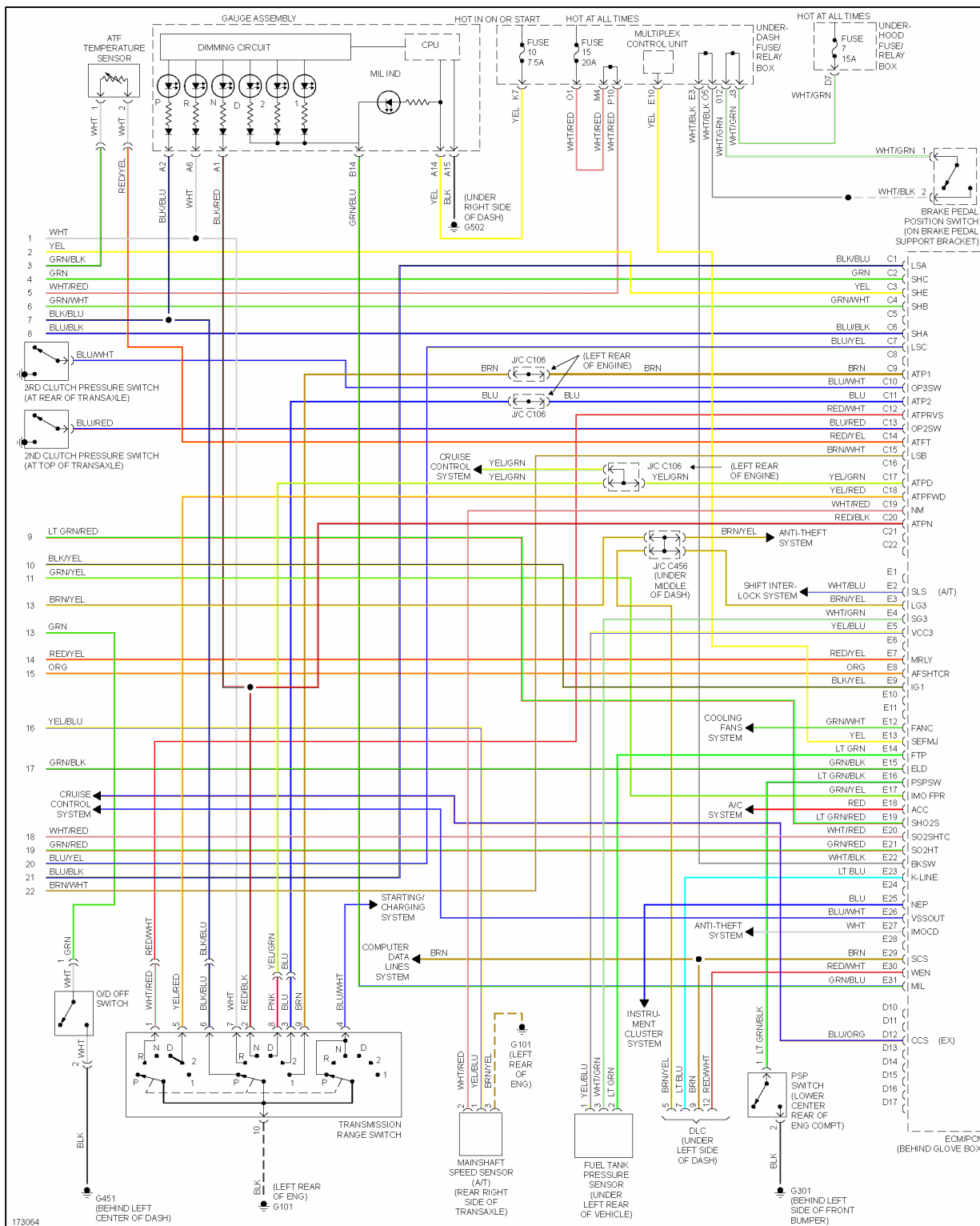
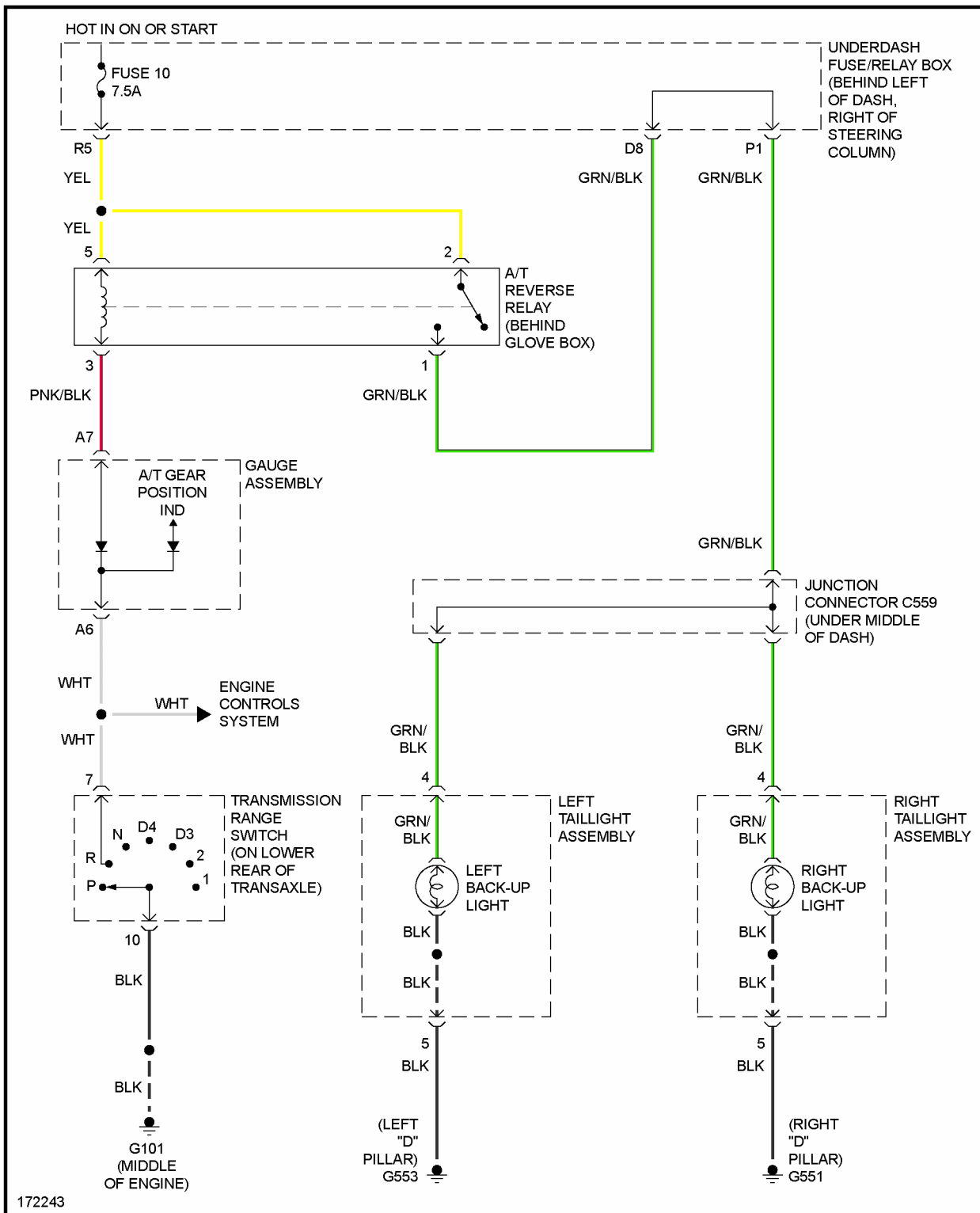

**Fig. 13: 2.4L, Engine Performance Circuit (3 of 3)**

**EXTERIOR LIGHTS**

# 2004 Honda Element DX

## 2004 SYSTEM WIRING DIAGRAMS Honda - Element

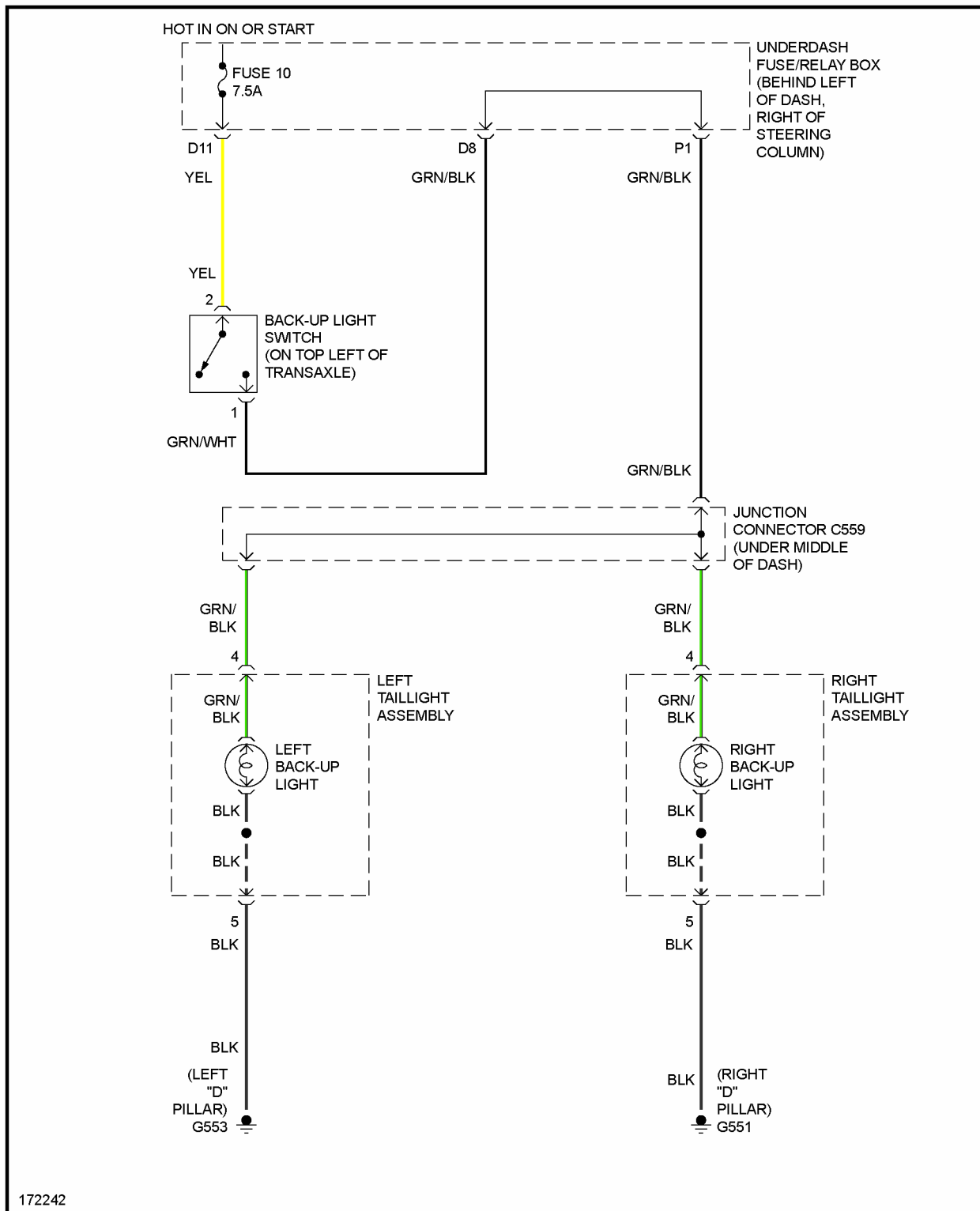



**Fig. 14: Back-up Lamps Circuit, A/T**

# 2004 Honda Element DX

## 2004 SYSTEM WIRING DIAGRAMS Honda - Element



**Fig. 15: Back-up Lamps Circuit, M/T**

# 2004 Honda Element DX

## 2004 SYSTEM WIRING DIAGRAMS Honda - Element

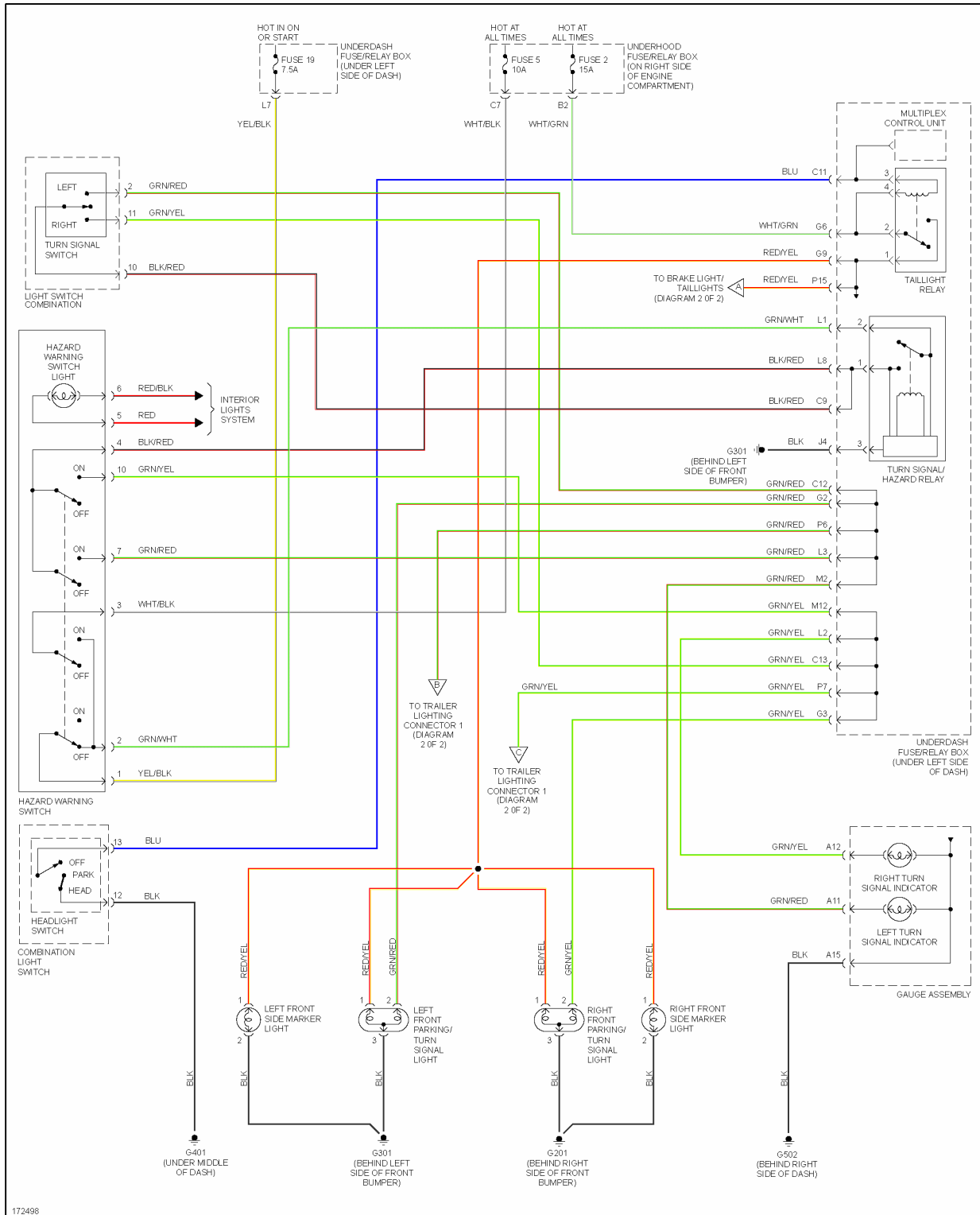

**Fig. 16: Exterior Lamps Circuit (1 of 2)**

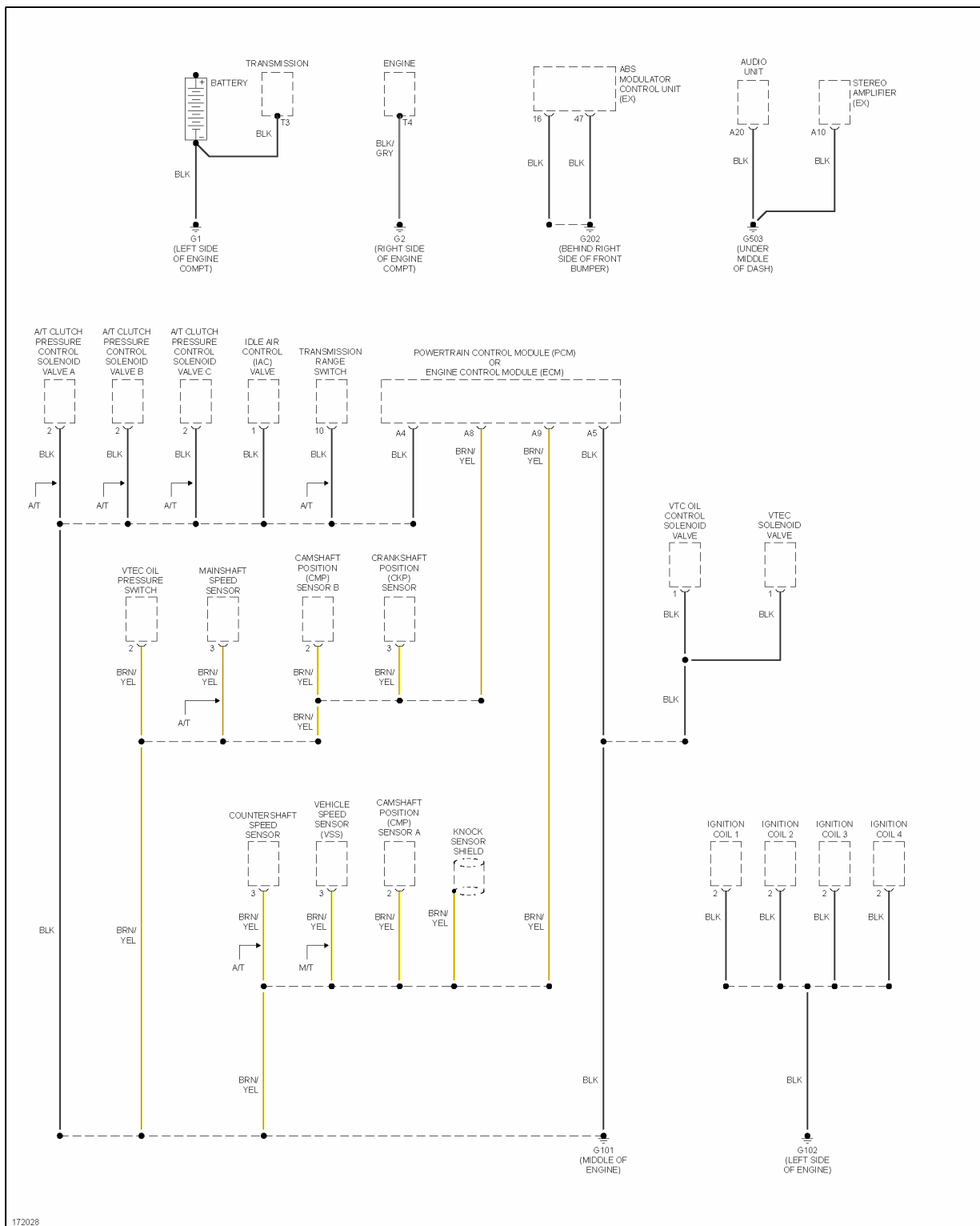

**Fig. 17: Exterior Lamps Circuit (2 of 2)**

**GROUND DISTRIBUTION**

# 2004 Honda Element DX

## 2004 SYSTEM WIRING DIAGRAMS Honda - Element

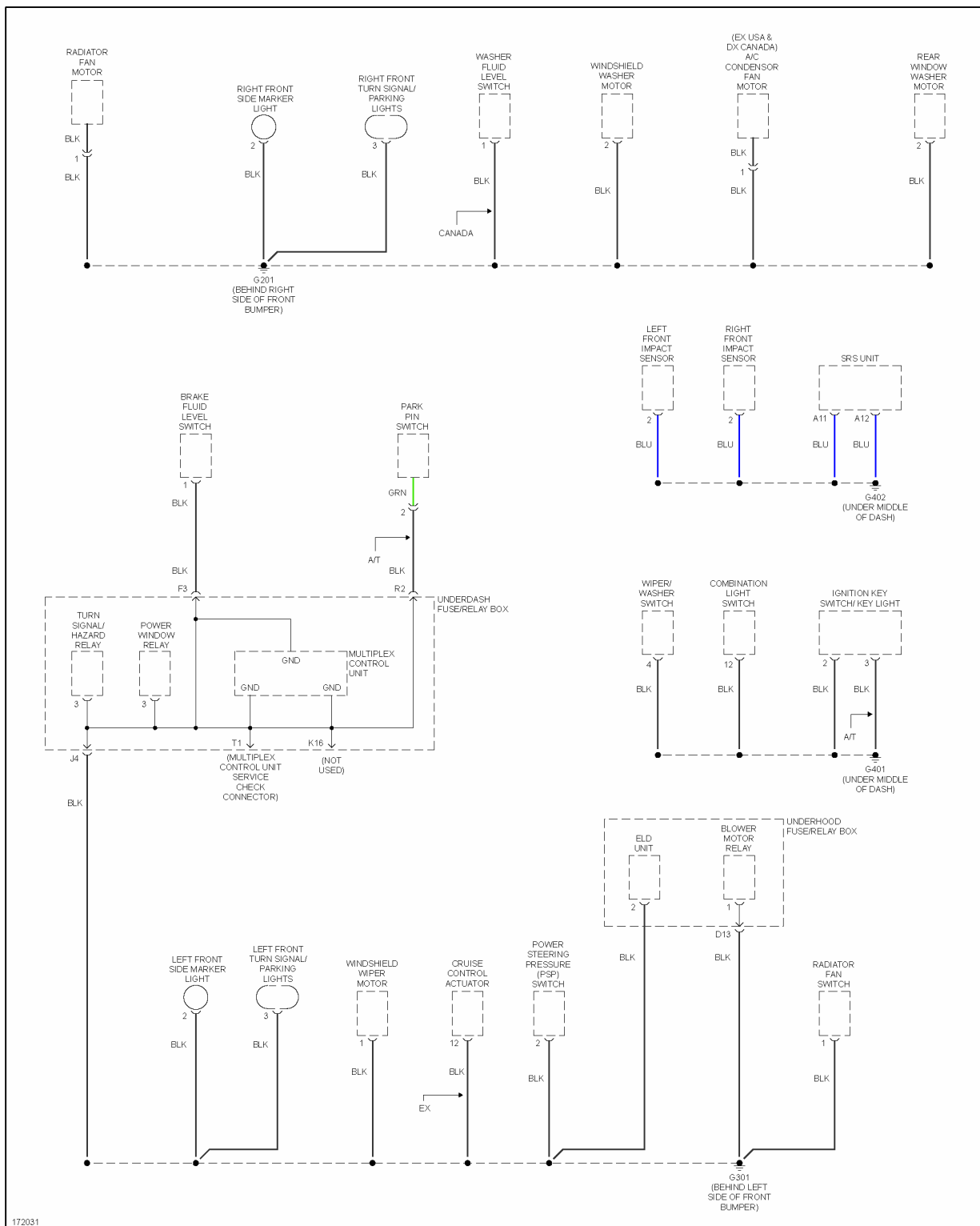



**Fig. 18: Ground Distribution Circuit (1 of 4)**

# 2004 Honda Element DX

## 2004 SYSTEM WIRING DIAGRAMS Honda - Element



**Fig. 19: Ground Distribution Circuit (2 of 4)**

# 2004 Honda Element DX

## 2004 SYSTEM WIRING DIAGRAMS Honda - Element

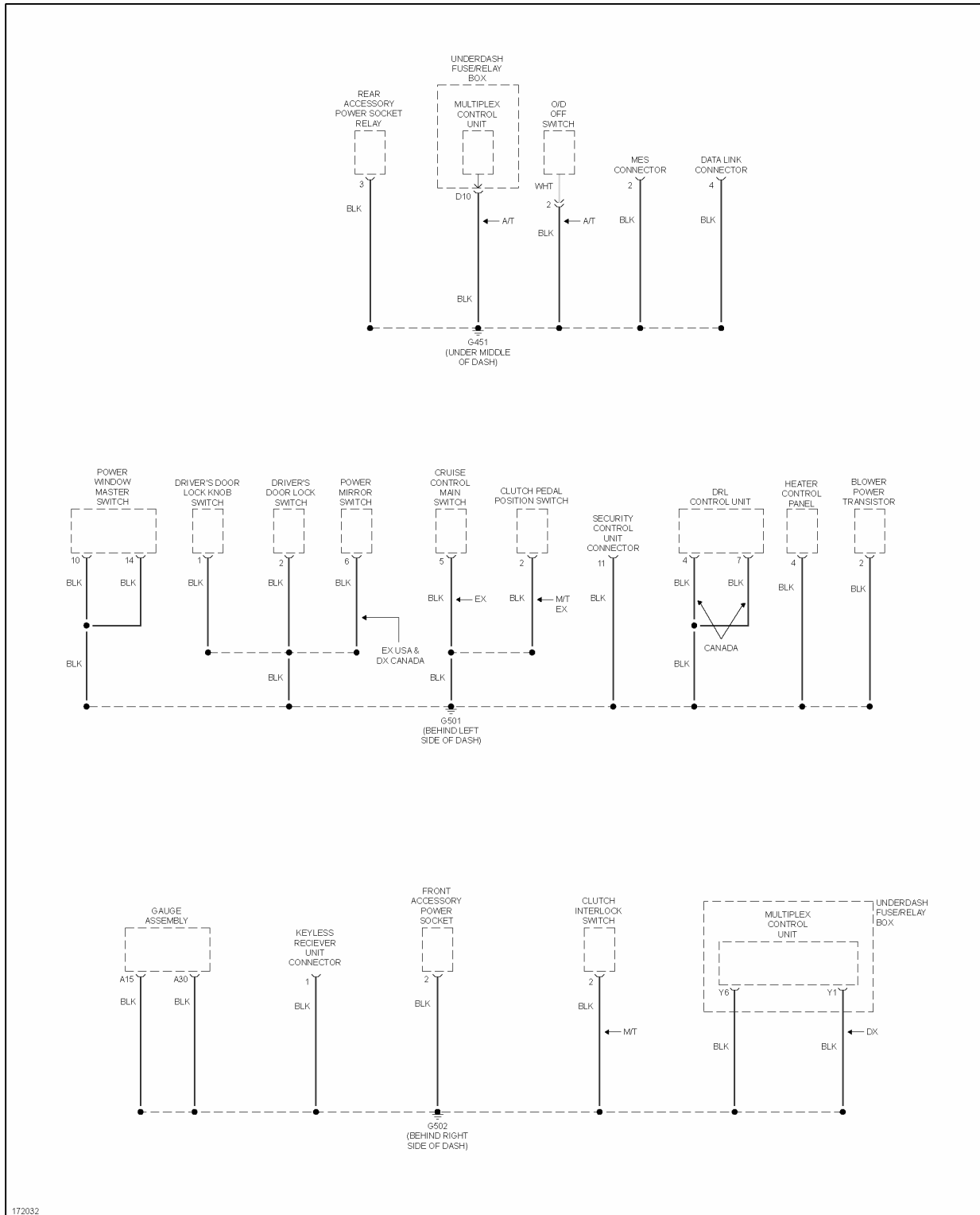

**Fig. 20: Ground Distribution Circuit (3 of 4)**

# 2004 Honda Element DX

## 2004 SYSTEM WIRING DIAGRAMS Honda - Element

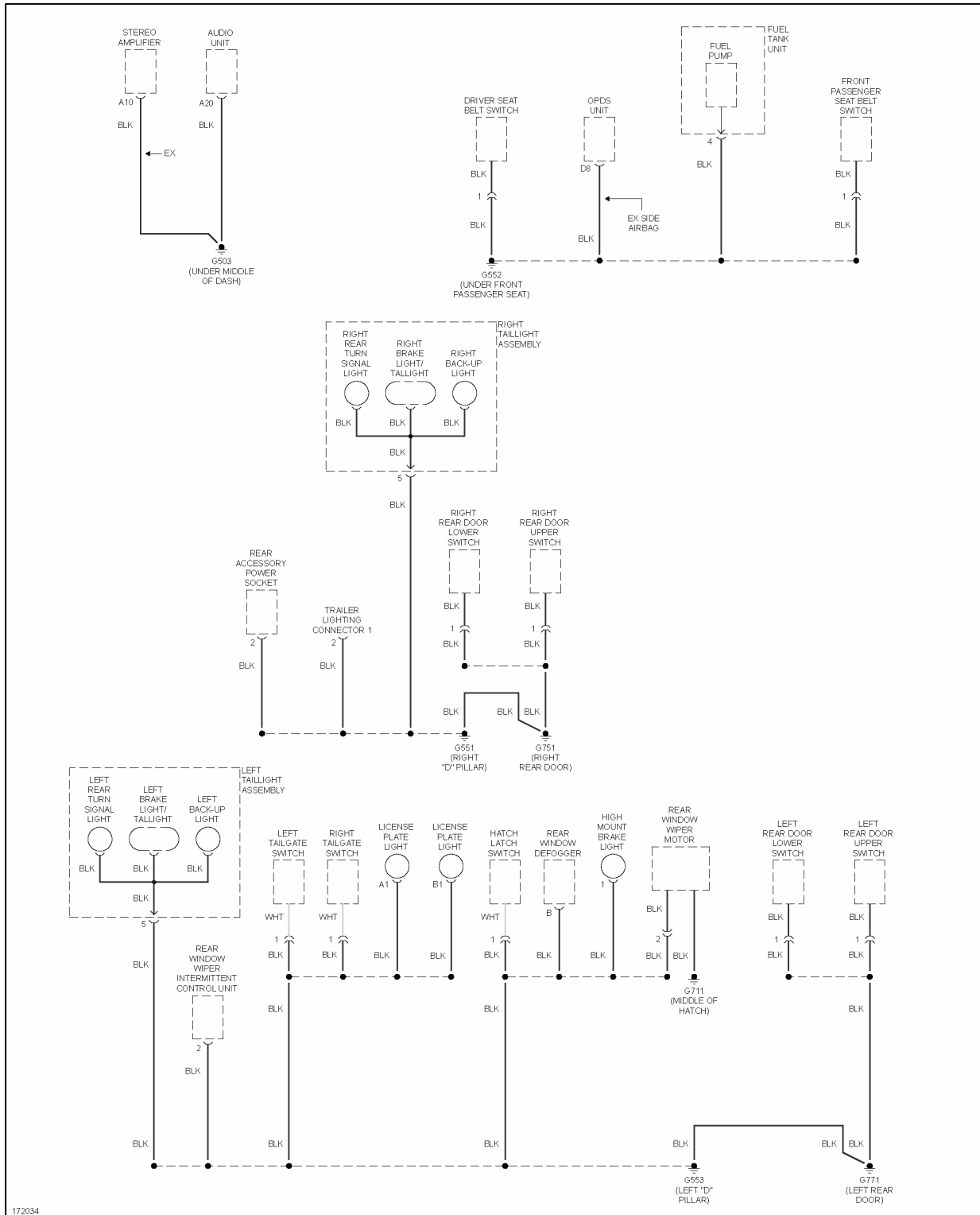
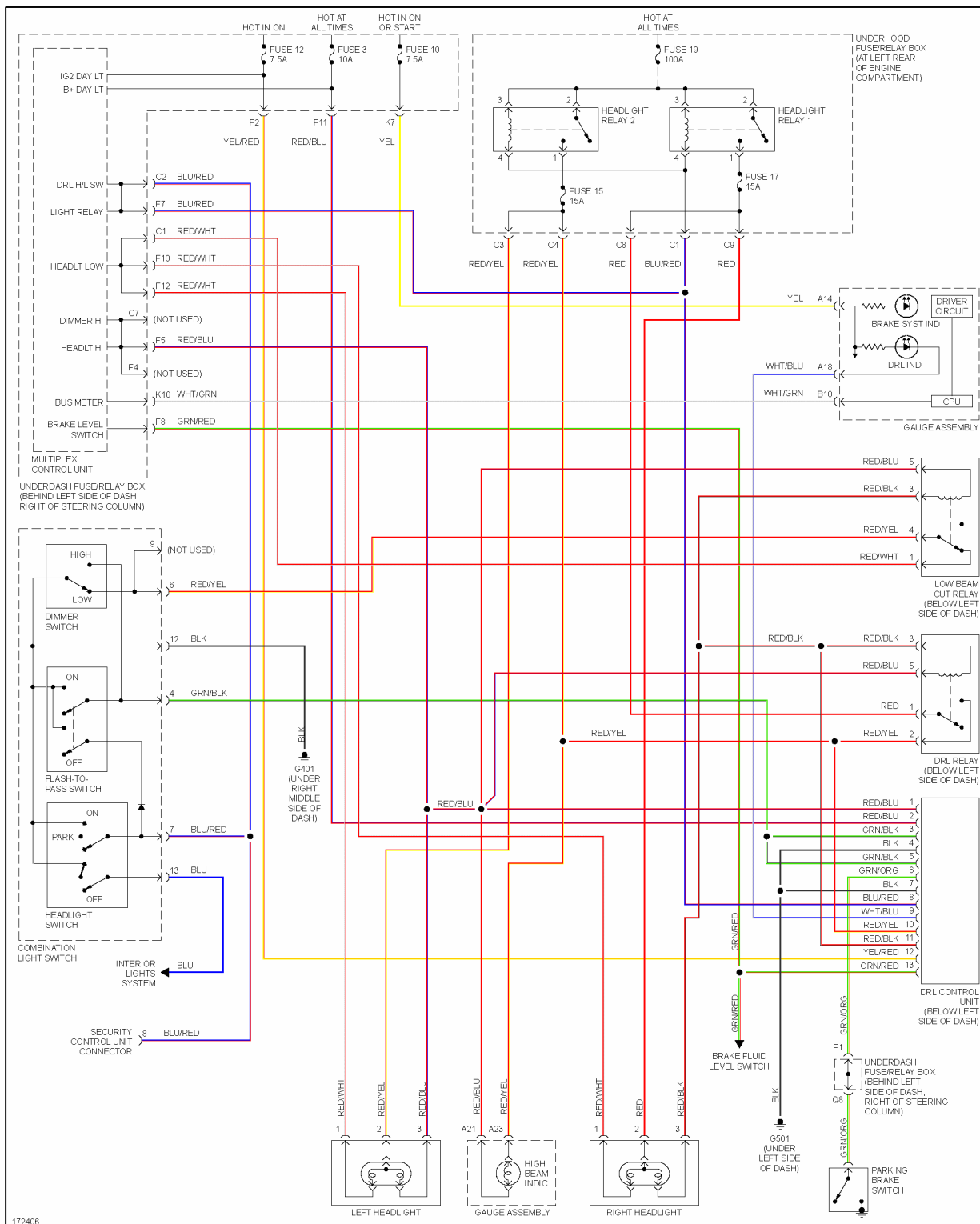

**Fig. 21: Ground Distribution Circuit (4 of 4)**

**HEADLIGHTS**

# 2004 Honda Element DX

## 2004 SYSTEM WIRING DIAGRAMS Honda - Element

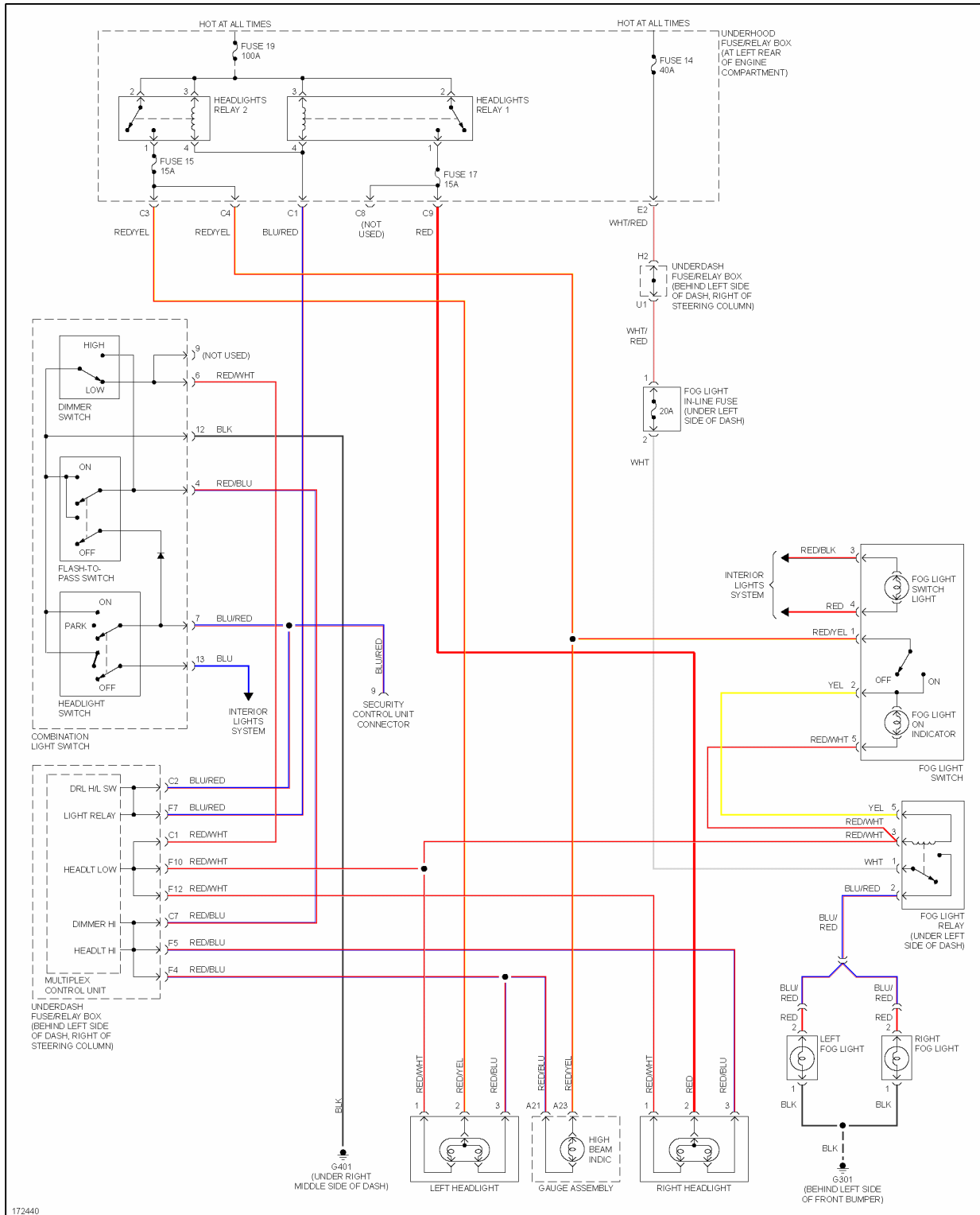



**Fig. 22: Headlights Circuit, W/ DRL**

# 2004 Honda Element DX

## 2004 SYSTEM WIRING DIAGRAMS Honda - Element

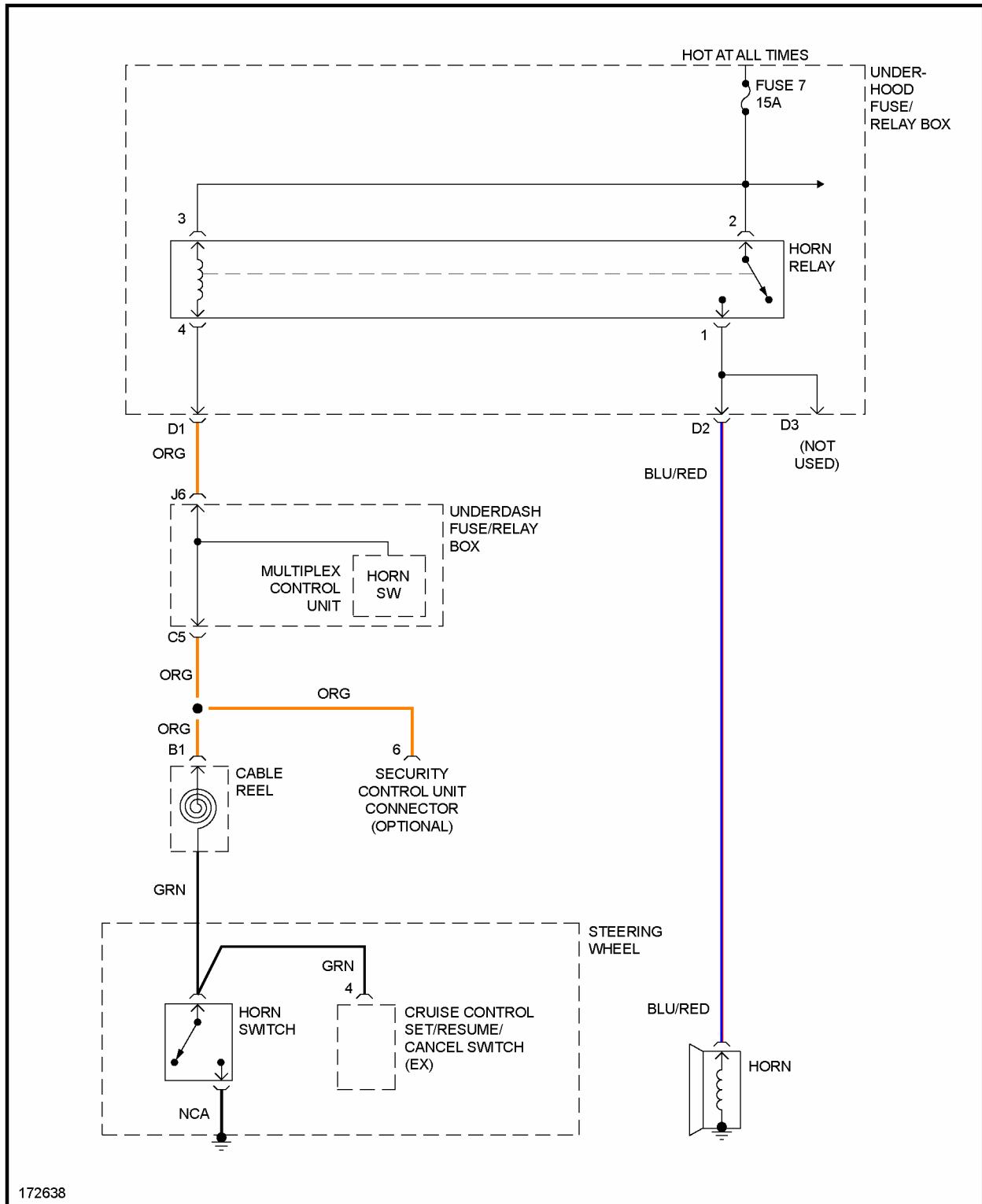

**Fig. 23: Headlights Circuit, W/O DRL**

**HORN**

# 2004 Honda Element DX

## 2004 SYSTEM WIRING DIAGRAMS Honda - Element

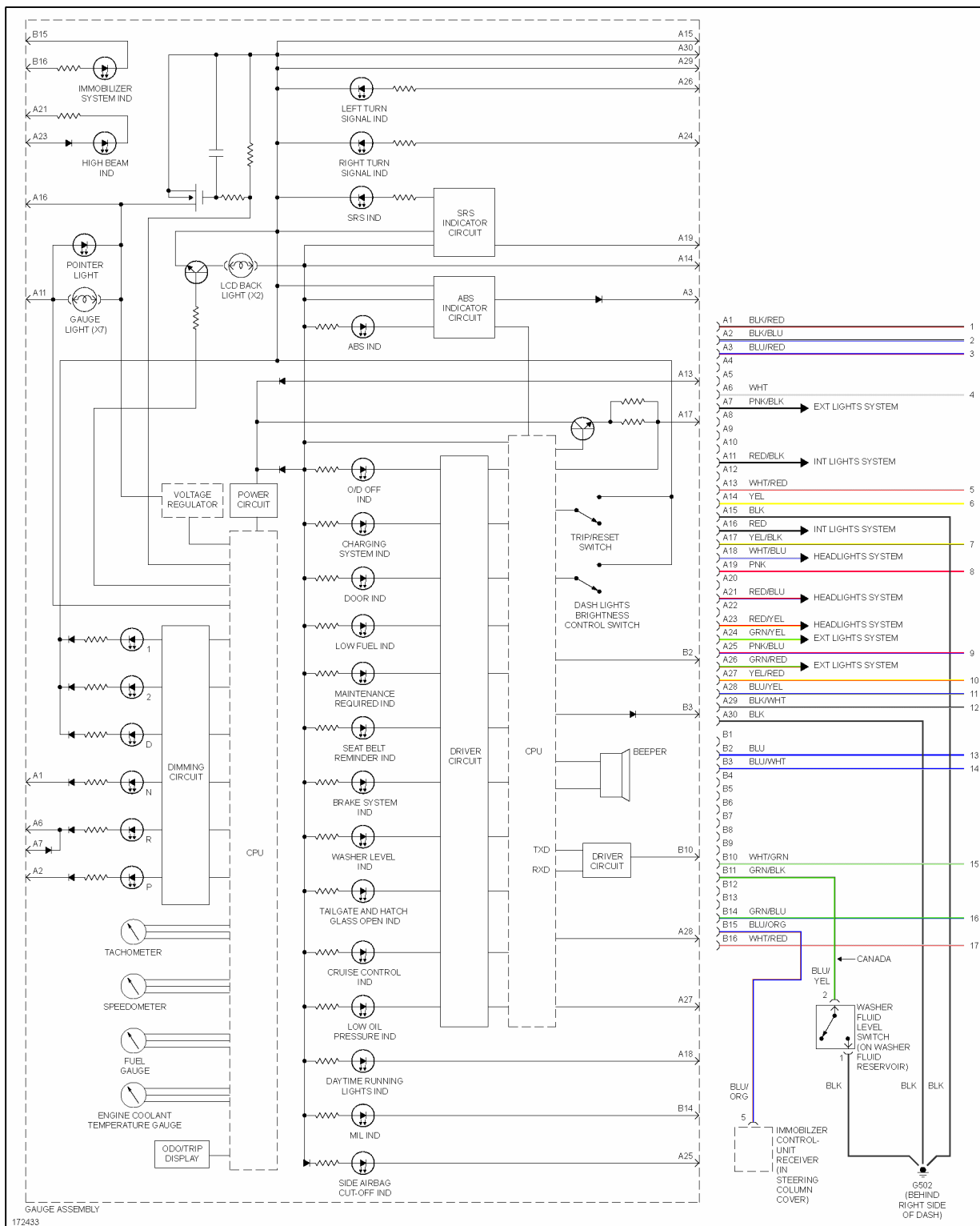

**Fig. 24: Horn Circuit**

**INSTRUMENT CLUSTER**

# 2004 Honda Element DX

## 2004 SYSTEM WIRING DIAGRAMS Honda - Element



**Fig. 25: Instrument Cluster Circuit (1 of 2)**

# 2004 Honda Element DX

## 2004 SYSTEM WIRING DIAGRAMS Honda - Element

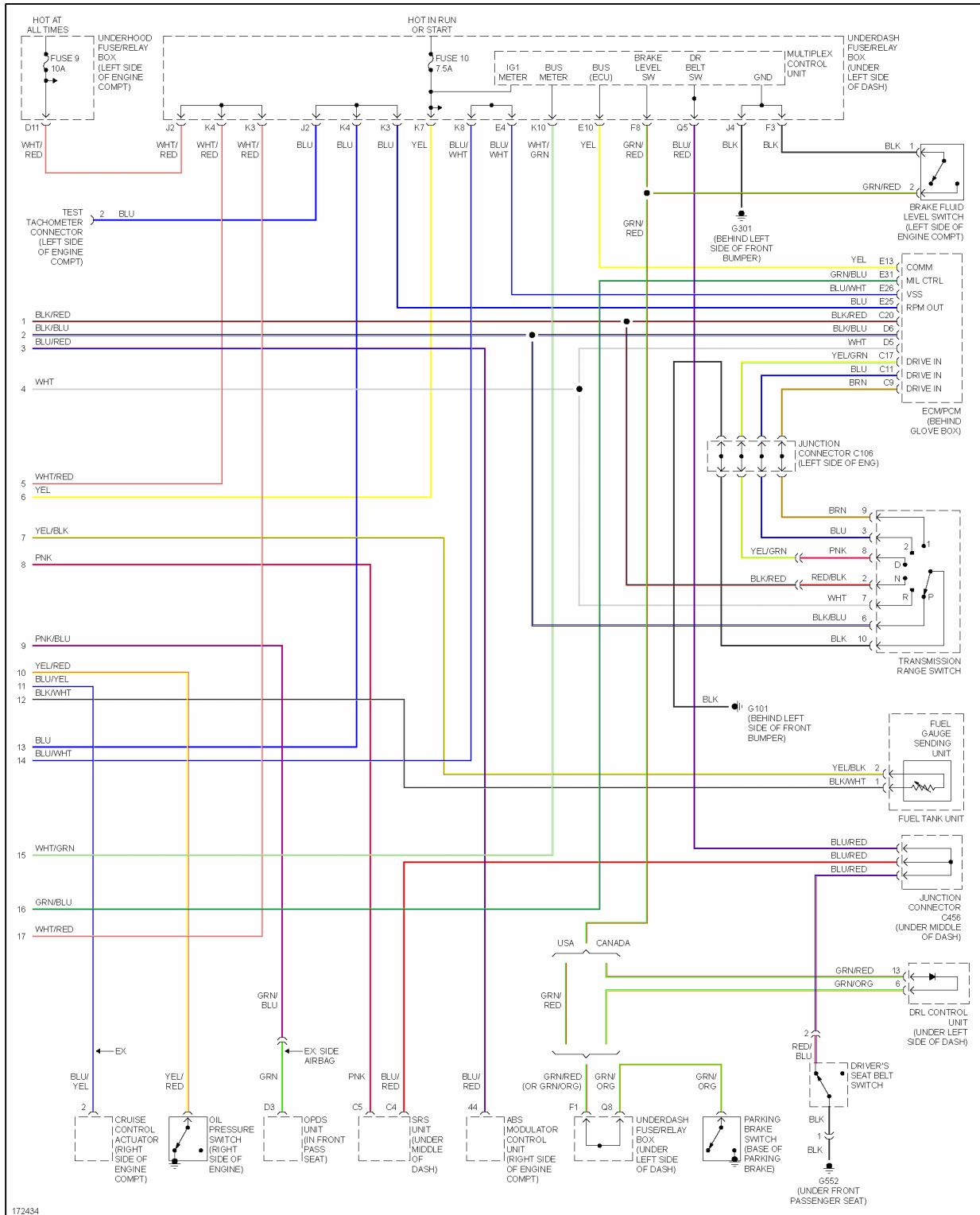

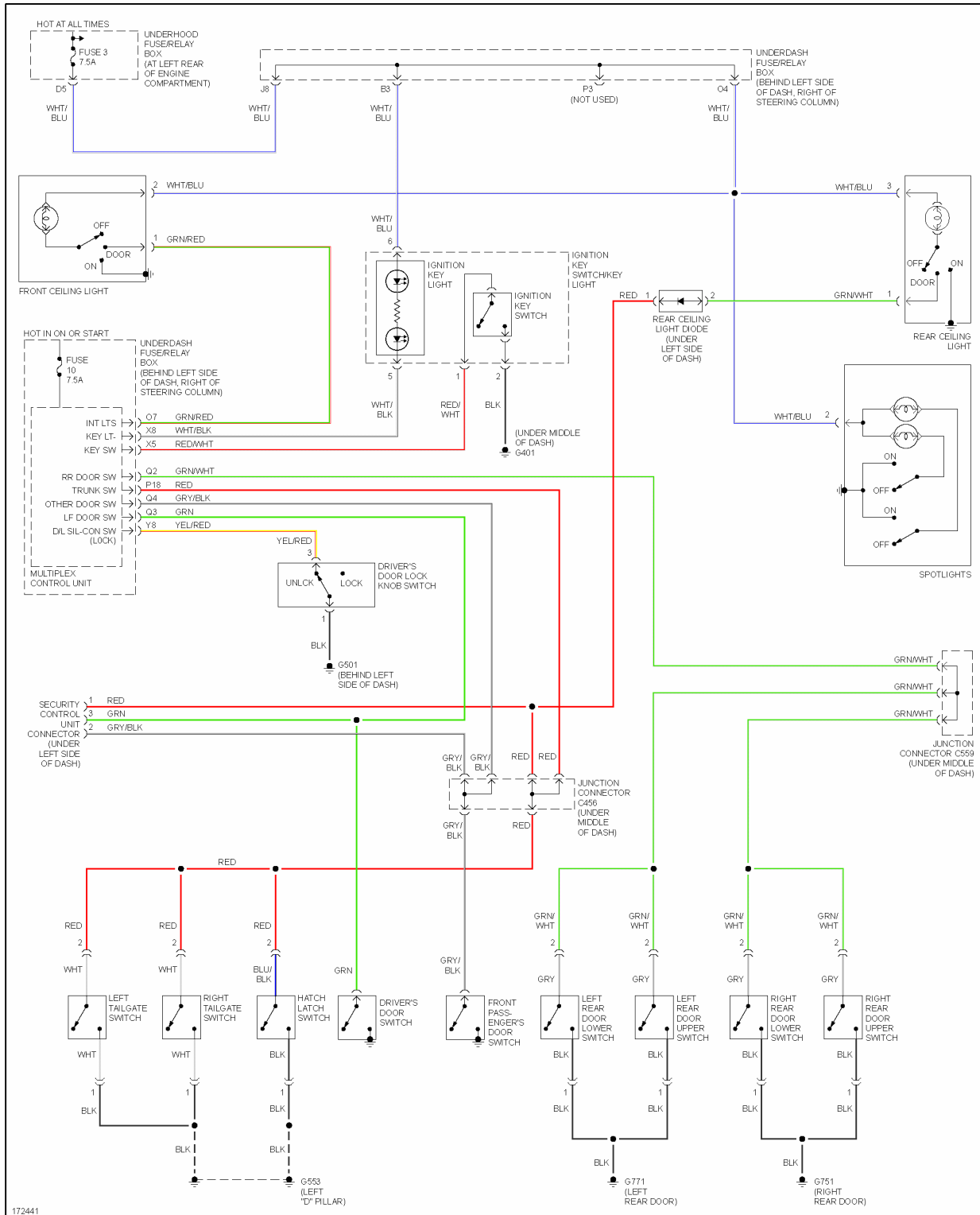

**Fig. 26: Instrument Cluster Circuit (2 of 2)**

**INTERIOR LIGHTS**

# 2004 Honda Element DX

## 2004 SYSTEM WIRING DIAGRAMS Honda - Element



**Fig. 27: Courtesy Lamp Circuit**

# 2004 Honda Element DX

## 2004 SYSTEM WIRING DIAGRAMS Honda - Element

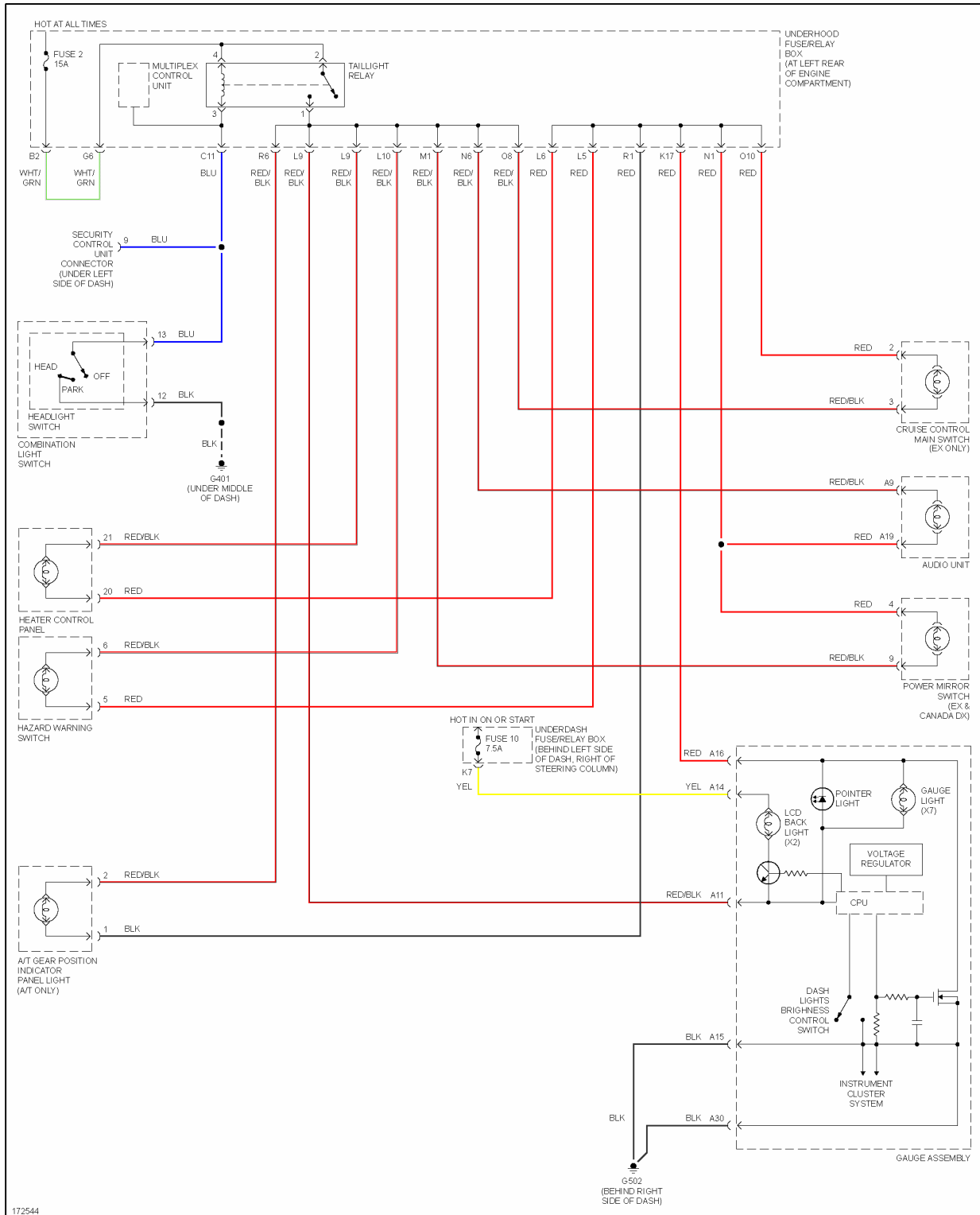
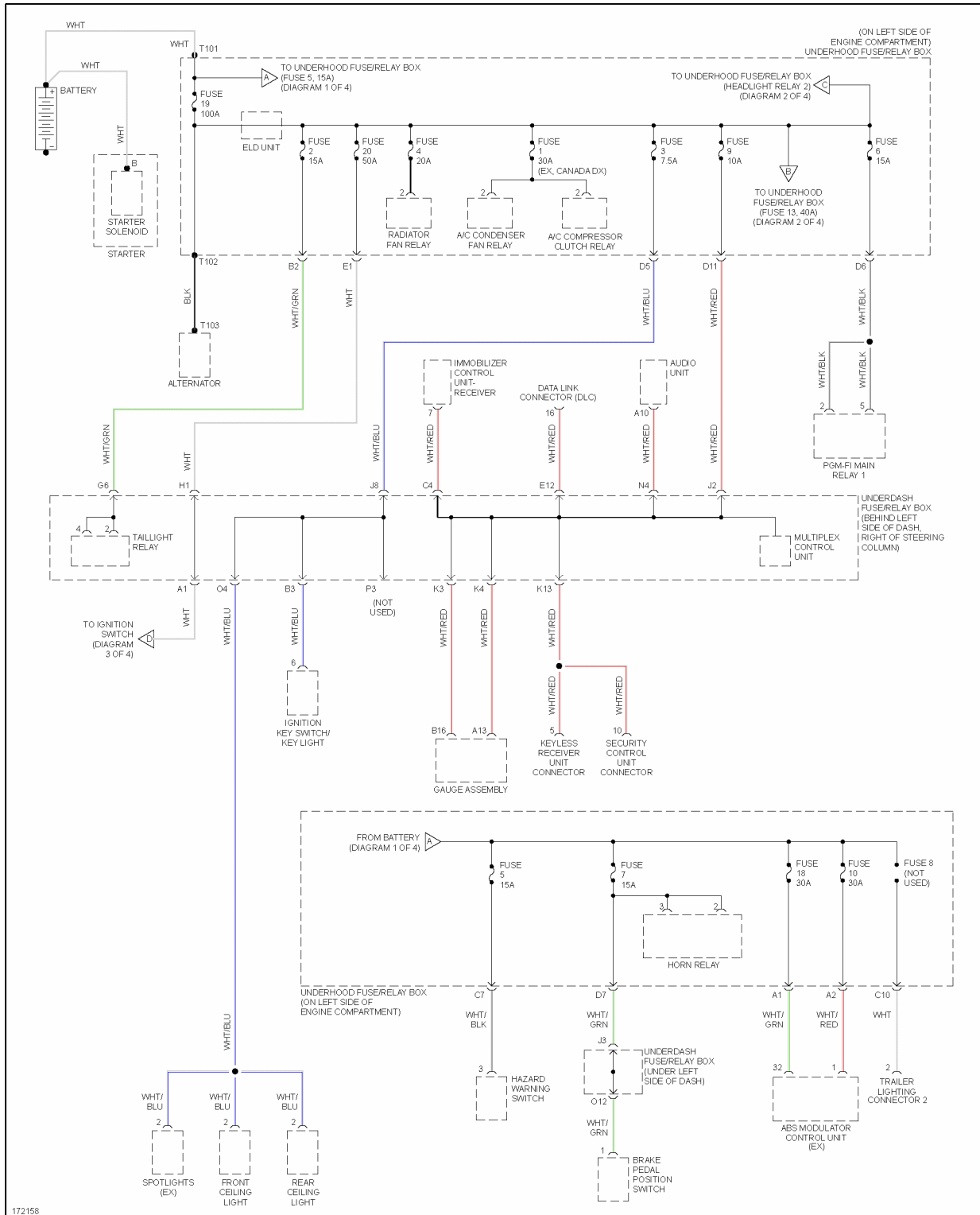

**Fig. 28: Instrument Illumination Circuit**

**POWER DISTRIBUTION**

# 2004 Honda Element DX

## 2004 SYSTEM WIRING DIAGRAMS Honda - Element



**Fig. 29: Power Distribution Circuit (1 of 4)**

# 2004 Honda Element DX

## 2004 SYSTEM WIRING DIAGRAMS Honda - Element

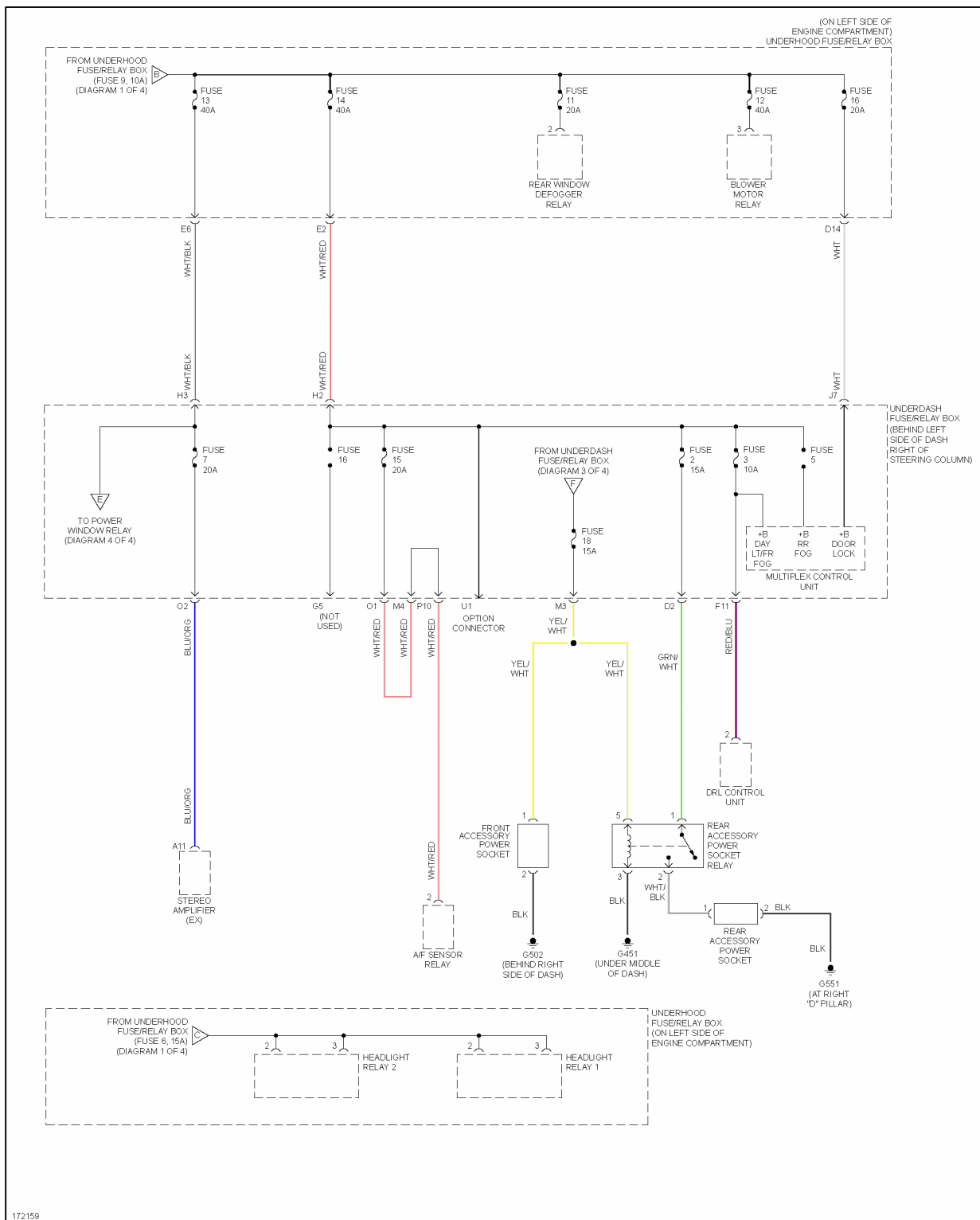
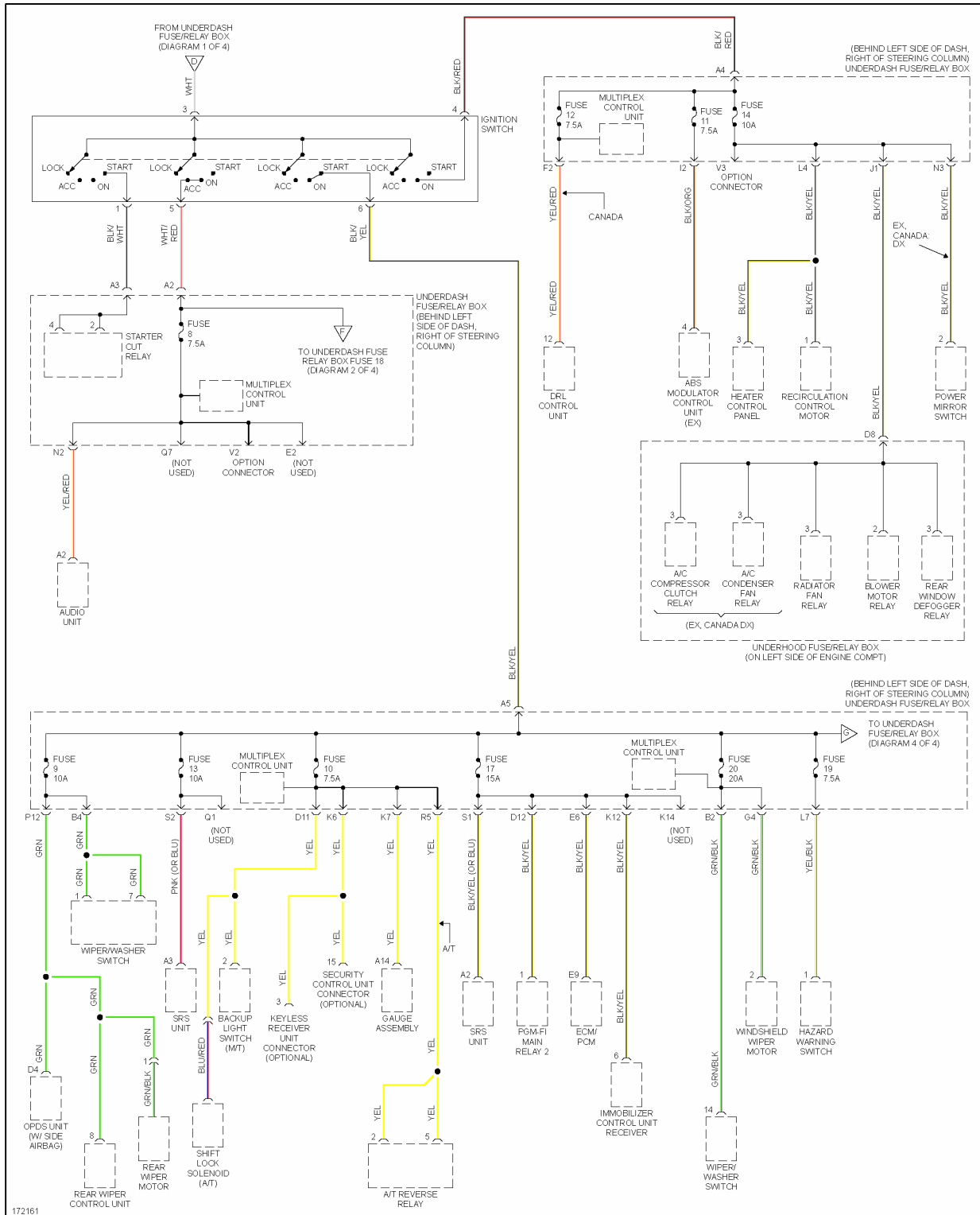



**Fig. 30: Power Distribution Circuit (2 of 4)**

# 2004 Honda Element DX

## 2004 SYSTEM WIRING DIAGRAMS Honda - Element



**Fig. 31: Power Distribution Circuit (3 of 4)**

# 2004 Honda Element DX

## 2004 SYSTEM WIRING DIAGRAMS Honda - Element

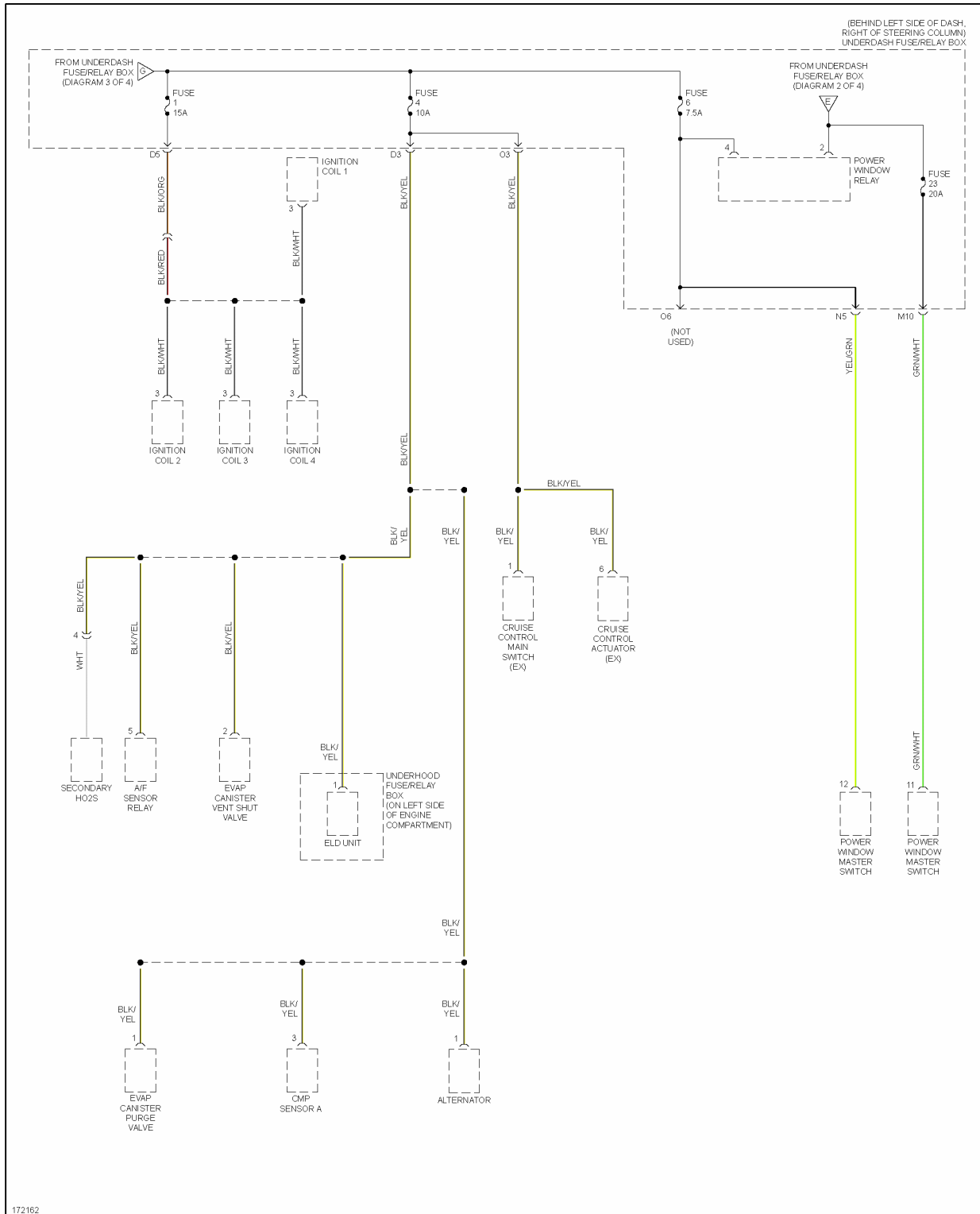
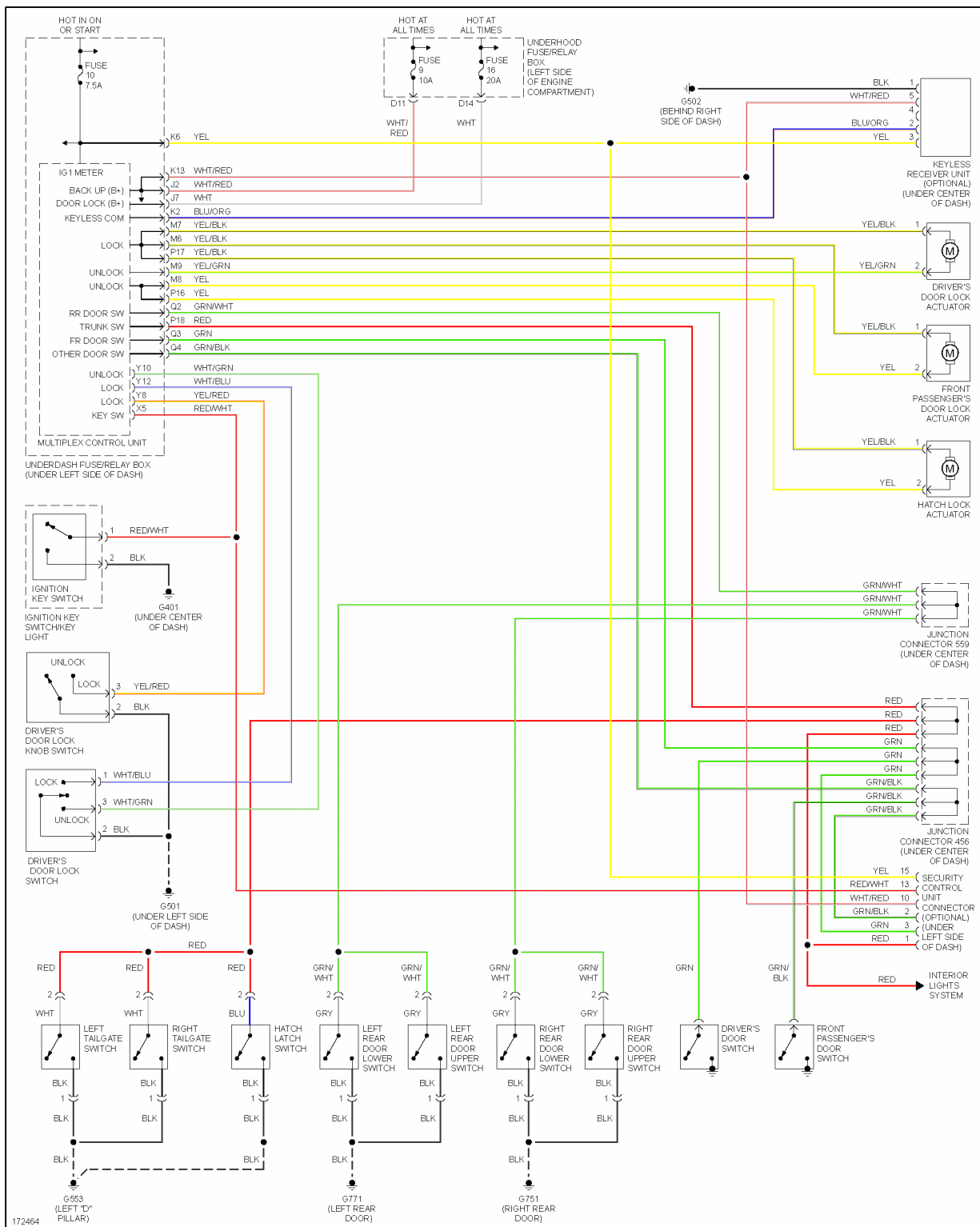

**Fig. 32: Power Distribution Circuit (4 of 4)**

**POWER DOOR LOCKS**

# 2004 Honda Element DX

## 2004 SYSTEM WIRING DIAGRAMS Honda - Element

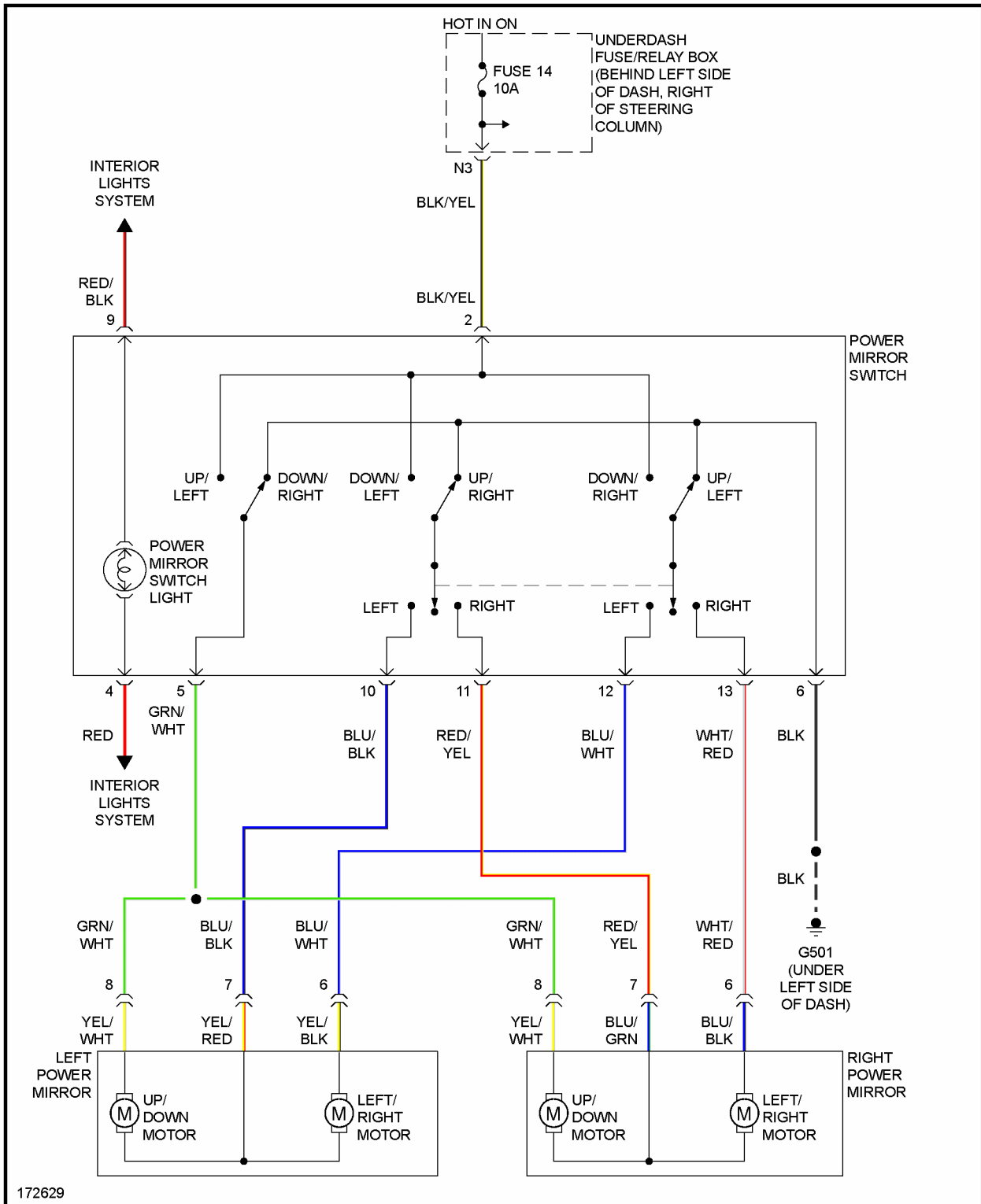

**Fig. 33: Power Door Locks Circuit**

**POWER MIRRORS**

# 2004 Honda Element DX

## 2004 SYSTEM WIRING DIAGRAMS Honda - Element



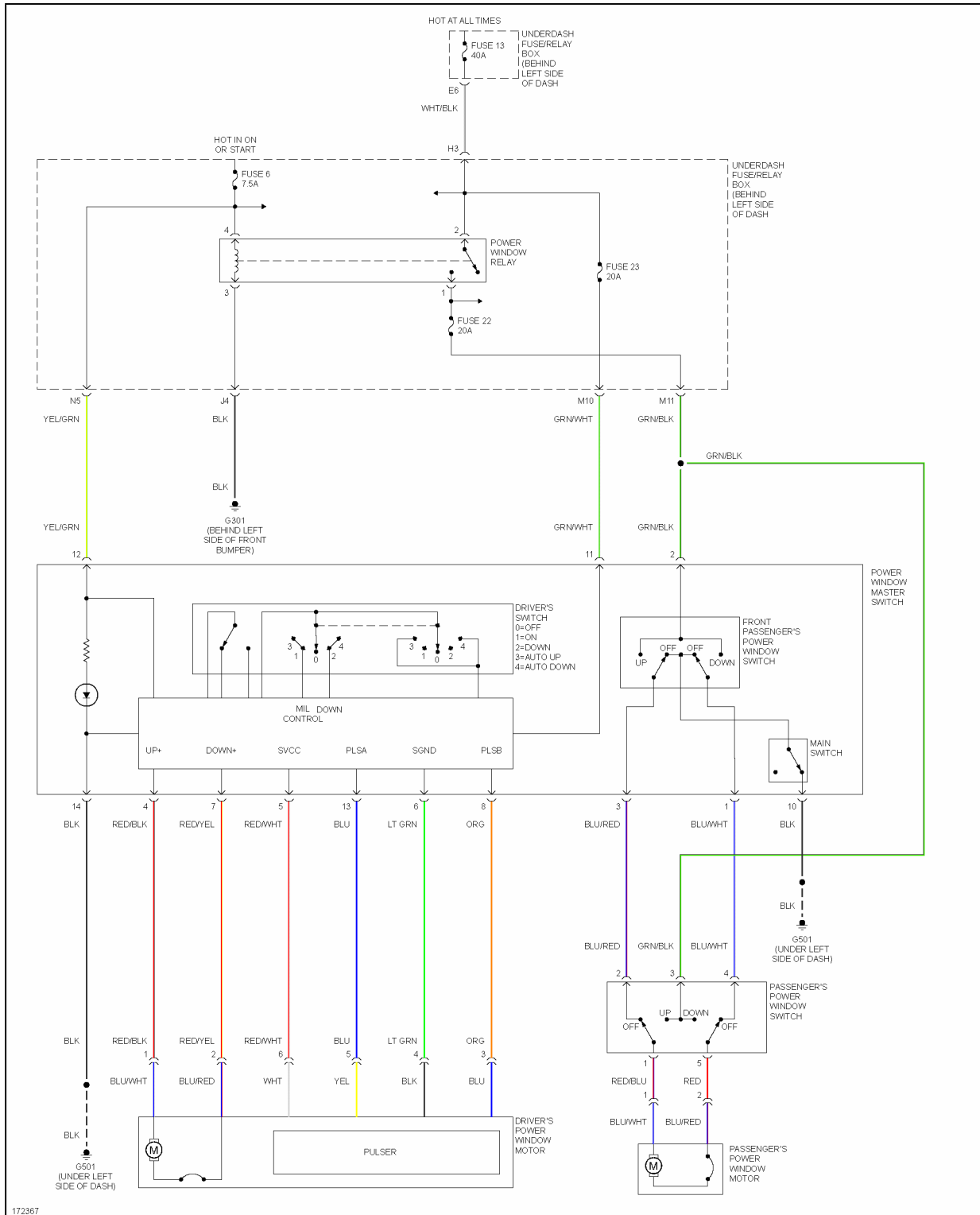

**Fig. 34: Power Mirrors Circuit**

**POWER WINDOWS**

# 2004 Honda Element DX

## 2004 SYSTEM WIRING DIAGRAMS Honda - Element

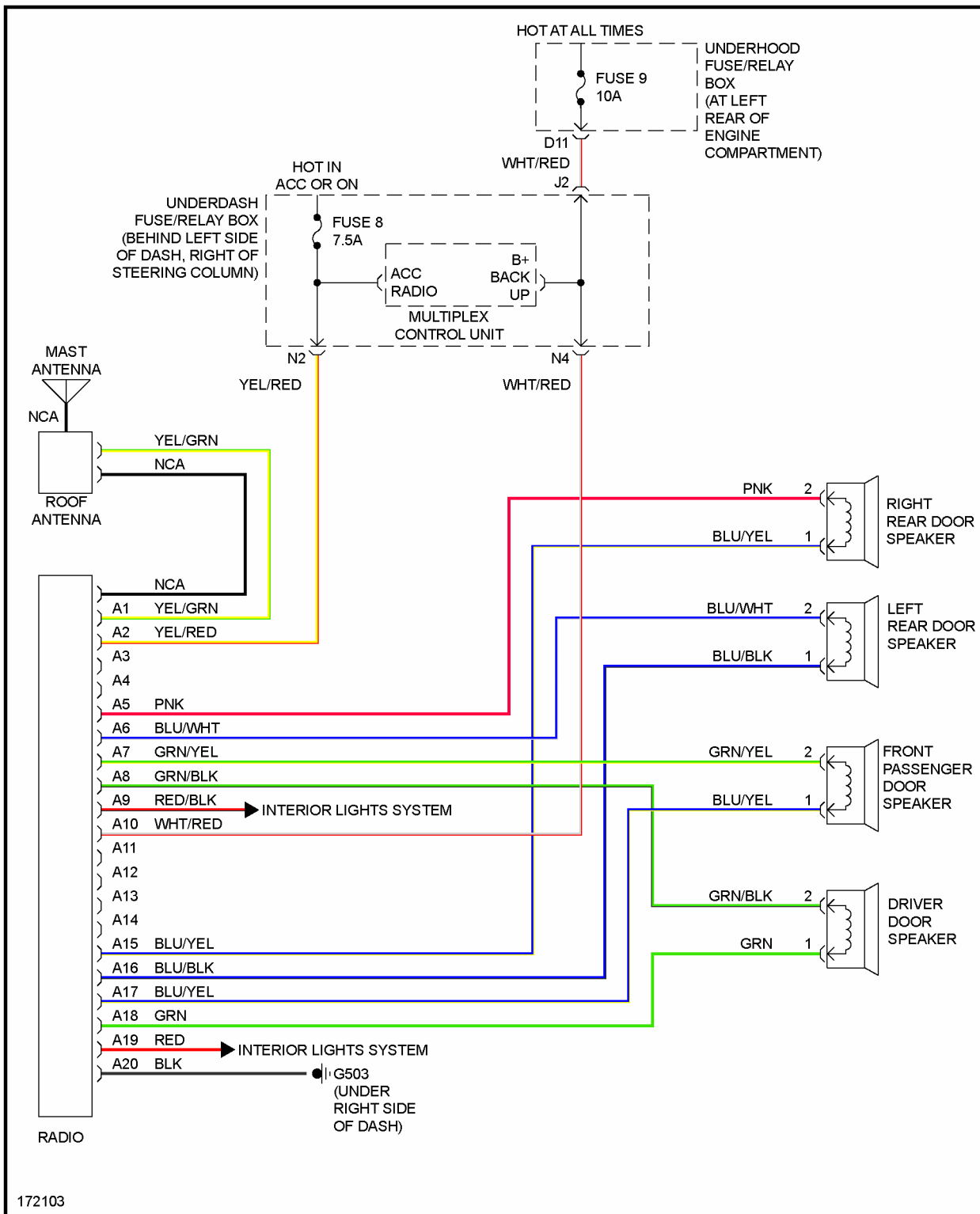

**Fig. 35: Power Windows Circuit**

**RADIO**

# 2004 Honda Element DX

## 2004 SYSTEM WIRING DIAGRAMS Honda - Element



**Fig. 36: Base Radio Circuit**

# 2004 Honda Element DX

## 2004 SYSTEM WIRING DIAGRAMS Honda - Element

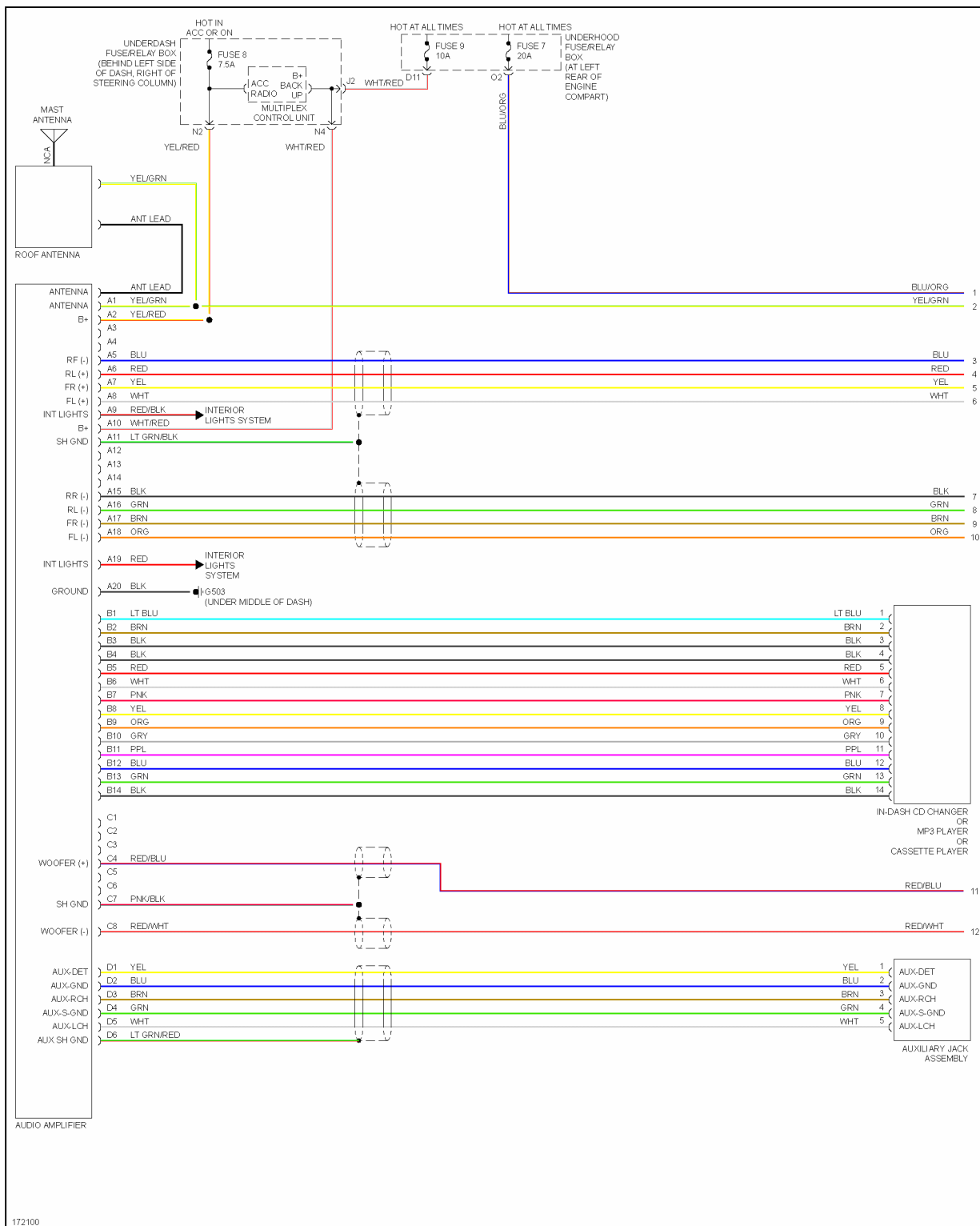

**Fig. 37: Premium Sound Radio Circuit, W/ In-dash CD Player (1 of 2)**

# 2004 Honda Element DX

## 2004 SYSTEM WIRING DIAGRAMS Honda - Element

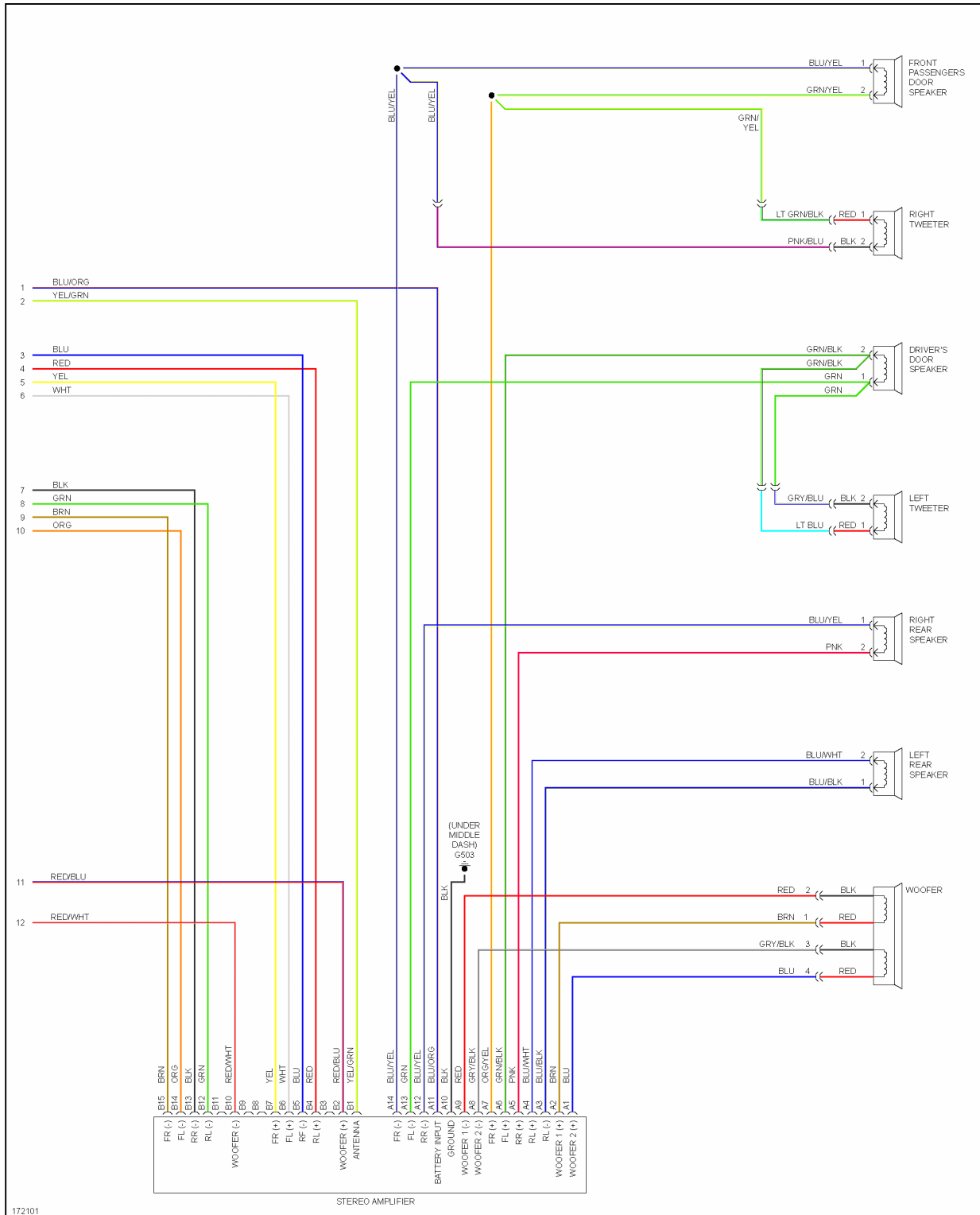
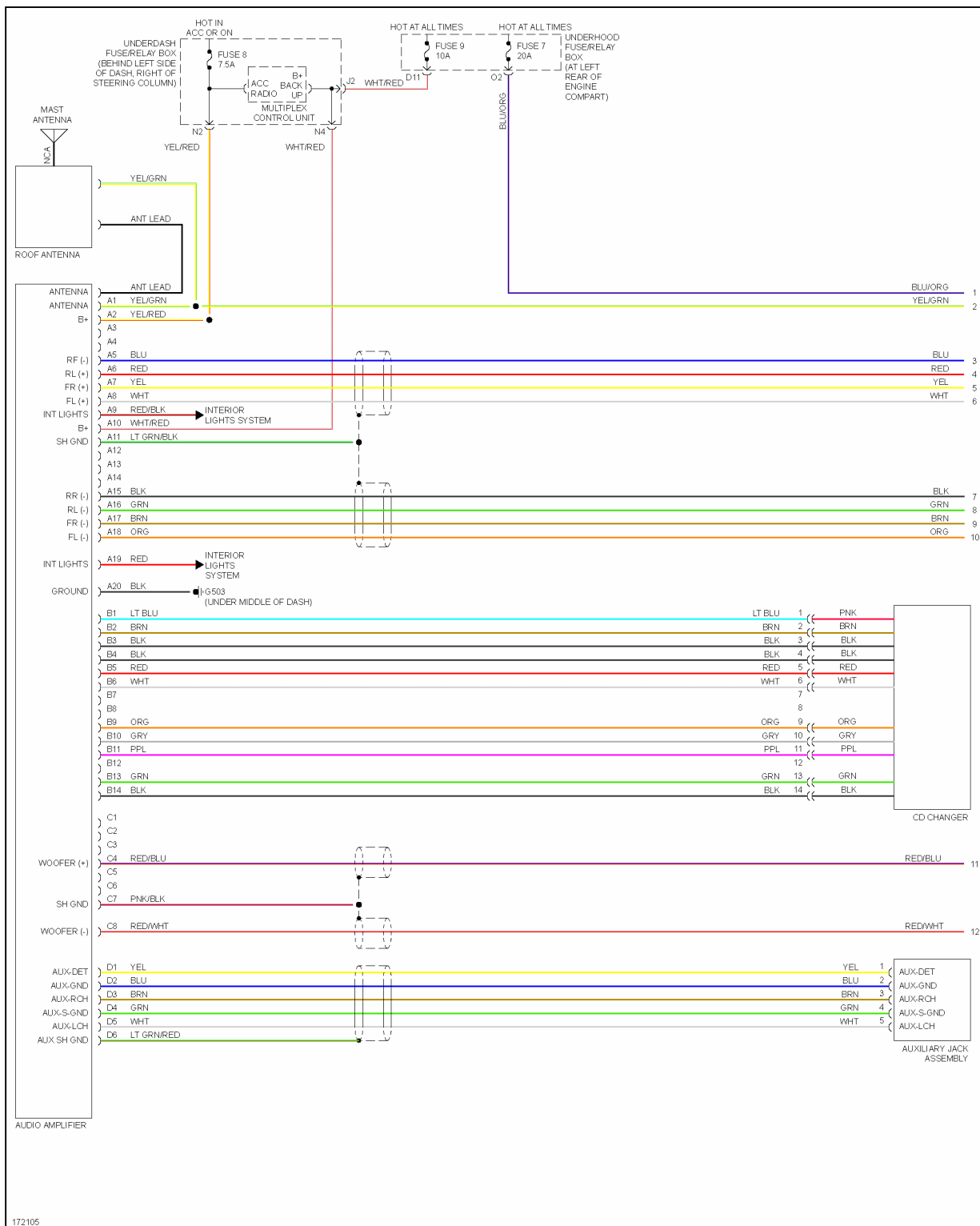



**Fig. 38: Premium Sound Radio Circuit, W/ In-dash CD Player (2 of 2)**

# 2004 Honda Element DX

## 2004 SYSTEM WIRING DIAGRAMS Honda - Element



**Fig. 39: Premium Sound Radio Circuit, W/O In-dash CD Player (1 of 2)**

# 2004 Honda Element DX

## 2004 SYSTEM WIRING DIAGRAMS Honda - Element

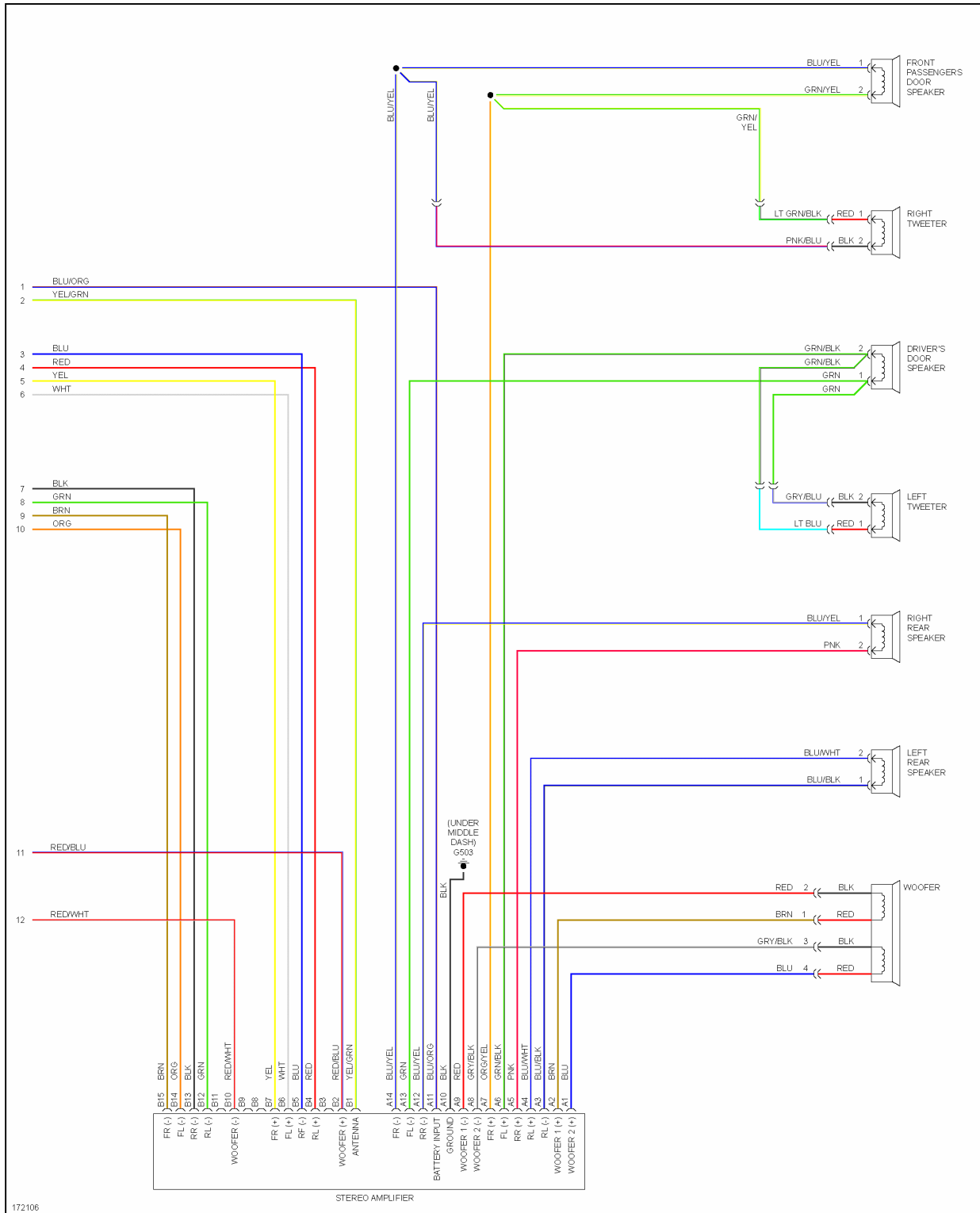
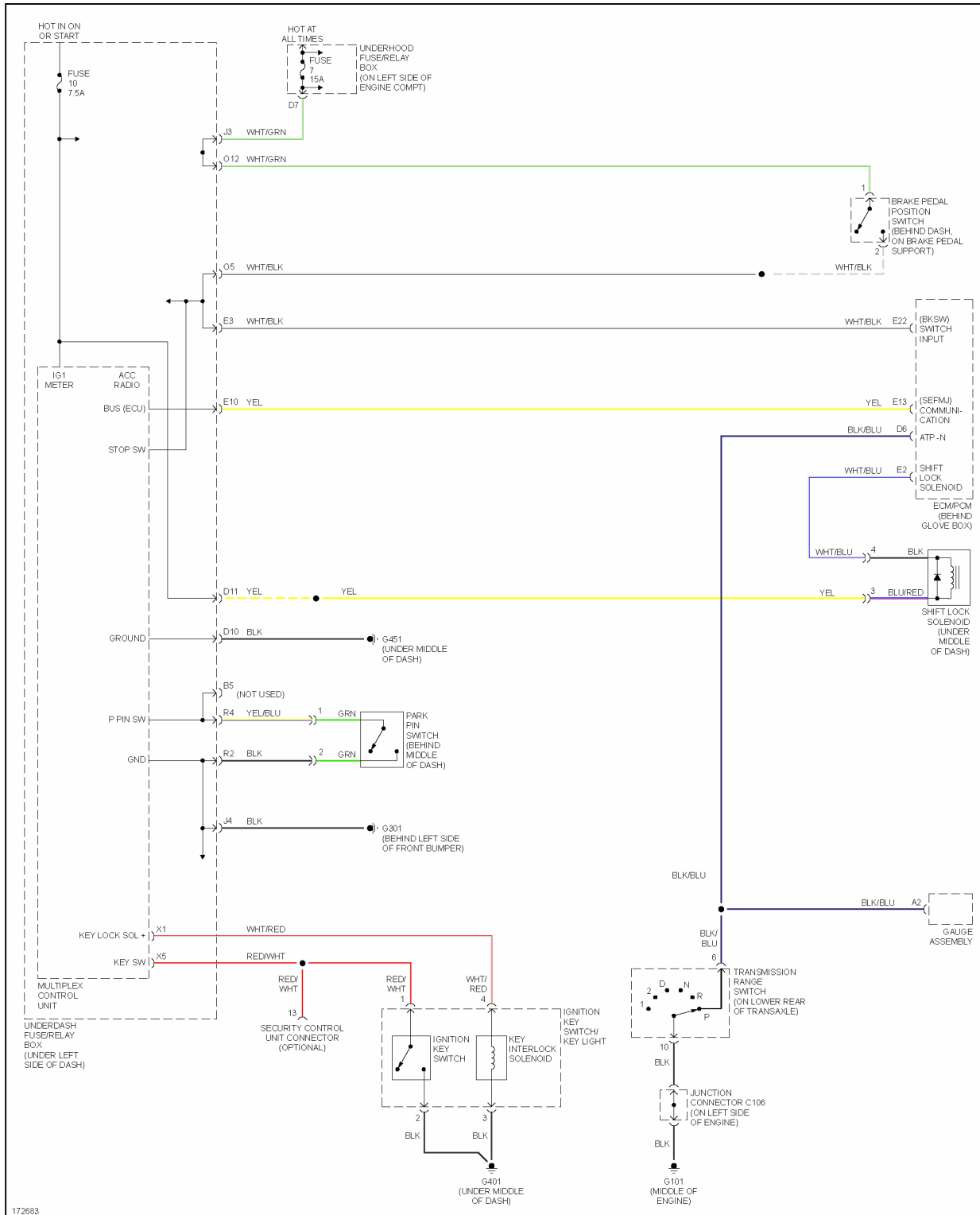

**Fig. 40: Premium Sound Radio Circuit, W/O In-dash CD Player (2 of 2)**

**SHIFT INTERLOCK**

# 2004 Honda Element DX

## 2004 SYSTEM WIRING DIAGRAMS Honda - Element

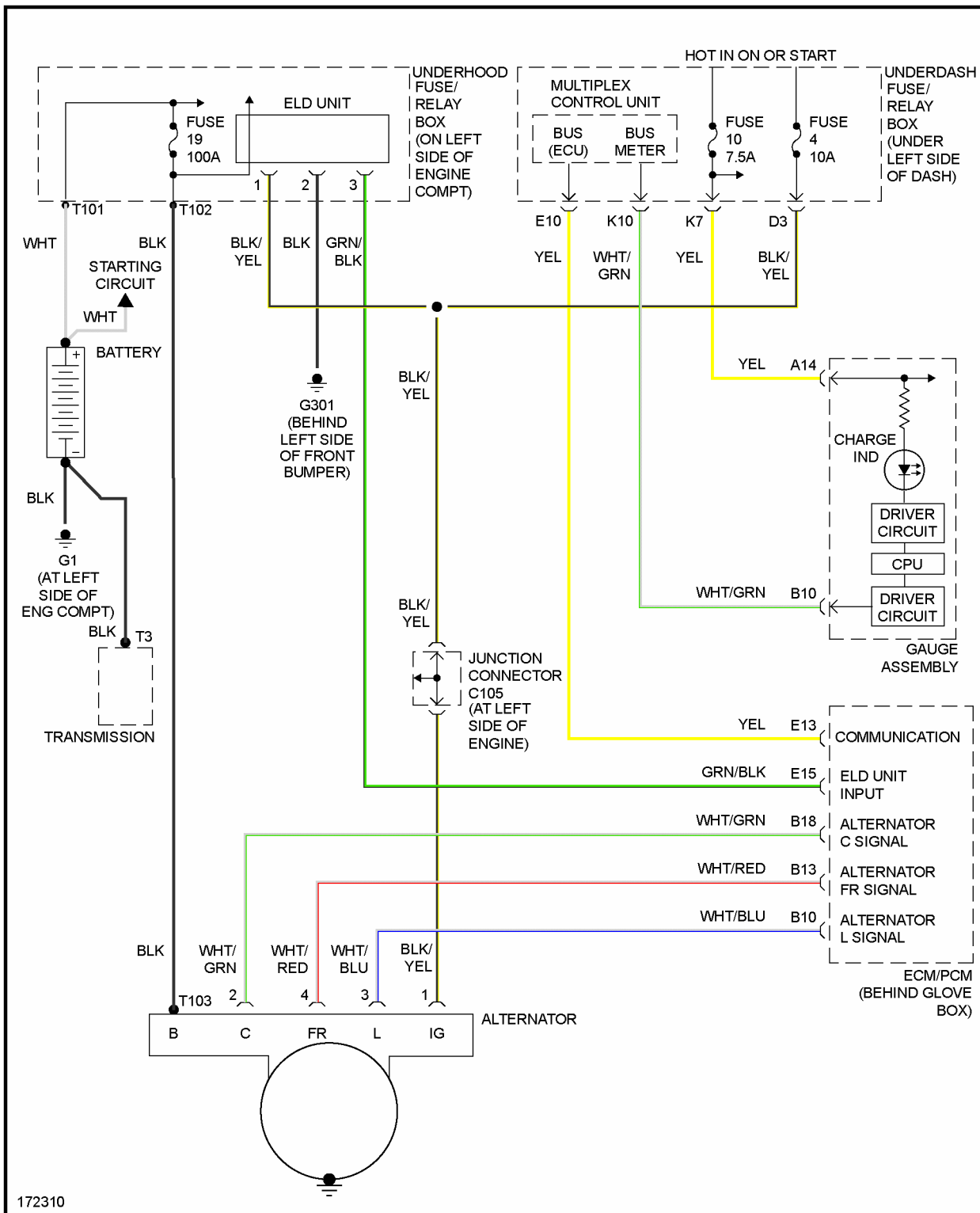

**Fig. 41: Shift Interlock Circuit**

**STARTING/CHARGING**

# 2004 Honda Element DX

## 2004 SYSTEM WIRING DIAGRAMS Honda - Element

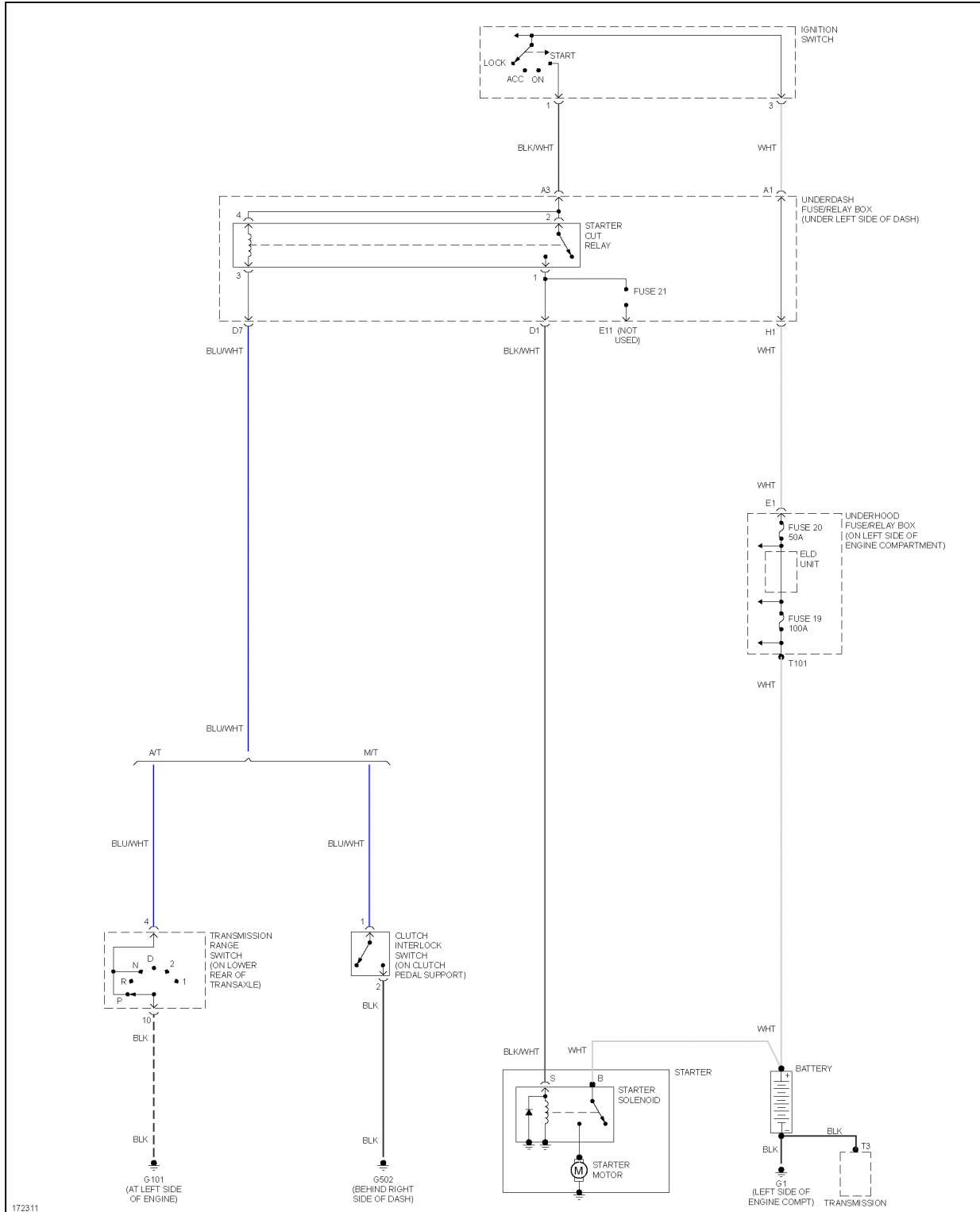



**Fig. 42: Charging Circuit**

# 2004 Honda Element DX

## 2004 SYSTEM WIRING DIAGRAMS Honda - Element

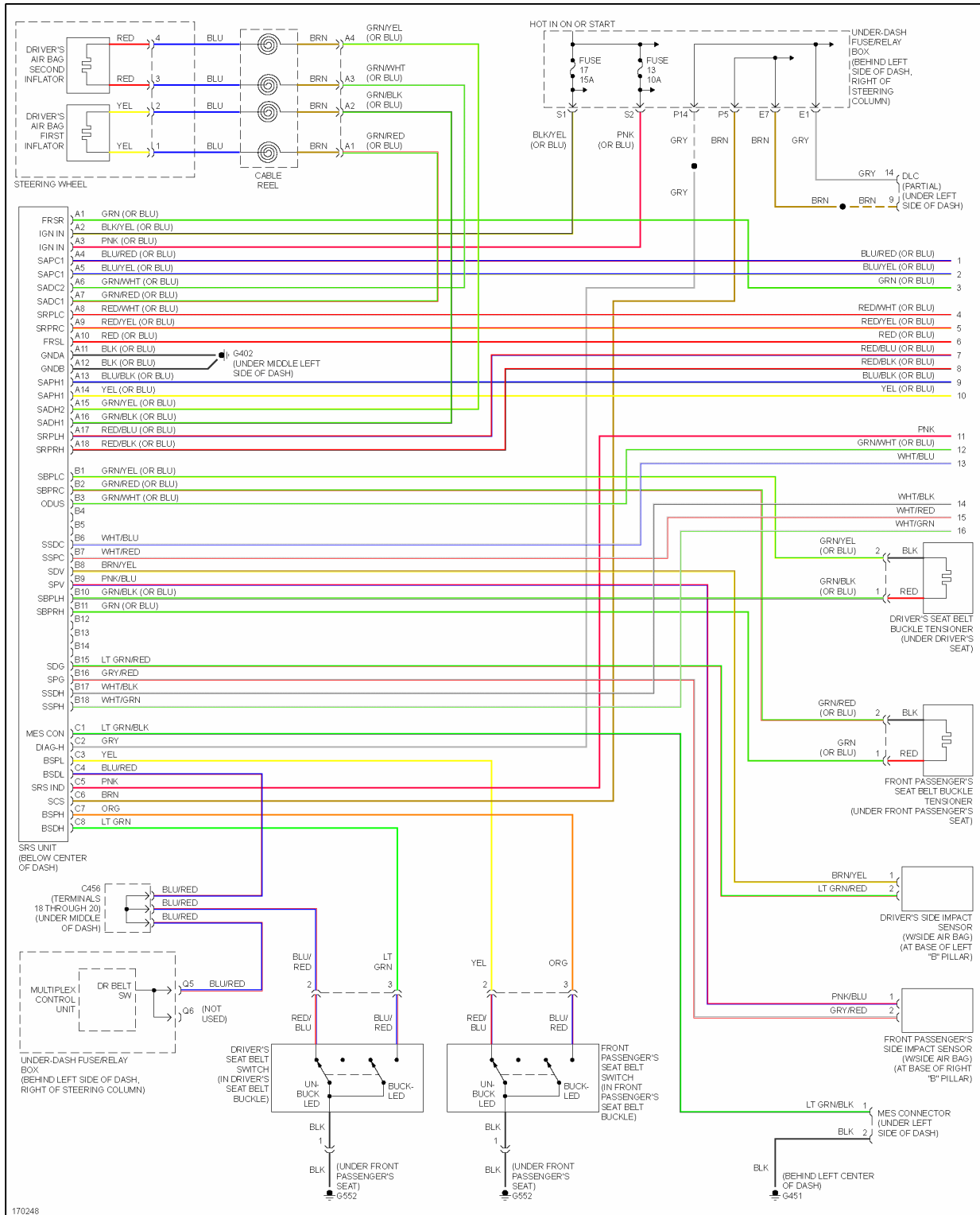

**Fig. 43: Starting Circuit**

**SUPPLEMENTAL RESTRAINTS**

# 2004 Honda Element DX

## 2004 SYSTEM WIRING DIAGRAMS Honda - Element



**Fig. 44: Supplemental Restraints Circuit (1 of 2)**

# 2004 Honda Element DX

## 2004 SYSTEM WIRING DIAGRAMS Honda - Element

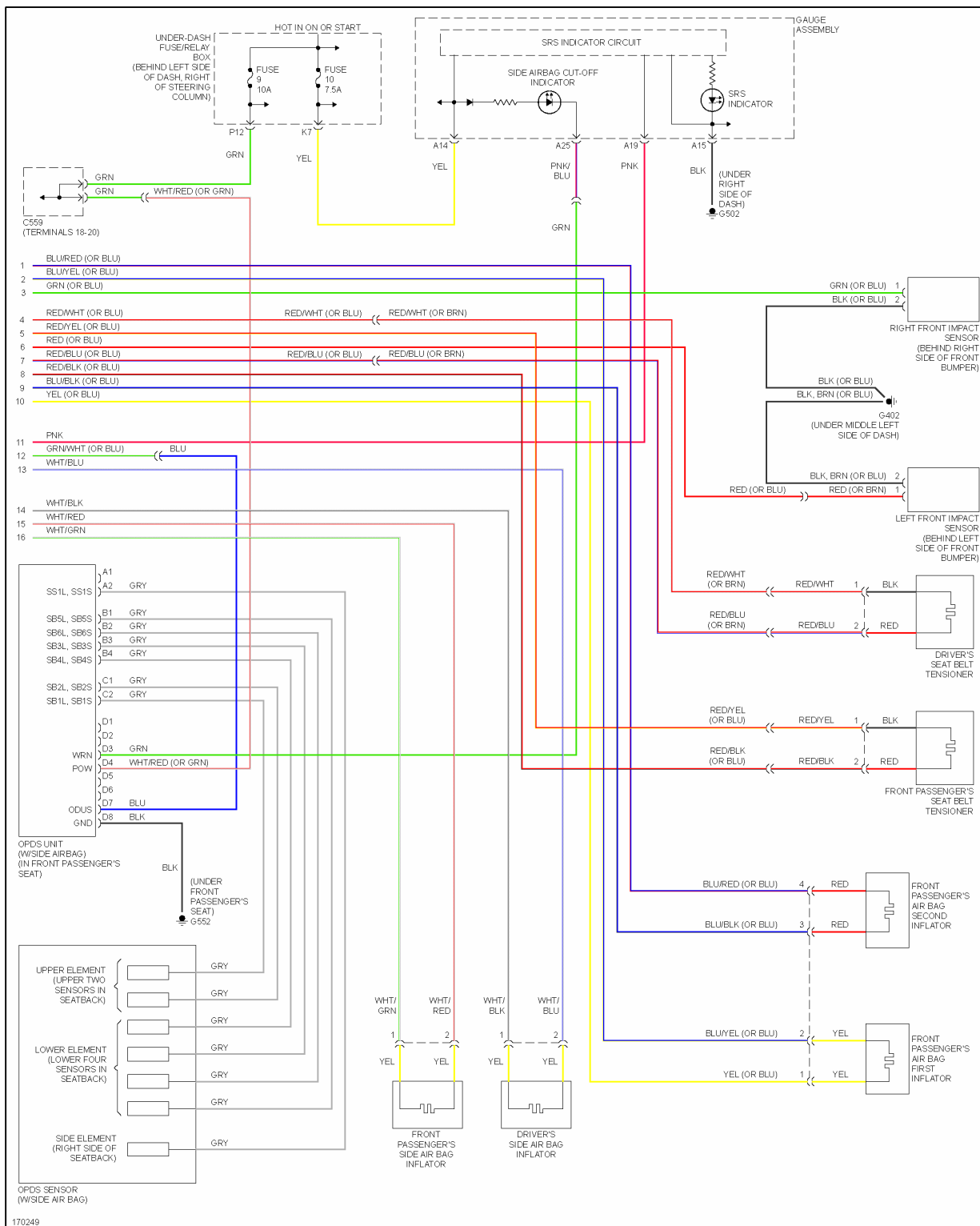
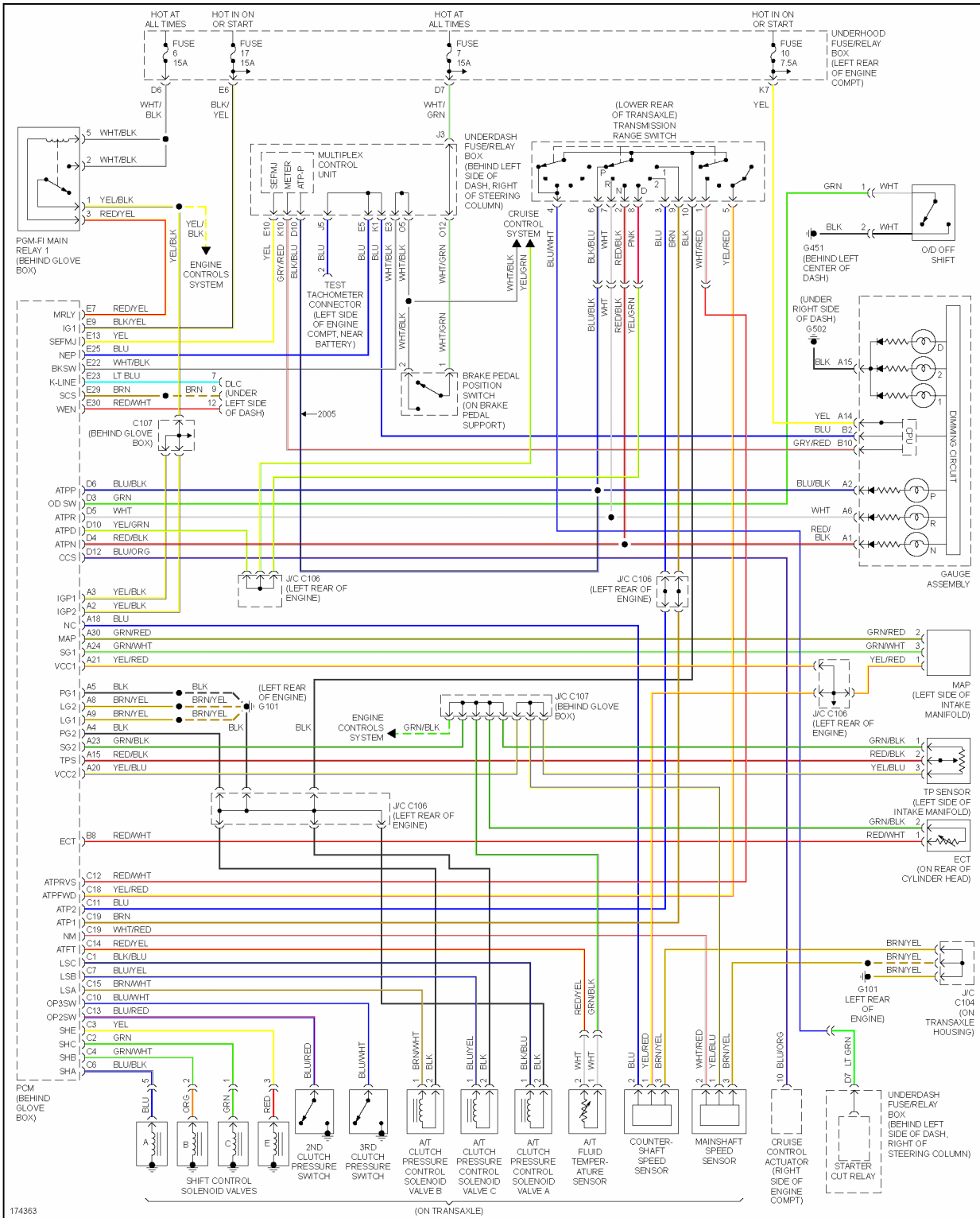

**Fig. 45: Supplemental Restraints Circuit (2 of 2)**

**TRANSMISSION**

# 2004 Honda Element DX

## 2004 SYSTEM WIRING DIAGRAMS Honda - Element



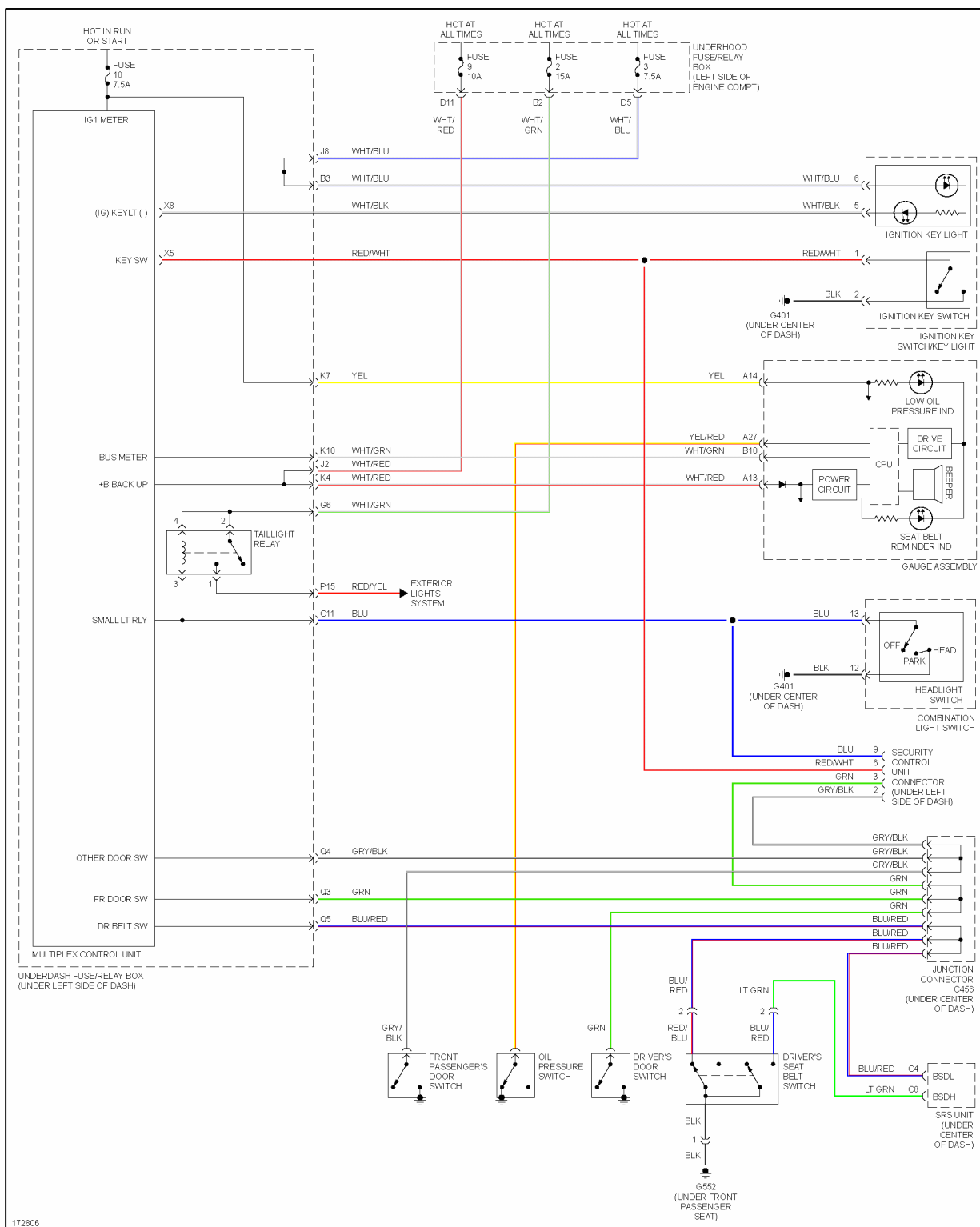

**Fig. 46: A/T Circuit**

**WARNING SYSTEMS**

# 2004 Honda Element DX

## 2004 SYSTEM WIRING DIAGRAMS Honda - Element

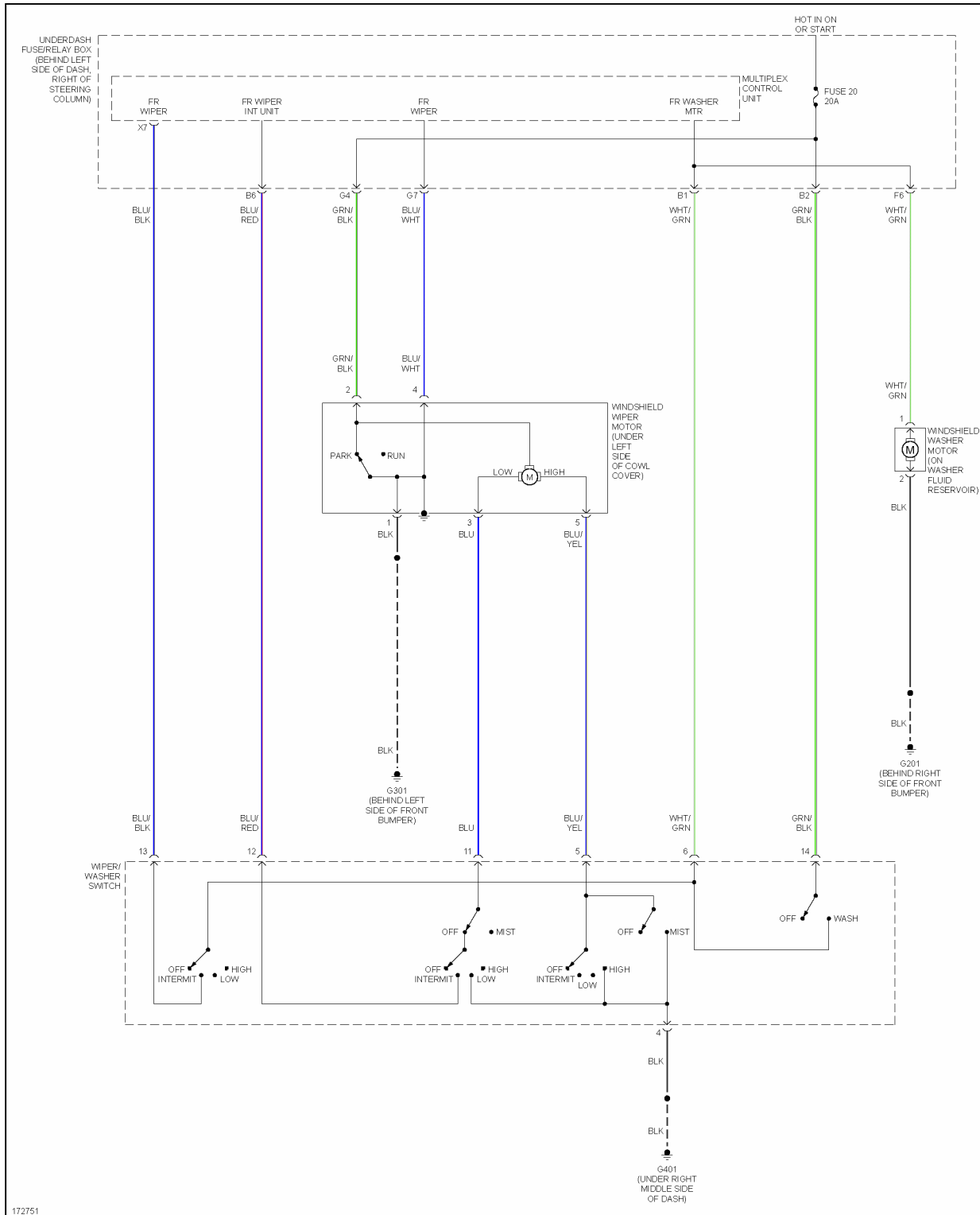

**Fig. 47: Warning Systems Circuit**

**WIPER/WASHER**

# 2004 Honda Element DX

## 2004 SYSTEM WIRING DIAGRAMS Honda - Element



**Fig. 48: Front Wiper/Washer Circuit**

# 2004 Honda Element DX

## 2004 SYSTEM WIRING DIAGRAMS Honda - Element

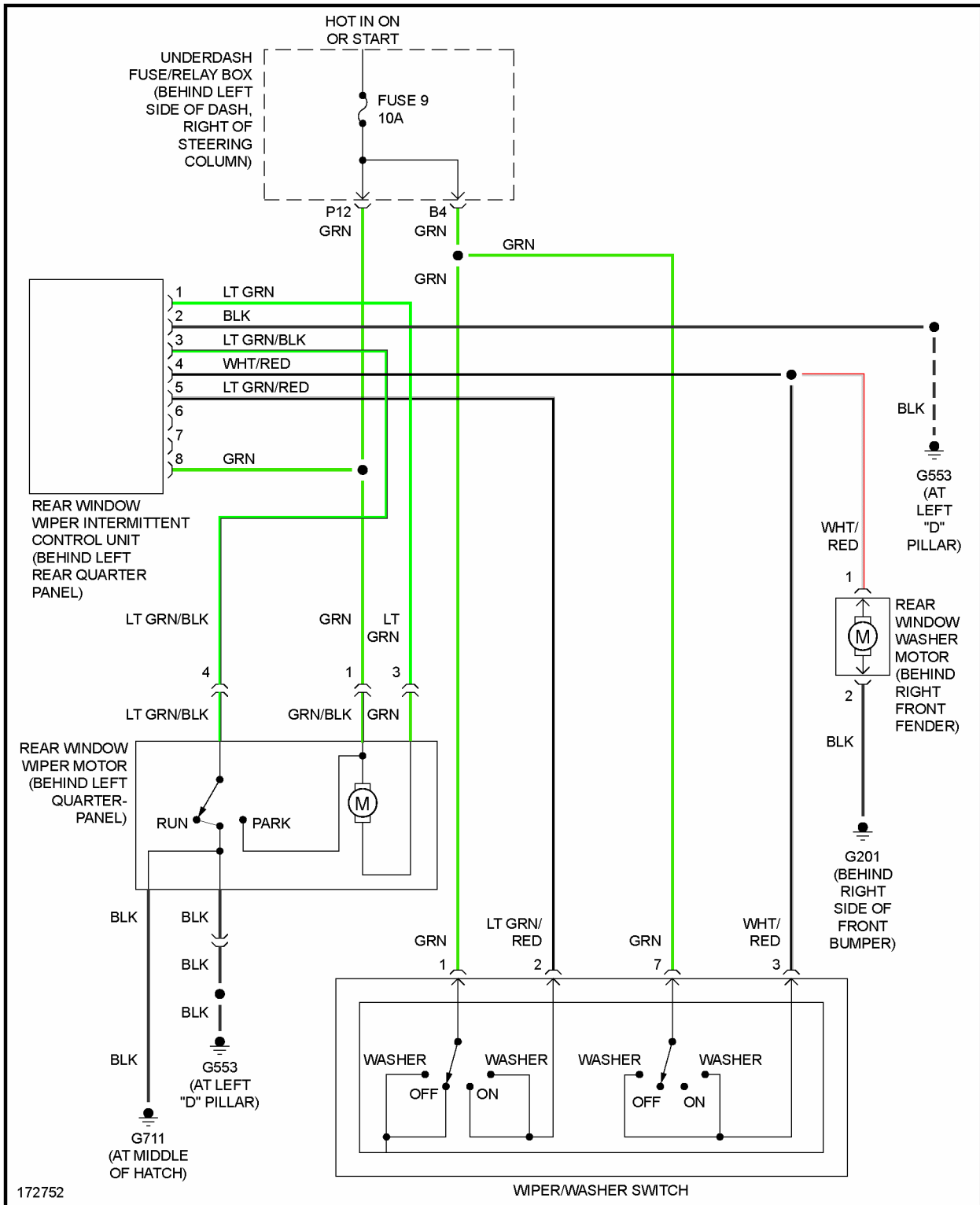

**Fig. 49: Rear Wiper/Washer Circuit**

