

# Hybrid System and Shift Control System

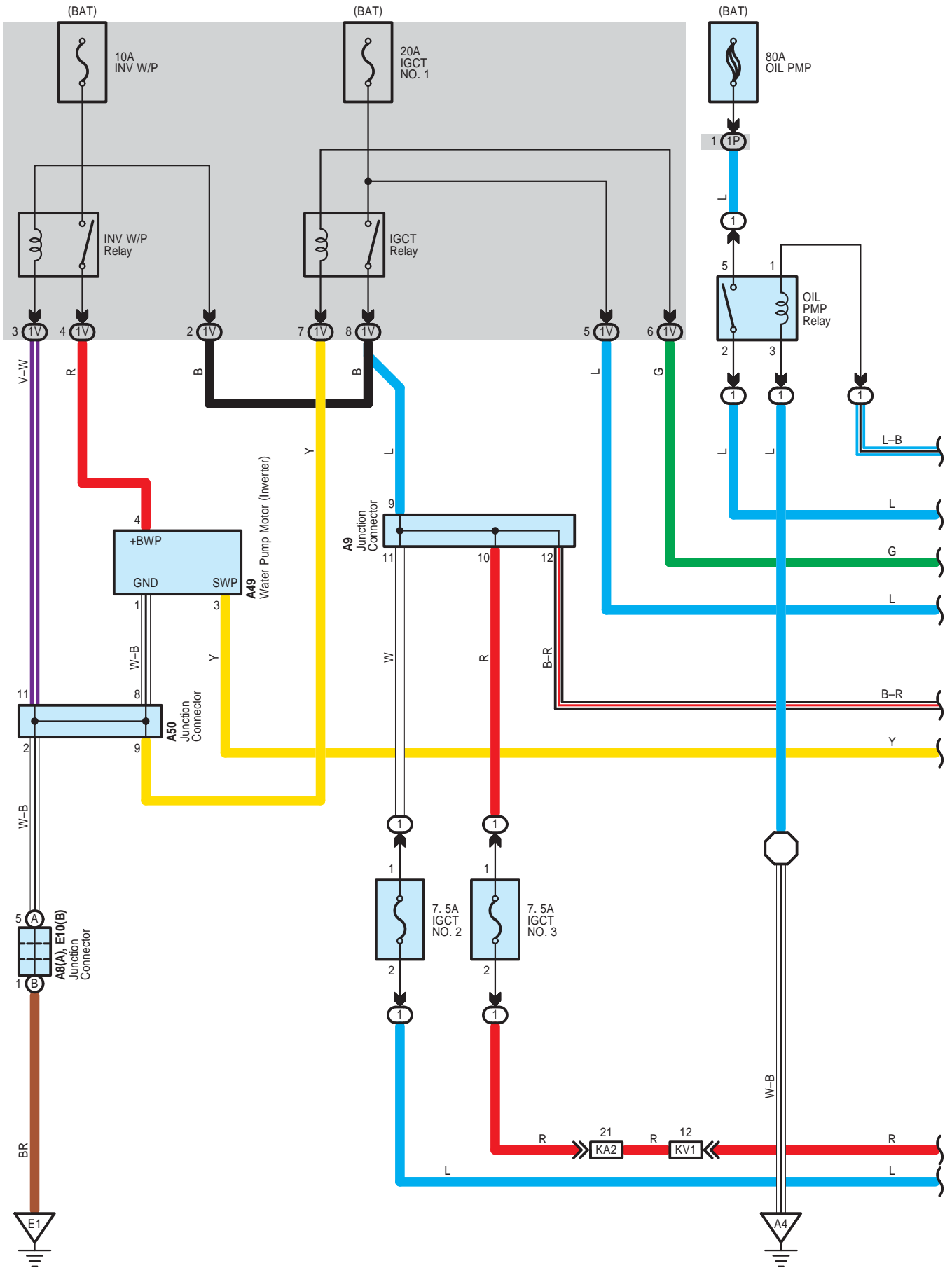

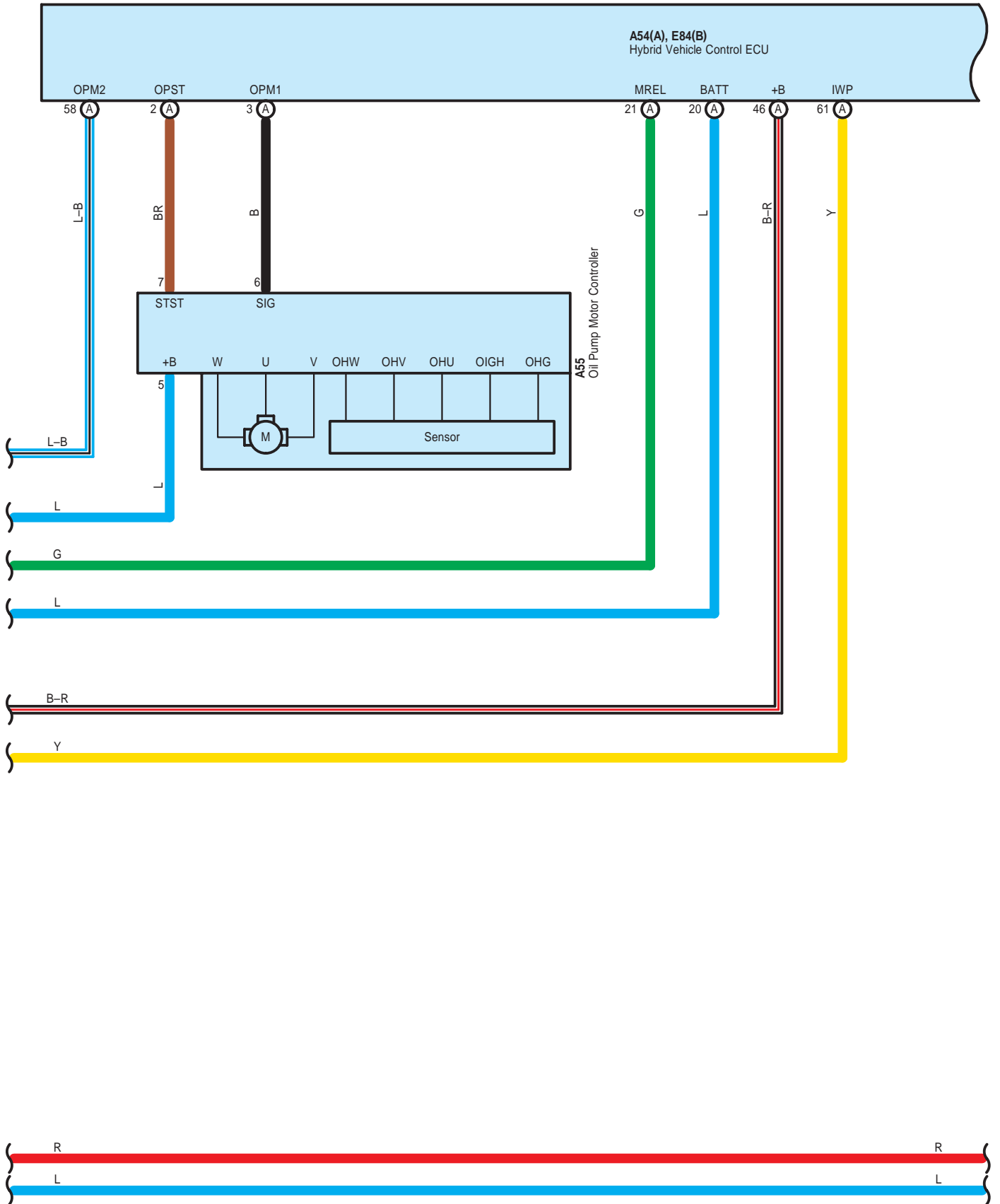

# Hybrid System and Shift Control System

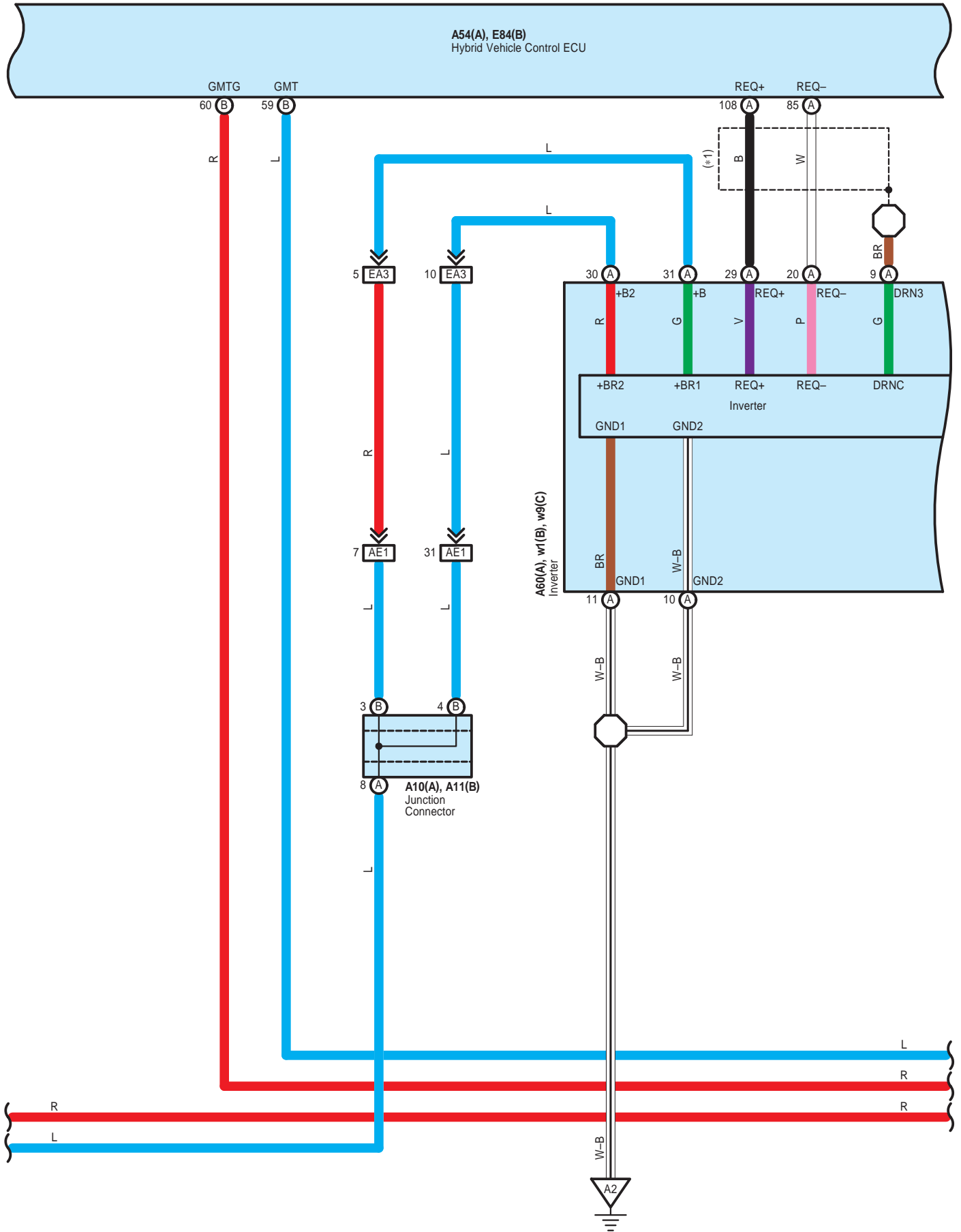

\* 1 : Shielded

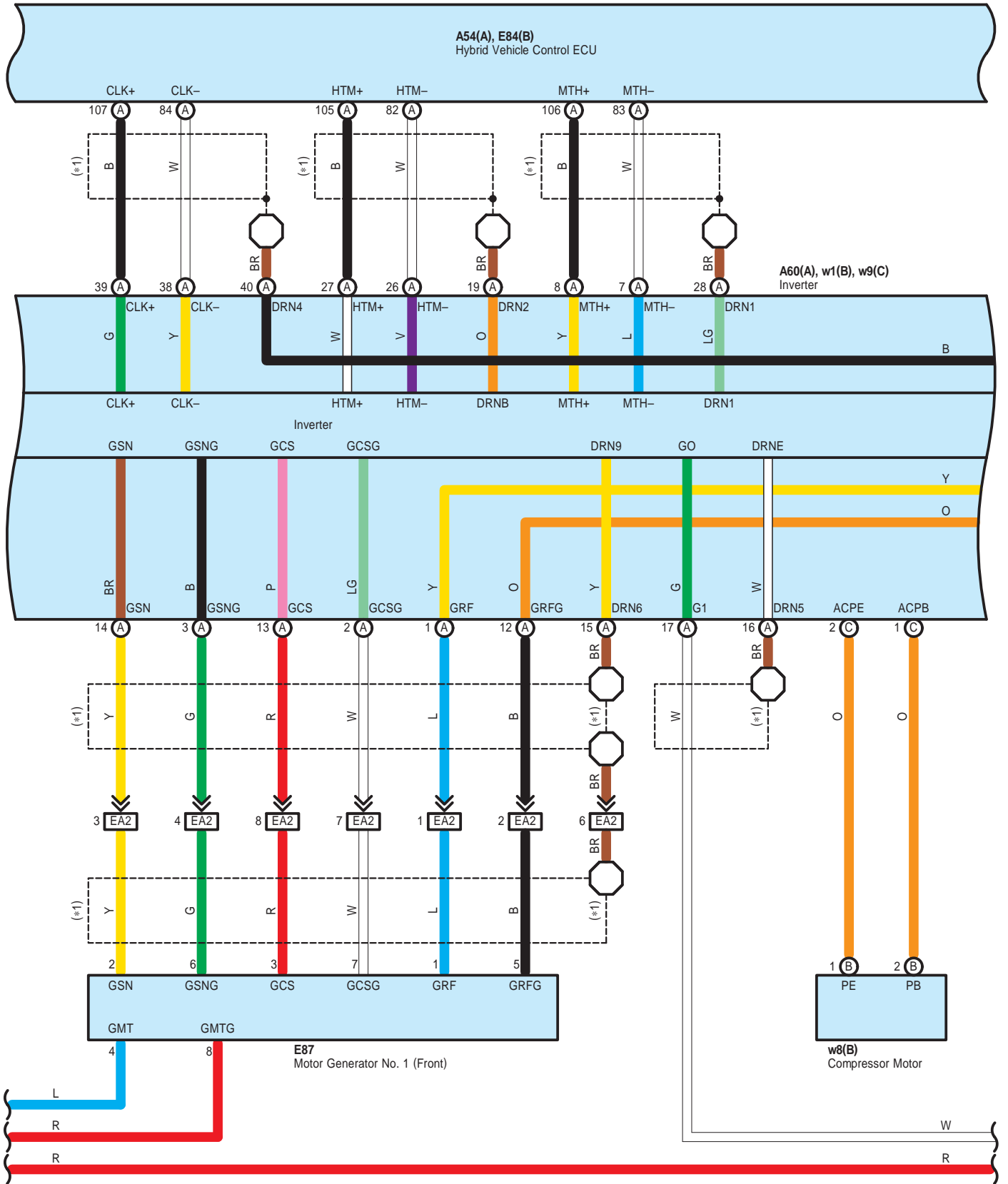

# Hybrid System and Shift Control System

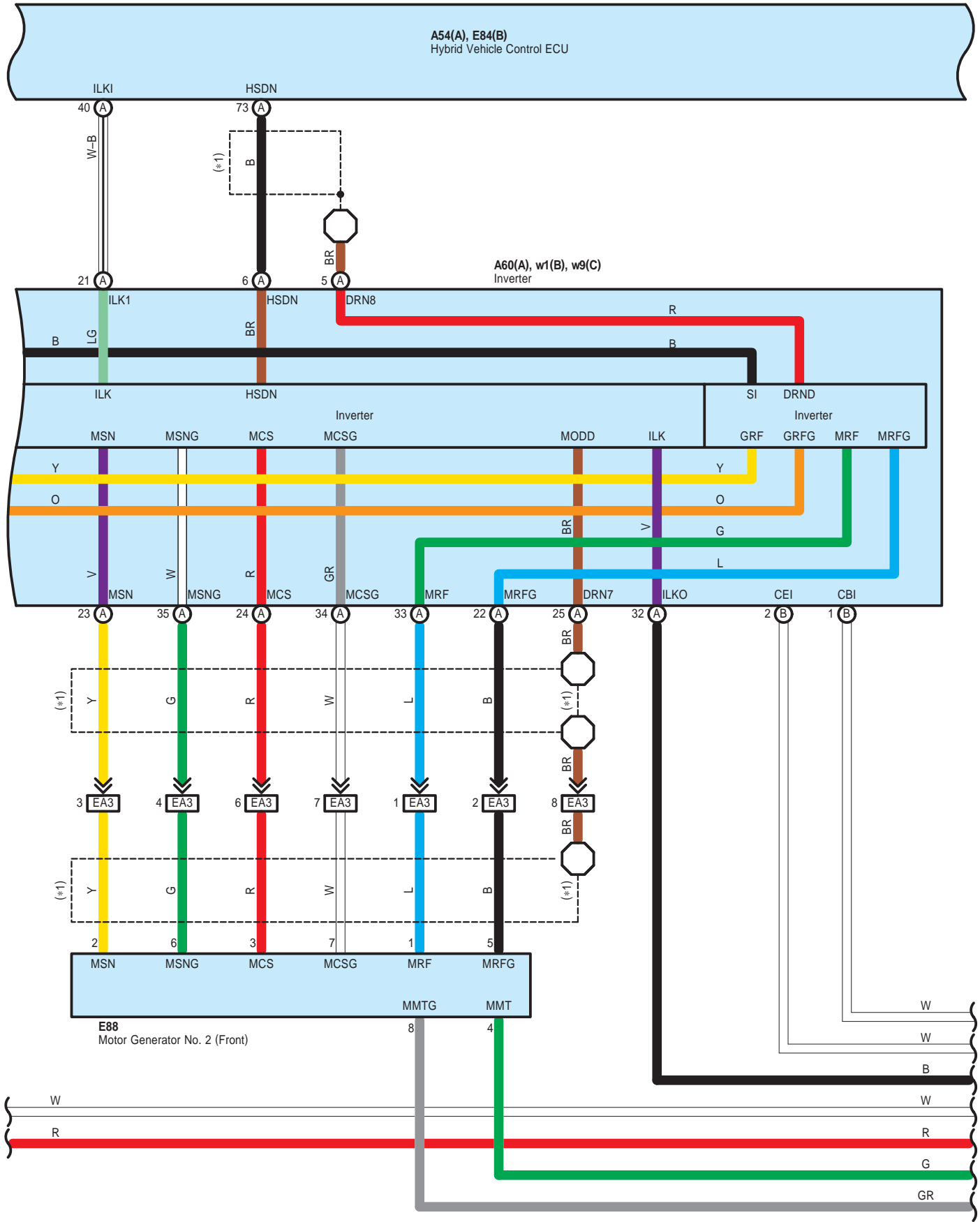

\* 1 : Shielded

**A54(A), E84(B)**  
Hybrid Vehicle Control ECU

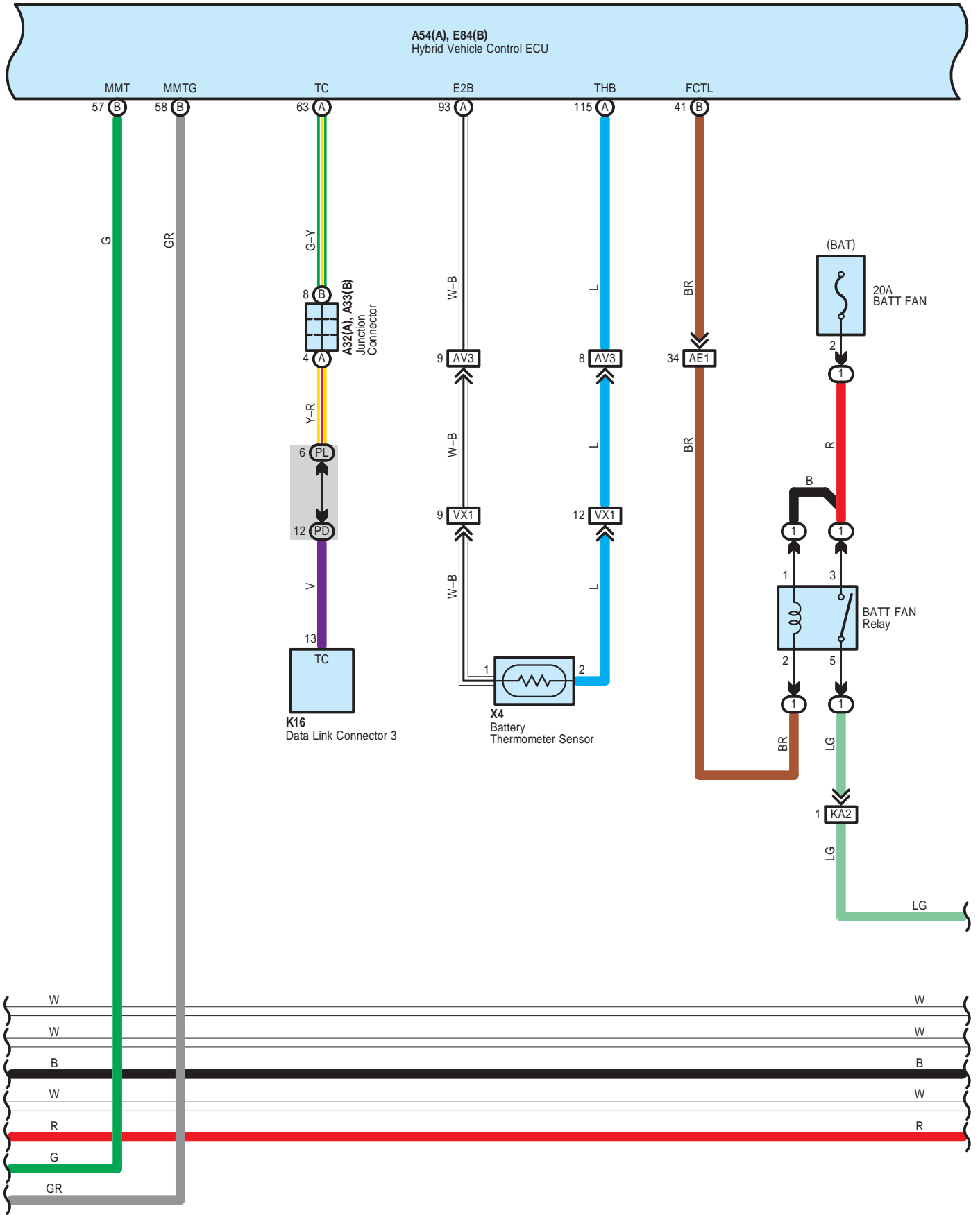

# Hybrid System and Shift Control System

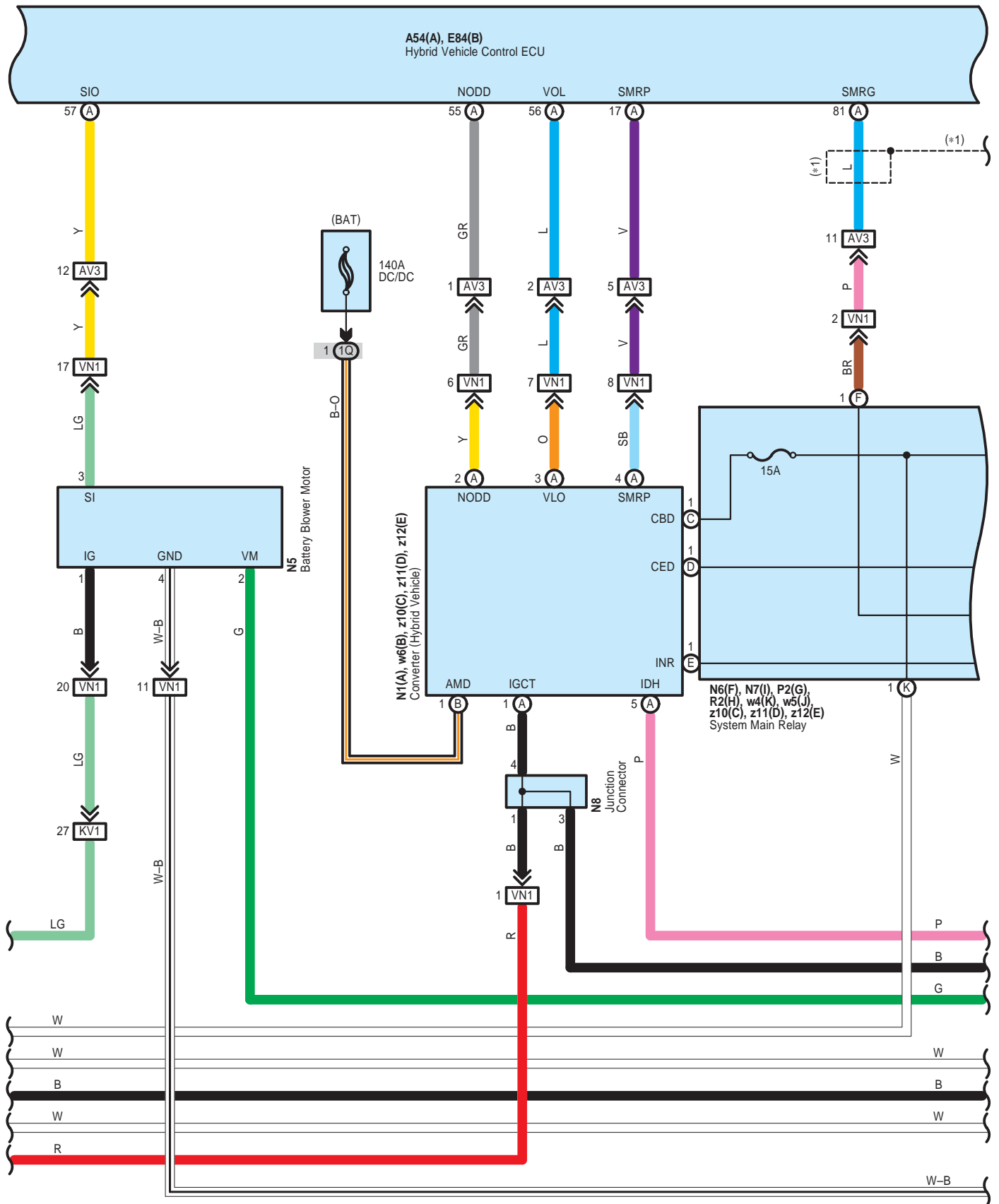

\* 1 : Shielded

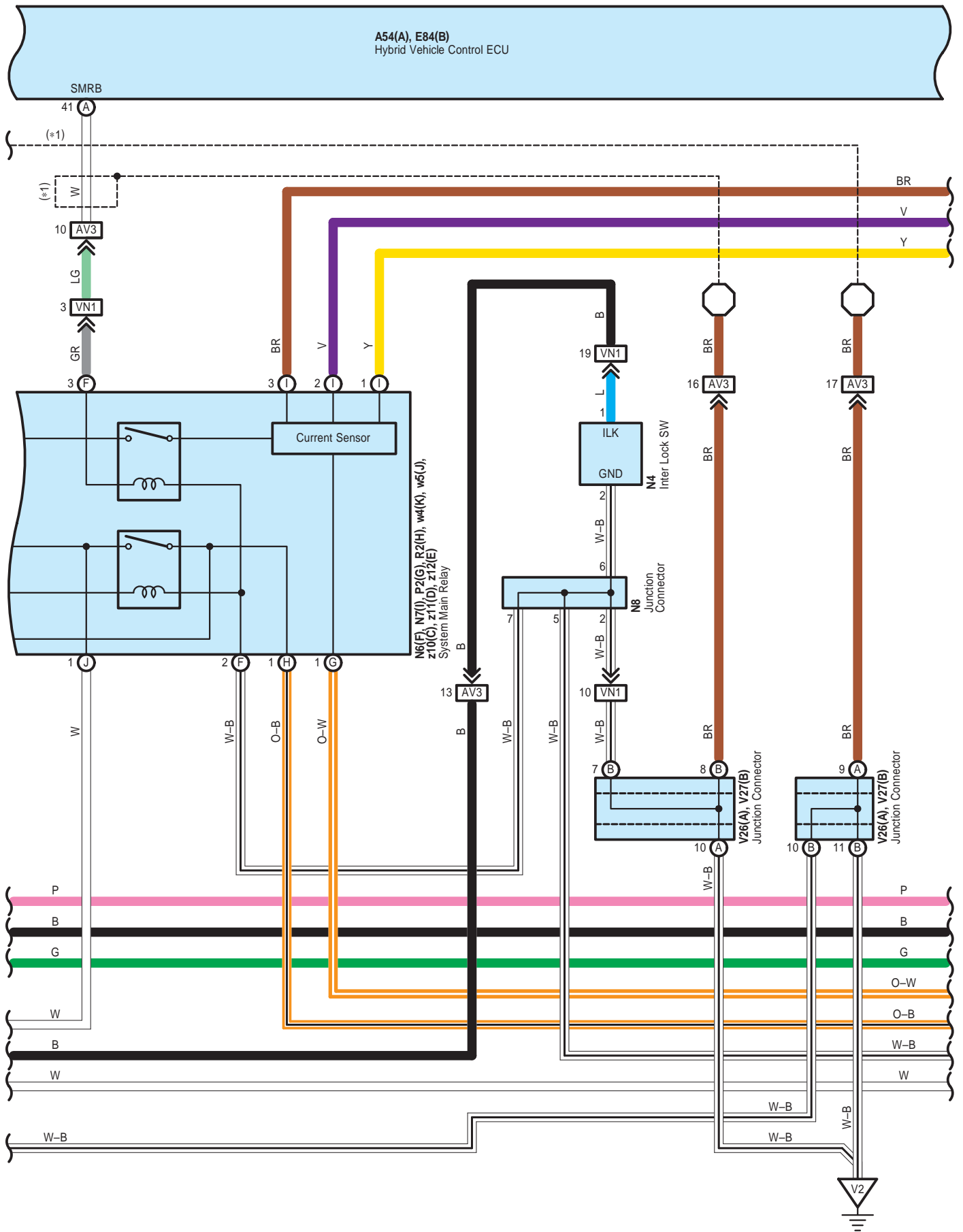



# Hybrid System and Shift Control System

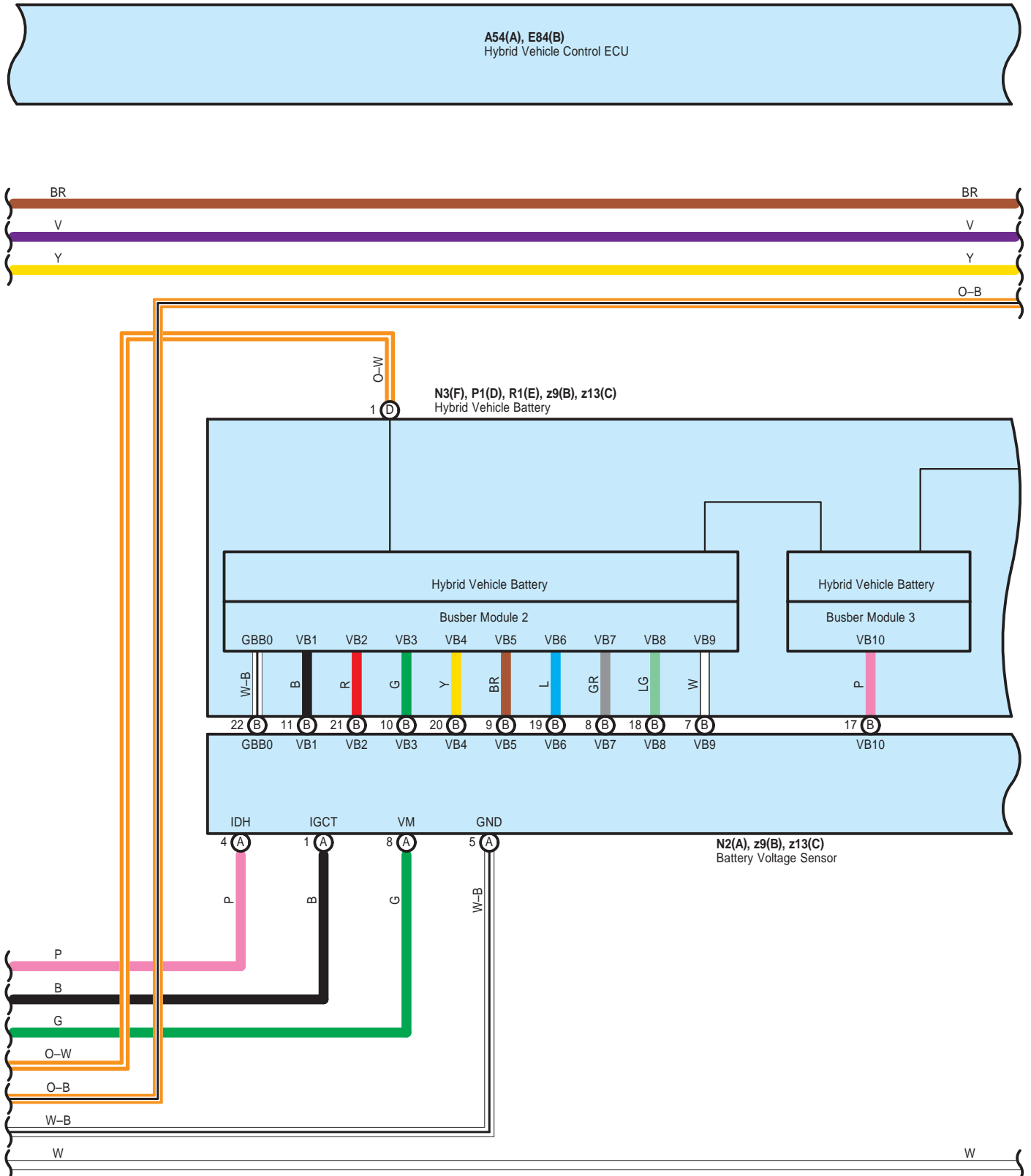

A54(A), E84(B)  
Hybrid Vehicle Control ECU

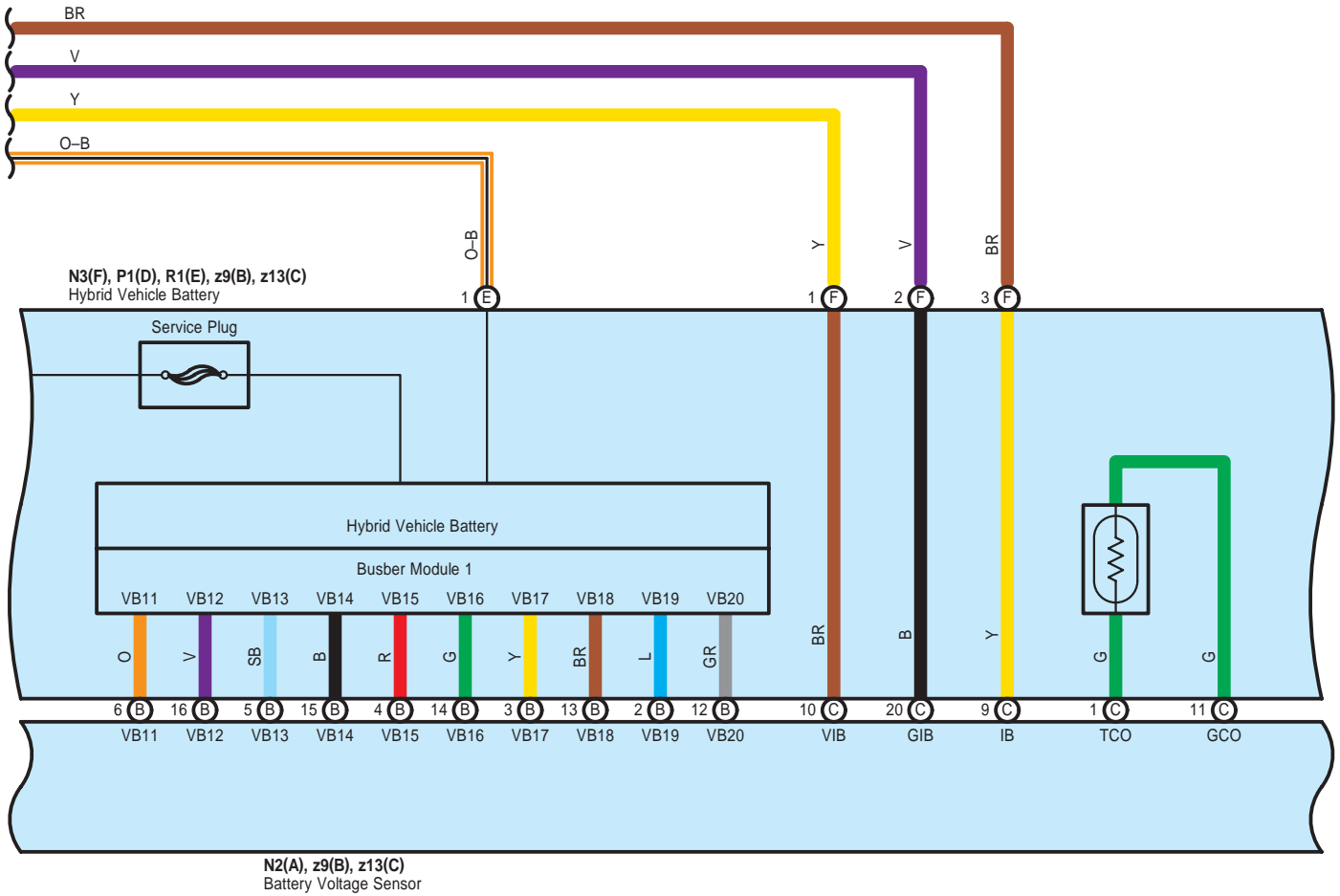

W

W

# Hybrid System and Shift Control System

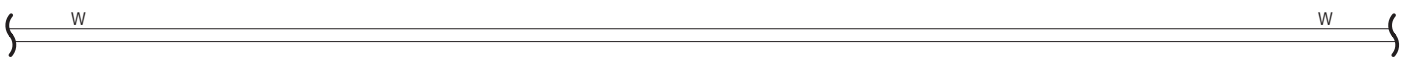
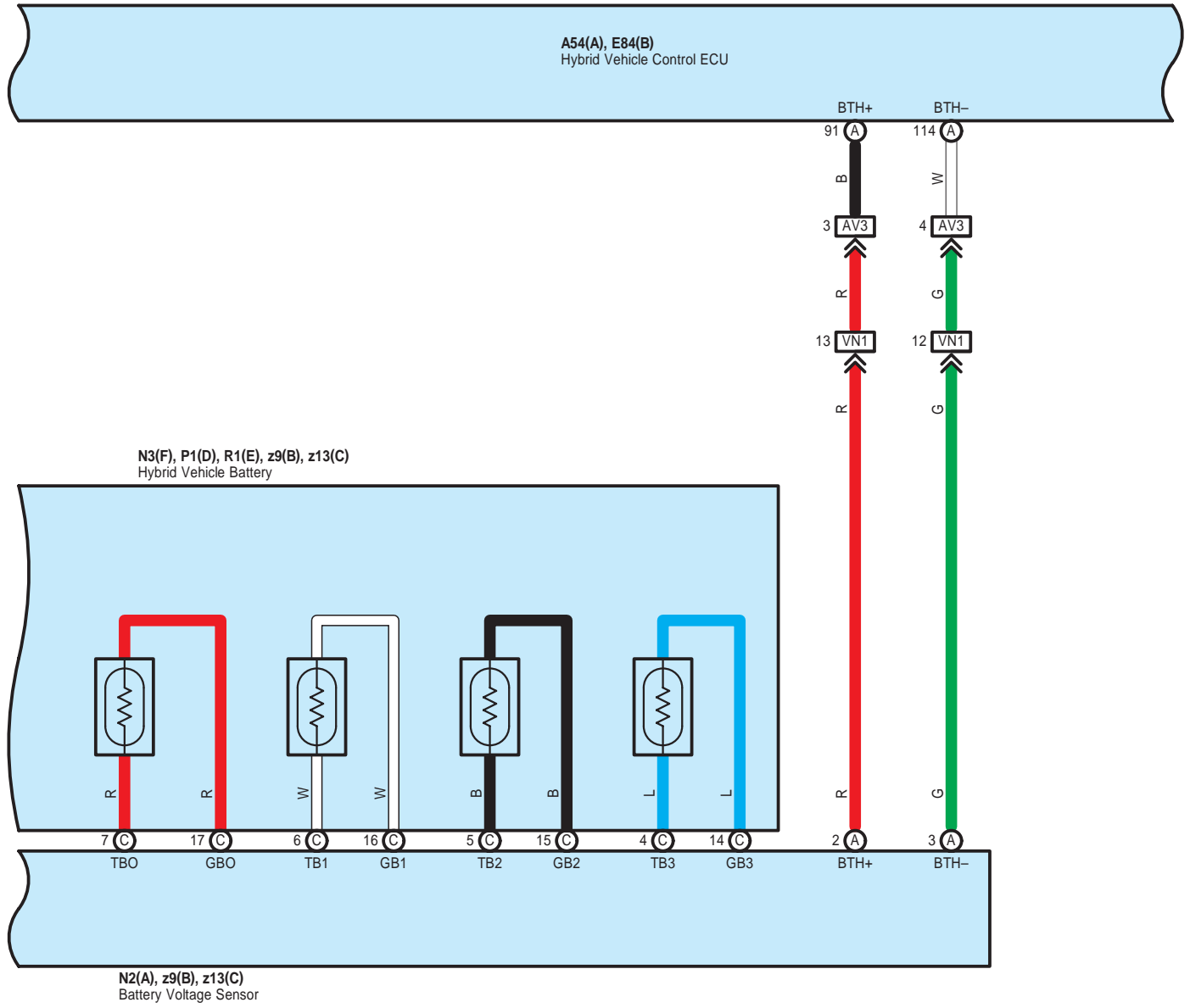

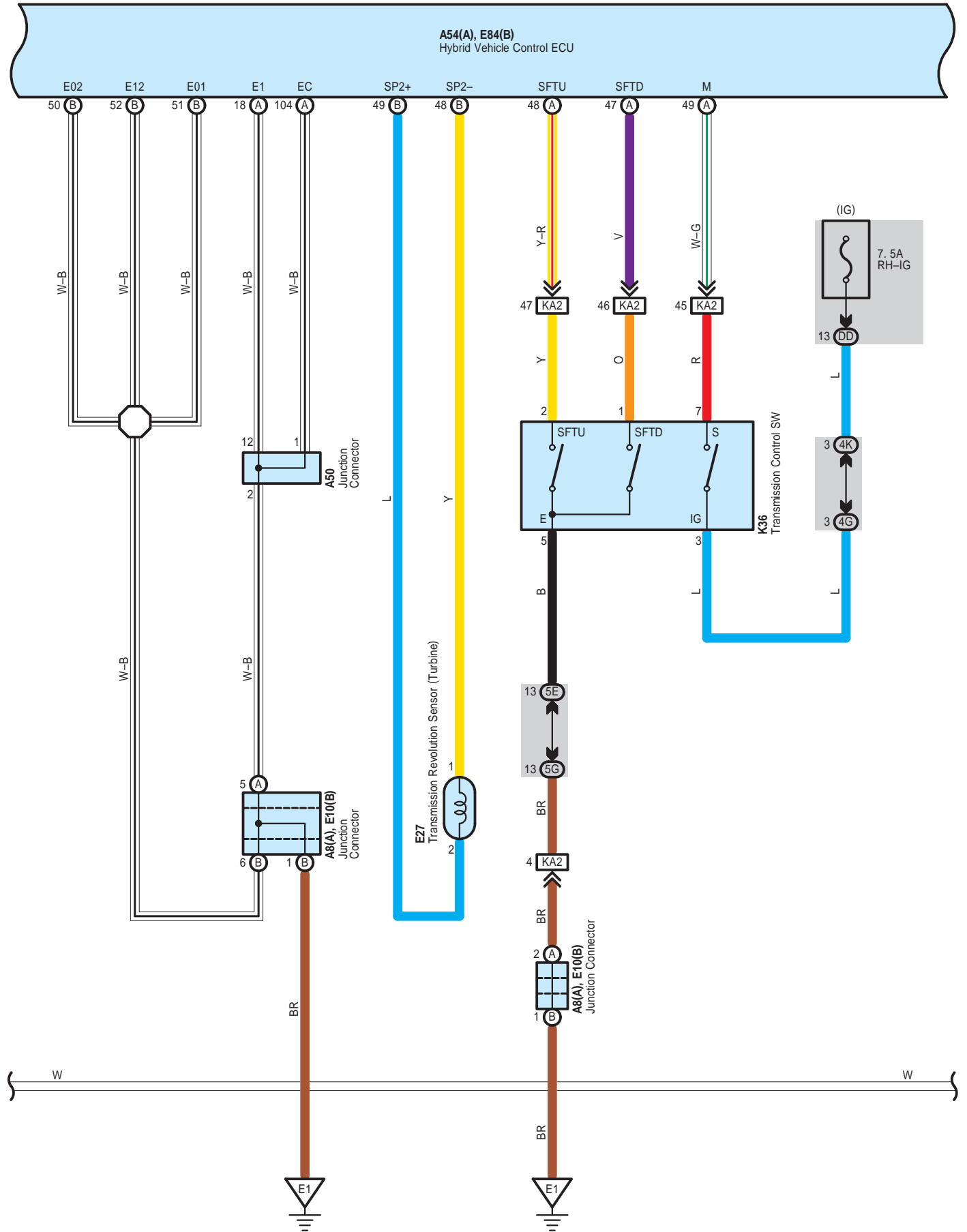

# Hybrid System and Shift Control System

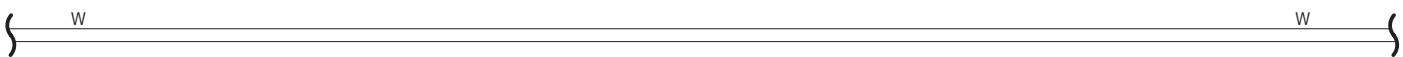
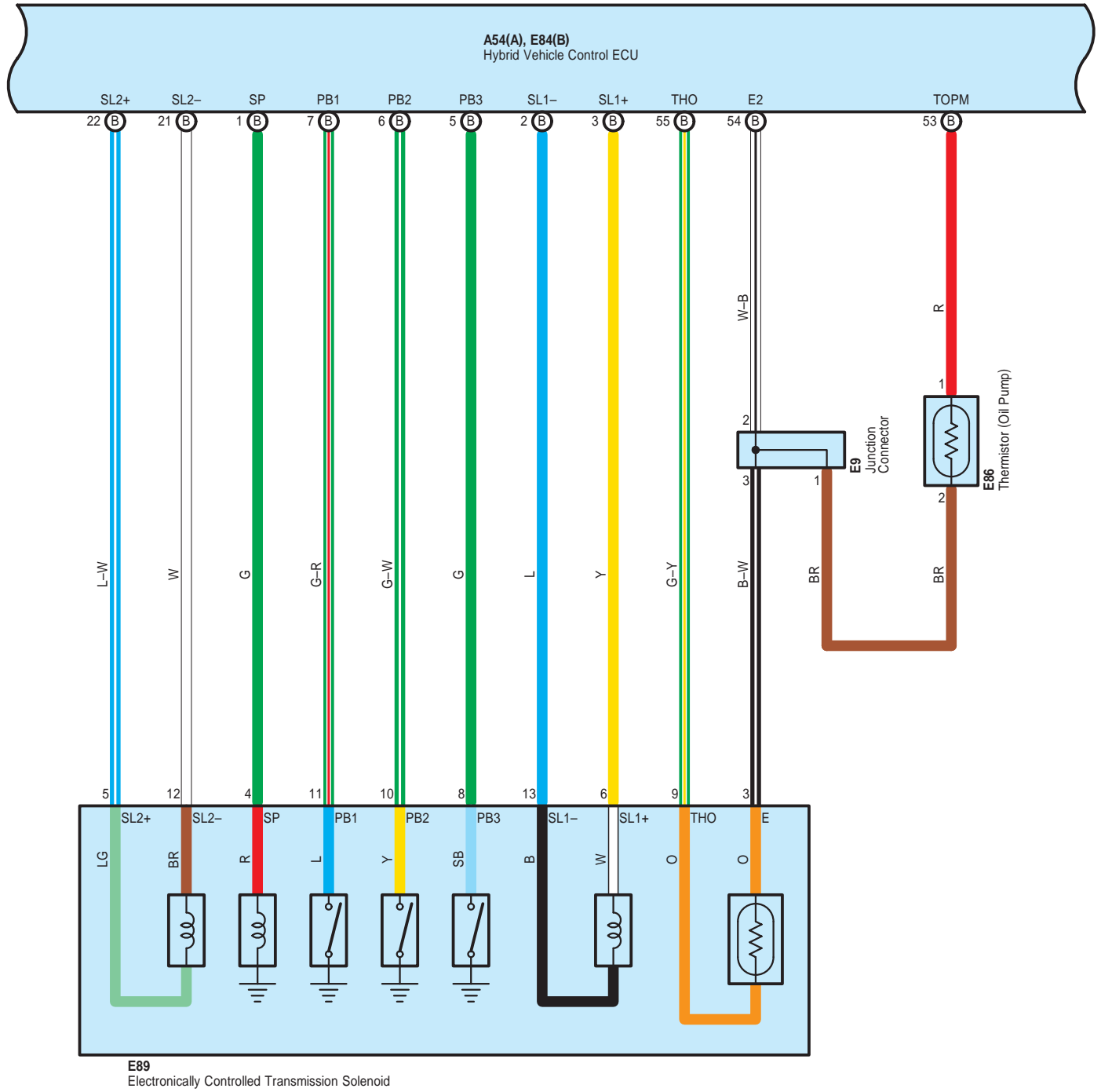

**A54(A), E84(B)**  
Hybrid Vehicle Control ECU

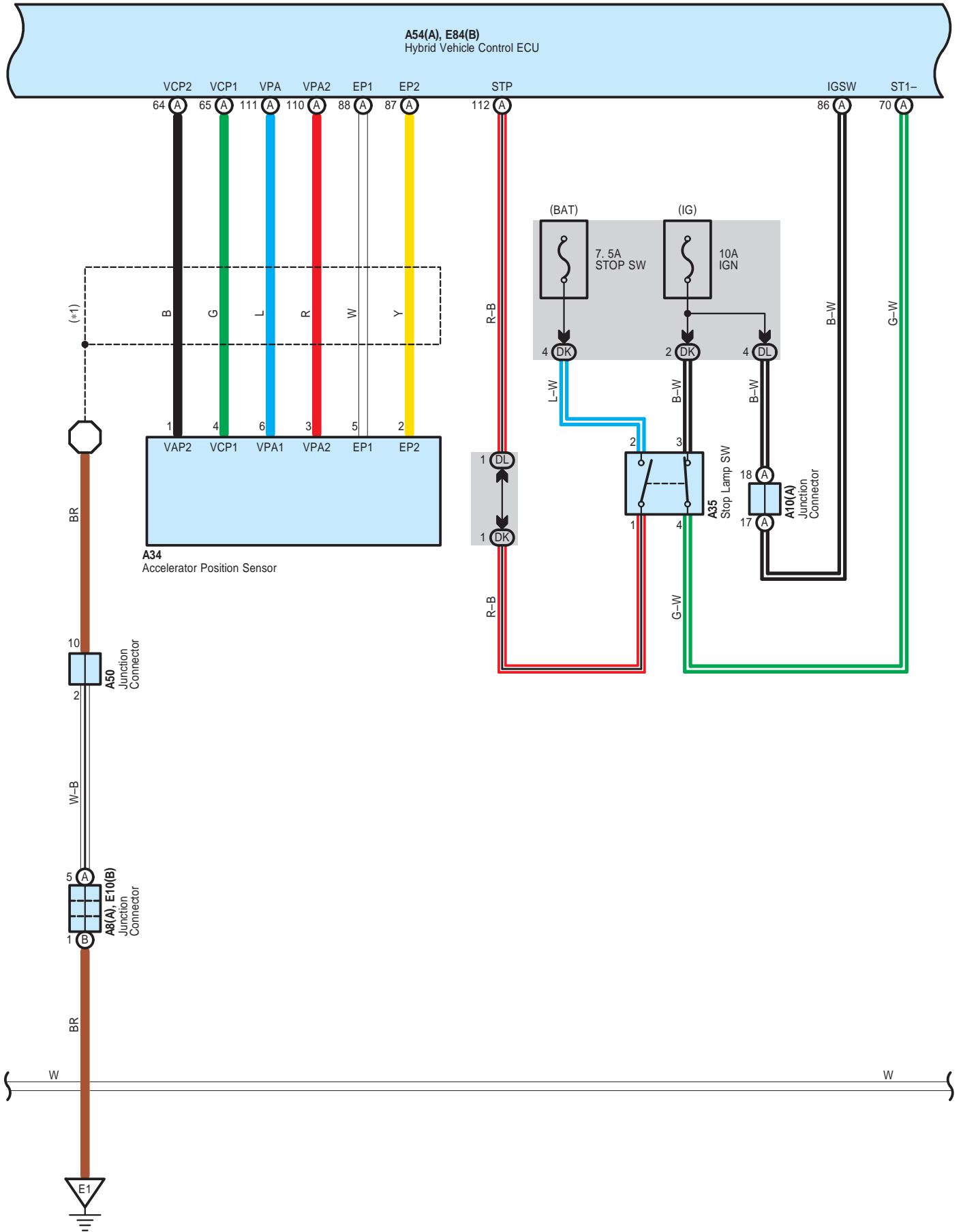

# Hybrid System and Shift Control System

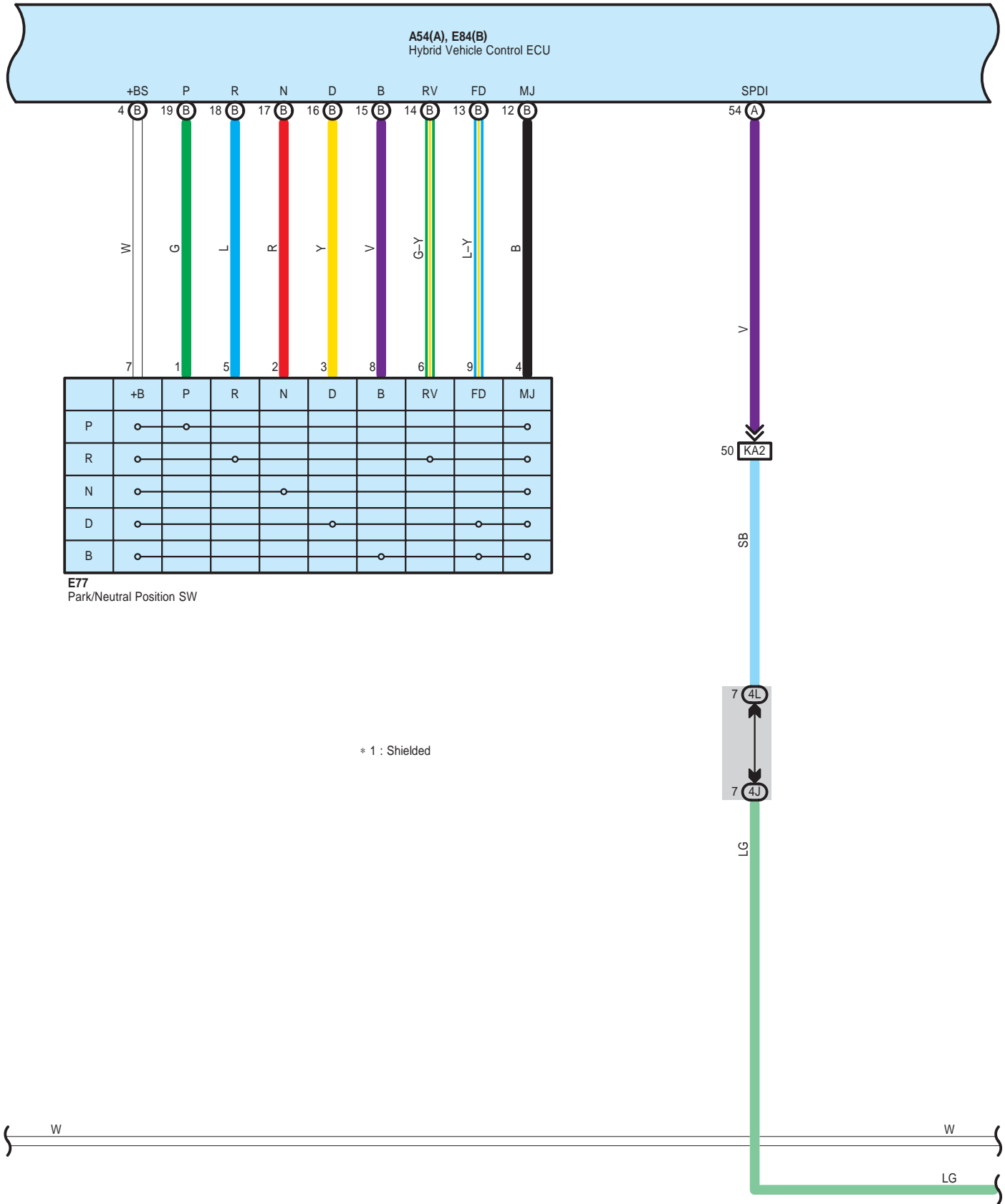

A54(A), E84(B)  
Hybrid Vehicle Control ECU

E39  
Throttle Body Assembly

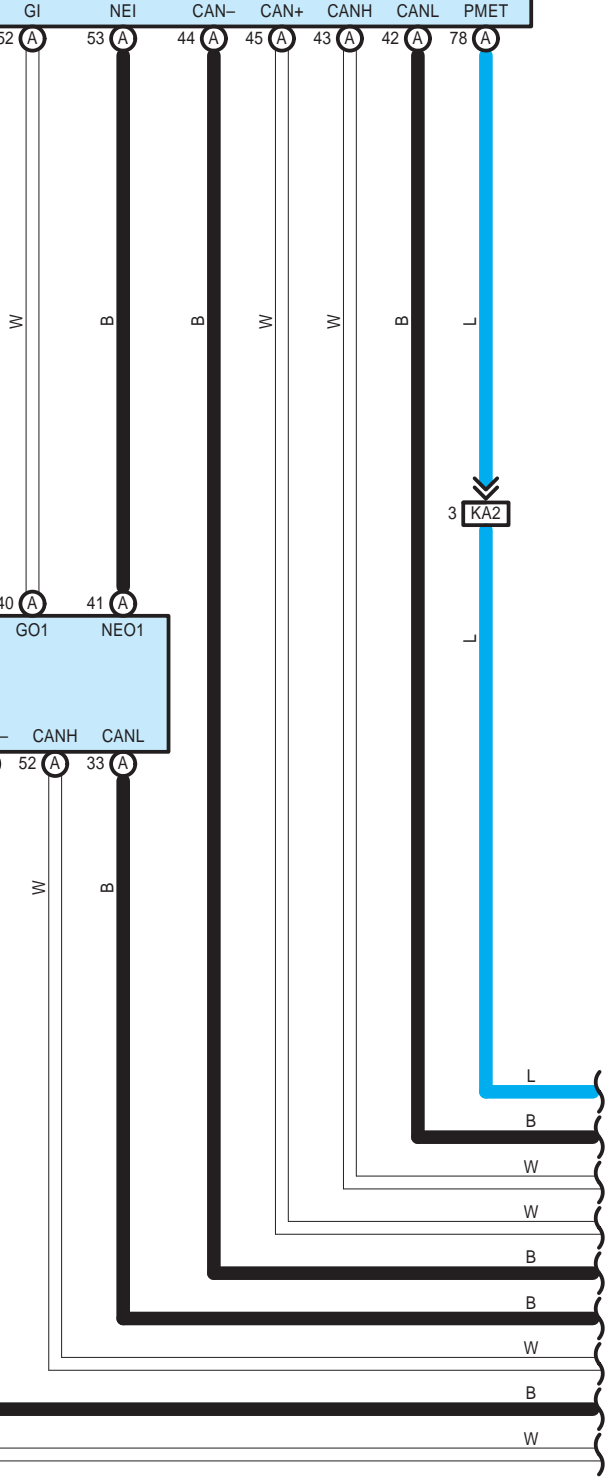
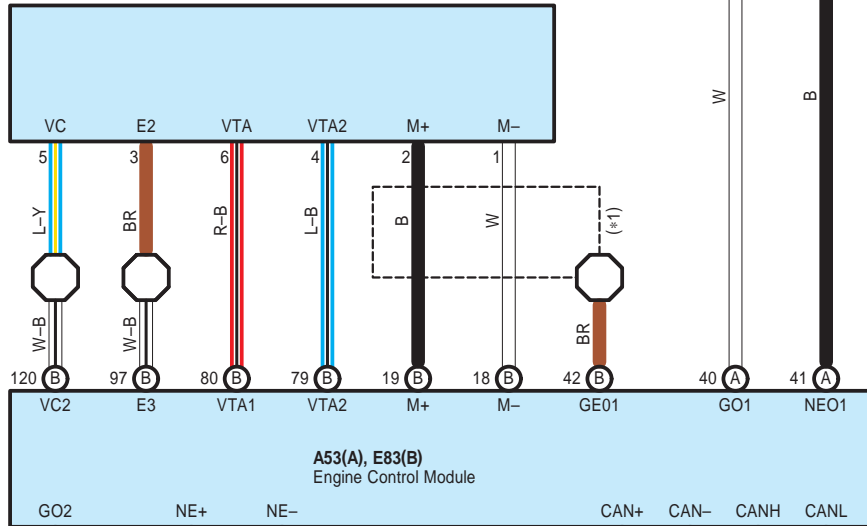



# Hybrid System and Shift Control System

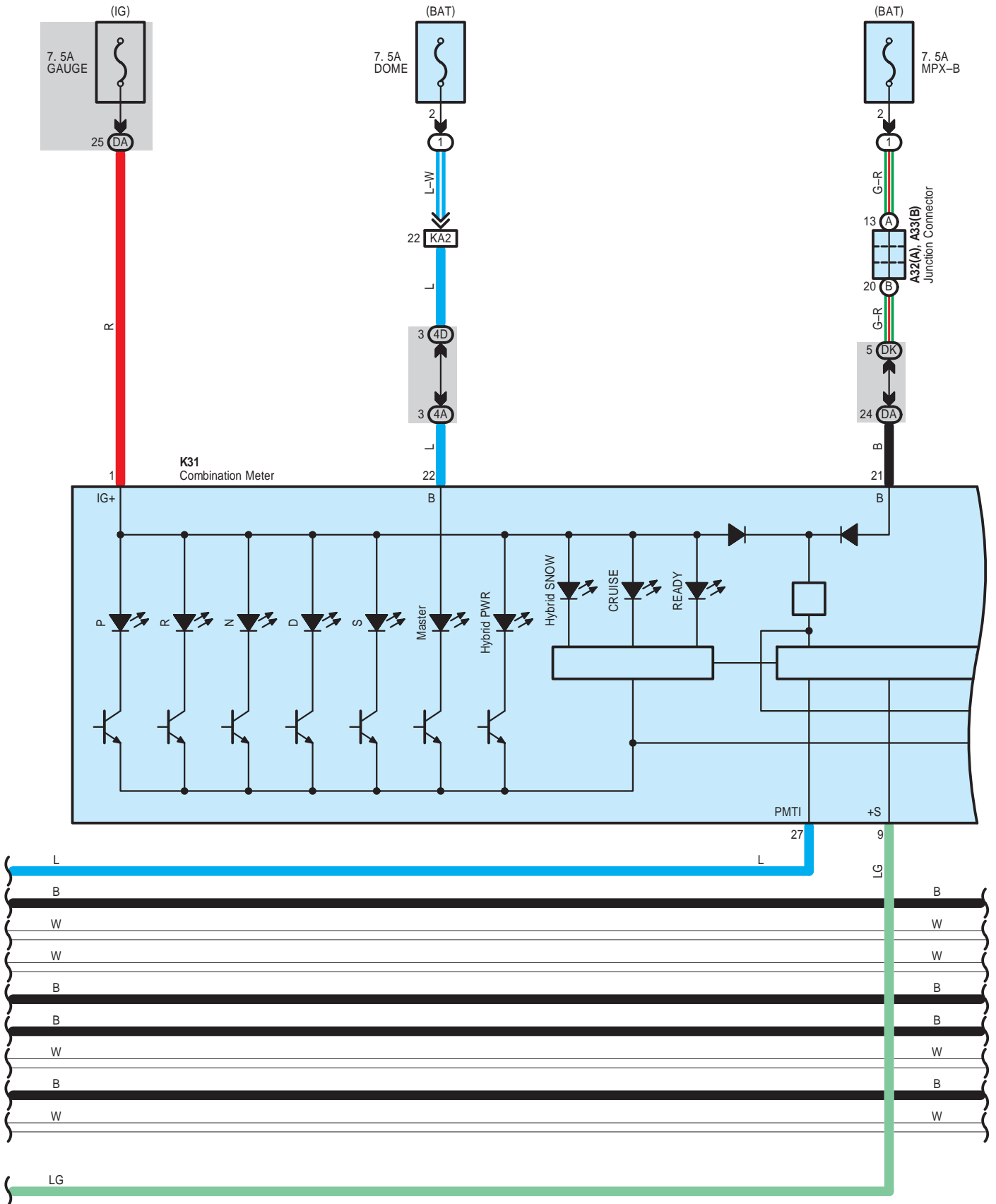

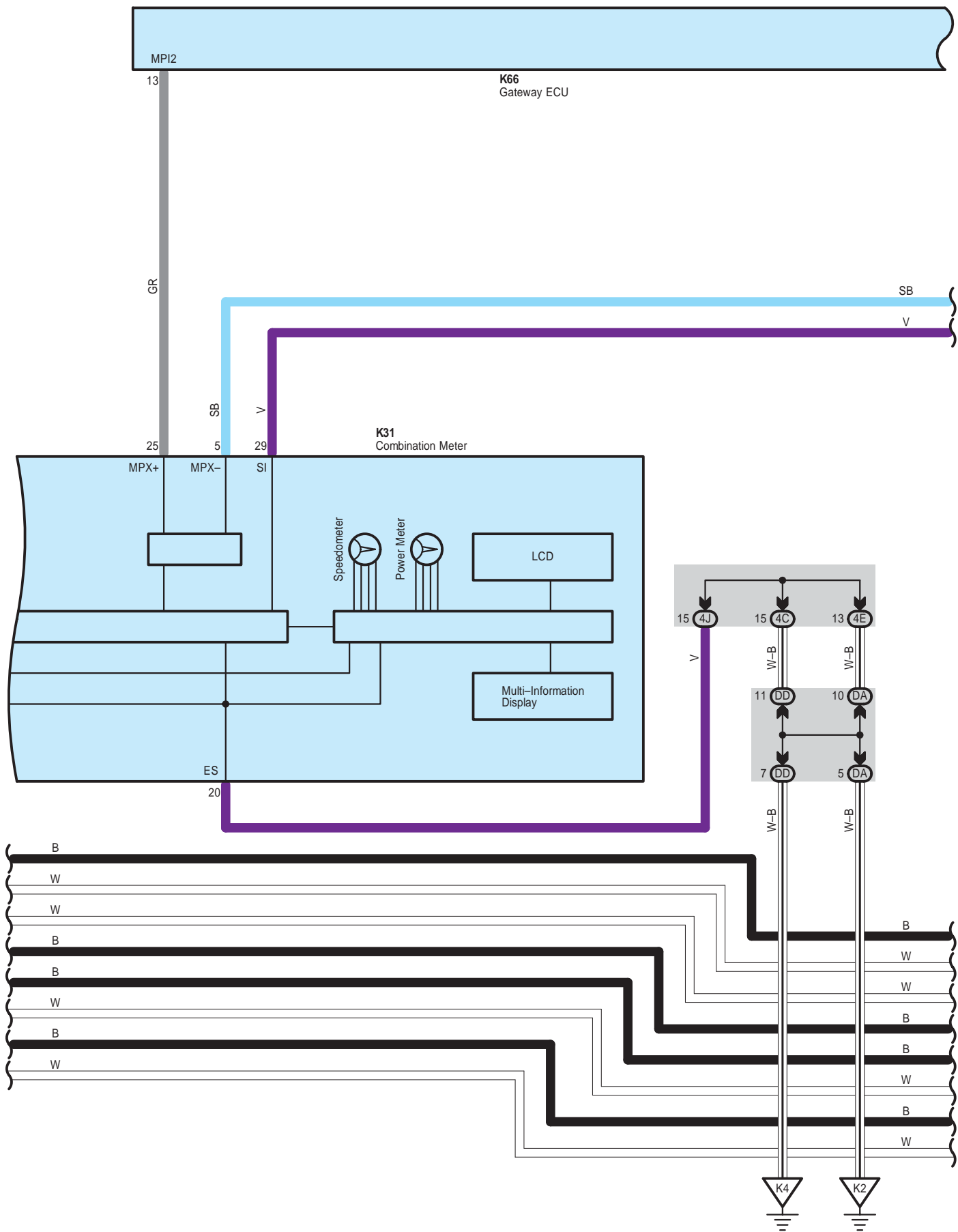

# Hybrid System and Shift Control System

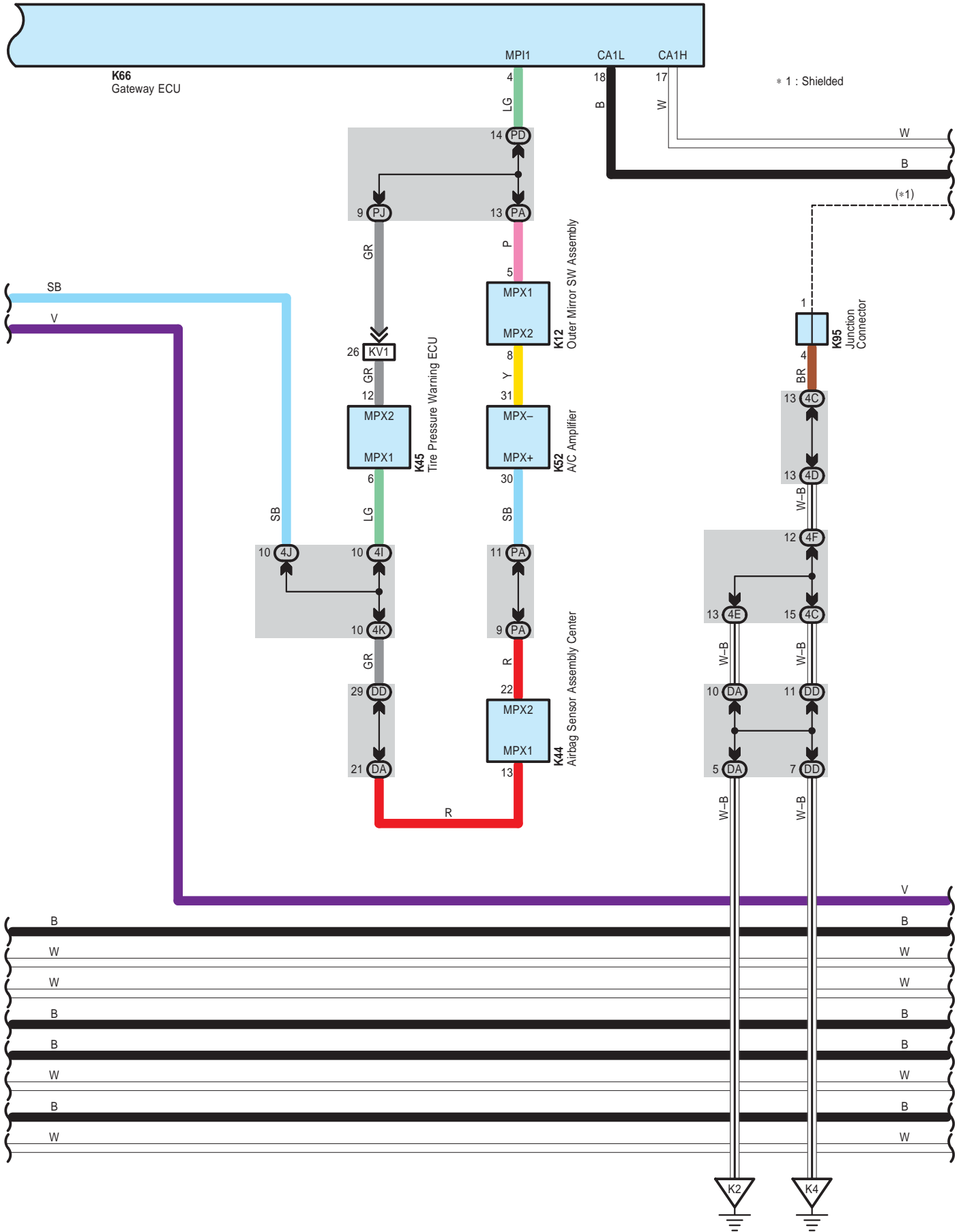

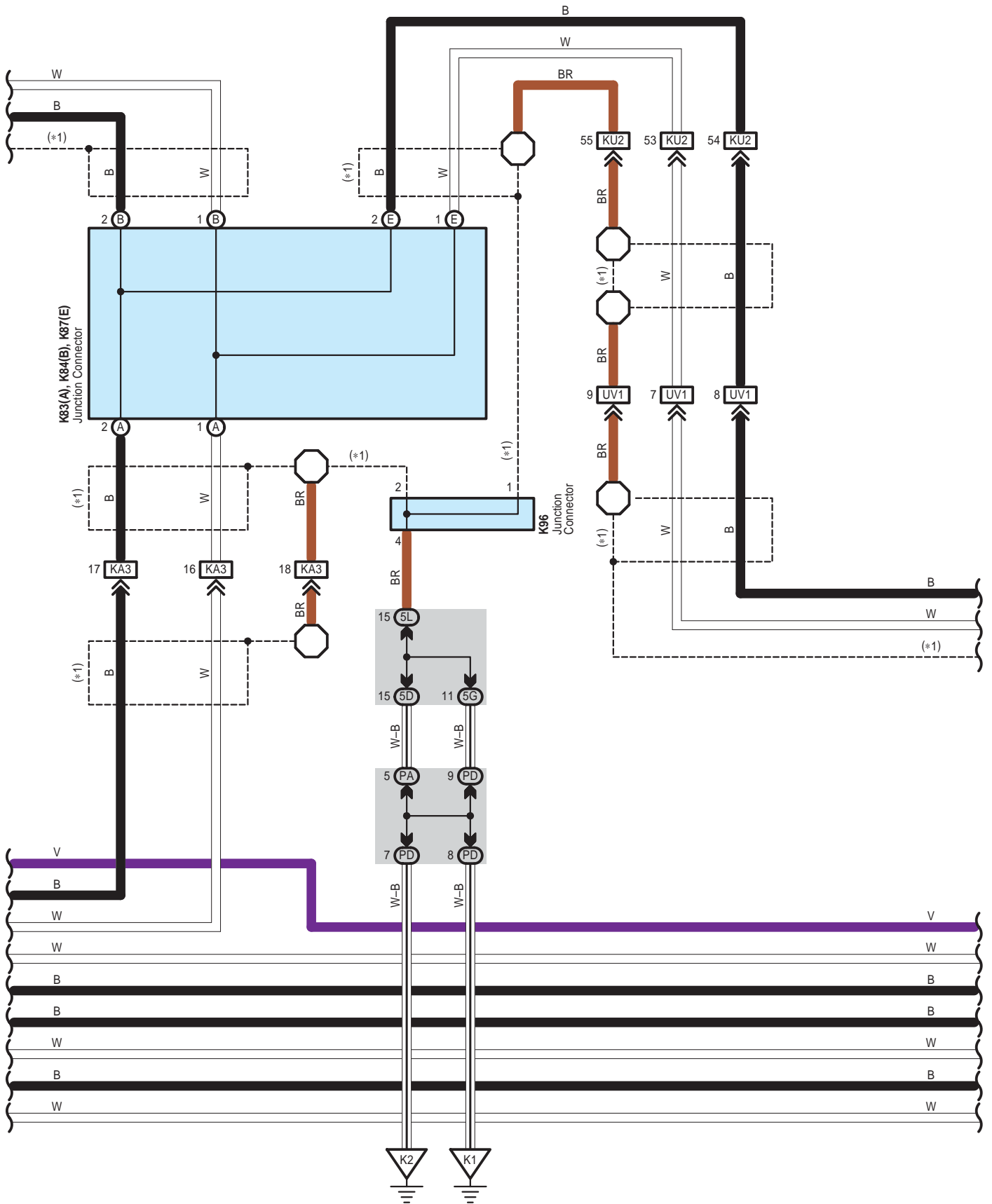

# Hybrid System and Shift Control System

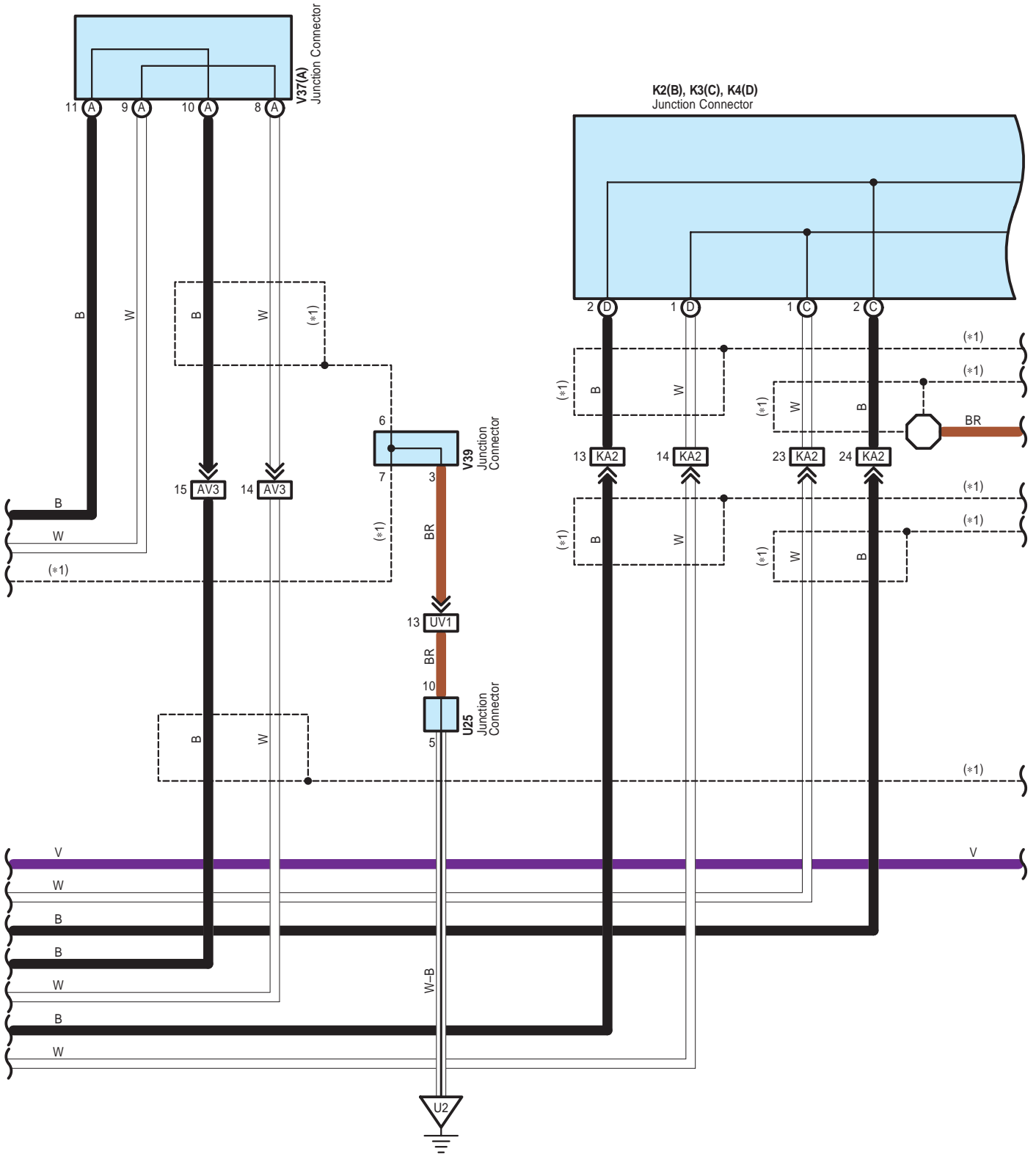

\* 1 : Shielded

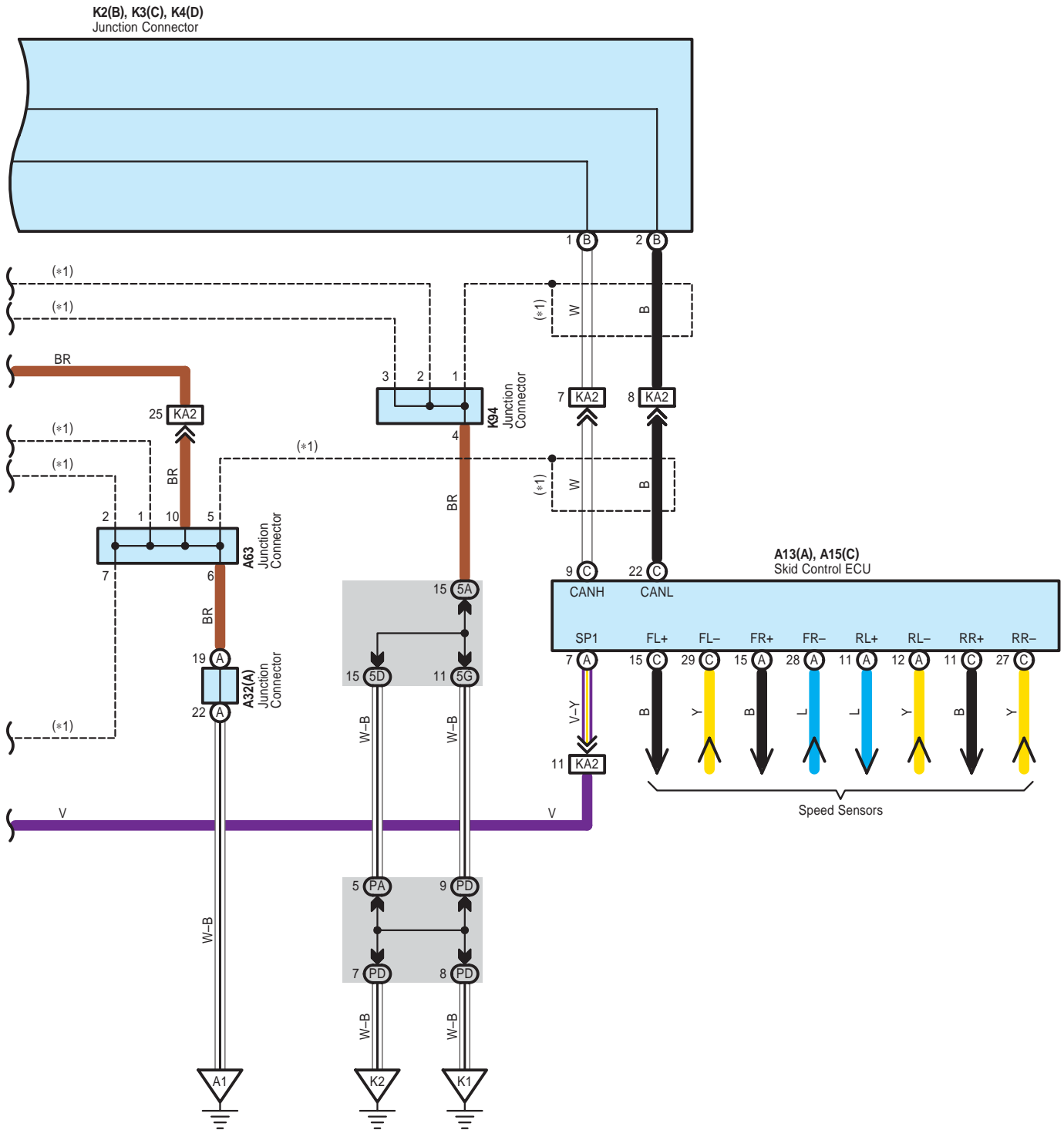

# Hybrid System and Shift Control System

## System Outline

The hybrid system is a power train to combine and use two different kinds of power sources such as gasoline engine and electric motor. The system uses optimum power source, either the gasoline engine or electric motor to fit the driving condition best and maximizes each one's strengths while compensating for each other's shortcomings. Thus, the driving performance with seamless response is attained and the fuel consumption and gas emission are reduced significantly at the same time.

## ○ : Parts Location

Code		See Page	Code		See Page	Code		See Page
A8	A	80	E86		81	N5		95
A9		80	E87		81	N6	F	95
A10	A	80	E88		81	N7	I	95
A11	B	80	E89		81	N8		95
A13	A	80	K2	B	74, 85	P1	D	95
A15	C	80	K3	C	74, 85	P2	G	95
A32	A	84	K4	D	74, 85	R1	E	95
A33	B	84	K12		85	R2	H	95
A34		84	K16		85	U25		90
A37		84	K31		85	V26	A	91
A49		80	K36		85	V27	B	91
A50		80	K44		86	V37	A	91
A53	A	80	K45		86	V39		91
A54	A	80	K52		86	X4		92
A55		80	K66		86	w1	B	83
A60	A	80	K83	A	78, 86	w4	K	95
A63		84	K84	B	78, 86	w5	J	95
E9		81	K87	E	78, 86	w6	B	95
E10	B	81	K94		86	w8	B	83
E27		81	K95		86	w9	C	83
E39		81	K96		86	z9	B	95
E47		81	N1	A	95	z10	C	95
E77		81	N2	A	95	z11	D	95
E83	B	81	N3	F	95	z12	E	95
E84	B	81	N4		95	z13	C	95

## ○ : Relay Blocks

Code	See Page	Relay Blocks (Relay Block Location)
1	24	Engine Room R/B No.1 (Engine Compartment Left)

 : Junction Block and Wire Harness Connector

Code	See Page	Junction Block and Wire Harness (Connector Location)
1P	27	Engine Room Main Wire and Engine Room J/B No.1 (Engine Compartment left)
1Q	27	Floor No.4 Wire and Engine Room J/B No.1 (Engine Compartment left)
1V	28	Engine Room Main Wire and Engine Room J/B No.1 (Engine Compartment left)
4A	70	Instrument Panel Wire and Center J/B RH (Right Side of the Instrument Panel Reinforcement)
4C		
4D		
4E		
4F		
4G		
4I		
4J		
4K		
4L		
5A	66	Instrument Panel Wire and Center J/B LH (Right Side of the Instrument Panel Reinforcement)
5D		
5E		
5G		
5L		
DA	55	Instrument Panel Wire and Cowl Side J/B RH (Behind the Glove Box)
DD		
DK	56	Engine Room Main Wire and Cowl Side J/B RH (Behind the Glove Box)
DL		
PA	49	Instrument Panel Wire and Cowl Side J/B LH (Lower Finish Panel)
PD		
PJ	50	Floor No.2 Wire and Cowl Side J/B LH (Lower Finish Panel)
PL	50	Engine Room Main Wire and Cowl Side J/B LH (Lower Finish Panel)

 : Connector Joining Wire Harness and Wire Harness

Code	See Page	Joining Wire Harness and Wire Harness (Connector Location)
AE1	96	Engine Room Main Wire and Engine Wire (Inside of the ECU Box)
AV3	97	Engine Room Main Wire and Floor No.2 Wire (Cowl Side Panel LH)
EA2	96	Engine Wire and Engine Room Main Wire (Engine Compartment Right)
EA3		
KA2	97	Instrument Panel Wire and Engine Room Main Wire (Left Kick Panel)
KA3	97	Instrument Panel Wire and Engine Room Main Wire (Right Kick Panel)
KU2	97	Instrument Panel Wire and Floor No.1 Wire (Right Kick Panel)
KV1	97	Instrument Panel Wire and Floor No.2 Wire (Left Kick Panel)
UV1	98	Floor No.1 Wire and Floor No.2 Wire (Center of the Rear Floor Partition Panel)
VN1	100	Floor No.2 Wire and Seat No.1 Wire (Near the Hybrid Vehicle Battery)
VX1	98	Floor No.2 Wire and Luggage Room Wire (Quarter Wheel House Inner Panel LH)



# Hybrid System and Shift Control System

---



: Ground Points

Code	See Page	Ground Points Location
A1	96	Left Side of the Dash Panel
A2	96	Front Left Fender Apron
A4	96	Front Right Fender Apron
E1	96	Rear Side of the Left Cylinder Head
K1	97	Left Kick Panel
K2	97	Left Side of the Shift Lever
K4	97	Right Kick Panel
U2	98	Right Side of the Rear Floor Partition Panel
V2	98	Roof Side Inner Panel LH

