

FRONT FENDER APRON (ASSY)

REMOVAL (With the radiator side support and front body pillar lower gusset removed.)

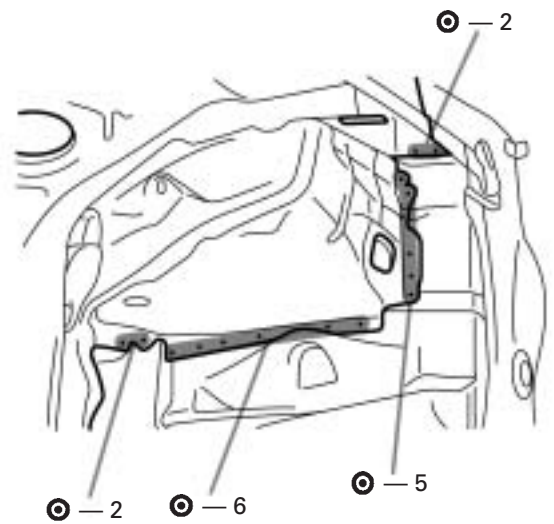

INSTALLATION

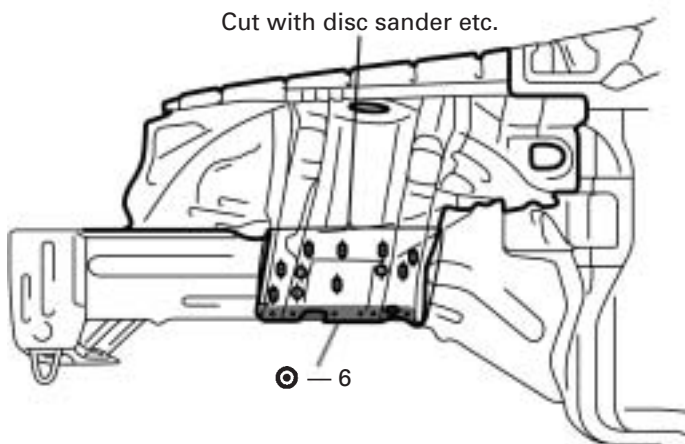
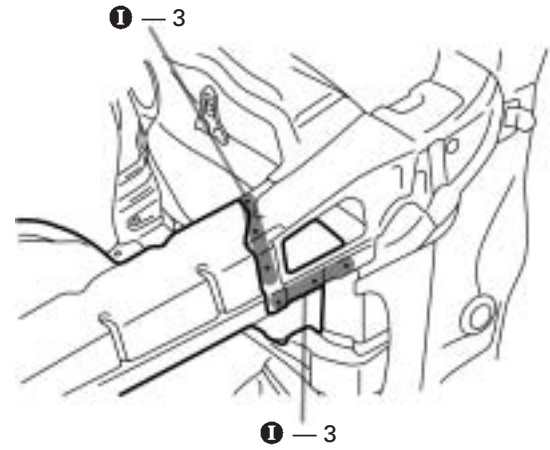
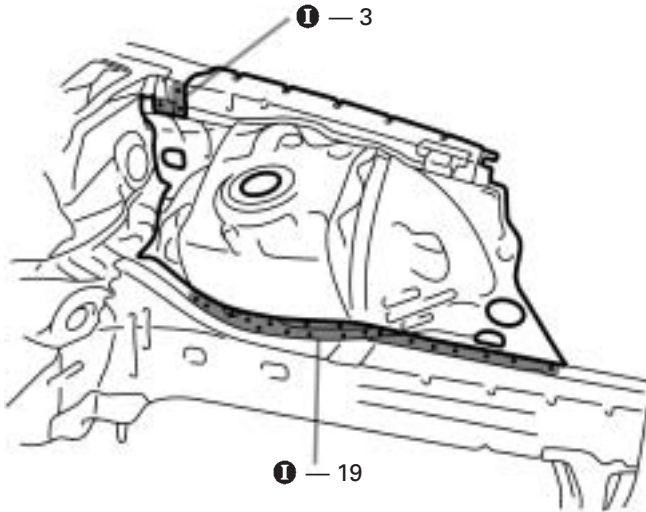
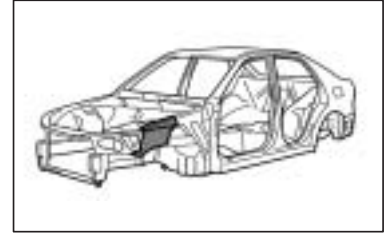
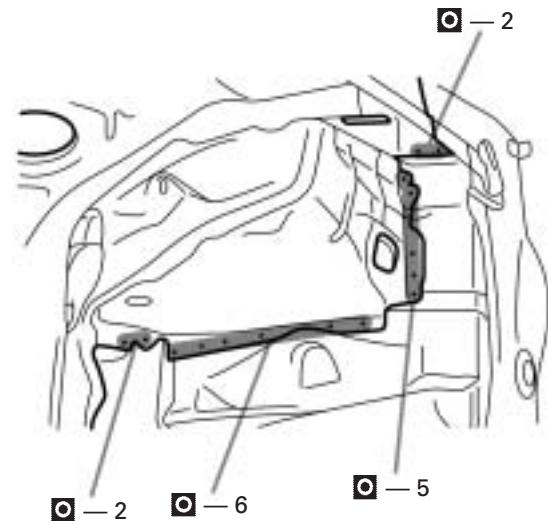
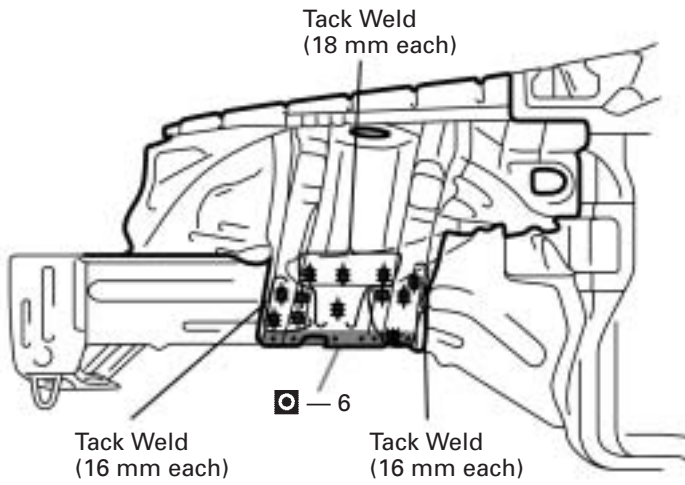
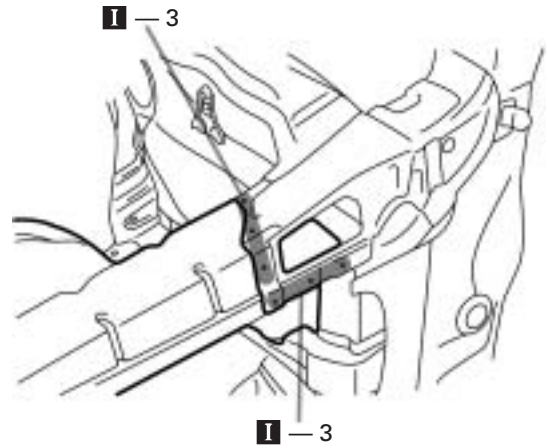
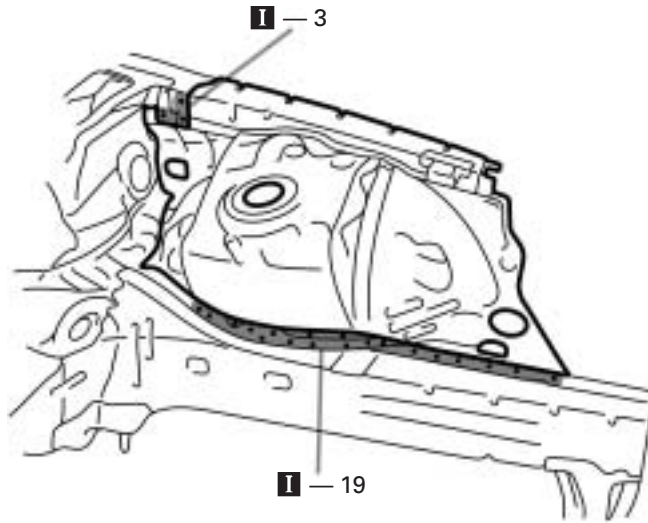

mm	in.
16	0.63
18	0.71

1. Temporarily install the new parts and measure each part in accordance with the body dimension diagram.
2. Measurements must be accurate with the body dimension diagram, as this affects the front wheel alignment.
3. Temporarily install the front fender and hood, and check the fit.