

FRONT SIDE MEMBER (CUT-P)

REMOVAL (With the front crossmember and front fender front apron removed.)

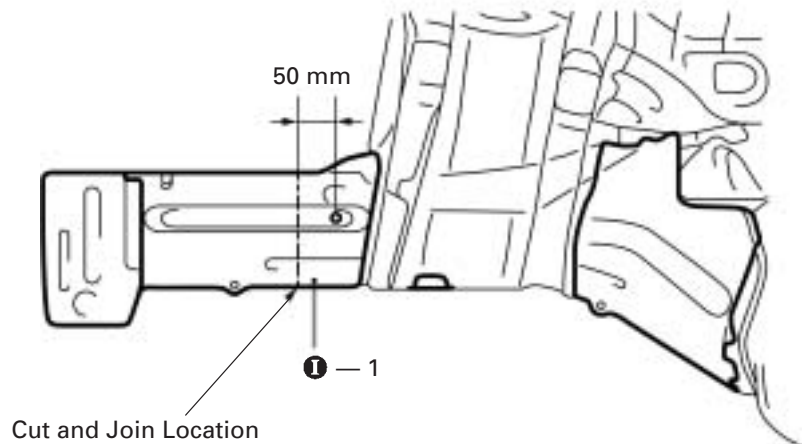
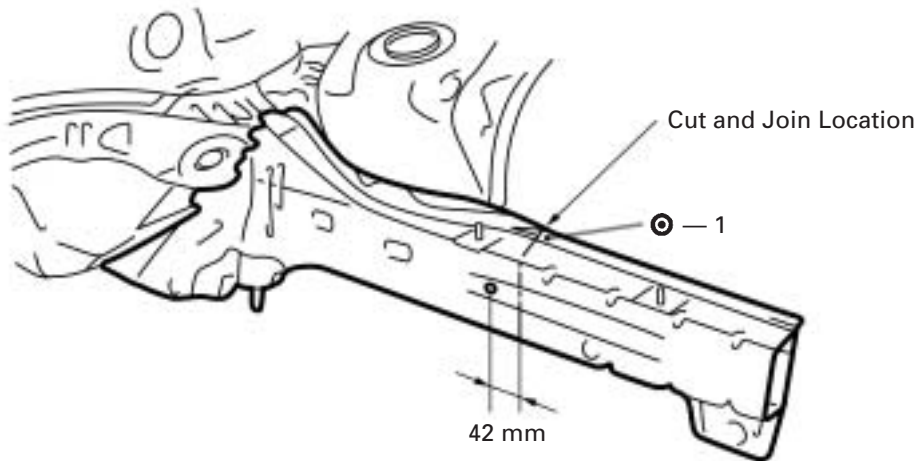
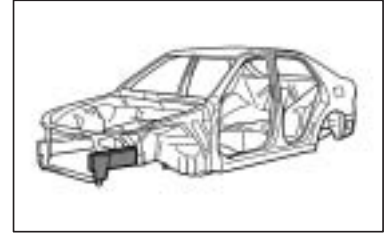

1. Cut and join the parts at the locations as shown above.

mm	in.
42	1.65
50	1.97

INSTALLATION

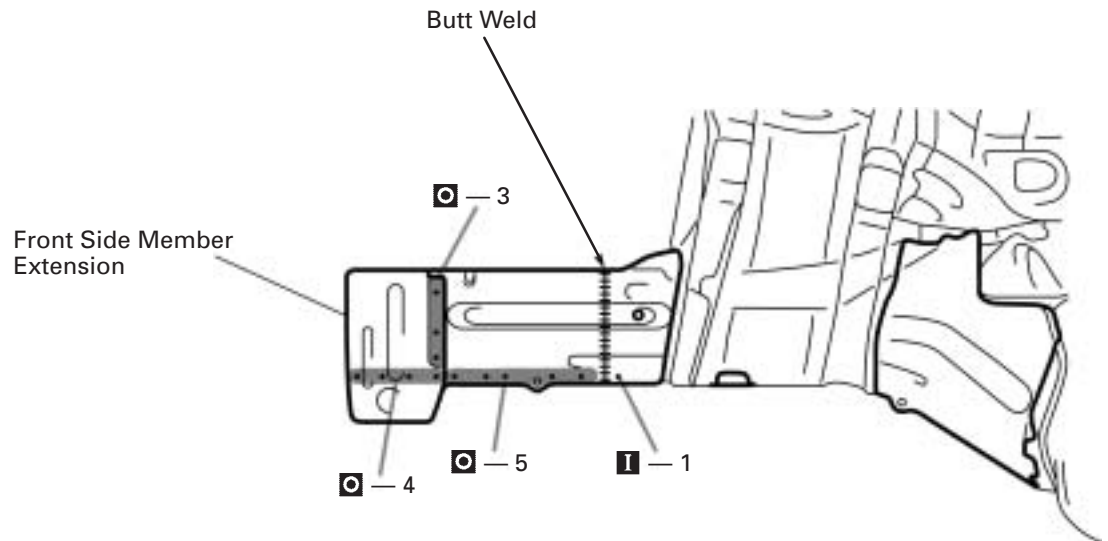
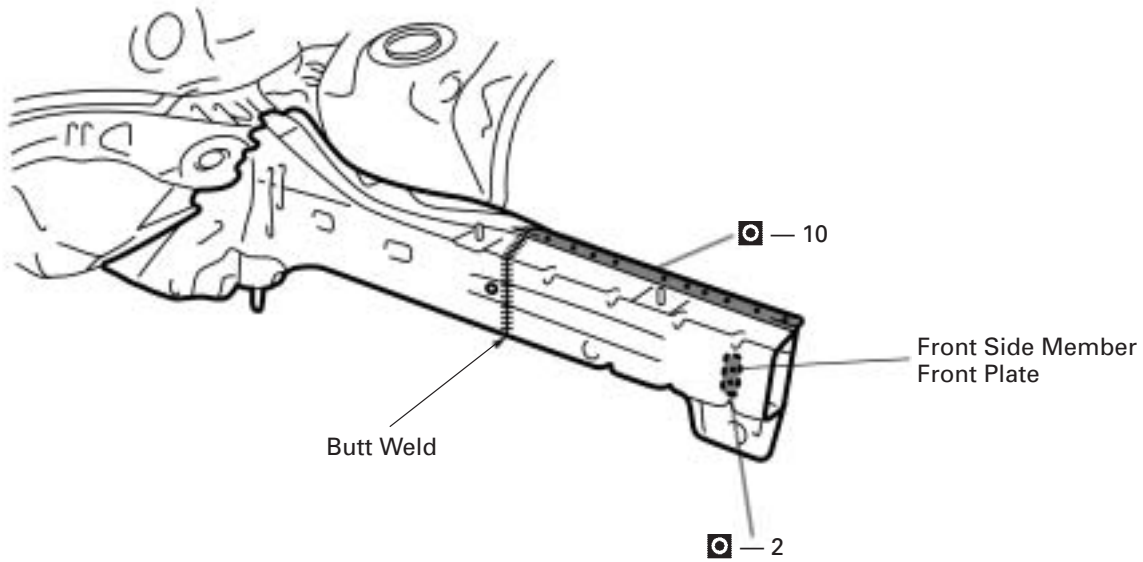

1. Temporarily install the new parts and measure each part in accordance with the body dimension diagram.

- MEMO -