

COWL TOP SIDE PANEL (ASSY)

REMOVAL (With the cowl top to apron brace and front body pillar lower gusset removed.)

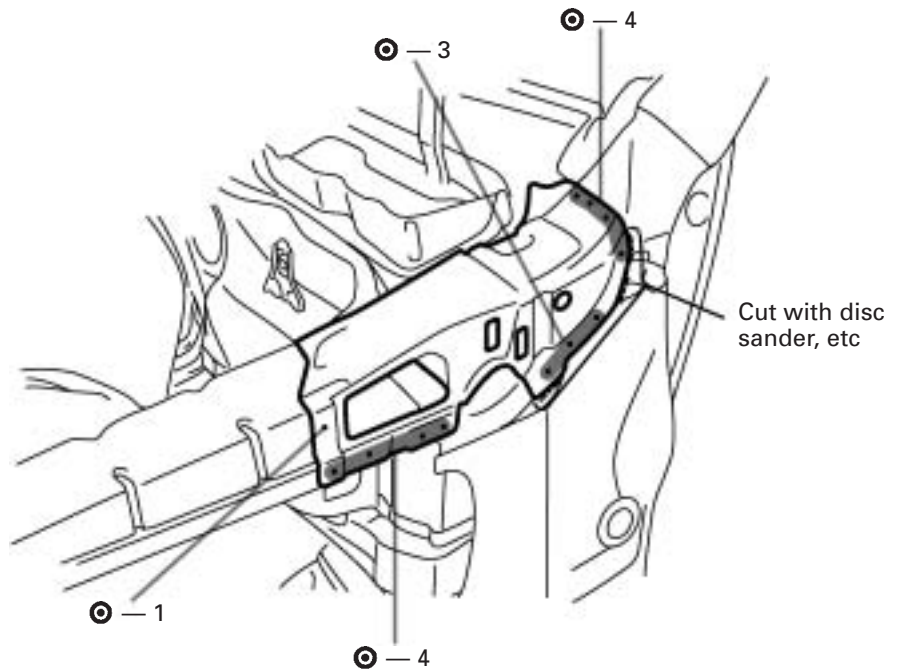

INSTALLATION

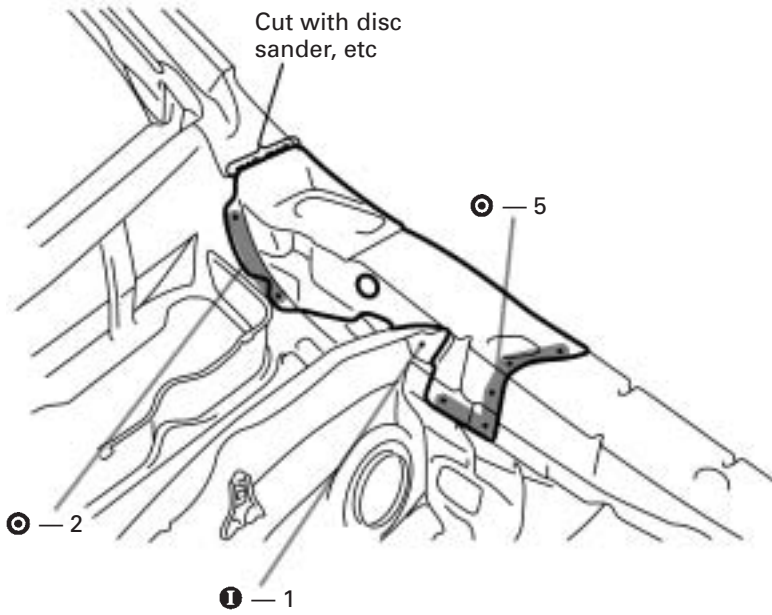
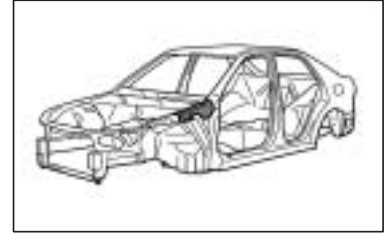
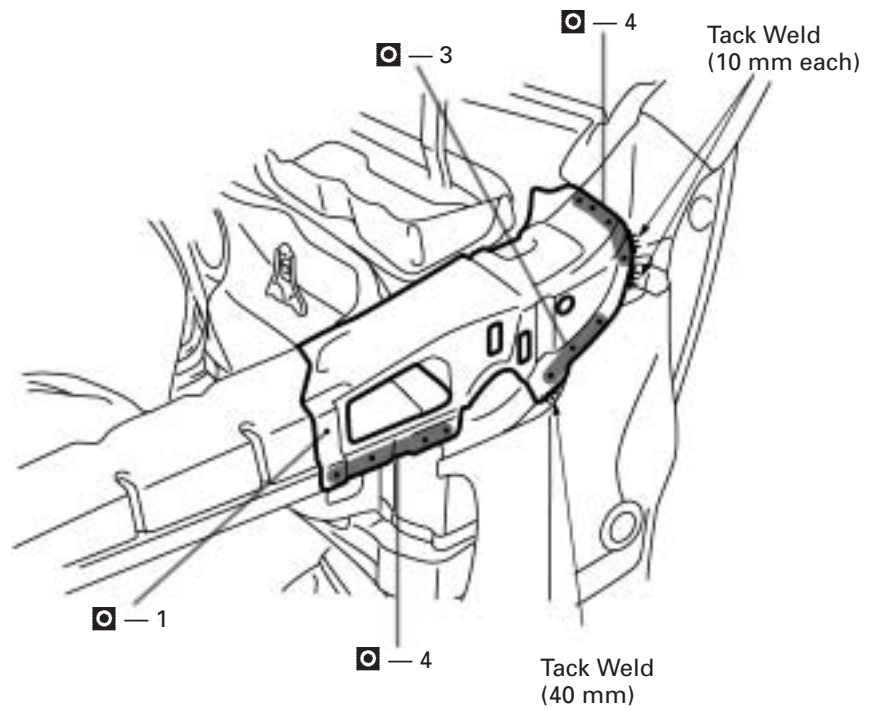
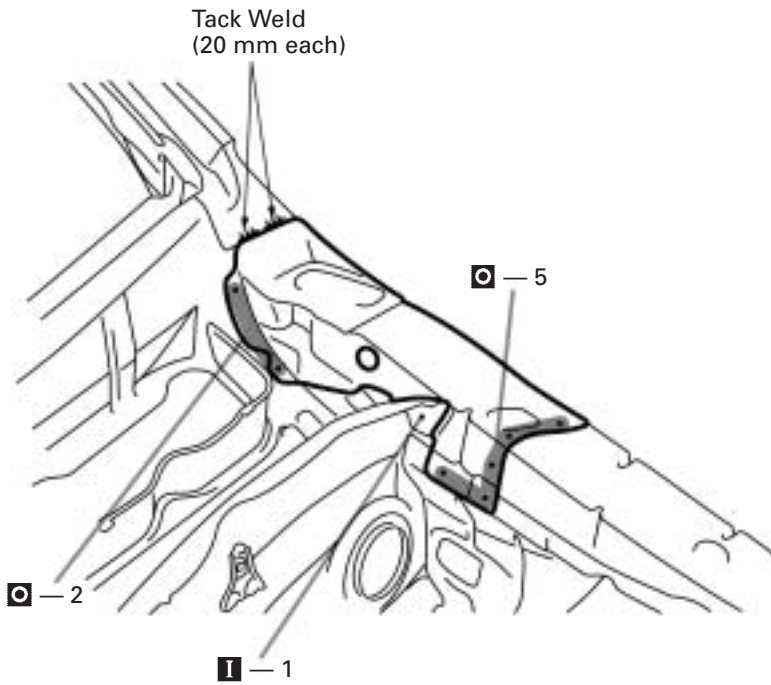

mm	in.
10	0.39
20	0.79
40	1.57