

ROCKER OUTER PANEL (CUT)

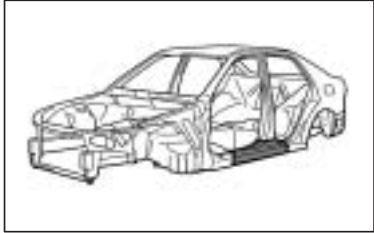

REMOVAL

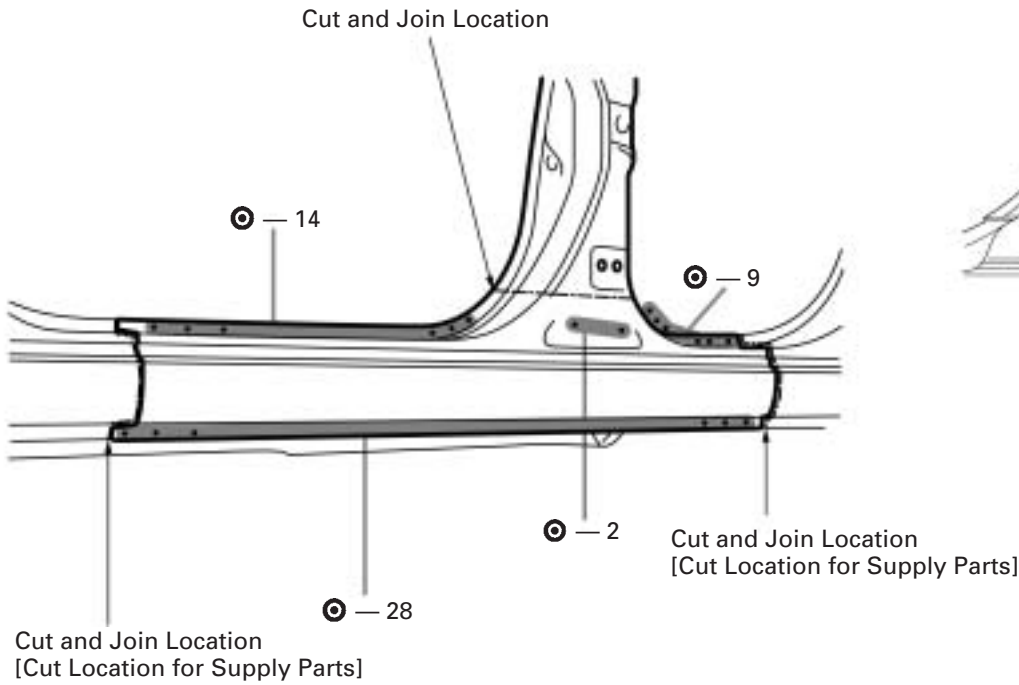

[Cut and Join Location]

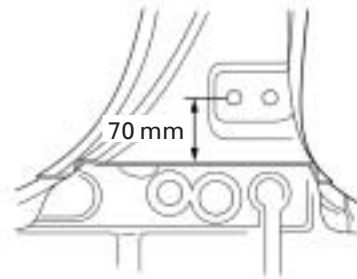

Cut and Join Location
[Cut Location for Supply Parts]

[Cut and Join Location]

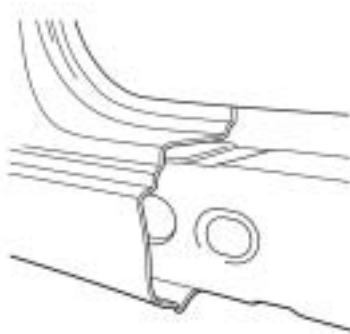

[Cut and Join Location]



1. Cut and join the parts at the locations as shown above.

HINT: Take care not to damage the internal reinforcement of the rocker panel and center body pillar.

mm	in.
70	2.76

INSTALLATION

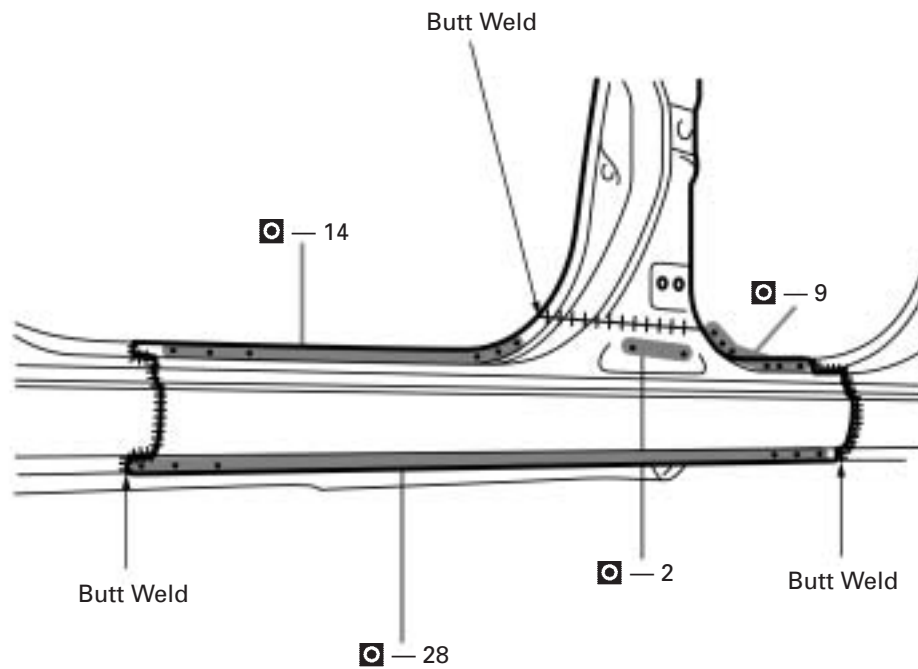

1. Temporarily install the new parts and check the fit of the front door and rear door.