

**REAR FLOOR PAN (ASSY)****REMOVAL (With the body lower back panel removed.)**

INSTALLATION

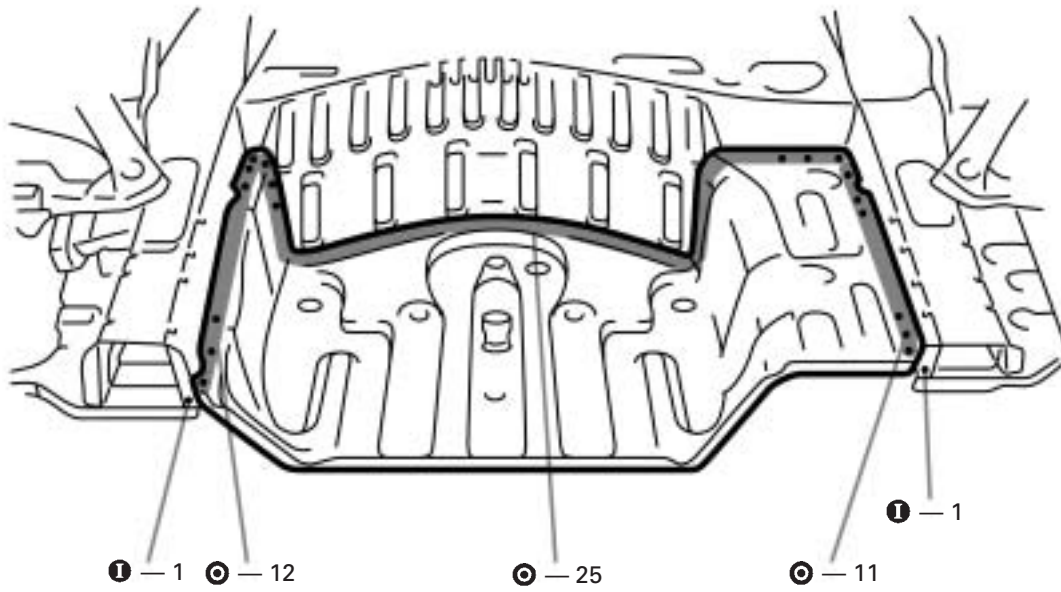
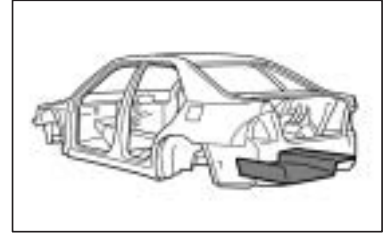
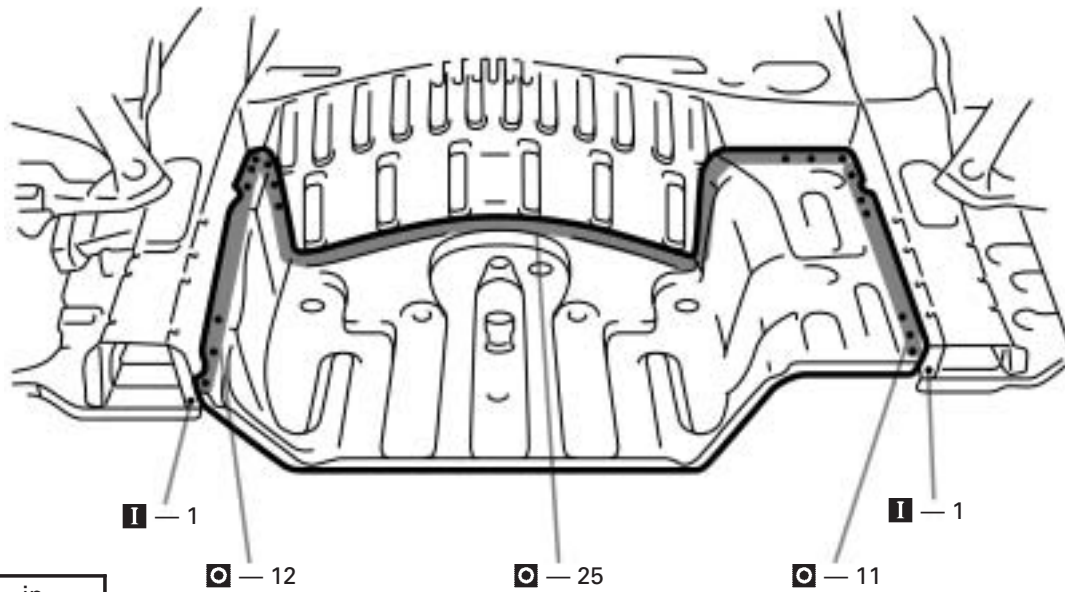
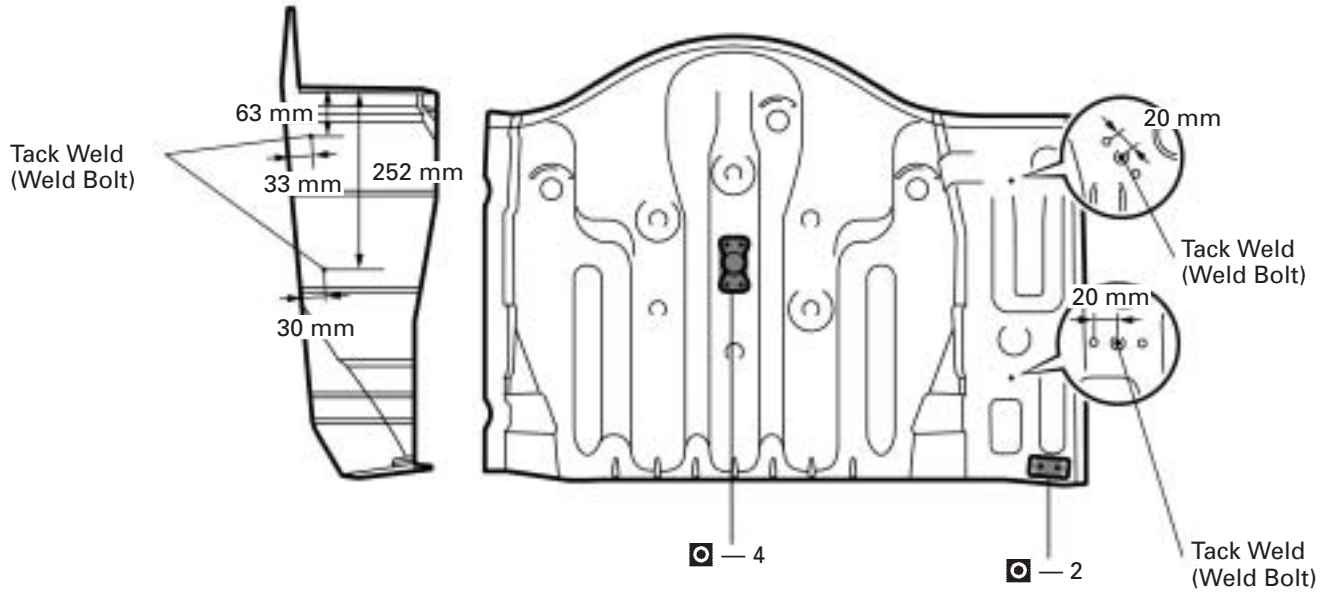

mm	in.
20	0.79
30	1.18
33	1.30
63	2.48
252	9.92

1. Install the weld bolt in the position shown on the above diagram.
2. Before welding the weld bolts, check the fit of the aerodynamic parts.

- MEMO -