

ROOF PANEL (ASSY): w/ Moon Roof

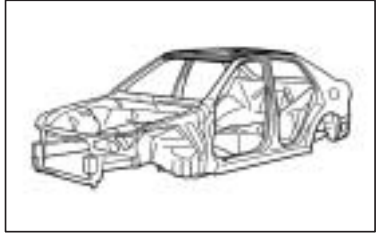

REMOVAL

[If reusing the roof panel reinforcement]

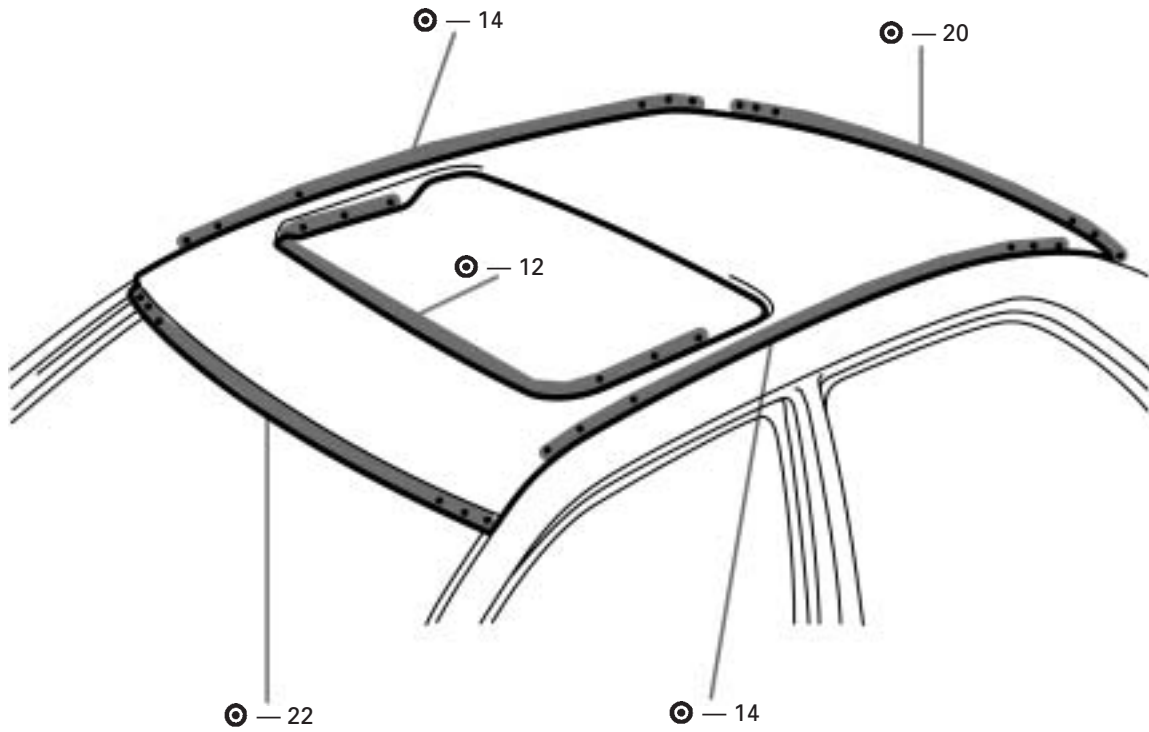
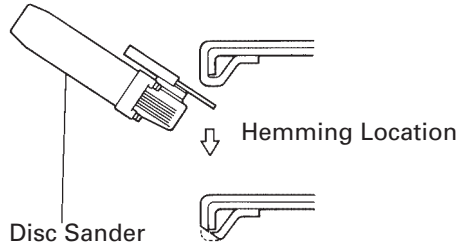

INSTALLATION

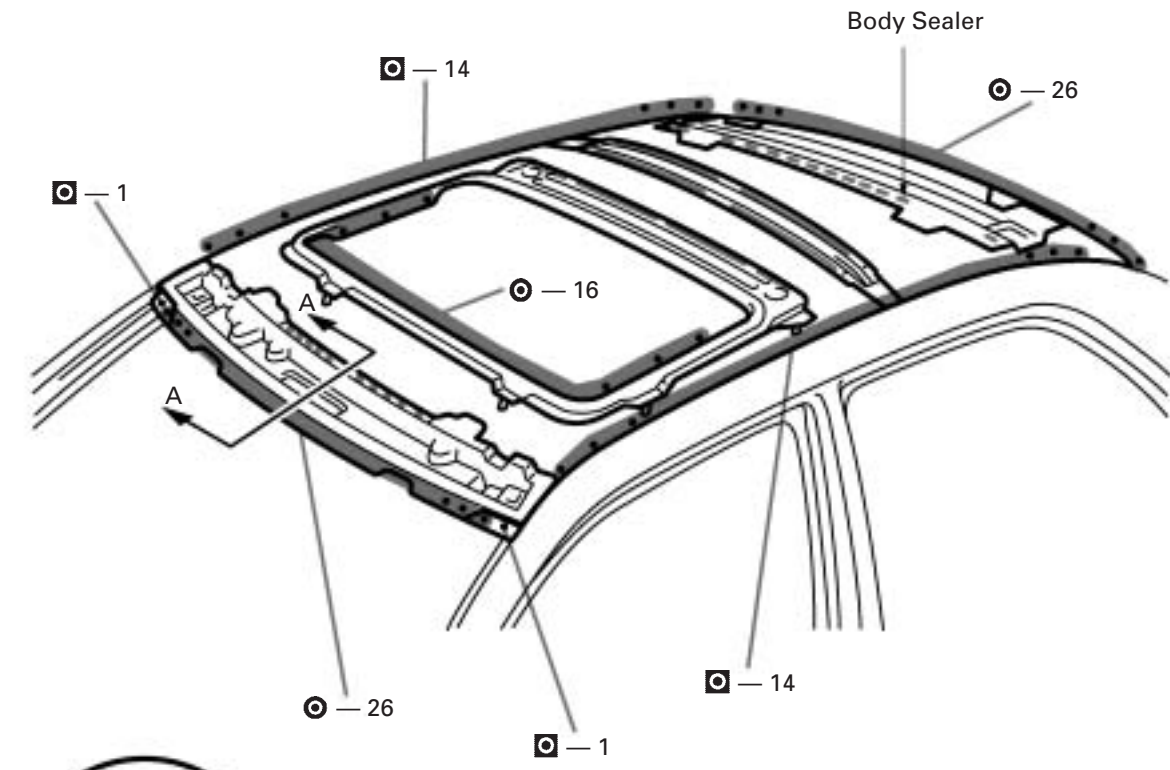

A - A
[Foamed Materials Application Area]

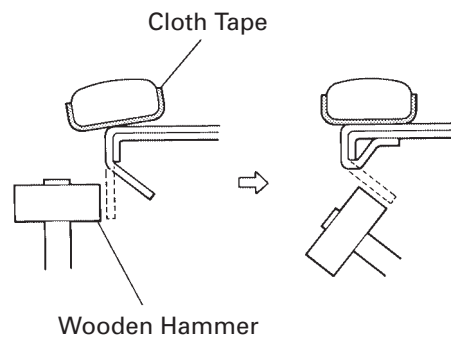

1. Before temporarily installing the new parts, apply body sealer to the windshield header panel, roof panel reinforcement and back window frame.

HINT: Apply just enough sealer for the new parts to make contact.

2. After installing the new parts, apply foamed materials.
3. Bend the flange hem with a wooden hammer and dolly.

HINT: Perform hemming three steps, being careful not to warp the panel.

