

## REMOVAL

1. RUN ENGINE AT IDLE SPEED WITH A/C ON FOR APPROX. 10 MINUTES
2. STOP ENGINE
3. DISCONNECT NEGATIVE (-) TERMINAL CABLE FROM BATTERY
4. DISCHARGE REFRIGERANT FROM REFRIGERATION SYSTEM
5. REMOVE ENGINE UNDER COVER
6. REMOVE DRIVE BELT (See page AC-17)

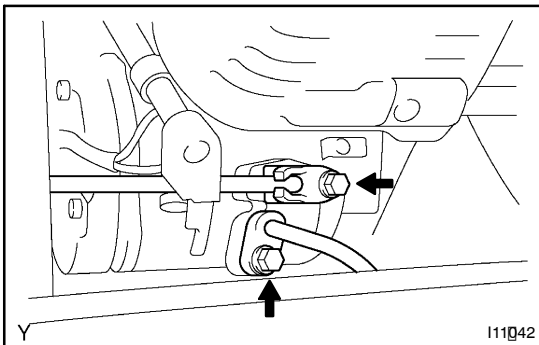

### 7. DISCONNECT DISCHARGE AND SUCTION HOSES

Remove the 2 bolts and disconnect the both hoses.

#### NOTICE:

Cap the open fitting immediately to keep moisture or dirt out of the system.

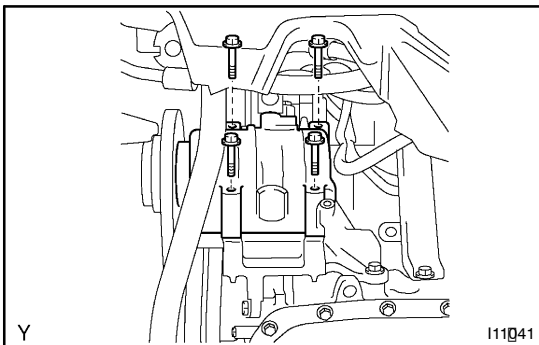

### 8. REMOVE COMPRESSOR

- (a) Disconnect the connector.
- (b) Remove the 4 bolts and compressor.