

REASSEMBLY

Reassembly is in the reverse order of disassembly (See page AC-43).

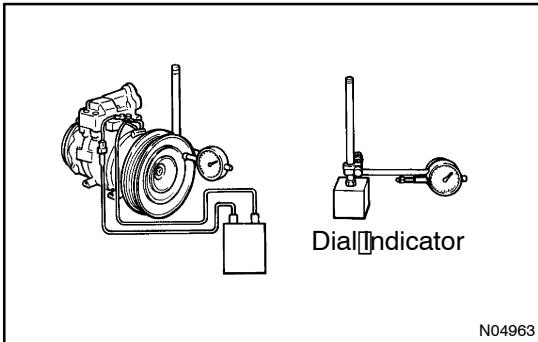

AFTER REASSEMBLY, INSPECT MAGNETIC CLUTCH CLEARANCE

- Set the dial indicator to the pressure plate of the magnetic clutch.
- Connect the magnetic clutch lead wire to the positive (+) terminal of the battery.
- Check the clearance between the pressure plate and rotor when connecting the negative (-) terminal to the battery.

Standard clearance:

0.5 ± 0.15 mm (0.020 ± 0.0059 in.)

If the clearance is not within the standard clearance, adjust the clearance using shims to obtain the standard clearance.

Shim thickness:

0.1 mm (0.004 in.)

0.3 mm (0.012 in.)

0.5 mm (0.020 in.)