

REMOVAL

1. DISCHARGE REFRIGERANT FROM REFRIGERATION SYSTEM

HINT:

At the time of installation, please refer to the following item.

Evacuate air from refrigeration system.

Charge system with refrigerant and inspect for leakage of refrigerant.

Specified amount : 600 ± 50 g (21.16 ± 1.76 oz.)

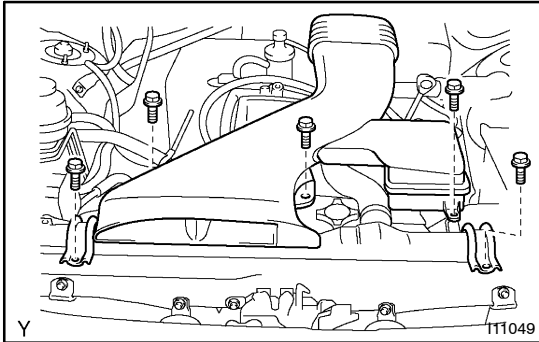

2. REMOVE AIR CLEANER DUCT

Remove the 2 bolts and air cleaner duct.

3. REMOVE ECU OUTLET DUCT

4. REMOVE 2 RADIATOR UPPER SUPPORTS

Remove the 2 bolts and upper supports.

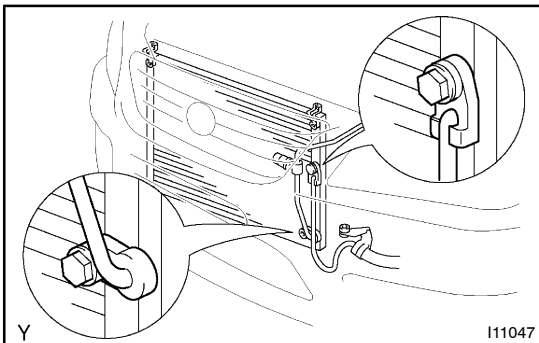

5. DISCONNECT DISCHARGE HOSE AND LIQUID TUBE

Remove the 2 bolts and disconnect the hose and tube.

Torque: 10 N·m (100 kgf·cm, 7 ft·lbf)

NOTICE:

Cap the open fittings immediately to keep moisture or dirt out of the system.

HINT:

At the time of installation, please refer to the following item.

Lubricate 2 new O-rings with compressor oil and install them to the hose and tube.

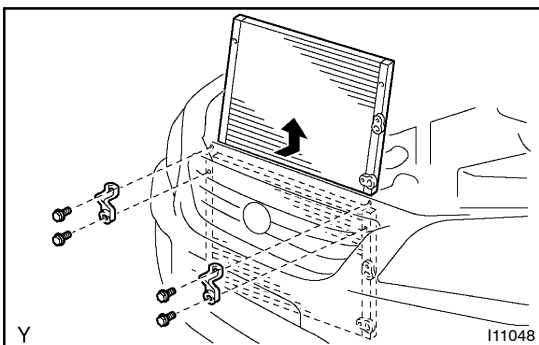

6. REMOVE CONDENSER

(a) Remove the 4 bolts and 2 brackets.

(b) Push the radiator toward engine.

(c) Push the condenser toward radiator and pull it upward.

HINT:

At the time of installation, please refer to the following item.

If condenser is replaced, add compressor oil to the condenser.

Add 40 cc (1.4 fl. oz)

Compressor oil: ND - OIL 8 or equivalent