

DISASSEMBLY

1. REMOVE A/C AMPLIFIER

- (a) Remove the 4 screws.

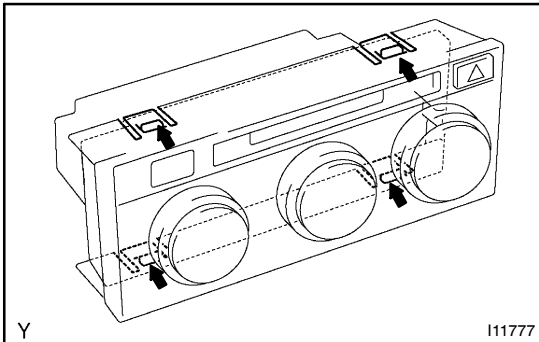

- (b) Using a screwdriver, release the 4 claws and pull out the A/C amplifier.

HINT:

Tape the screwdriver tip before use.

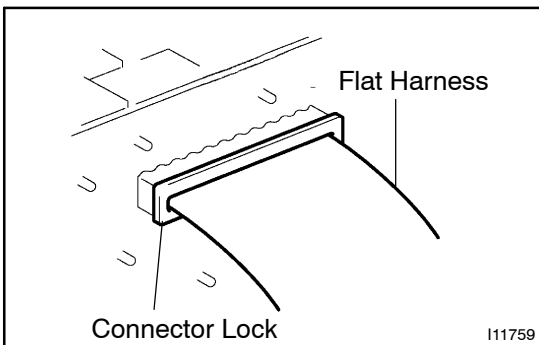

- (c) Release the connector lock and pull out the flat harness.

NOTICE:

Pull the lock of the connector securely toward you and pull off the flexible flat cable.

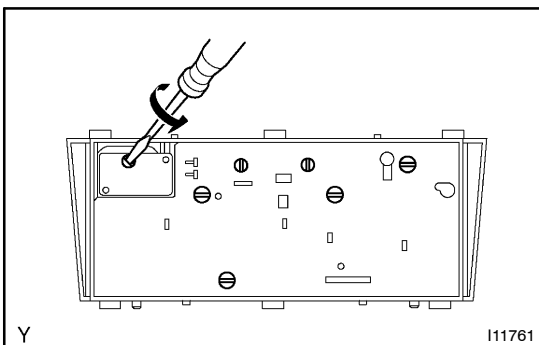

2. REMOVE BULBS

Using a screwdriver, turn the bulbs to the left and pull out the bulbs.

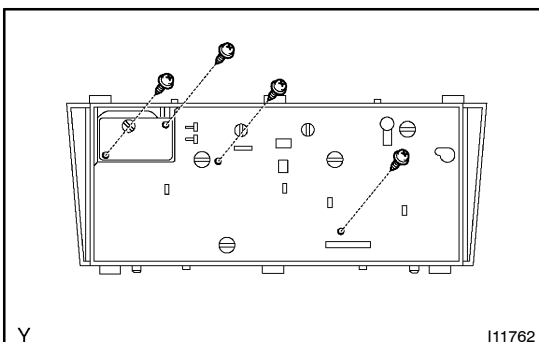

3. REMOVE P/C BOARD

Remove the 4 screws and P/C board.

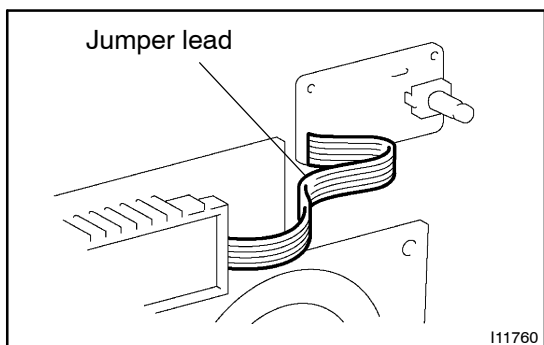
**NOTICE:**

- Do not let any oil, dirt or foreign object on the connecting part of the P/C board.
- When holding the P/C board by hand, hold it at the edge and do not touch the soldered part and connecting part.
- Do not apply unnecessary force to the jumper lead.
- Do not let the accumulated static electricity in an operator apply to the electronic components.
- Do not tumble the LED as this soldered to the P/C board at right angles.

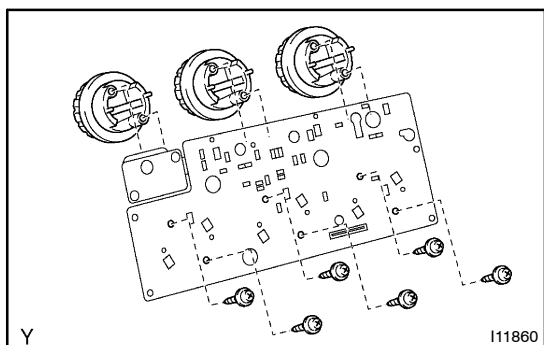
**4. REMOVE DIAL KNOBS**

Remove the 6 screws and dial knobs.

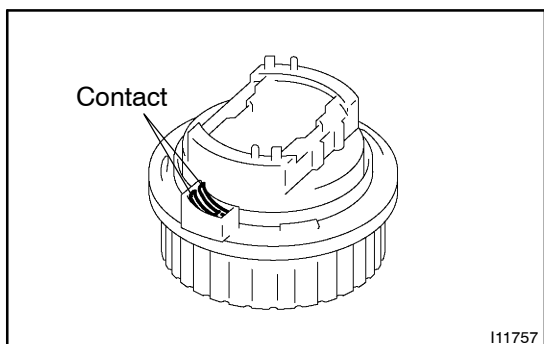
**NOTICE:**

- Do not let any oil, dirt or foreign object attach on the connecting part of the connector.
- Do not deform the contact.
- Be careful not to drop the contact.

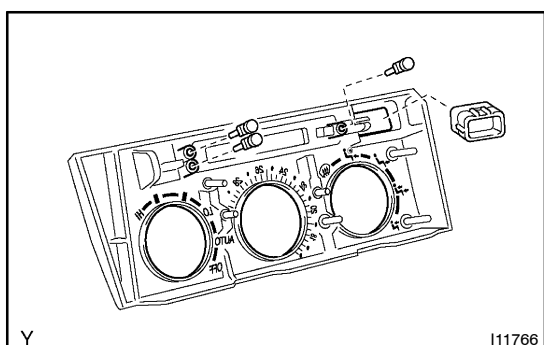
**5. REMOVE KNOB SETS**

Pull out the knob sets.

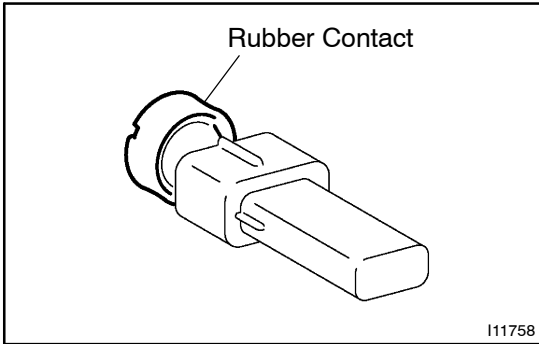

NOTICE:
Do not let any oil, dirt or foreign object attach on the rubber contact part.

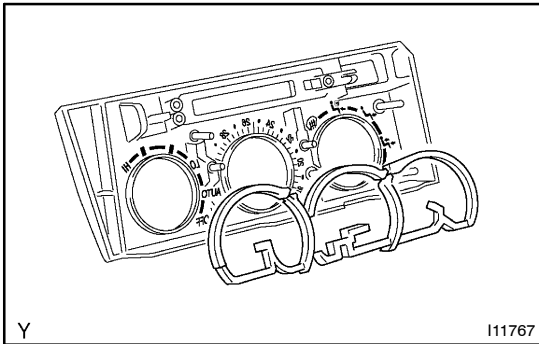

6. REMOVE LENS