

# AUDIO SYSTEM

## DESCRIPTION

BE10X-02

### 1. RADIO WAVE BAND

The radio wave bands used in radio broadcasting are as follows:

Frequency	30 kHz	300 kHz	3 MHz	30 MHz	300 MHz
Designation	LF	MF	HF	VHF	
Radio wave	LW	AM (MW)	SW	FM (UKW)	
Modulation	Amplitude modulation			Frequency modulation	

LF: Low Frequency

MF: Medium Frequency

HF: High Frequency

VHF: Very High Frequency

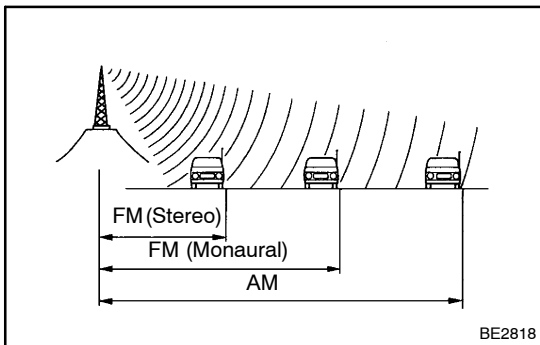

### 2. SERVICE AREA

There are great differences in the size of the service area for AM and FM monaural. Sometimes FM stereo broadcasts cannot be received even though AM can be received very clearly. Not only does FM stereo have the smallest service area, but it also picks up static and other types of interference ("noise") easily.

### 3. RECEPTION PROBLEMS

Besides the problem of static, there are also the problems called "fading", "multipath" and "fade out". These problems are caused not by electrical noise but by the nature of the radio waves themselves.

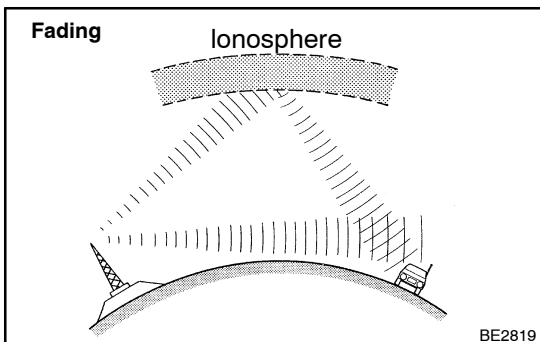

- **Fading**  
Besides electrical interference, AM broadcasts are also susceptible to other types of interference, especially at night. This is because AM radio waves bounce off the ionosphere at night. These radio waves then interfere with the signals from the same transmitter that reach the vehicle's antenna directly. This type of interference is called "fading".

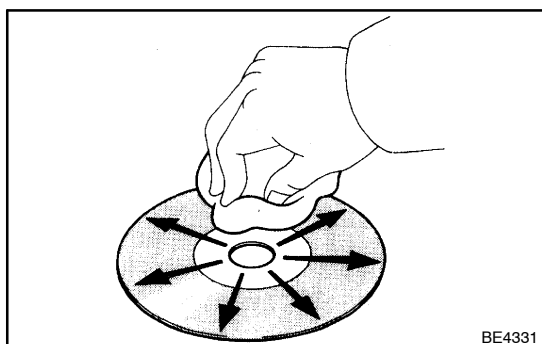
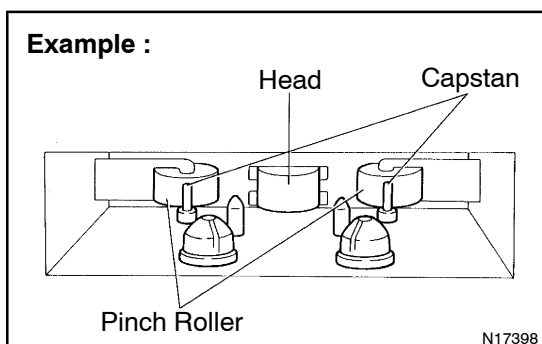
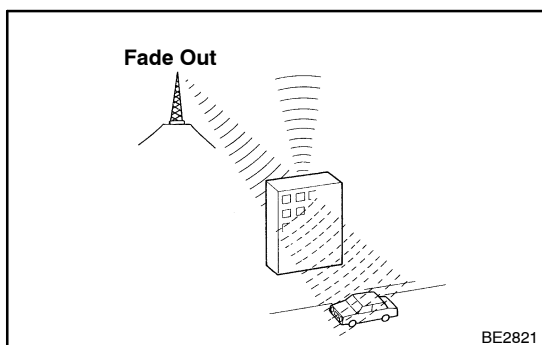
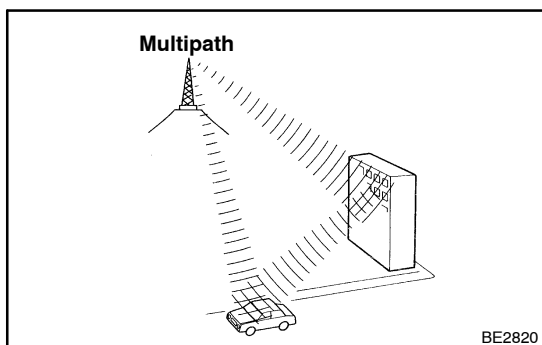

- **Multipath**  
One type of interference caused by the bounce of radio waves off of obstructions is called "multipath". Multipath occurs when a signal from the broadcast transmitter antenna bounces off buildings and mountains and interferes with the signal that is received directly.
- **Fade Out**  
Because FM radio waves are of higher frequencies than AM radio waves, they bounce off buildings, mountains, and other obstructions. For this reason, FM signals often seem to gradually disappear or fade away as the vehicle goes behind a building or other obstruction. This is called "fade out".

#### 4. **Tape Player/Head Cleaning:** **MAINTENANCE**

- (a) Raise the cassette door with your finger. Next, using a pencil or similar object, push in the guide.
- (b) Using a cleaning pen or cotton applicator soaked in cleaner, clean the head surface, pinch rollers and capstans.

#### 5. **CD Player/Disc Cleaning:** **MAINTENANCE**

If the disc gets dirty, clean the disc by wiping the surface from the center to outside in the radial directions with a soft cloth.

#### **NOTICE:**

**Do not use a conventional record cleaner or anti-static preservative.**

## 6. OUTLINE OF AVC-LAN

### (a) What is AVC-LAN?

AVC-LAN is the abbreviation, which stands for Audio Visual Communication-Local Area Network. This is a unified standard co-developed by 6 audio manufactures associated with Toyota Motor Corporation.

The Unified standard covers signals, such as audio signal, visual signal, signal for switch indication and communication signal.

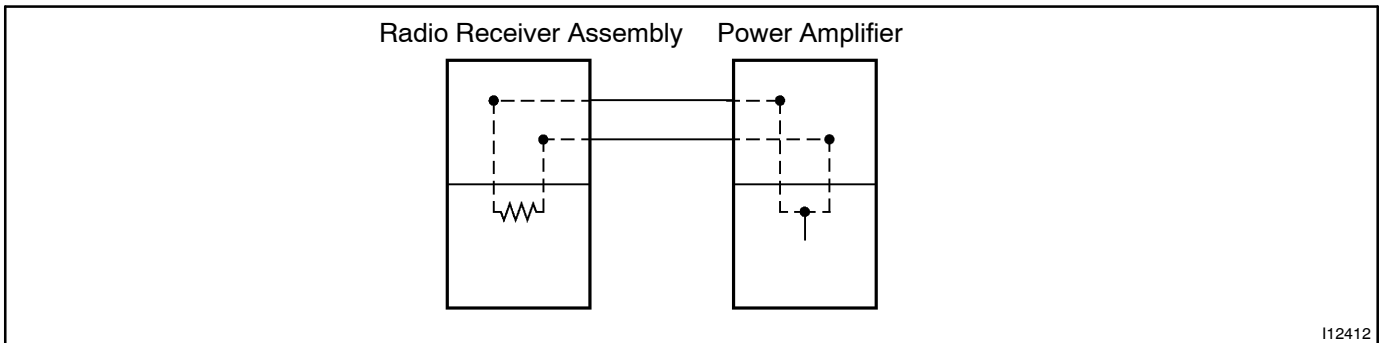

### (b) Objectives

Recently the car audio system has been rapidly developed and functions have been changed drastically. The conventional system has been switched to the multi-media type such as a navigation system. At the same time the level of customers needs to audio system has been upgraded. This lies behind this standardization.

The concrete objectives are explained below.

- (1) When products by different manufactures were combined together, there used to be a case that malfunction occurred such as sound did not come out. This problem has been resolved by standardization of signals.
- (2) Various types of after market products have been able to add or replace freely.
- (3) Because of the above (2), each manufacture has become able to concentrate on developing products in their strongest field. This has enabled many types of products provided inexpensively.
- (4) Conventionally, a new product developed by a manufacture could not be used due to a lack of compatibility with other manufactures products. Because of this new standard, users can enjoy compatible products provided for them timely.

The above descriptions are the objectives to introduce AVC-LAN. By this standardization, development of new products will no longer cause systematic errors. Thus, this is very effective standard for a product in the future.

#### HINT:

- When +B short or GND short is detected in AVC-LAN circuit, communication stops. Accordingly the audio system does not function normally.
- When audio system is not equipped with a navigation system, audio head unit is the master unit. (When audio system is equipped with a navigation system, navigation ECU is the master unit.)
- The car audio system using AVC-LAN circuit has a diagnosis function.
- Each product has its own specified numbers called physical address. Numbers are also allotted to each function in one product, which are called logical address.

**7. DIAGNOSIS FUNCTION**

Error codes over tuner and connected equipment are displayed on the screen of tuner.

(a) Diagnosis start-up

For shifting to diagnosis mode, push "CD" switch 3 times with pressing "1" and "6" of PRESET switch at the same time while the audio power is OFF and ACC is ON.

To exit from diagnosis mode, press "CD" switch for 2 seconds or turn the ignition key OFF. (When "1-190" is displayed, the mode is transferred to LAN check mode.)

(b) LAN check

When starting up the diagnosis mode, the mode turns to LAN check mode, the screen displays the code numbers (physical address) of tuner and connected equipment. Smaller codes are displayed in order, displayed code numbers are switched by operating TUNE "UP" or "DOWN" switch. In LAN check mode, by pressing "5" of PRESET switch for more than 2 secs., diagnosis memory of each equipment can be deleted, when deletion is completed, the mode returns to LAN check mode.

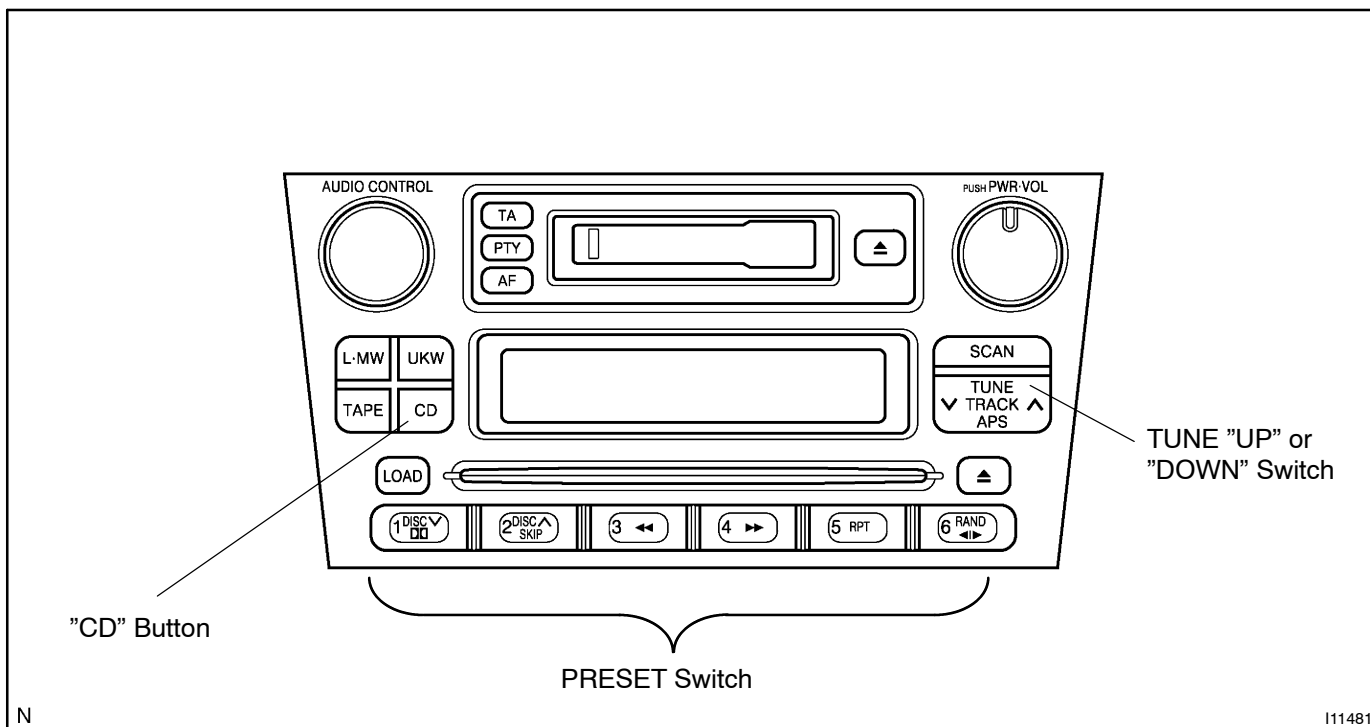

**Code No. (physical address) List**

Code No. (physical address)	Equipment name
190	Radio receiver assembly (Audio head unit)
440	Power amplifier

(c) System check

- When pressing "1" of PRESET switch in LAN check mode, the mode turns to the system check mode, the system performs self diagnosis of connected equipment and displays the results. ("SYS" (showing the system is under detection) is displayed.)
- Perform the operation shown in the following illustration, then read the result of the inspection.

## HINT:

- It sometimes takes approx. 40 secs. till the system inspection is completed.
- The chart below is an example of when diagnosis code "21" appears on the physical address (190) equipment. (ROM error occurs on the radio receiver.)
- The smaller code numbers (physical address) are displayed in order (code No., diagnosis code, support code of diagnosis code (object equipment)).
- When no error is detected in the system, "00" is displayed.
- When an error code is detected, up to 6 codes per one system are displayed. Pressing TUNE "UP" or "DOWN" switches the display.
- In the system check mode, when pressing "6" of PRESET switch the mode returns to LAN check mode.

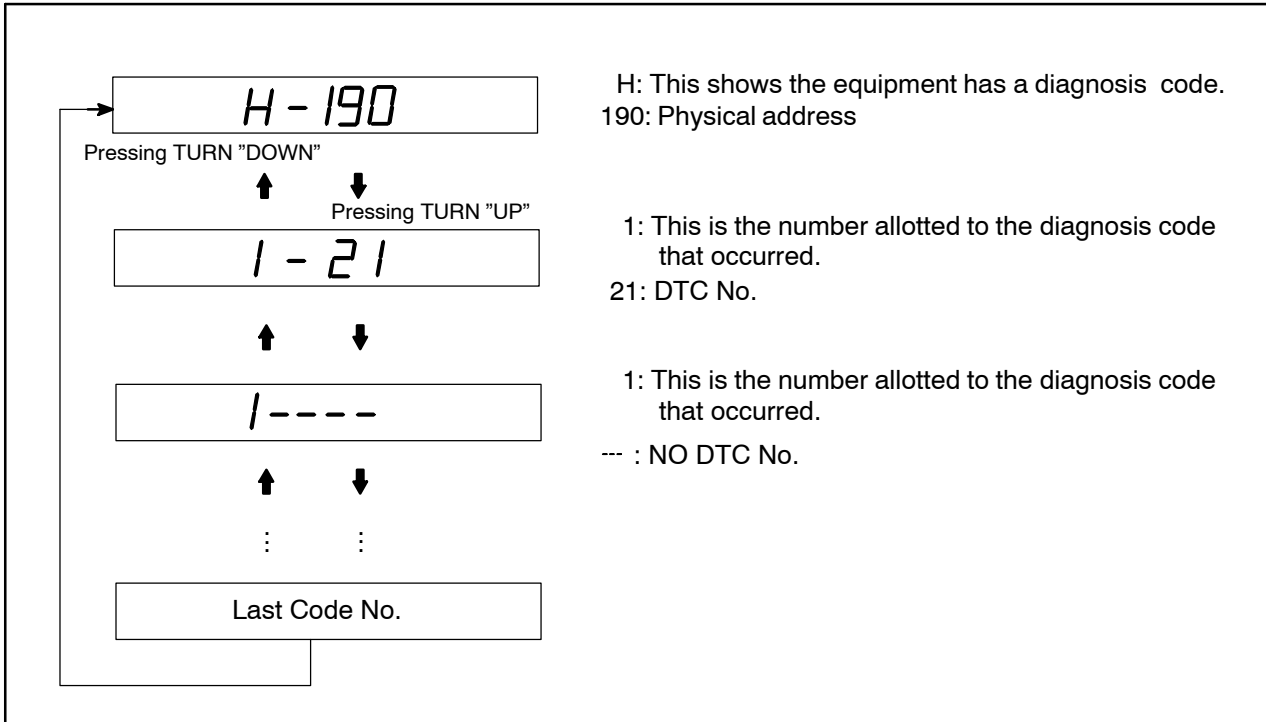

## (d) Diagnosis memory

- (1) In LAN check mode, when pressing "2" of PRESET switch the mode turns to the diagnosis memory mode. ("CODE" is displayed.)

The results of self diagnosis performed over tuner and connected equipment are memorized and displayed.

- (2) Perform the operation shown in the following illustration, then read the result of the inspection.

## HINT:

- The smaller code numbers (physical address) are displayed in order (code No. , periodic communication number when error occurs, diagnosis code, and support code of diagnosis code (object equipment)).
- When no error is detected in the system, "00" is displayed. When an error code is detected, up to 6 codes per one system are displayed. Pressing TUNE "UP" or "DOWN" switches the display. Each diagnosis code is same as code in the system check mode.
- When pressing "6" of PRESET switch, the mode returns to LAN check mode.
- The following illustration below is an example of when diagnosis code "D1" appears on the code (190) and (240 or 360) equipment. (Communication error occurs between the radio receiver and CD changer.)

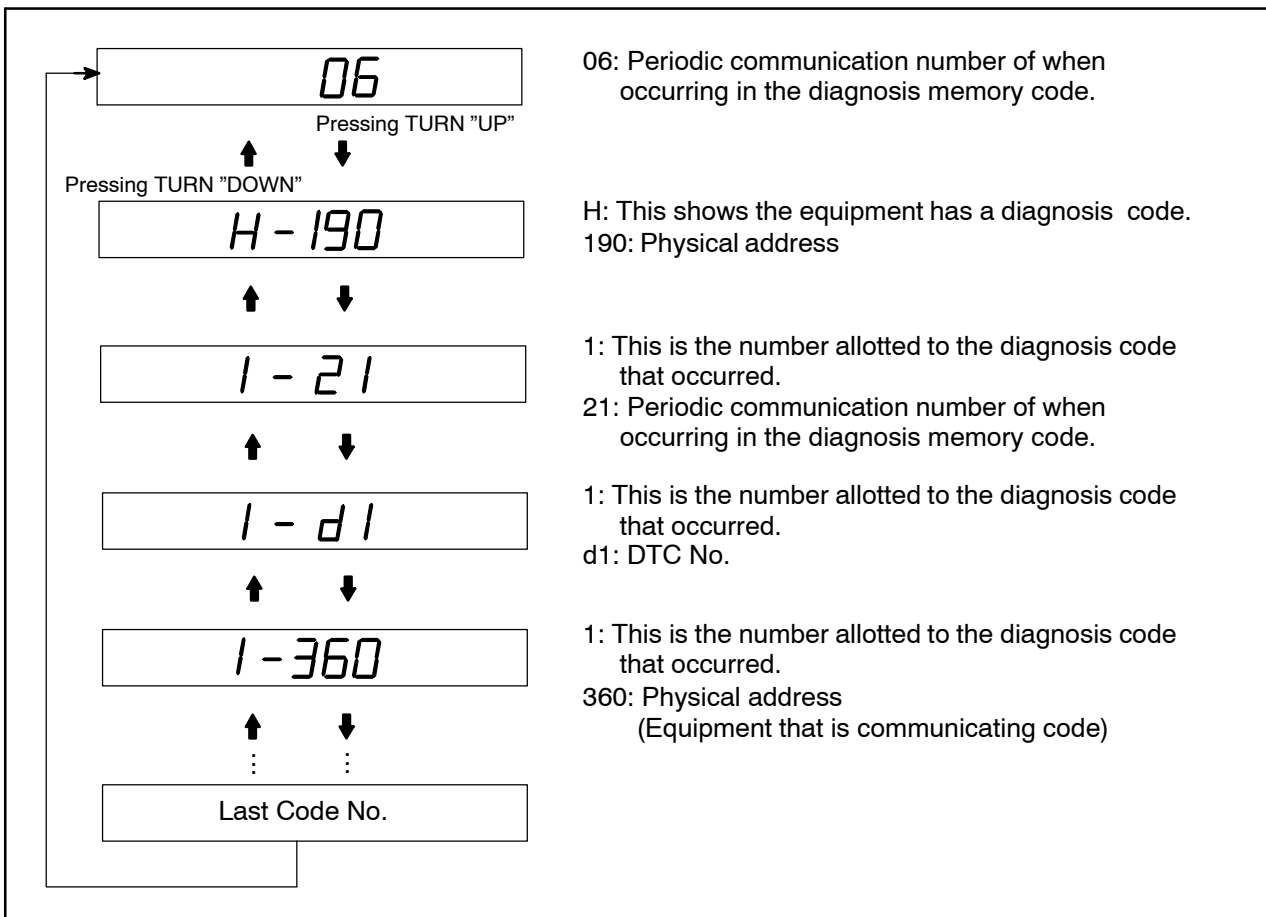

## (e) Diagnosis memory clear

- (1) After error is fixed, start up the diagnosis mode.
- (2) Continue pressing preset switch "5" for 2 secs. (CLr is displayed.)
- (3) Press the preset switch "2" and transfer to the diagnosis memory mode and check that the normal code (00) is output.

**8. DIAGNOSIS CODE LIST**

- If there is "O" in the column of system check, an error can be detected when the mode is switched to the system check mode.
- If there is "O" in the column of diagnosis mode, each unit is monitoring whether or not it has failure. In case of detecting failure, it memorizes DTC.

Parts Name	DTC	Diagnosis item	Diagnosis content	Countermeasure and inspected parts	System Check	Diagnosis memory
Head Unit (190)	42	FM tuner error	There is an error in FM tuner.	Radio receiver check.	X	○
	50	Cassette error	There is an error in cassette deck.		X	○
	51	Cassette eject error	Cassette can not be ejected from Head Unit.		X	○
	D1	Transmitter error	Communication with the equipment that is communicating has failed successively.	Radio receiver check. Wire harness and connector check.	○	○
	D2	Periodic communication no response	Error in periodic communication.	● Wire harness and connector	X	○
	FF	Diagnosis no response	Result of diagnosis is not issued from start to finish.	Radio receiver check.	○	X
AMP (440)	D1	Transmitter error	Communication with the equipment that is communicating has failed successively.	Stereo component amplifier check.	○	○
	D4	Periodic communication error	Connection confirmation has not come from the equipment that is communicating	● Radio receiver check. ● Wire harness check.	X	○