

DISASSEMBLY

1. REMOVE INSIDE HANDLE BEZEL

- (a) Using a screwdriver, open the screw cap.

HINT:

Tape the screwdriver tip before use.

- (b) Remove the screw.

- (c) Using a screwdriver, remove the inside handle bezel as shown in the illustration.

HINT:

Tape the screwdriver tip before use.

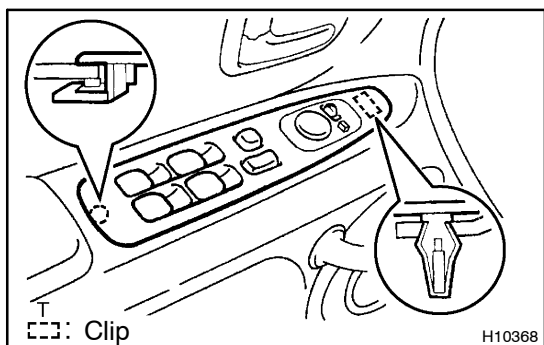

2. REMOVE POWER WINDOW SWITCH

- (a) Using a screwdriver, remove the power window switch.

HINT:

Tape the screwdriver tip before use.

- (b) Disconnect the connectors.

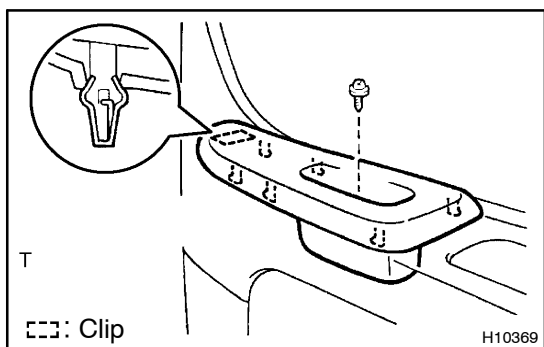

3. REMOVE FRONT ARMREST

- (a) Remove the screw.

- (b) Using a screwdriver, remove the front armrest as shown in the illustration.

HINT:

Tape the screwdriver tip before use.

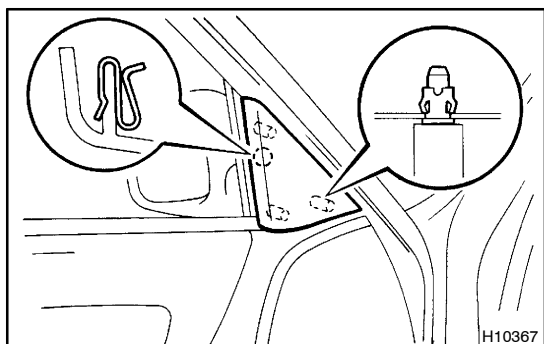

4. REMOVE LOWER FRAME BRACKET GARNISH

Remove the lower frame bracket garnish.

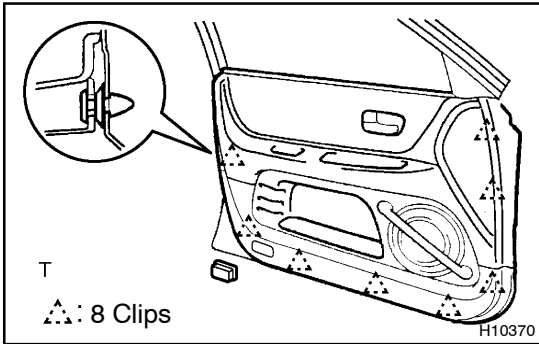
**5. REMOVE DOOR TRIM**

- (a) Using a screwdriver, remove the courtesy light, then disconnect the connector.

HINT:

Tape the screwdriver tip before use.

- (b) Using a screwdriver, disengage the clips, then pull the trim upward to remove it.

HINT:

Tape the screwdriver tip before use.

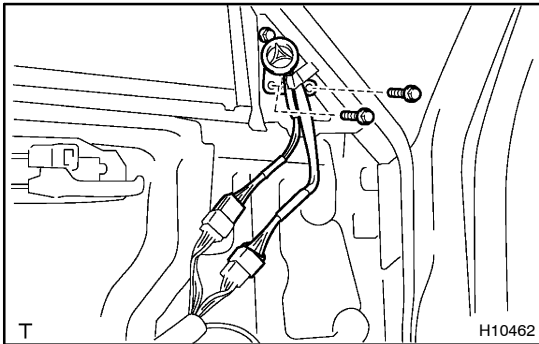
**6. w/ Front No.2 speaker:****REMOVE FRONT NO.2 SPEAKER**

- (a) Disconnect the 2 connectors.
(b) Remove the 2 bolts and front No.2 speaker.

7. REMOVE OUTSIDE REAR VIEW MIRROR

- (a) Disconnect the connector.
(b) w/ Front No.2 speaker:
Remove the bolt and outside rear view mirror.
(c) w/o Front No.2 speaker:
Remove the 3 bolts and outside rear view mirror.

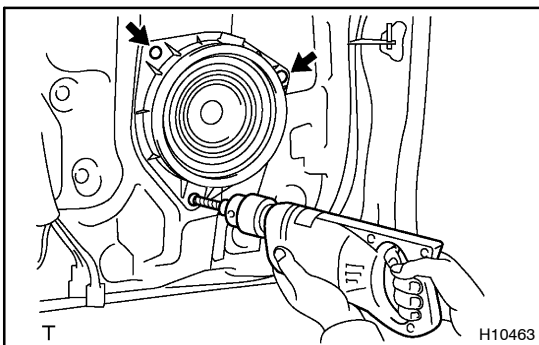
**8. REMOVE FRONT NO.1 SPEAKER**

- (a) Disconnect the connector.
(b) Using a drill of less than $\varnothing 4$ mm (0.16 in.), drill out the rivet heads and remove the speaker.
(c) Gently and vertically put the drill to the rivet, and cut the rivet flanges.

NOTICE:

- **Prizing the hole with a drill can lead to damage to the rivet hole or breaking the drill.**
 - **Take care as the cut rivet is hot.**
- (d) Even if flange is taken off, continue drilling and push out remaining fragments with the drill.
(e) Using a vacuum cleaner, remove the drilled rivet and their dust from the inside of the door.

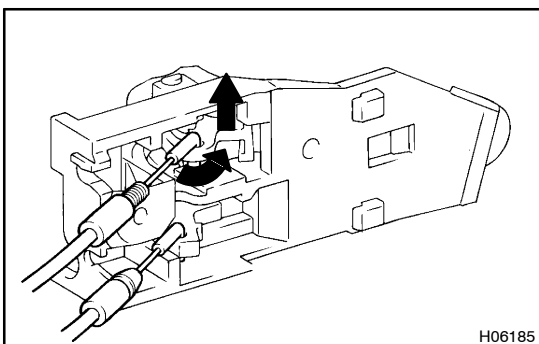
**9. REMOVE INSIDE HANDLE**

Remove the screw and inside handle, disconnect the 2 cables from the inside handle.

BODY - FRONT DOOR

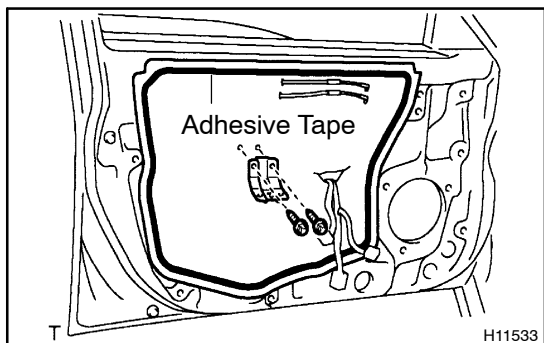
**10. REMOVE SERVICE HOLE COVER**

- (a) Remove the 2 screws and door trim bracket.
- (b) Remove the service hole cover.

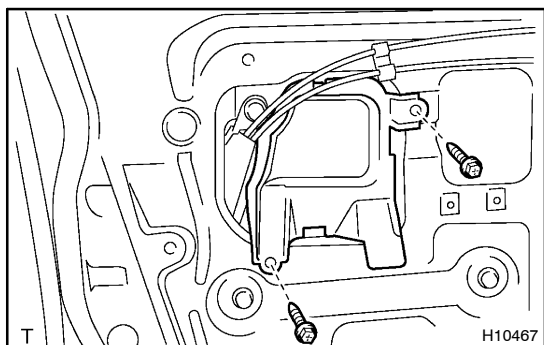
**11. w/o Double locking:****REMOVE NO.2 SERVICE HOLE COVER**

Remove the 2 screws and No.2 service hole cover.

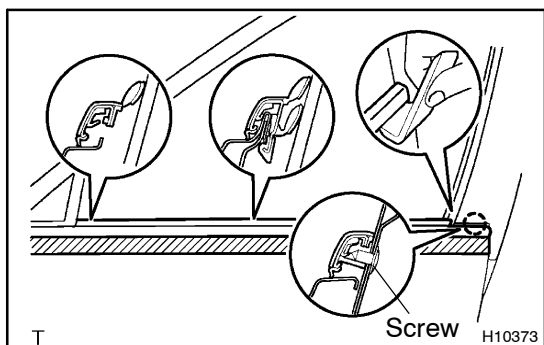
**12. REMOVE FRONT DOOR BELT MOULDING**

- (a) Remove a screw.
- (b) Apply protective tape to the outer surface as shown in the illustration, to keep the surface from being scratched.
- (c) Using a moulding remover, remove the front door belt moulding as shown in the illustration.

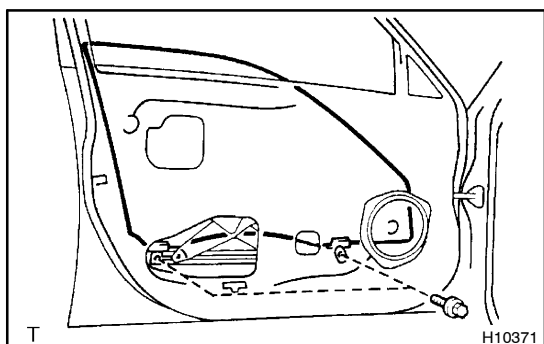
**13. REMOVE DOOR GLASS****HINT:**

Insert a shop rag inside the door panel to prevent scratching the glass.

- (a) Open the door glass until the bolts appear in the service hole.
- (b) Remove the 2 bolts and door glass.

NOTICE:

Do not damage the door glass.

HINT:

Pull the glass upward to remove it.

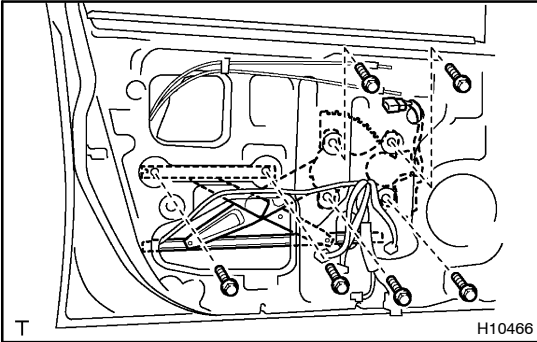
**14. REMOVE WINDOW REGULATOR**

- (a) Disconnect the connector and disengage the clamps.
- (b) Remove the 6 bolts and window regulator.

15. REMOVE DOOR GLASS RUN**16. REMOVE REAR LOWER FRAME**

Remove the bolt and rear lower frame.

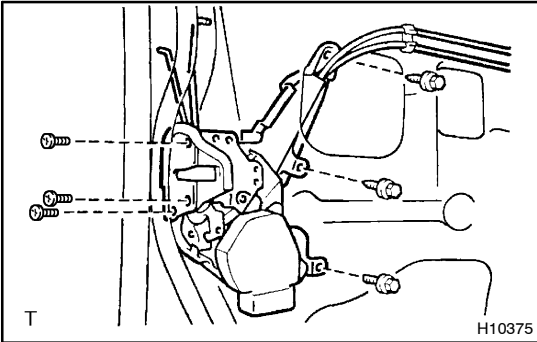
**17. REMOVE DOOR LOCK**

- (a) Disconnect the 2 links from the outside handle and key cylinder.
- (b) Remove the bolt and 2 screws.
- (c) Using a torx socket wrench, remove the 3 torx screws and door lock.

Torx socket wrench: T30 (Part No. 09042-00010 or locally manufactured tool)

- (d) Disconnect the connector.

HINT:

Remove the door lock through the service hole.

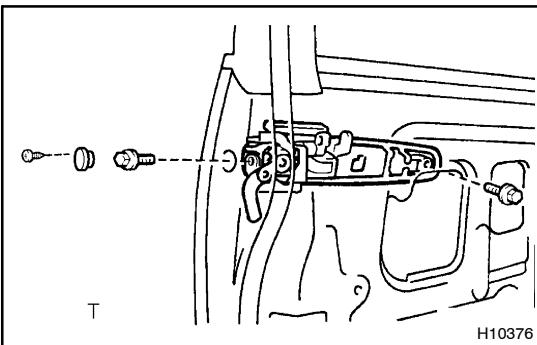
**18. REMOVE OUTSIDE HANDLE AND KEY CYLINDER**

- (a) Remove the screw and hole cover.
- (b) Remove the 2 bolts and outside handle with the key cylinder.
- (c) Remove the retainer from the outside handle.
- (d) Remove the bolt, key cylinder and protector from the outside handle.

19. REMOVE CUSHIONS