

## REMOVAL

### 1. REMOVE ENDS OF MOULDING

- (a) Apply protective tape to the outer surface as shown in the illustration to keep the surface from being scratched.
- (b) Using a heat light heat the moulding to 20 – 30 °C (68 – 86 °F).

#### NOTICE:

**Do not heat the moulding excessively.**

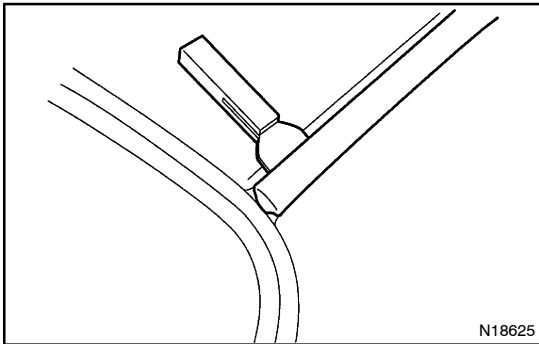

- (c) Using a scraper, pull off the roof drip side finish moulding from the front end and rear end.

#### HINT:

Tape the scraper tip before use.

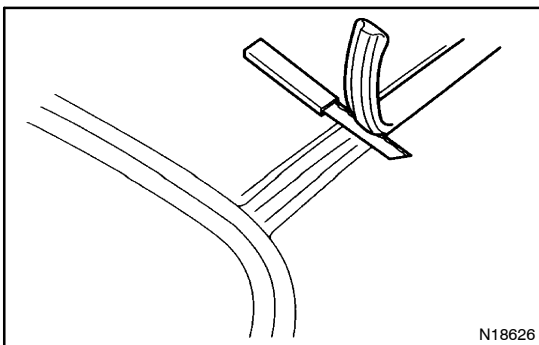

### 2. REMOVE MOULDING AND ADHESIVE

- (a) Pull off the moulding by cutting the adhesive with a knife at the front and rear ends.
- (b) Remove the moulding.

#### NOTICE:

**Do not damage the body with the knife.**