

INSTALLATION

1. CLEAN CONTACT SURFACE OF BODY

- (a) Using a heat light, heat the moulding surface to 40 – 60 °C (104 – 140 °F).

NOTICE:

Do not heat the body excessively.

- (b) Using a knife, cut away any rough areas on the body.

NOTICE:

Be careful not to damage the body.

- (c) Wipe off stains with cleaner.

2. If reusing the moulding:

CLEAN MOULDING

- (a) Using a heat light, heat the moulding surface to 20 – 30 °C (68 – 86 °F).

NOTICE:

Do not heat the moulding excessively.

- (b) Using a knife, cut the remaining adhesive from the moulding.

NOTICE:

Be careful not to damage the moulding.

- (c) Wipe off stains with cleaner.

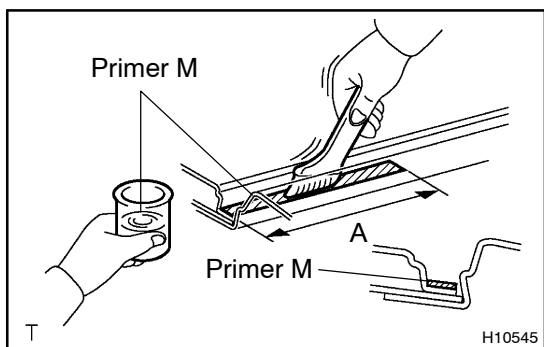

3. COAT CONTACT SURFACE OF BODY WITH PRIMER "M"

Using a brush, coat the contact surface on the body with Primer M as shown in the illustration.

Front end:

A: 40 mm (1.57 in.)

Rear end:

A: 35 mm (1.38 in.)

NOTICE:

- **Let the primer coating dry for 3 minutes or more.**
- **Do not coat the adhesive.**
- **Do not keep any of the opened Primer M for later use.**

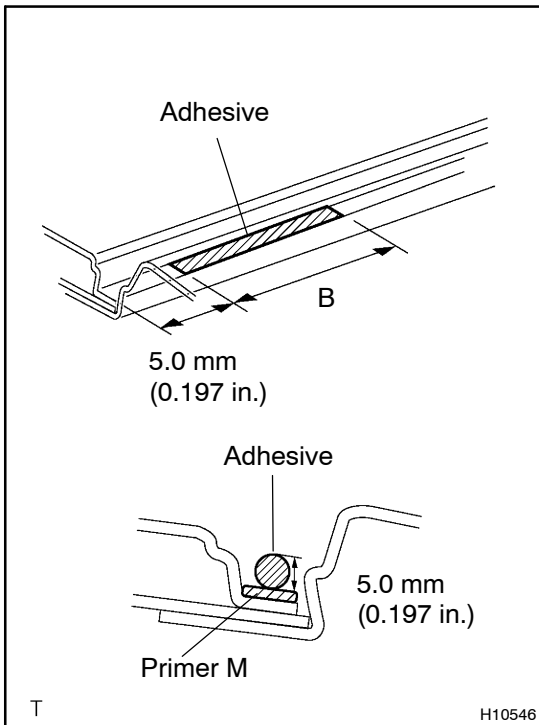

4. APPLY ADHESIVE

(a) Cut off the tip of the cartridge nozzle.

Part No. 08850-00801 or equivalent

HINT:

After cutting off the tip, use all adhesive within the time described in the chart below.

Temperature	Tackfree time
35 °C (95 °F)	15 minutes
20 °C (68 °F)	100 minutes
5 °C (41 °F)	8 hours

(b) Load the cartridge into the sealer gun.

(c) Apply adhesive to the hatched area in the illustration for both front and rear of the vehicle.

Front end:

B: 30 mm (1.18 in.)

Rear end:

B: 25 mm (0.98 in.)

HINT:

When removing the moulding, apply adhesive well to the part where the body sealer is removed.

5. INSTALL MOULDING

Push the moulding to the body.

NOTICE:

- **Make sure that the body and moulding are heated to the proper temperature.**
- **Do not depress the adhesive coated parrs excessively but just hold them down with your thumb.**
- **Scrape off any overflowing adhesive with a plastic spatula and clean the surface with a dry rag.**
- **Take care not to drive the vehicle during the time described in the chart below.**

Temperature	Minimum time prior to driving the vehicle
35 °C (95 °F)	1.5 hours
20 °C (68 °F)	5 hours
5 °C (41 °F)	24 hours