

## INSPECTION

### CAUTION:

Replace the seat belt assembly (outer belt, inner belt, bolts, nuts or sill-bar) if it has been used in a severe impact. The entire assembly should be replaced even if damage is not obvious.

### 1. RUNNING TEST (IN SAFE AREA)

- (a) Fasten the front seat belts.
- (b) Drive the car at 10 mph (16 km/h) and slam on the brakes. Check that the belt locks and cannot be extended at this time.

### HINT:

Conduct this test in a safe area. If the belt does not lock, remove the belt mechanism assembly and conduct the following static check. Also, whenever installing a new belt assembly, verify the proper operation before installation.

### 2. Driver's Seat Belt (ELR): STATIC TEST

- (a) Make sure that the belt locks when pulled out quickly.
- (b) Remove the locking retractor assembly.
- (c) Tilt the retractor slowly.

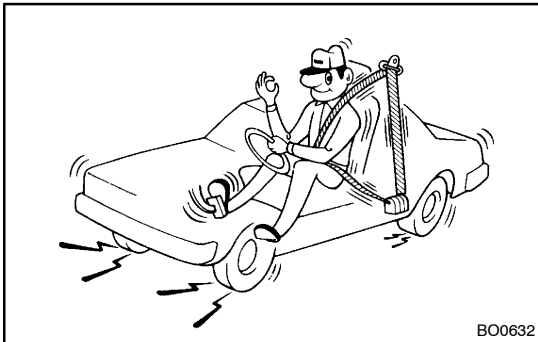

BO0632

- (d) Make sure that the belt can be pulled out at a tilt of 15 degrees or less, and cannot be pulled out over 45 degrees of tilt.

If a problem is found, replace the assembly.

### 3. Except Driver's Seat Belt (ELR/ALR): STATIC TEST

- (a) Make sure that the belt locks when pulled out quickly.
- (b) Remove the locking retractor assembly.
- (c) Pull out the whole belt and measure the length of the whole belt.

Then retract the belt slightly and pull it out again.

- (d) Make sure that the belt cannot be extended further.

If a problem is found, replace the assembly.

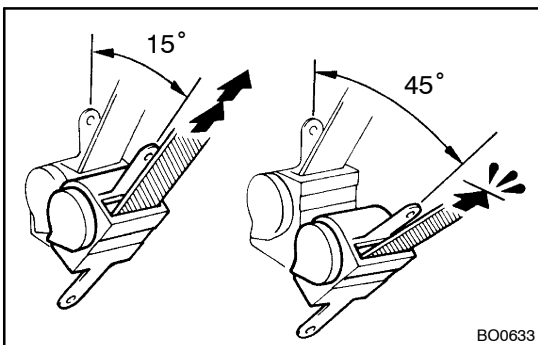

BO0633

## BODY - SEAT BELT

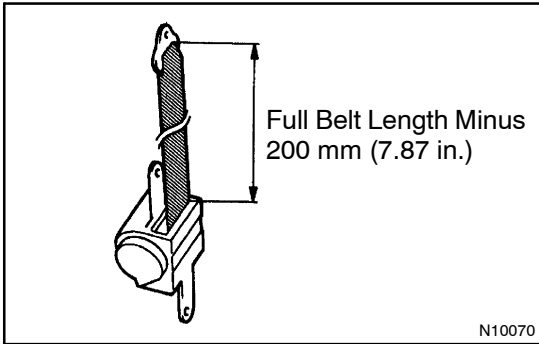

- (e) Retract the whole belt, then pull out the belt until 200 mm (7.87 in.) of belt remains retracted.
- (f) Tilt the retractor slowly.

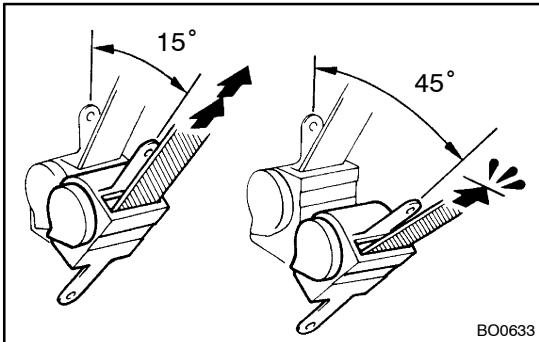

- (g) Make sure that the belt can be pulled out at a tilt of 15 degrees or less, and cannot be pulled out at over 45 degrees of tilt.

If a problem is found, replace the assembly.