

REASSEMBLY

1. PLACE DRIVE END FRAME ON PULLEY
2. INSTALL ROTOR TO DRIVE END FRAME
3. INSTALL RECTIFIER END FRAME

(a) Place the alternator washer on the rotor.

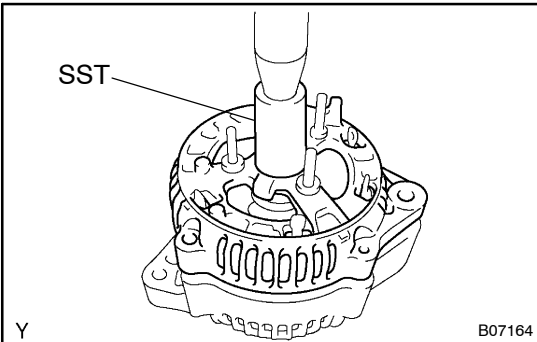

(b) Using SST and a press, slowly press in the rectifier end frame.

SST 09820-00030

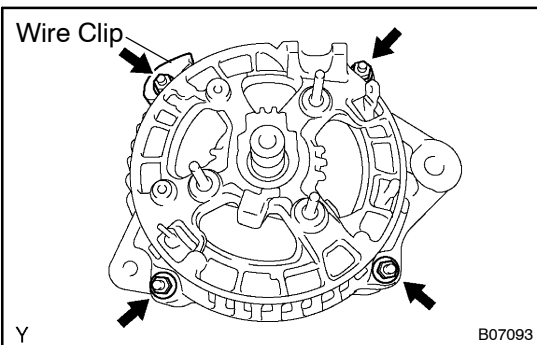

(c) Install the wire clip and 4 nuts.

Torque:

4.5 N·m (46 kgf·cm, 40 in·lbf) without wire clip

5.4 N·m (55 kgf·cm, 48 in·lbf) with wire clip

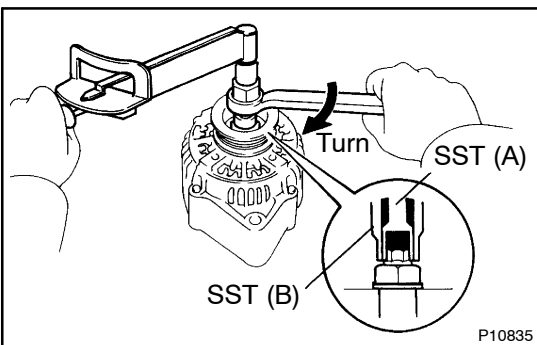

4. INSTALL PULLEY

(a) Install the pulley to the rotor shaft by tightening the pulley nut by hand.

(b) Hold SST (A) with a torque wrench, and tighten SST (B) clockwise to the specified torque.

SST 09820-63010

Torque: 39 N·m (400 kgf·cm, 29 ft·lbf)

(c) Check that SST (A) is secured to the pulley shaft.

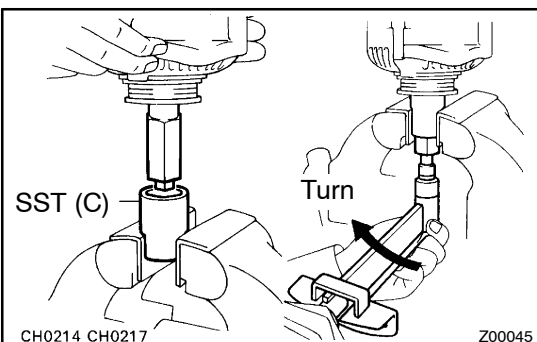

(d) Mount SST (C) in a vise.

(e) Insert SST (B) into SST (C), and attach the pulley nut to SST (C).

(f) To torque the pulley nut, turn SST (A) in the direction shown in the illustration.

Torque: 110.5 N·m (1,125 kgf·cm, 81 ft·lbf)

(g) Remove the alternator from SST (C).

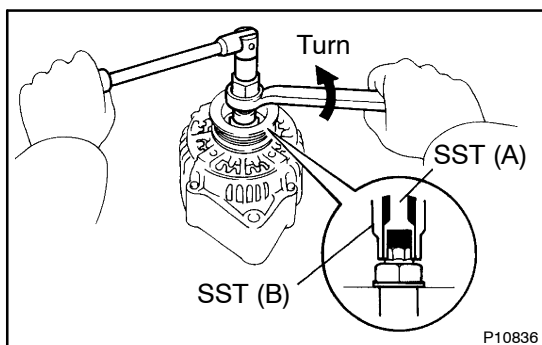

- (h) Turn SST (B), and remove SST (A and B).

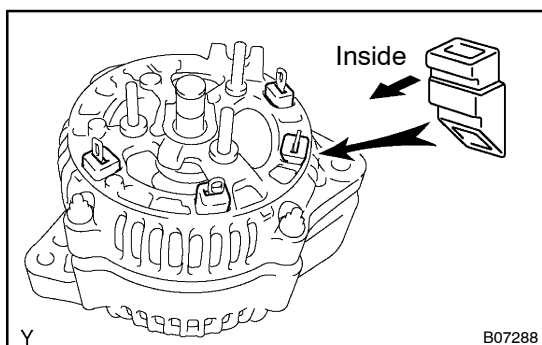

5. INSTALL RECTIFIER HOLDER

- (a) Install the 4 rubber insulators on the lead wires.

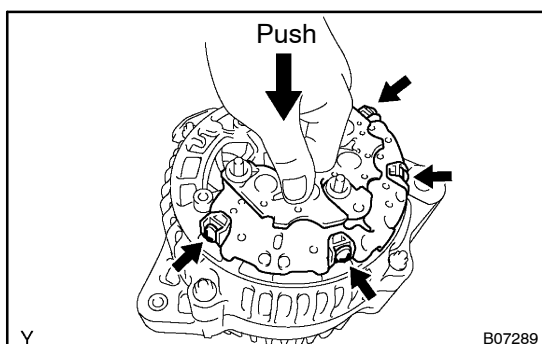

- (b) Install the rectifier holder while pushing it with the 4 screws.

Torque: 2.9 N·m (30 kgf·cm, 26 in·lbf)

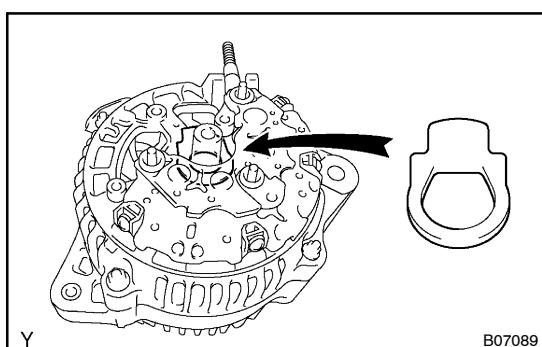

6. INSTALL IC REGULATOR AND BRUSH HOLDER

- (a) Place the seal plate on the rectifier end frame.

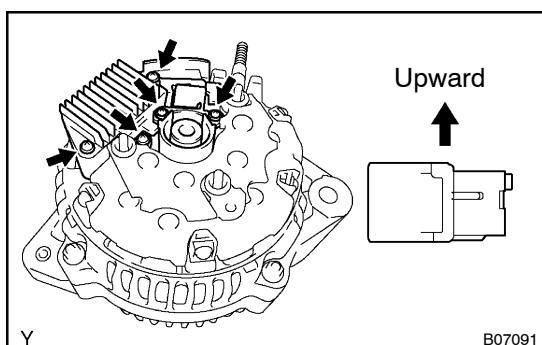

- (b) Place the IC regulator and brush holder on the rectifier end frame.

NOTICE:

Be careful of the holder installation direction.

- (c) Install the 5 screws.

Torque: 2.0 N·m (20 kgf·cm, 18 in·lbf)

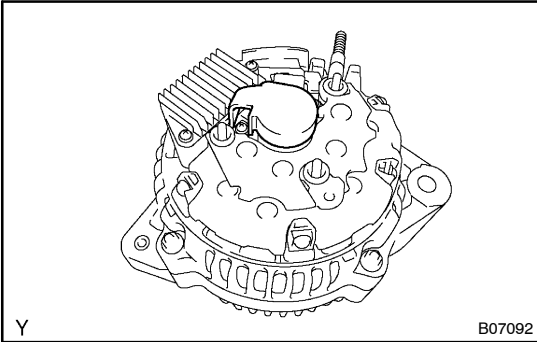

- (d) Place the brush holder cover on the brush holder.

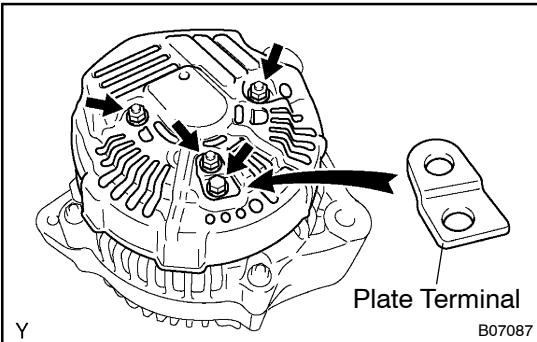

7. INSTALL REAR END COVER

- (a) Install the end cover and plate terminal with the bolt and 3 nuts.

Torque:

4.4 N·m (45 kgf·cm, 39 in.·lbf) for nut

3.9 N·m (39 kgf·cm, 35 in.·lbf) for bolt

- (b) Install the terminal insulator with the nut.

Torque: 4.1 N·m (41.5 kgf·cm, 36.3 in.·lbf)

8. CHECK THAT ROTOR ROTATES SMOOTHLY