

<b>DTC</b>	<b>C1224 / 44</b>	<b>NE Signal Circuit</b>
------------	-------------------	--------------------------

## CIRCUIT DESCRIPTION

The ABS & TRC ECU receives engine revolution speed signals (NE signals) from the engine and ECT ECU.

DTC No.	DTC Detecting Condition	Trouble Area
C1224 / 44	When any of the following 1. through 2. is detected: 1. At vehicle speed of 30 km/h (19 mph) or more, and when data receiving from the engine and ECT ECU is in normal condition, and open or short circuit for engine revolution signal circuit continues for 10 sec. or more. 2. While TRC is operating and when open or short circuit for engine revolution signal circuit continues for 0.24 sec. or more.	<ul style="list-style-type: none"> <li>•NEO circuit</li> <li>•Engine and ECT ECU</li> <li>•ABS &amp; TRC ECU</li> </ul>

Fail safe function:

If any trouble occurs in the NE signal circuit, the ECU prohibits TRC controls.

## WIRING DIAGRAM

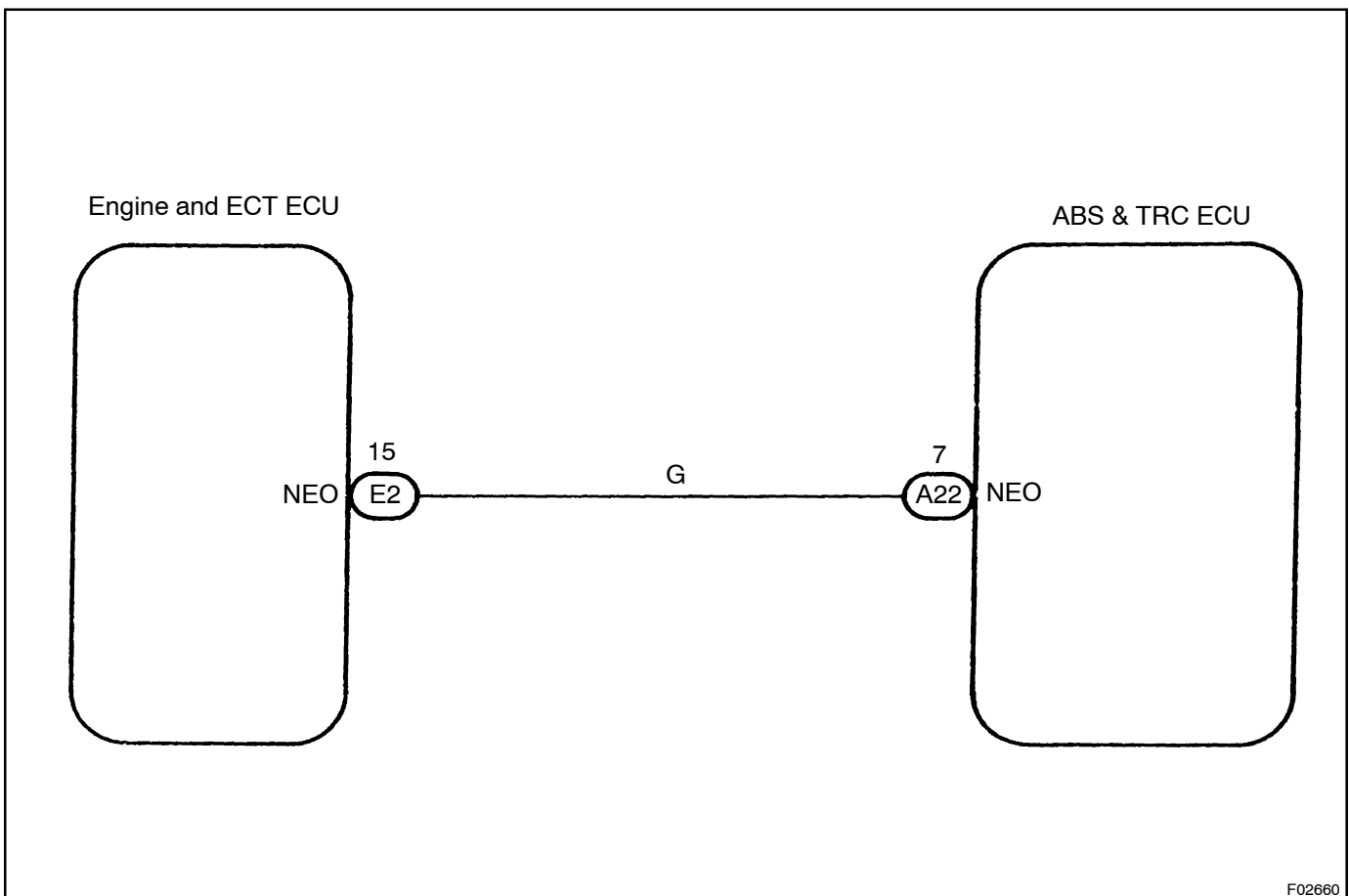

F02660

## INSPECTION PROCEDURE

- 1 Check for open and short circuit in harness and connector between terminals NEO of ABS & TRC ECU and terminal NEO of engine and ECT ECU (See page IN-32).

NG

Repair or replace harness and connector.

OK

- 2 Check voltage between terminals NEO of ABS & TRC ECU and body ground.

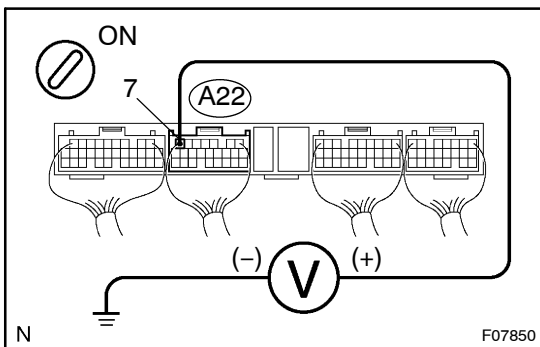
**PREPARATION:**

- (a) Remove the ABS & TRC ECU with connectors still connected.  
 (b) Turn the ignition switch ON.

**CHECK:**

Measure voltage between terminal NEO (A22 - 7) of ABS & TRC ECU and body ground for the engine conditions below.

**OK:**

Engine condition	Voltage
OFF (IG ON)	3 - 6 V or below 1 V
ON (Idling)	3 - 6 V ↔ below 1 V (Pulse)

(Reference)

3 - 6 V

Below 1 V

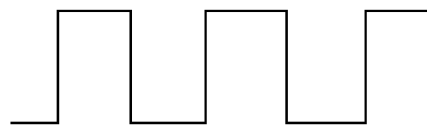

F03007

NG

Check and replace ABS &amp; TRC ECU or engine and ECT ECU.

OK

If the same codes is still output after the DTC is deleted, check the contact condition of each connection.