

Tc Terminal Circuit

CIRCUIT DESCRIPTION

Connecting between terminals Tc and E₁ of the check connector or Tc and CG of the DLC3 causes the ECU to display the DTC by blinking the ABS warning light and TRC OFF indicator light.

WIRING DIAGRAM

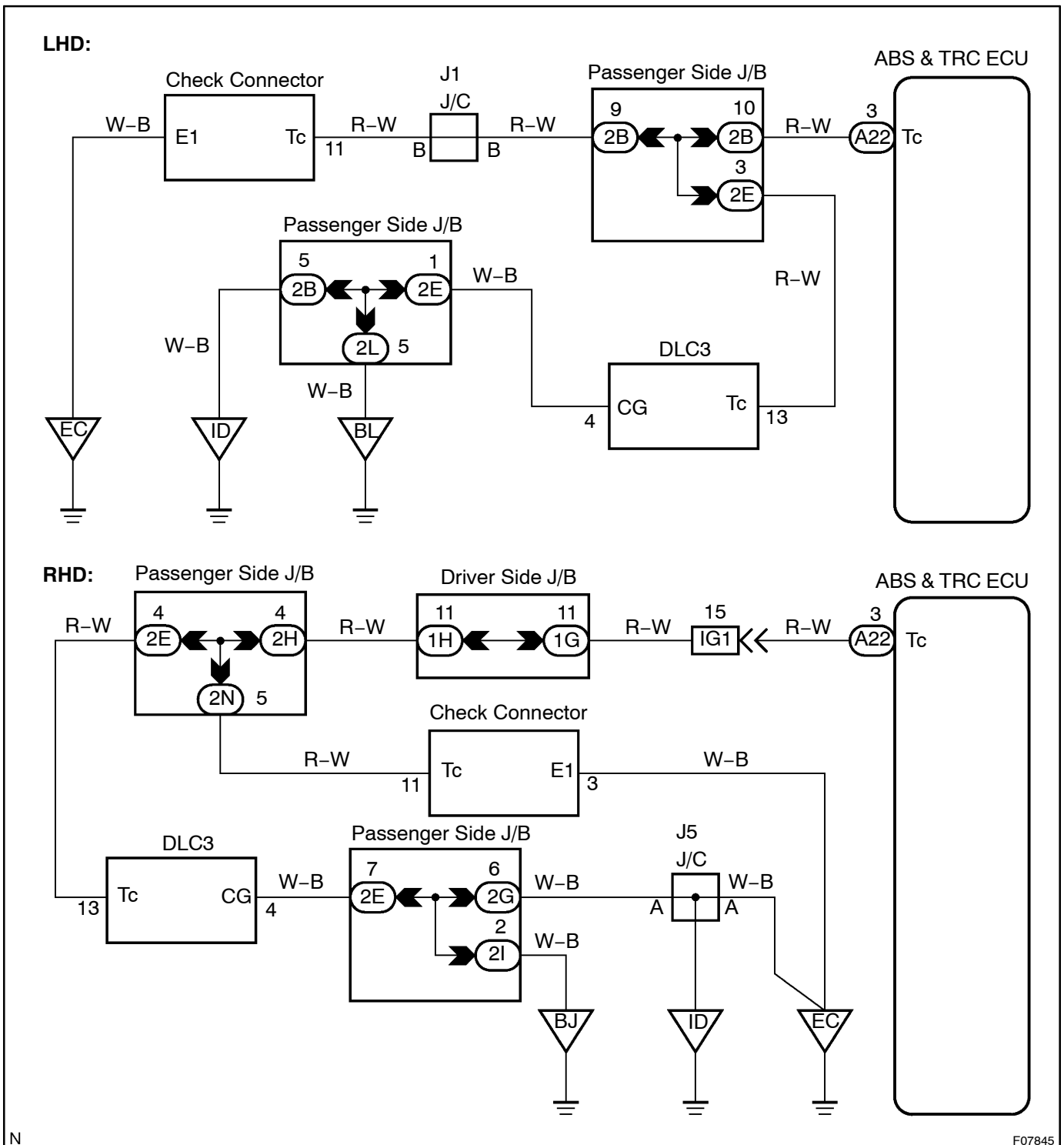

N

F07845

INSPECTION PROCEDURE

- 1 Check voltage between terminals Tc and E₁ of check connector or Tc and CG of DLC3.

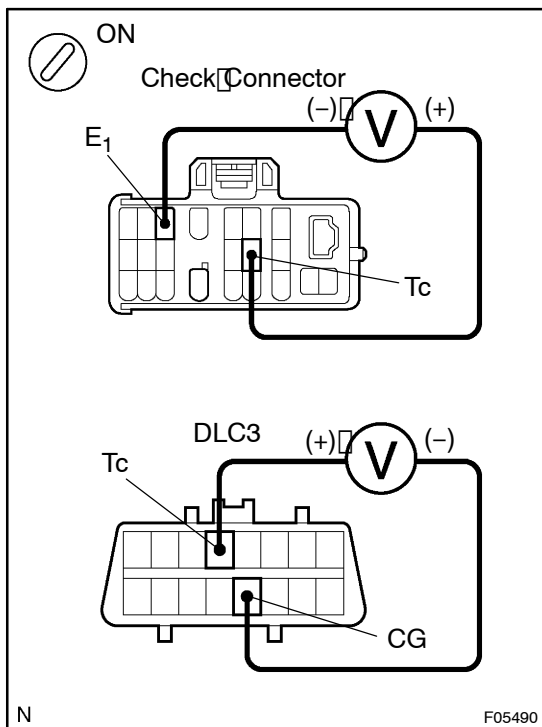
**CHECK:**

- (a) Turn the ignition switch ON.
 (b) Measure voltage between terminals Tc and E₁ of check connector or Tc and CG of DLC3.

OK:

Voltage: 10 - 14 V

OK

If ABS warning light does not blink even after Tc and E₁ or Tc and CG have been connected, the ECU may be defective.

NG

- 2 Check for open and short circuit in harness and connector between ABS & TRC ECU and check connector of DLC3, check connector of DLC3 and body ground (See page IN-32).

NG

Repair or replace harness or connector.

OK

Check and replace ABS & TRC ECU.