

## PRE-CHECK

### 1. SRS WARNING LIGHT CHECK

- (a) Turn the ignition switch to the ACC or ON position and check that the SRS warning light lights up.
- (b) Check that the SRS warning light goes out after approx. 6 seconds.

#### HINT:

- When the ignition switch is at ACC or ON and the SRS warning light remains on or flashes, the airbag sensor assembly has detected a malfunction code.
- If, after approx. 6 seconds have elapsed, the SRS warning light sometimes lights up or the SRS warning light lights up even when the ignition switch is OFF, a short in the SRS warning light circuit can be considered likely. Proceed to "SRS warning light circuit malfunction" on page DI-419.

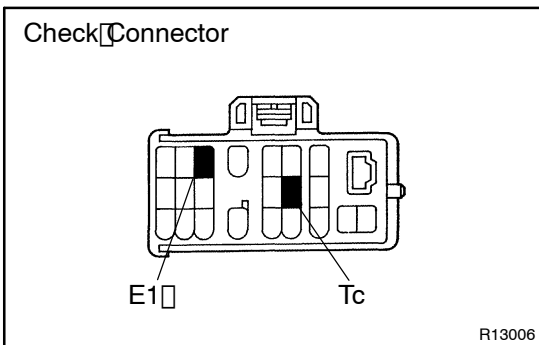

### 2. DTC CHECK (Using diagnosis check wire)

- (a) Present troubles codes:

Output the DTC.

- (1) Turn the ignition switch to the ACC or ON position and wait for approx. 20 seconds.
- (2) Using SST, connect terminals Tc and E1 of the check connector.

SST 09843-18020

#### NOTICE:

**Pay due attention to the terminal connecting position to avoid a malfunction.**

- (b) Past troubles codes:

Output the DTC.

- (1) Using a service wire, connect Terminals Tc and E1 of the check connector.

SST 09843-18020

- (2) Turn the ignition switch to the ACC or ON position and wait for approx. 20 seconds.

#### NOTICE:

**Pay due attention to the terminal connecting position to avoid a malfunction.**

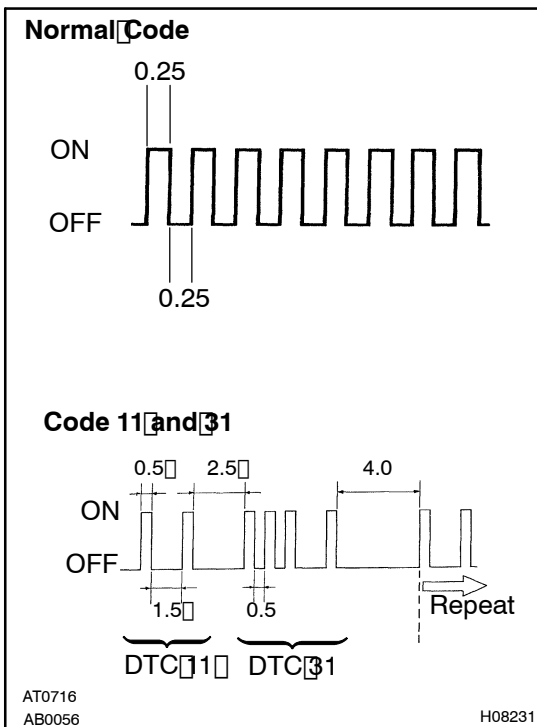

## (c) Read the DTC.

Read the 2-digit DTC as indicated by the number of times the SRS warning light blinks. As an example, the blinking patterns, normal, 11 and 31 are shown in the illustration.

- Normal code indication  
The light will blink 2 times per second.
- Malfunction code indication  
The first blinking output indicates the first digit of a 2-digit DTC. After a 0.5-second pause, the second blinking output will indicate the second digit.

If there are 2 or more codes, there will be a 2.5-second pause between each code. After all the codes have been output, there will be a 4.0-second pause and they will all be repeated.

## HINT:

- In the event of a number of trouble codes, indication will start from the smallest numbered code.
- If a DTC is not output or a DTC is output without terminal connection, proceed to the Tc terminal circuit inspection on [page DI-424](#).

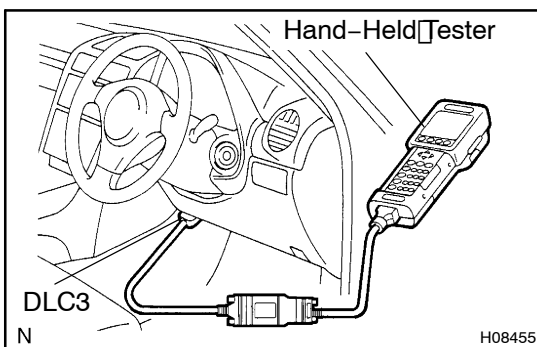
**3. DTC CHECK (Using hand-held tester)**

- (a) Hook up the hand-held tester to the DLC3.
- (b) Read the DTCs by following the prompts on the tester screen.

## HINT:

Please refer to the hand-held tester operator's manual for further details.

**4. DTC CLEARANCE (Not using service wire)**

When the ignition switch is turned off, the diagnostic trouble code is cleared.

## HINT:

DTC might not be cleared by turning the ignition switch OFF. In this case, proceed to the next step.

**5. DTC CLEARANCE (Using service wire)**

- (a) Connect the 2 service wires to terminals Tc and AB of check connector.
- (b) Turn the ignition switch to ACC or ON and wait for approx. 6 seconds.

- (c) Starting with the Tc terminal, ground alternately terminal Tc and terminal AB twice each in cycles of 1.0 second. Make sure that the terminals are grounded. Ensure the terminal Tc remains grounded.

**HINT:**

When alternately grounding terminals Tc and AB, release ground from one terminal and immediately ground the other terminal within an interval of 0.2 seconds.

If DTCs are not cleared, repeat the above procedure until the codes are cleared.

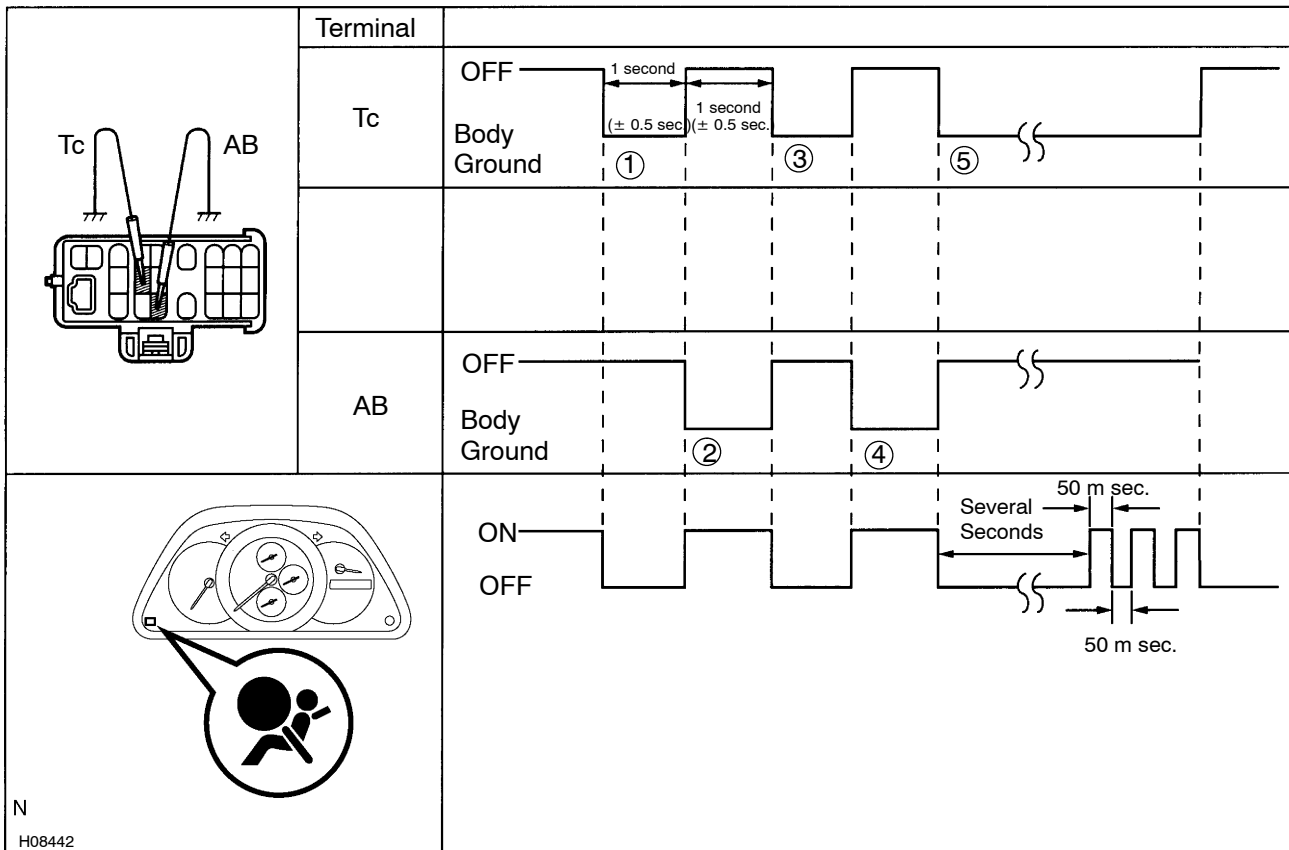

N  
H08442  
H01461

H08501

- (d) Several seconds after doing the clearing procedure, the SRS warning light will blink in a 50 m sec. cycle to indicate the codes which have been cleared.

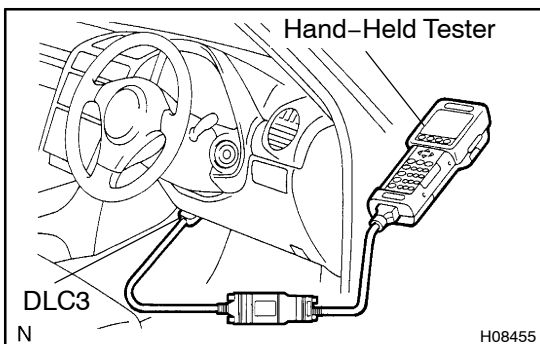

N  
DLC3  
H08455

**6. DTC CLEARANCE (Using hand-held tester)**

- (a) Hook up the hand-held tester to the DLC3.
- (b) Clear the DTCs by following the prompts on the tester screen.

**HINT:**

Please refer to the hand-held tester operation's manual for further details.

## **7. RELEASE METHOD OF AIRBAG ACTIVATION PREVENTION MECHANISM**

An airbag activation prevention mechanism is built into the connector for the squib circuit of the SRS.

When release of the airbag activation prevention mechanism is directed in the troubleshooting procedure as shown in the illustration of the connectors on the next pages, insert paper which has the same thickness as the male terminal between the terminal and the short spring.

### **CAUTION:**

**Never release the airbag activation prevention mechanism on the steering wheel pad connector.**

### **NOTICE:**

- **Do not release the airbag activation prevention mechanism unless specifically directed by the troubleshooting procedure.**
- **If the inserted paper is too thick the terminal and short spring may be damaged, so always use paper with the same thickness as the male terminal.**

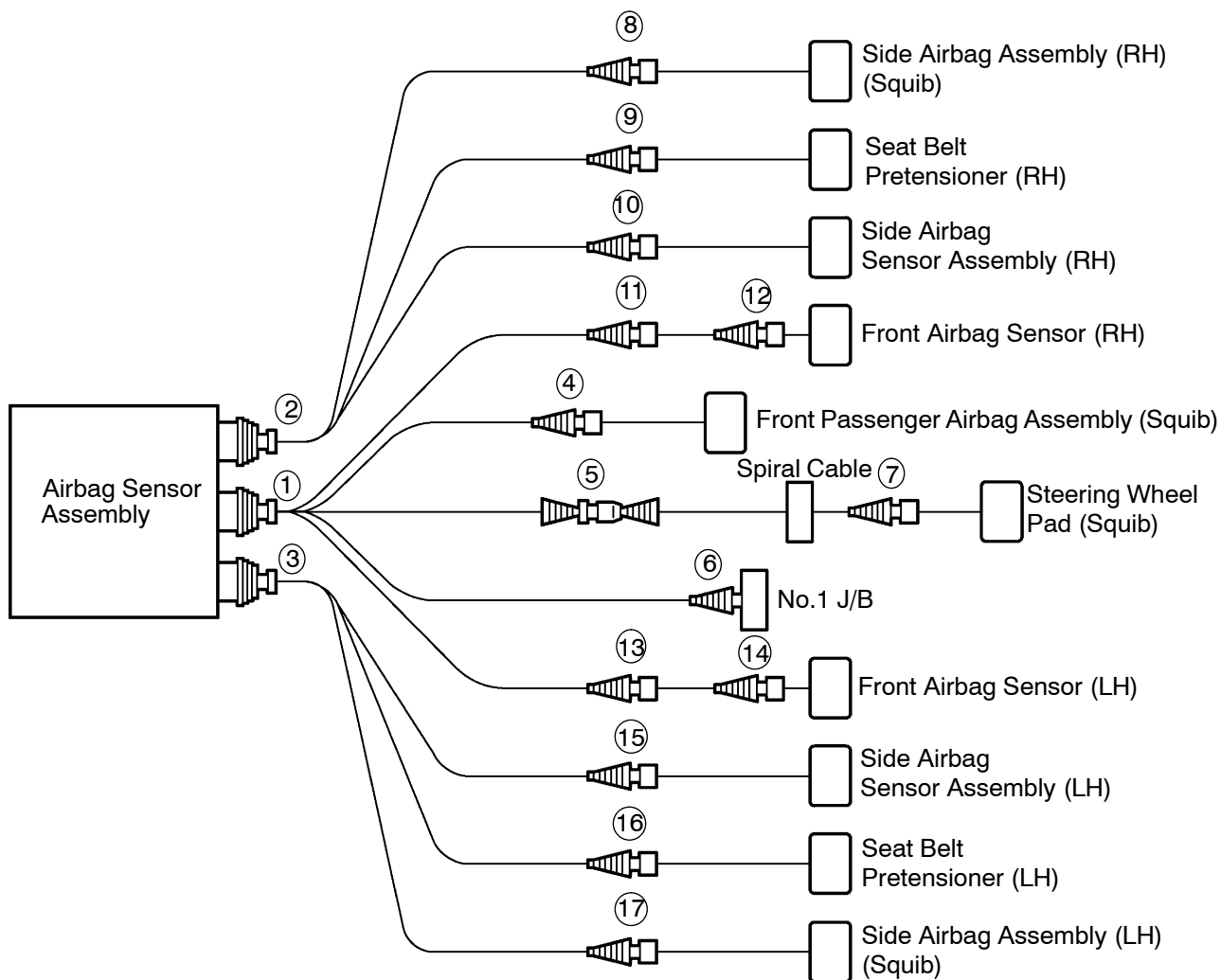

N

Airbag Sensor Assembly Connector

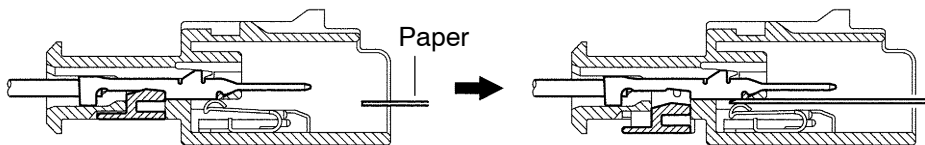
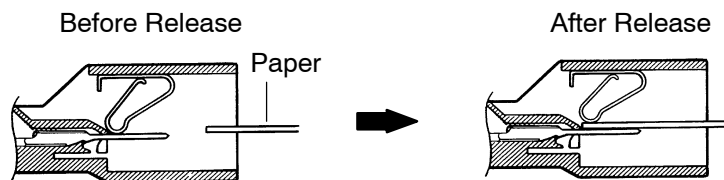
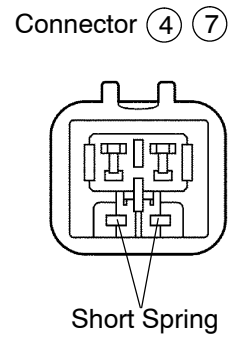
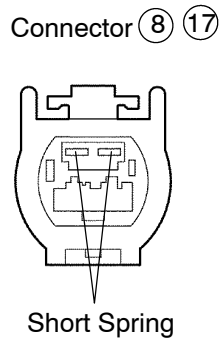
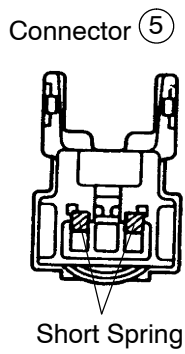
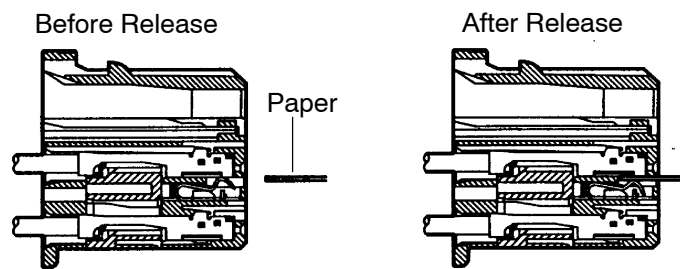
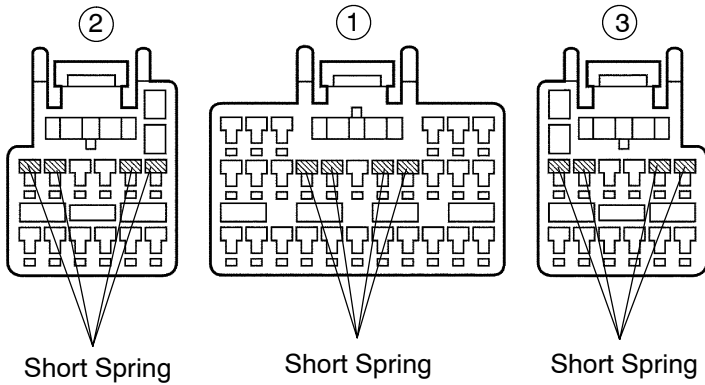

H01356  
 H01233  
 AB0130 H00992  
 AB0045 AB0046  
 H02249 H02248

H01358