

Light control switch circuit

WIRING DIAGRAM

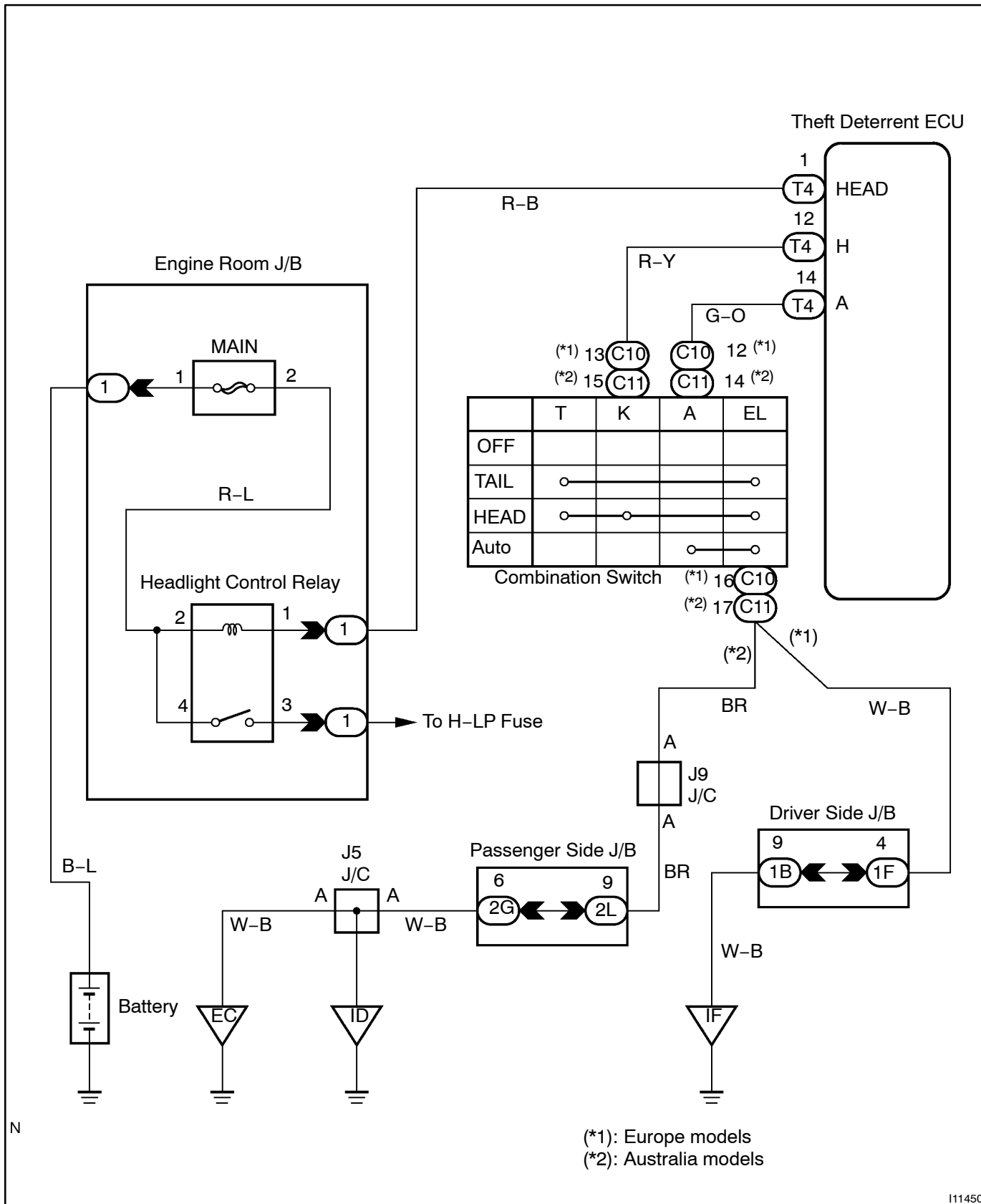

INSPECTION PROCEDURE

HINT:

In case of using the LEXUS hand-held tester, start the inspection from step 1 and in case of not using the LEXUS hand-held tester, start from step 2.

1 Check headlight control switch using LEXUS hand-held tester.

PREPARATION:

Connect the LEXUS hand-held tester to the DLC3.

CHECK:

Check the headlight control switch using DATA LIST.

OK:

Terminal (tester display) Switch position	Headlight Switch (Tail)	Headlight Switch (Head)	Auto Light Switch
OFF	OFF	OFF	OFF
TAIL	ON	OFF	OFF
HEAD	ON	ON	OFF
AUTO	OFF	OFF	ON

OK

Proceed to next circuit inspection shown in problem symptoms table. (See page DI-442).

NG

2 Check headlight control switch (See page BE-30).

NG

Replace the headlight control switch.

OK

3 Check wireharness and connector between headlight control switch and Body ECU (See page IN-32).

NG

Repair or replace wireharness or connector.

OK

Proceed to next circuit inspection shown on problem symptoms table (See page DI-442).