

Engine Hood Courtesy Switch Circuit

CIRCUIT DESCRIPTION

The engine hood courtesy switch is built into the engine hood lock assembly and goes ON when the engine hood is opened and goes OFF when the engine hood is closed.

WIRING DIAGRAM

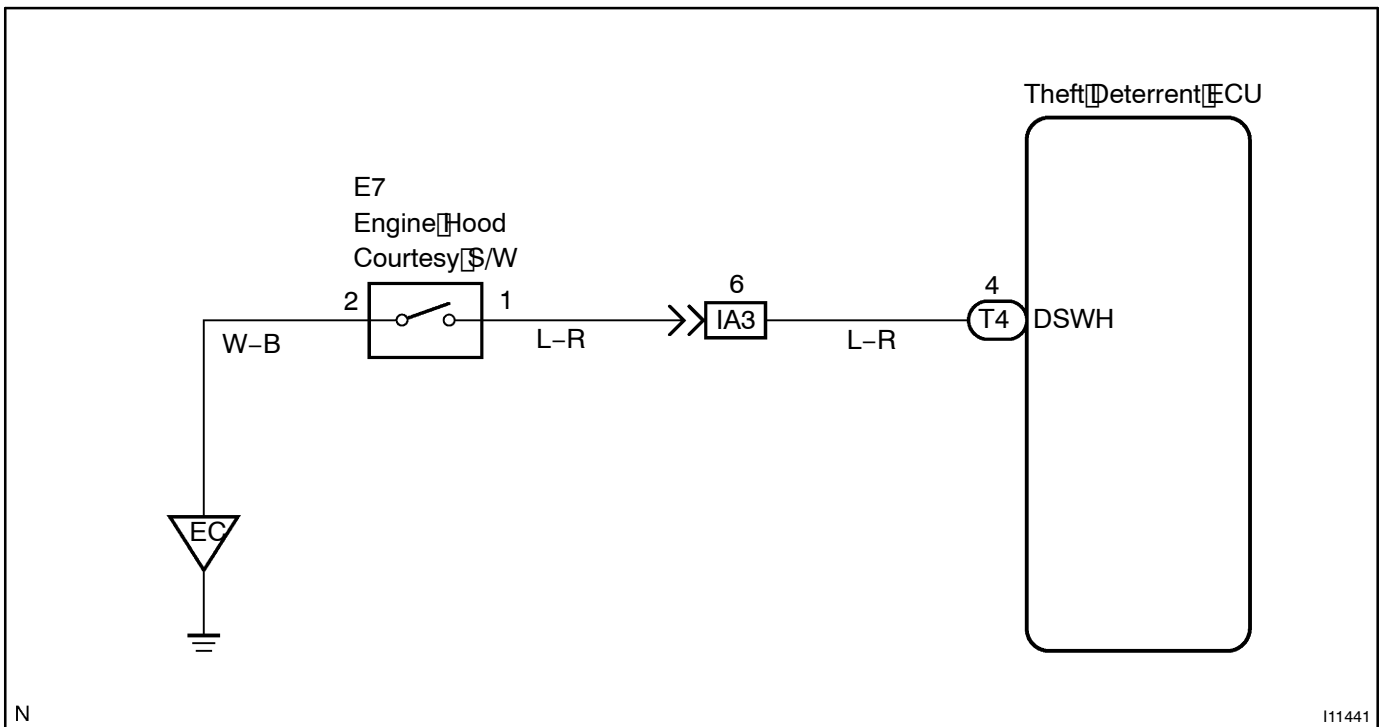

INSPECTION PROCEDURE

HINT:

In case of using the LEXUS hand-held tester, start the inspection from step 1 and in case of not using the LEXUS hand-held tester, start from step 2.

- 1 Check hood courtesy switch using LEXUS hand-held tester.

PREPARATION:

Connect the LEXUS hand-held tester to the DLC3.

CHECK:

Check the hood courtesy switch using DATA LIST.

OK

Proceed to next circuit inspection shown in problem symptoms table (See page DI-442).

NG

2 Check engine hood courtesy switch.

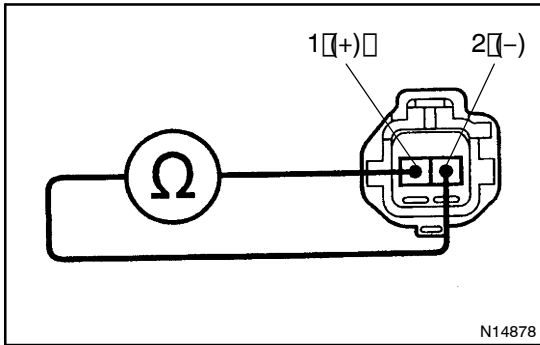

PREPARATION:

- (a) Remove engine hood lock assembly.
- (b) Disconnect engine hood courtesy switch connector.

CHECK:

Check continuity between terminals 1 and 2 when engine hood lock is locked and unlocked.

OK:

Engine hood lock	Tester connection	Specified condition
LOCK	-	No continuity
UNLOCK	1 - 2	Continuity

NG

Replace engine hood courtesy switch.

OK

3 Check harness and connector between theft deterrent ECU and switch, switch and body ground (See page IN-32).

NG

Repair or replace harness or connector.

OK

Check and replace theft deterrent ECU (See page IN-32).