

<b>DTC</b>	<b>P1520/52</b>	<b>Stop light switch circuit</b>
------------	-----------------	----------------------------------

## CIRCUIT DESCRIPTION

When the brake pedal is depressed, the stop light switch sends a signal to the Engine and ECT ECU. When the Engine and ECT ECU receives this signal, it cancels the cruise control.

A fail-safe function is provided so that the cancel functions normally, even if there is a malfunction in the stop light signal circuit.

The cancel condition is that battery voltage is supplied to terminal STP.

When the brake is on, battery voltage is normally applied through the STOP fuse and stop light switch to terminal STP of the Engine and ECT ECU, and the Engine and ECT ECU turns the cruise control OFF.

If the harness connected to terminal STP has an open circuit, terminal STP will have battery voltage and the cruise control will be turned OFF.

DTC No.	Detection Item	Trouble Area
52	Stop light switch circuit.	<ul style="list-style-type: none"> <li>• Stop light switch</li> <li>• Harness or connector between Engine and ECT ECU and stop light switch circuit</li> <li>• Engine and ECT ECU</li> </ul>

## WIRING DIAGRAM

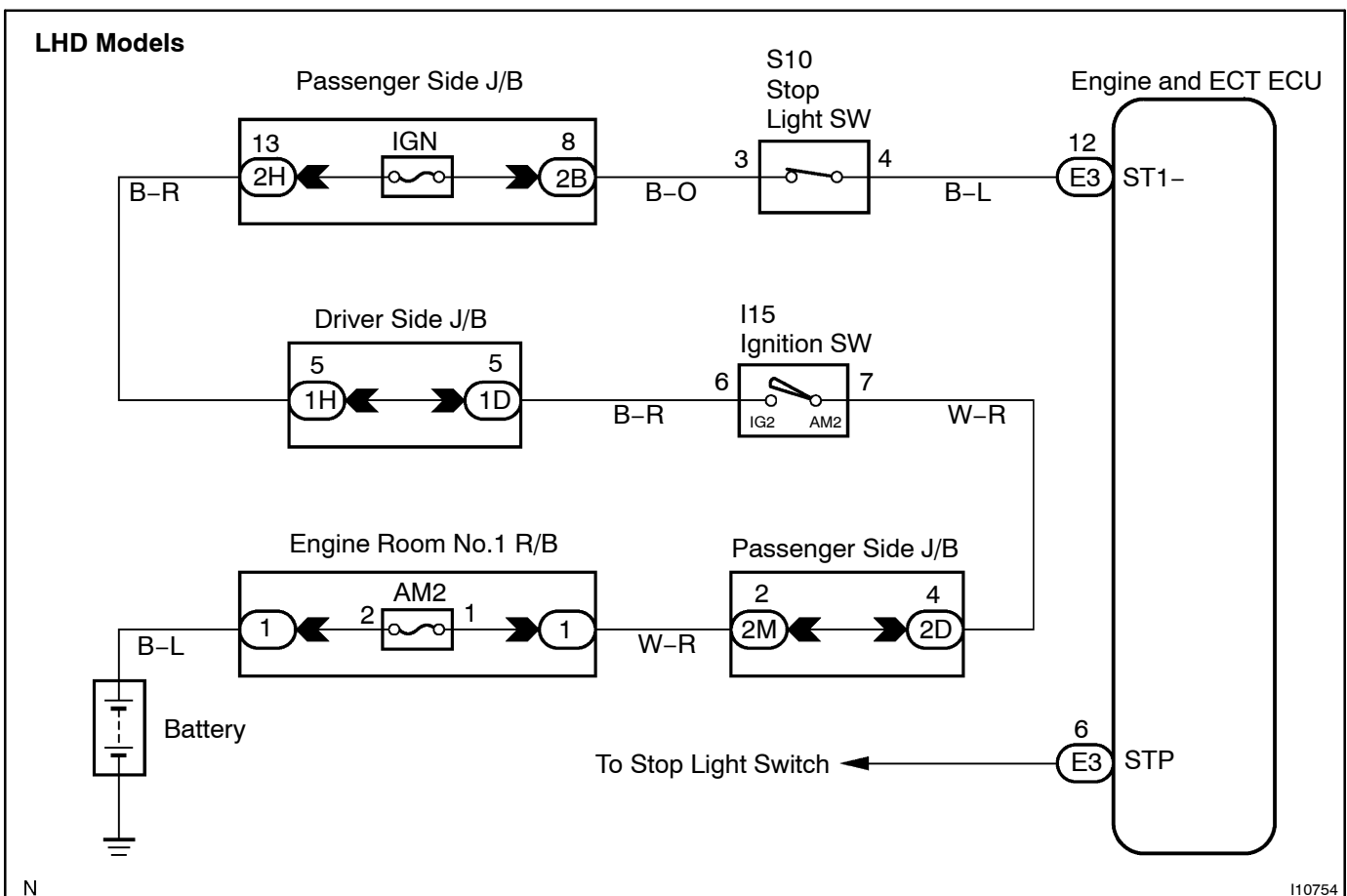



## INSPECTION PROCEDURE

### HINT:

In case of using the LEXUS hand-held tester, start the inspection from step 1 and in case of not using the LEXUS hand-held tester, start from step 2.

**1** Check stop light switch using LEXUS hand-held tester.

### PREPARATION:

Connect the LEXUS hand-held tester to the DLC3.

### CHECK:

Check the stop light switch using DATALIST.

### OK:

Condition	Stop light switch 1 (Sub CPU)	Stop light switch 2 (Sub CPU)	Stop light switch 2 (Main CPU)
Depressed	ON	ON	ON
Released	OFF	OFF	OFF

### HINT:

- Stop light SW 1 has a function to disconnect the connection (OFF) when depressing the pedal, however, Engine and ECT ECU controls by the logic drivers, so with the LEXUS hand-held tester, it displays ON.
- Stop light SW 1 indicates the input of ST1-terminal and Stop light SW 2 indicates the input of STP terminal.

OK

Proceed to next circuit inspection shown in problem symptom table (See page DI-487).

NG

**2** Check operation of stop light.

### CHECK:

Check that stop light comes on when brake pedal is depressed, and turns off when brake pedal is released.

NG

Check stop light system (See page BE-65).

OK

### 3 Check voltage between terminal STP of Engine and ECT ECU connector and body ground.

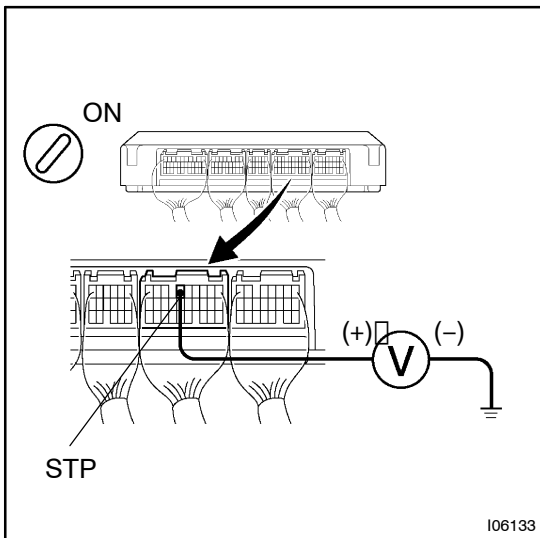

#### PREPARATION:

- Remove the Engine and ECT ECU with connectors still connected.
- Turn Ignition switch ON.

#### CHECK:

Measure voltage between terminal STP of Engine and ECT ECU connector and body ground, when the brake pedal is depressed and released.

#### OK:

Depressed	10 - 14 V
Released	Below 1 V

OK

Proceed to next circuit inspection shown in problem symptoms table (See page DI-487).

NG

### 4 Check voltage between terminal ST1- of Engine and ECT ECU connector and body ground.

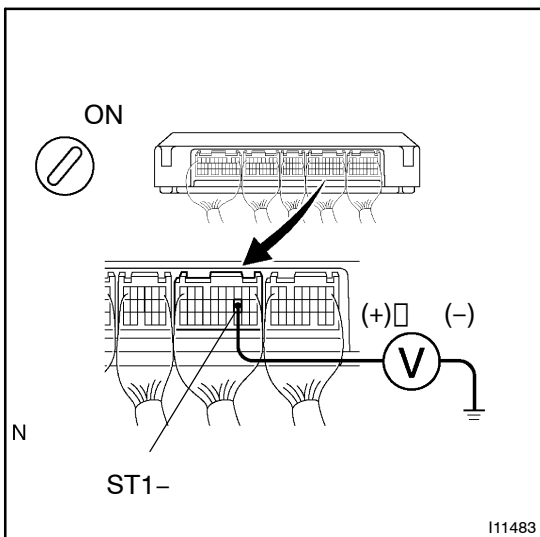

#### PREPARATION:

- Remove the Engine and ECT ECU with connectors still connected.
- Turn Ignition switch ON.

#### CHECK:

Measure voltage between terminal ST1- of Engine and ECT ECU connector and body ground, when the brake pedal is depressed and released.

#### OK:

Depressed	Below 1 V
Released	10 - 14 V

OK

Proceed to next circuit inspection shown in problem symptoms table (See page DI-487).

NG

5 Check wire harness and connector between terminal STP of Engine and ECT ECU and stop light switch, and terminal ST1 of Engine and ECT ECU and stop light switch (See page N-32).

NG

Repair or replace harness or connector.

OK

Check and replace Engine and ECT ECU (See page N-32).