

Taillight relay circuit

CIRCUIT DESCRIPTION

Taillight relay will be "ON" by operating the taillight switch. The transistor which activates the tail light relay has two sorts: one activates by the tail light switch for fail safe and the other activates by CPU.

WIRING DIAGRAM

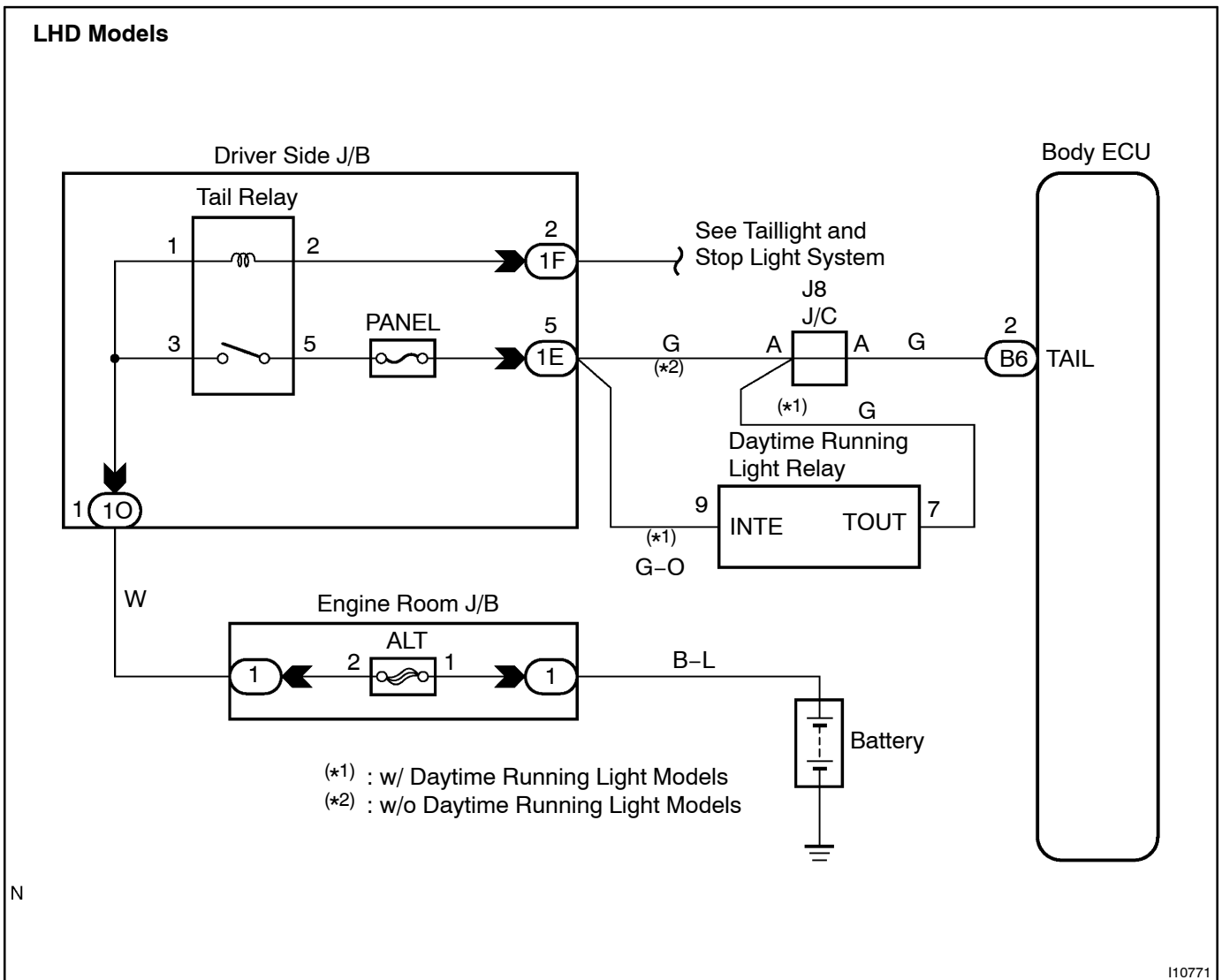

RHD Models

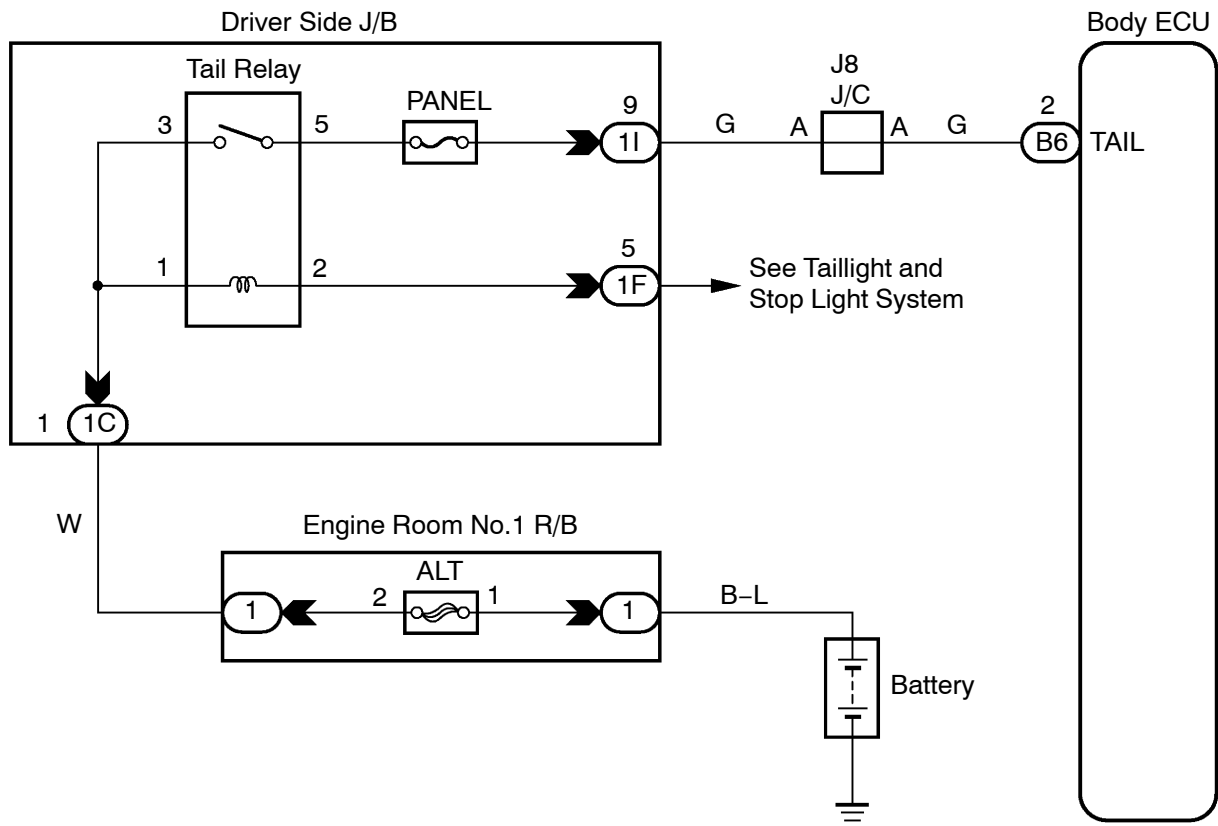

N

I11457

INSPECTION PROCEDURE

1 Check taillight relay (See page BE-30).

NG

Replace the taillight relay.

OK

2 Check wireharness and connector between taillight relay and Body ECU, battery and taillight relay.

NG

Repair or replace wireharness or connector.

OK

Proceed to next circuit inspection shown on problem symptoms table (See page DI-554).