

Key unlock warning switch circuit

CIRCUIT DESCRIPTION

The key unlock warning switch goes on when the ignition key is inserted in the key cylinder and goes off when the ignition key is removed.

The ECU operates the key confinement prevention function while the key unlock warning switch is on.

WIRING DIAGRAM

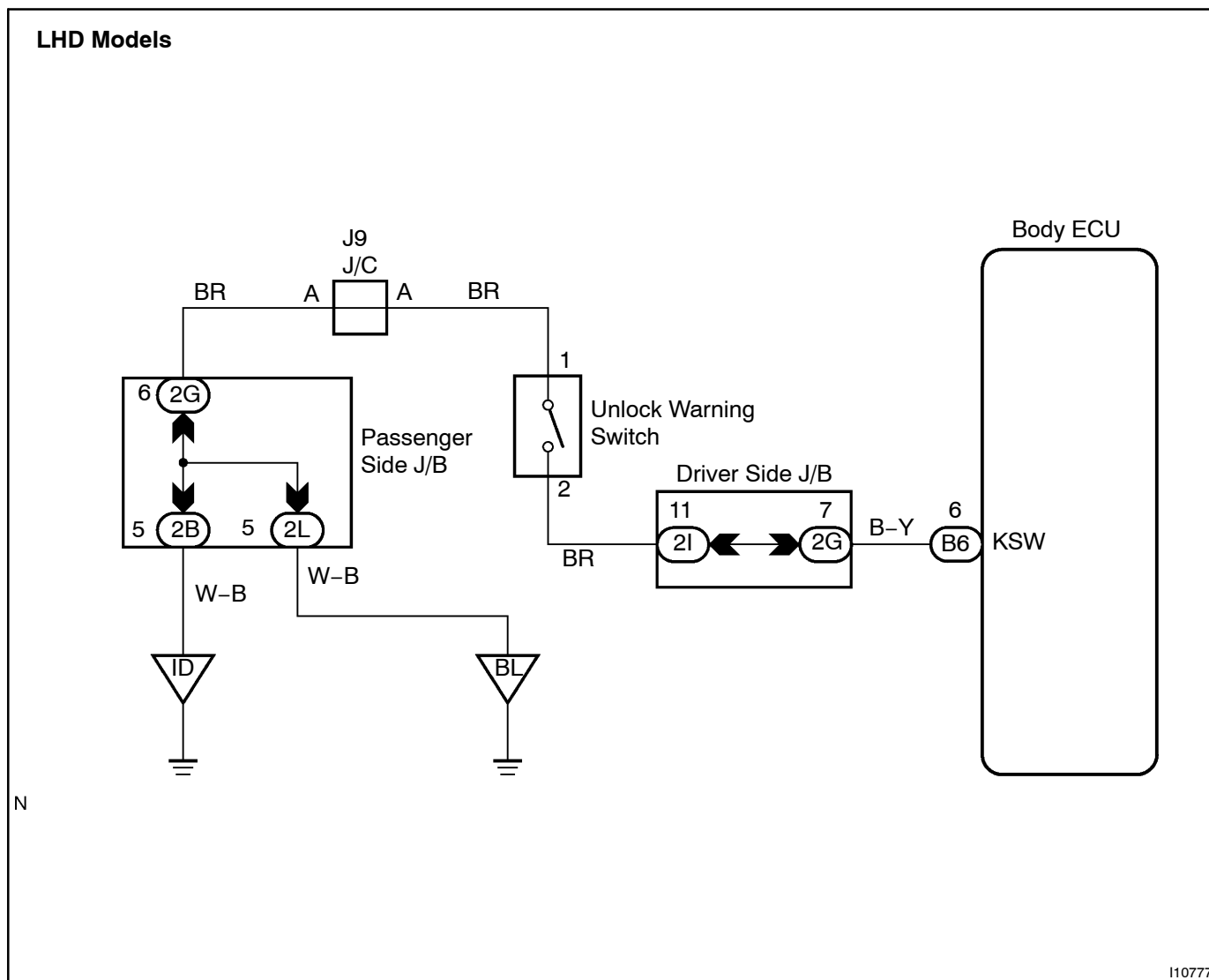

RHD Models

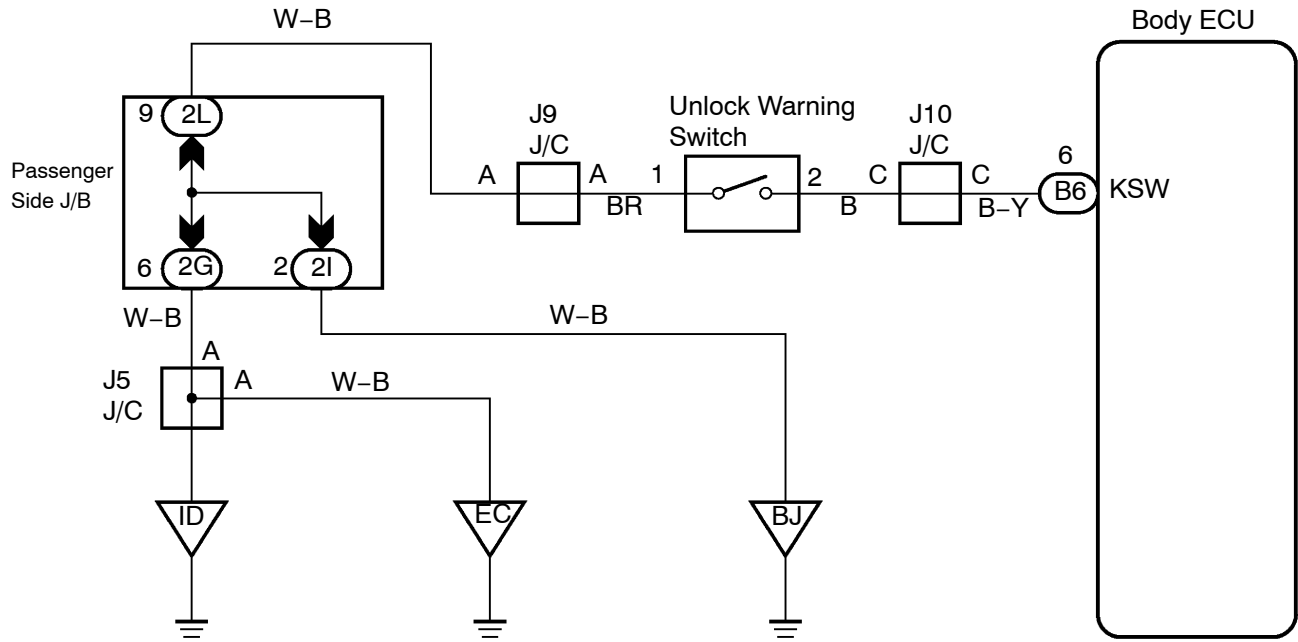

N

INSPECTION PROCEDURE

1 Check key unlock warning switch (See page BE-23).

NG

Replace the key unlock warning switch.

OK

2 Check wireharness and connector between key unlock warning switch and Body ECU.

NG

Repair or replace wireharness or connector.

OK

Proceed to next circuit inspection shown on problem symptoms table (See page DI-554).