

ACC Power Source Circuit

CIRCUIT DESCRIPTION

This is the power source for A/C control assembly and servomotors, etc.

WIRING DIAGRAM

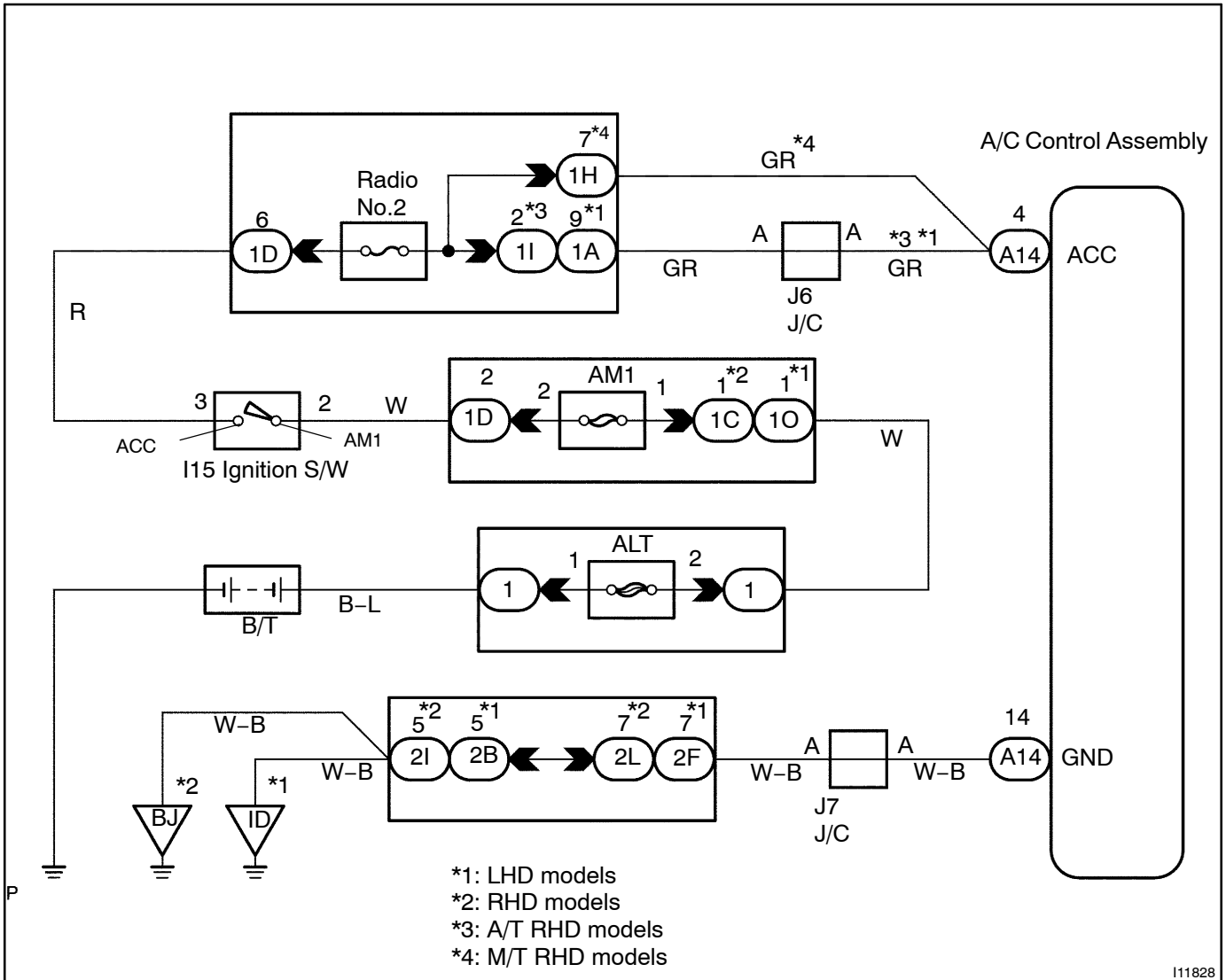

INSPECTION PROCEDURE

- 1 Check voltage between terminals ACC and GND of A/C control assembly connector.

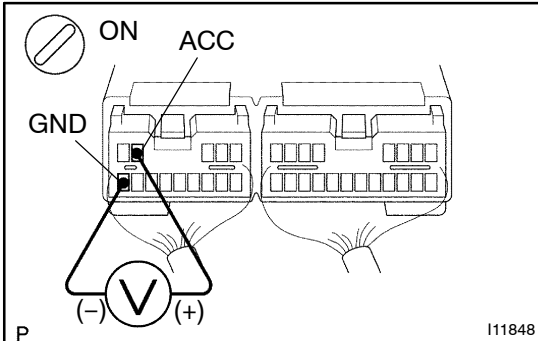
**PREPARATION:**

Remove A/C control assembly with connectors still connected.

CHECK:

- Turn ignition switch to ACC.
- Measure voltage between terminals ACC and GND of A/C control assembly.

OK:

Voltage : Battery voltage

OK

Proceed to next circuit inspection shown on problem symptoms table (See page DI-674).

NG

- 2 Check continuity between terminal GND of A/C control assembly and body ground.

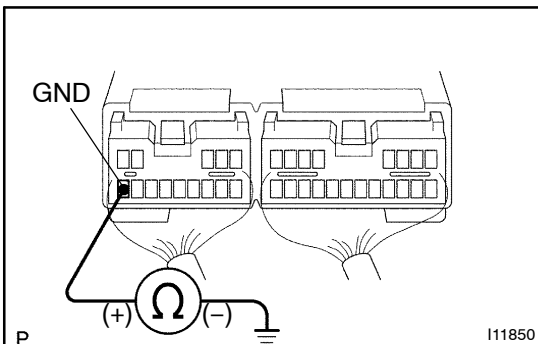
**CHECK:**

Measure resistance between terminal GND of A/C control assembly and body ground.

OK:

Resistance : 0 Ω (continuity)

NG

Repair or replace harness or connector.

OK

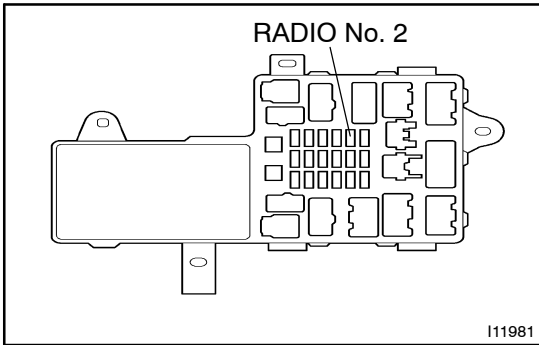
3 Check RADIO No.2 fuse.**PREPARATION:**

Remove RADIO No.2 fuse from driver side J/B.

CHECK:

Check continuity of RADIO No.2.

OK:

Continuity

NG

Check for short in all the harness and components connected to the RADIO No.2 fuse (See attached wiring diagram).

OK

Check and repair harness and connector between A/C control assembly and battery.