

EFI SYSTEM PRECAUTION

SF0N1-04

1. BEFORE WORKING ON FUEL SYSTEM, DISCONNECT NEGATIVE (-) TERMINAL CABLE FROM BATTERY

HINT:

Any diagnostic trouble code retained by the engine ECU will be erased when the battery negative (-) terminal cable is removed from the battery.

Therefore, if necessary, read the diagnostic trouble code(s) before removing the negative (-) terminal cable from the battery.

2. DO NOT SMOKE OR WORK NEAR AN OPEN FLAME WHEN WORKING ON FUEL SYSTEM

3. KEEP GASOLINE AWAY FROM RUBBER OR LEATHER PARTS

4. MAINTENANCE PRECAUTIONS

(a) In the event of engine misfire, these precautions should be taken.

- (1) Check proper connection of battery terminals, etc.
- (2) After repair work, check that the ignition coil terminals and all other ignition system lines are reconnected securely.
- (3) When cleaning the engine compartment, be especially careful to protect the electrical system from water.

(b) Precautions when the handling oxygen sensors.

- (1) Do not allow oxygen sensor to drop or hit against an object.
- (2) Do not allow the sensor to come into contact with water.

5. IF VEHICLE IS EQUIPPED WITH MOBILE RADIO SYSTEM (HAM, CB, ETC.)

If the vehicle is equipped with a mobile communication system, refer to the precaution in the IN section.

6. AIR INDUCTION SYSTEM

- (a) Separation of the engine oil dipstick, oil filler cap, PCV hose, etc. may cause the engine to run out of tune.
- (b) Disconnection, looseness or cracks in the parts of the air induction system between the throttle body and cylinder head will cause air suction and cause the engine to run out of tune.

7. ELECTRONIC CONTROL SYSTEM

- (a) Before removing EFI wiring connectors, terminals, etc., first disconnect the power by either turning the ignition switch OFF or disconnecting the negative (-) terminal cable from the battery.

HINT:

Always check the diagnostic trouble code before disconnecting the negative (-) terminal cable from the battery.

- (b) When installing the battery, be especially careful not to incorrectly connect the positive (+) and negative (-) cable terminals.
- (c) Do not permit parts to receive a severe impact during removal or installation. Handle all EFI parts carefully, especially the engine ECU.
- (d) Do not be careless during troubleshooting as there are numerous transistor circuits and even slight terminal contact can further troubles.
- (e) Do not open the ECU cover.
- (f) When inspecting during rainy weather, take care to prevent entry of water. Also, when washing the engine compartment, prevent water from getting on the EFI parts and wiring connectors.
- (g) Parts should be replaced as an assembly.
- (h) Care is required when pulling out and inserting wiring connectors.
- (1) Release the lock and pull out the connector, pulling on the connectors.
 - (2) Fully insert the connector and check that it is locked.
- (i) When inspecting a connector with a volt/ohmmeter.
- (1) Carefully take out the water-proofing rubber if it is a water-proof type connector.
 - (2) Insert the test probe into the connector from wiring side when checking the continuity, amperage or voltage.
 - (3) Do not apply unnecessary force to the terminal.
 - (4) After checking, install the water-proofing rubber on the connector securely.

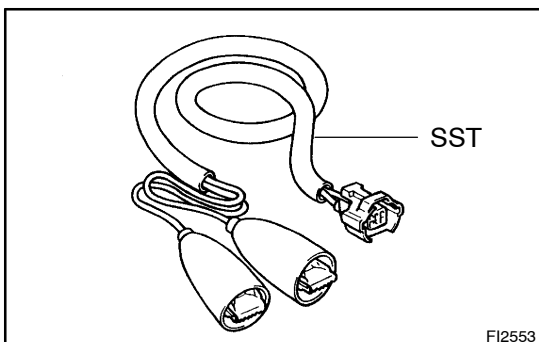

- (5) Use SST for inspection or test of the injector or its wiring connector.

SST 09842-30070

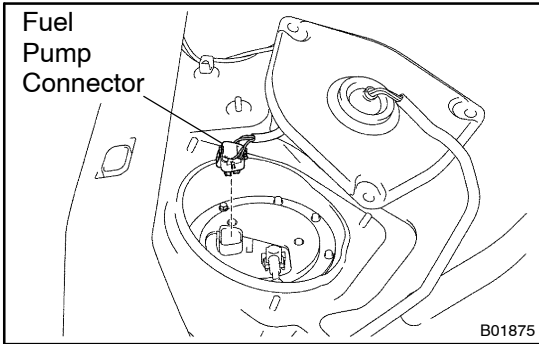

8. FUEL SYSTEM

- (a) When disconnecting the high pressure fuel line, a large amount of gasoline will spill out, so observe these procedures:
- (1) Disconnect the fuel pump connector.
 - (2) Start the engine. After the engine has stopped on its own, turn the ignition switch OFF.
 - (3) Put a container under the connection.
 - (4) Slowly loosen the connection.
 - (5) Disconnect the connection.
 - (6) Plug the connection with a rubber plug.
 - (7) Reconnect the fuel pump connector.

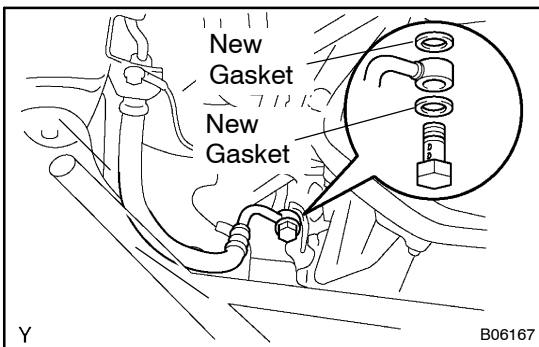

- (b) When connecting the flare nut or union bolt on the high pressure pipe union, observe these procedures:
- (1) Union Bolt Type:
Always use a new gasket.
 - (2) Union Bolt Type:
Tighten the union bolt by hand.
 - (3) Union Bolt Type:
Tighten the union bolt to the specified torque.

Torque: 29 N·m (300 kgf·cm, 22 ft·lbf)

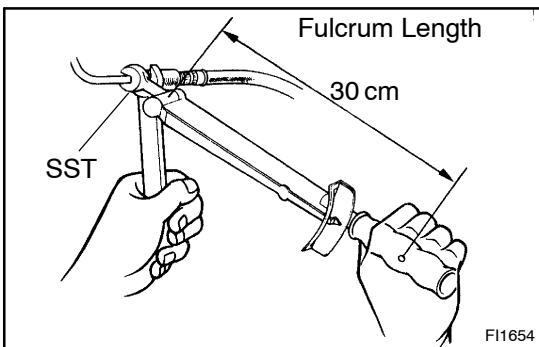

- (4) Flare Nut Type:
Apply a light coat of engine oil to the flare and tighten the flare nut by hand.
- (5) Flare Nut Type:
Using SST, tighten the flare nut to the specified torque.

SST 09631-22020

NOTICE:

Do not rotate the fuel pipe, when tightening the flare nut.

**Torque: 30 N·m (310 kgf·cm, 22 ft·lbf) for using SST
38 N·m (387 kgf·cm, 28 ft·lbf)**

HINT:

Use a torque wrench with a fulcrum length of 30 cm (11.81 in.).

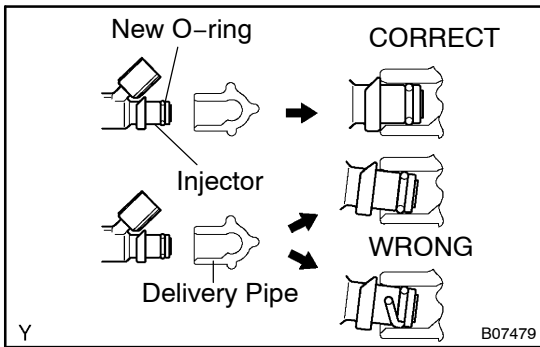

- (c) Observe these precautions when removing and installing the injectors.
- (1) Never reuse the O-ring.
 - (2) When placing a new O-ring on the injector, take care not to damage it in any way.
 - (3) Coat a new O-ring with spindle oil or gasoline before installing—never use engine, gear or brake oil.

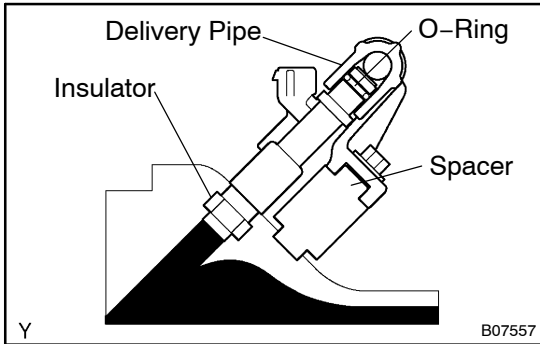

- (d) Install the injector to the delivery pipe and intake manifold as shown in the illustration. Before installing the injector, must apply spindle oil or gasoline on the place where a delivery pipe or touches an O-ring of the injector.

- (e) Observe these precautions when disconnecting the fuel tube connector (quick type):
- (1) Check that there is any dirt like mud on the pipe and around the connector before disconnecting them and clean the dirt away.
 - (2) Be sure to disconnect with hands.

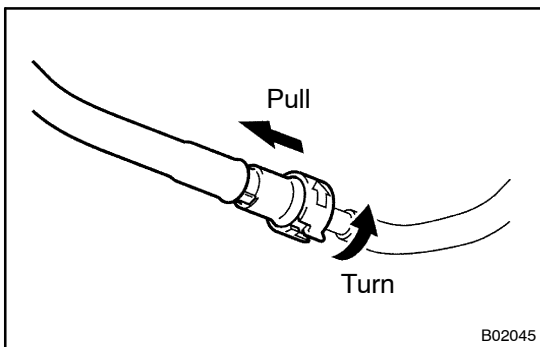

- (3) When the connector and the pipe are stuck, push and pull the connector to free to disconnect and pull it out. Do not use any tool at this time.
- (4) Inspect that there is any dirt or the likes on the seal surface of the disconnected pipe and clean it away.
- (5) Prevent the disconnected pipe and connector from damaging and mixing foreign objects by covering them with a vinyl bag.

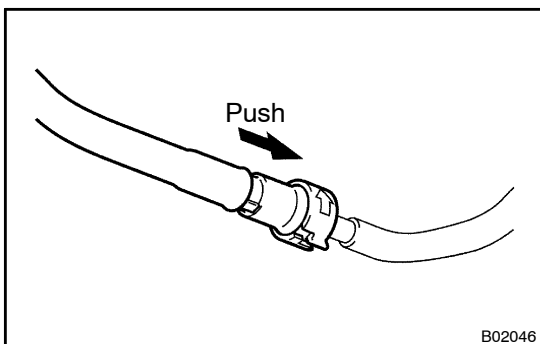

- (f) Observe these precautions when connecting the fuel tube connector (quick type):
- (1) Check that there is any damage or foreign objects on the connected part of the pipe.
 - (2) Match the axis of the connector with axis of the pipe, and push in the connector until the connector makes a "click" sound. In case the connections is tight, apply little amount of new engine oil on the tip of the pipe.

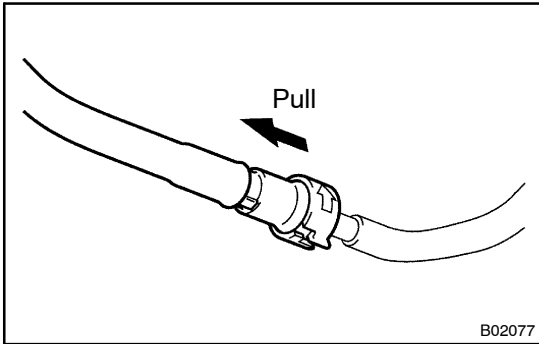

- (3) After having finished the connection, check that the pipe and the connector are securely connected by pulling them.
 - (4) Check that there is any fuel leakage.
- (g) Observe these precautions when handling nylon tube.
- (1) Pay attention not to turn the connected part of the nylon tube and quick connector with force when connecting them.
 - (2) Pay attention not to kink the nylon tube.
 - (3) Do not remove the EPDM protector on the outside of the nylon tube.
 - (4) Must not close the piping with the nylon tube by bending it.

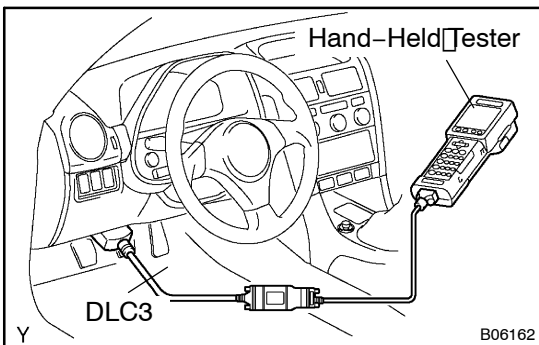

- (h) Check that there are no fuel leaks after doing maintenance anywhere on the fuel system.
- (1) Connect a hand-held tester to the DLC3.
 - (2) Turn the ignition switch ON and push the hand-held tester main switch ON.

NOTICE:**Do not start the engine.**

- (3) Select the ACTIVE TEST mode on the hand-held tester.
- (4) Please refer to the hand-held tester operator's manual for further details.
- (5) If you have no hand-held tester, connect the positive (+) and negative (-) leads from the battery to the fuel pump connector. (See page FI-6)
- (6) Check that there are no leaks from any part of the fuel system.
- (7) Turn the ignition switch OFF.
- (8) Disconnect the hand-held tester from the DLC3.
- (9) Start the engine.

NOTICE:**Keep cranking the engine until the air is removed from the fuel line.**

- (10) After the engine starts, check again that there are no fuel leaks.