

REASSEMBLY

1. INSTALL HUB SLEEVE NO. 2

- (a) Install the hub sleeve No. 1 to clutch hub No. 1.
- (b) Install the shifting key and spring to clutch hub.
- (c) While pushing the spring, install the shifting key ball.

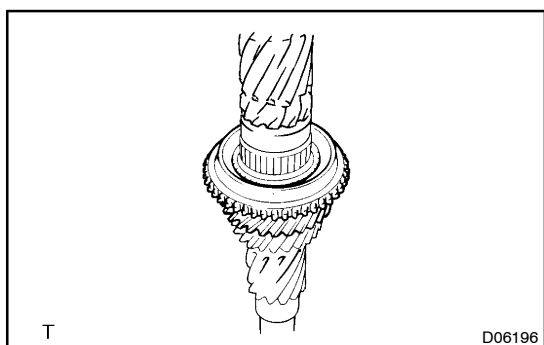

2. INSTALL 3RD GEAR

- (a) Apply the gear oil to the shaft, 3rd gear bearing, inner of gear and cone of gear.
- (b) Install the 3rd gear bearing and 3rd gear to the counter shaft.

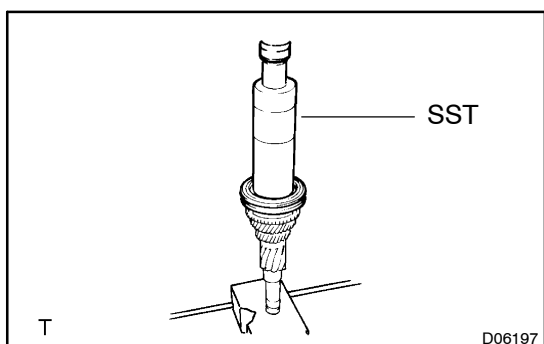

3. INSTALL CLUTCH HUB NO. 2

- (a) Install the synchronizer ring No. 1 (for 3rd gear) to the 3rd gear.
- (b) Using SST and press, install the clutch hub No. 3.
SST 09316-60011 (09316-00011)

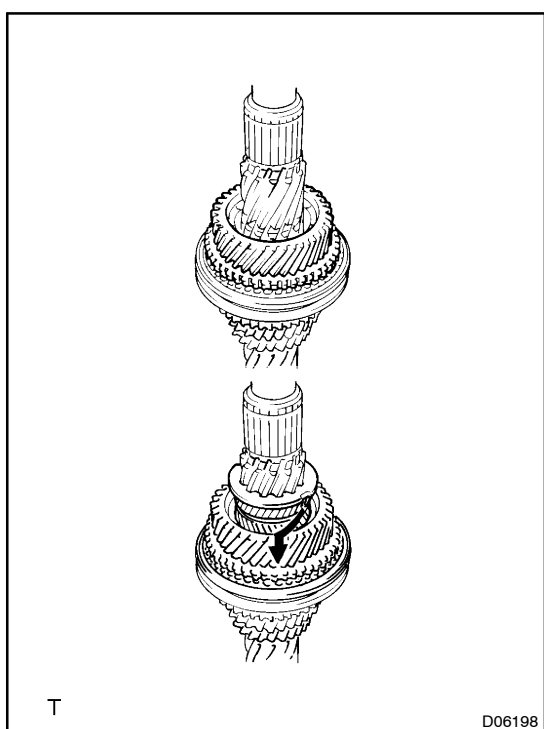

4. INSTALL 4TH SPEED GEAR

- (a) Install the synchronizer ring No. 1 (for 4th gear) to the clutch hub No. 2.
- (b) Apply the gear oil to 4th gear bearing gear and cone of counter shaft 4th gear.
- (c) Install the counter shaft 4th speed gear and 4th gear bearing inner race to the counter shaft.
- (d) Install the 4th gear washer and 4th washer retaining ring.

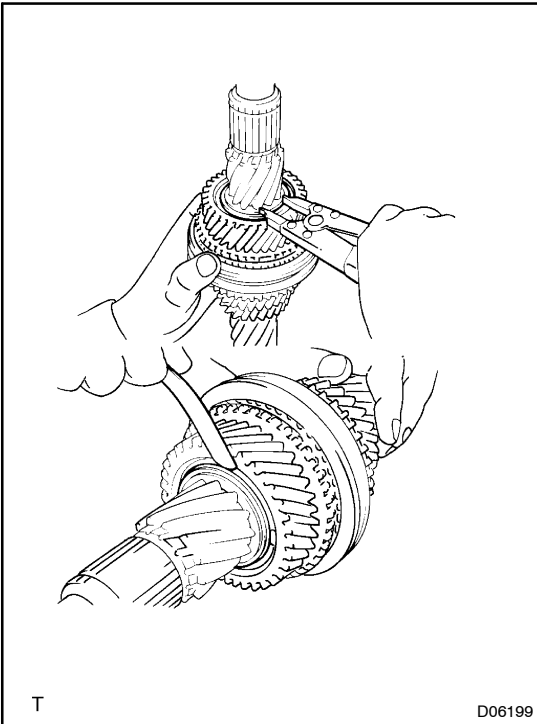

5. INSTALL 4TH WASHER RETAINING SNAP RING

(a) Select a snap ring that allows the minimum axial play.

Mark	Thickness mm (in.)
A	3.75 (0.1476)
B	3.80 (0.1496)
C	3.85 (0.1516)
D	3.90 (0.1535)
E	3.95 (0.1555)
F	4.00 (0.1575)
G	4.05 (0.1594)
H	4.10 (0.1614)

(b) Using a snap ring expander, install the snap ring.

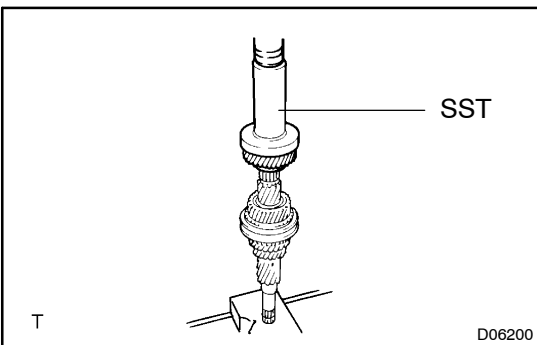

6. INSTALL COUNTER GEAR

Using SST and press, install the counter gear.

SST 09309-36010

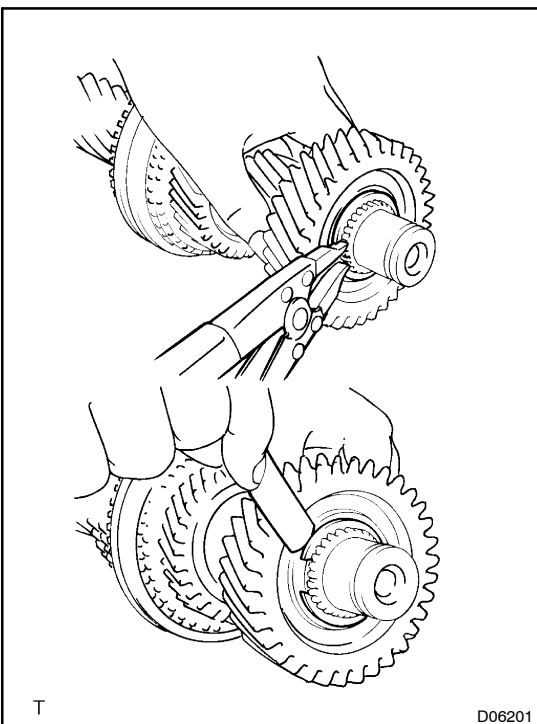

7. INSTALL CLUTCH HUB NO. 3 SHAFT SNAP RING

(a) Select a snap ring that allows the minimum axial play.

Mark	Thickness mm (in.)
A	1.80 (0.0709)
B	1.85 (0.0728)
C	1.90 (0.0748)
D	1.95 (0.0768)
E	2.00 (0.0787)
F	2.05 (0.0807)

(b) Using a snap ring expander, install the snap ring.

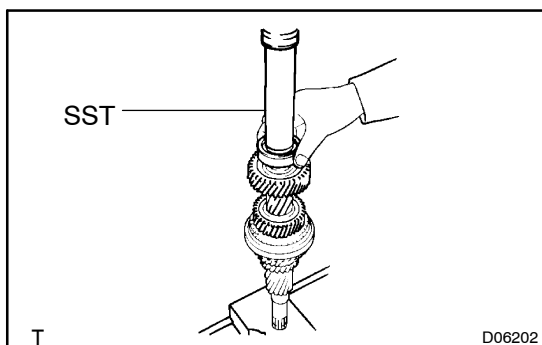

8. INSTALL FRONT BEARING

Using SST and press, install the counter gear front bearing.

SST 09330-50010

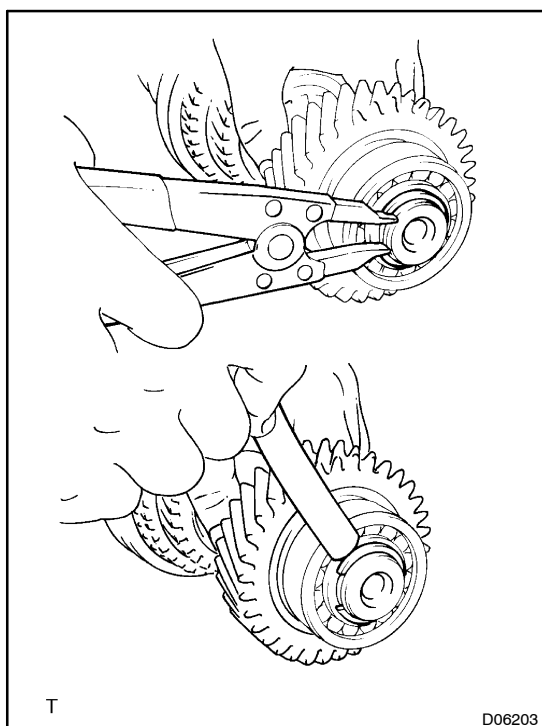

9. INSTALL FRONT BEARING SNAP RING NO. 2

(a) Select a snap ring that allows the minimum axial play.

Mark	Thickness mm (in.)
1	2.05 (0.0807)
2	2.10 (0.0827)
3	2.15 (0.0846)
4	2.20 (0.0866)
5	2.25 (0.0886)
6	2.30 (0.0906)

(b) Using a snap ring expander, install the snap ring.