

## OPERATION

### 1. STEERING WHEEL PAD (with AIRBAG)

The inflator and bag of the SRS are stored in the steering wheel pad and cannot be disassembled. The inflator contains a squib, igniter charge, gas generant, etc., and inflates the bag when instructed by the airbag sensor assembly.

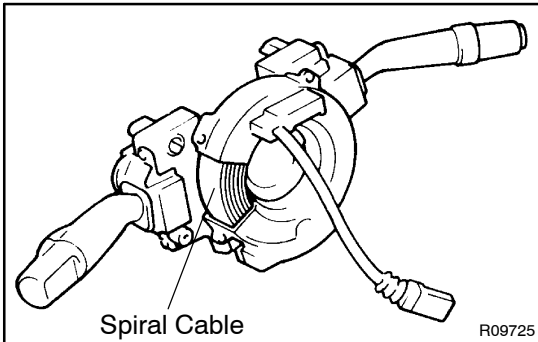

### 2. SPIRAL CABLE (in COMBINATION SWITCH)

A spiral cable is used as an electrical joint from the vehicle body side to the steering wheel.

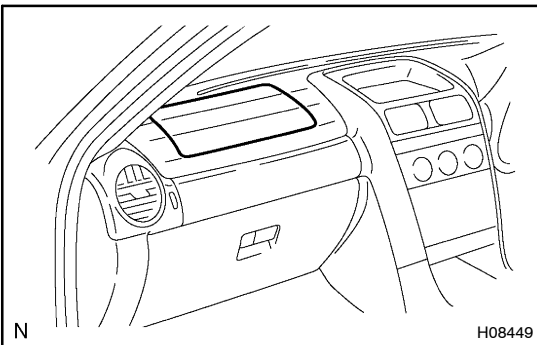

### 3. FRONT PASSENGER AIRBAG ASSEMBLY

The inflator and bag of the SRS are stored in the front passenger airbag assembly and cannot be disassembled. The inflator contains a squib, igniter charge and gas generant, etc., and inflates the bag when instructed by the airbag sensor assembly.

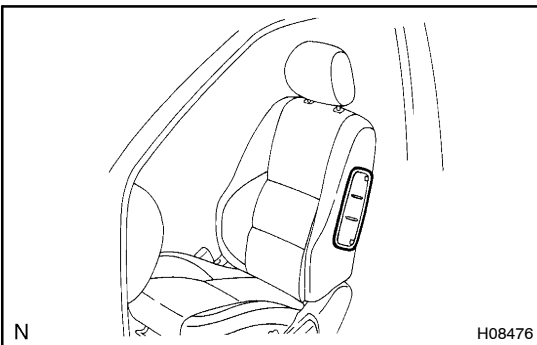

### 4. SIDE AIRBAG ASSEMBLY

The inflator and bag of the SRS side airbag are stored in the side airbag assembly and cannot be disassembled. The inflator contains a squib, igniter charge and gas generant, etc., and inflates the bag when instructed by the side airbag sensor assembly.

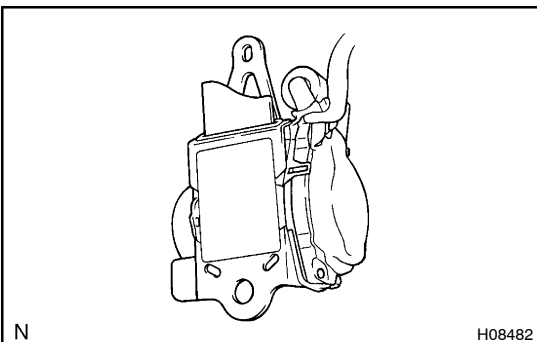

### 5. SEAT BELT PRETENSIONER

The seat belt pretensioner system is a component of the front seat outer belt. The pretensioner contains a squib, gas generant, wire, piston, etc., and operates in the event of a frontal collision.

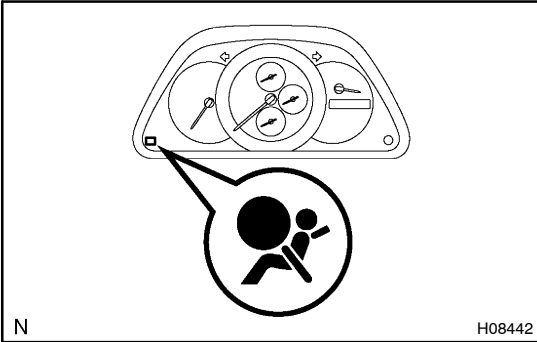

N

H08442

## 6. SRS WARNING LIGHT

The SRS warning light is located on the combination meter. It goes on to alert the driver of trouble in the system when a malfunction is detected in the airbag sensor assembly self-diagnosis. In normal operation conditions when the ignition switch is turned to the ACC or ON position, the light goes on for about 6 seconds and then goes off.

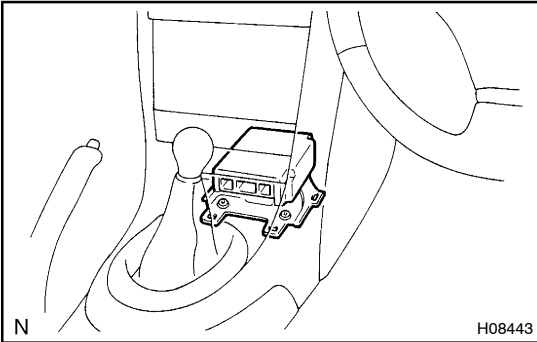

N

H08443

## 7. AIRBAG SENSOR ASSEMBLY

The airbag sensor assembly is mounted on the floor inside the console box. The airbag sensor assembly consists of an airbag sensor, safing sensor, diagnosis circuit, ignition control and drive circuit, etc. It receives signals from the airbag sensor and judges whether the SRS must be activated or not.

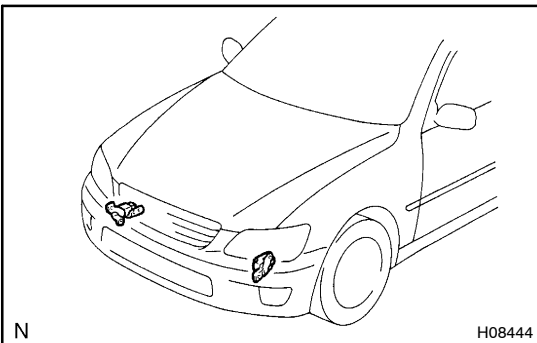

N

H08444

## 8. FRONT AIRBAG SENSOR

The front airbag sensor is mounted inside each of the side members. The sensor unit is a mechanical type. When the sensor detects deceleration force above a predetermined limit, contact is made in the sensor, sending a signal to the airbag sensor assembly. The sensor cannot be disassembled.

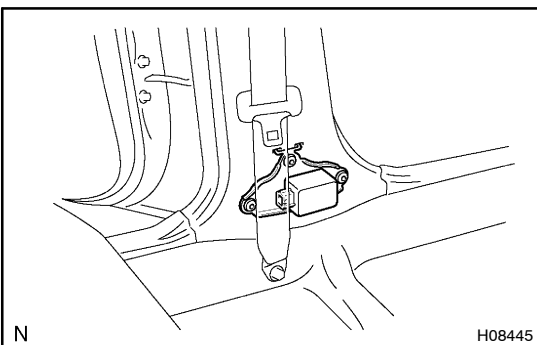

N

H08445

## 9. SIDE AIRBAG SENSOR ASSEMBLY

The side airbag sensor assembly is mounted in the LH and RH center pillars. The side airbag sensor assembly consists of a lateral deceleration sensor, safing sensor and diagnosis circuit, etc. It receives signals to the airbag sensor assembly to judge from the side airbag sensors whether the SRS side airbag must be activated or not.

10. SRS CONNECTORS

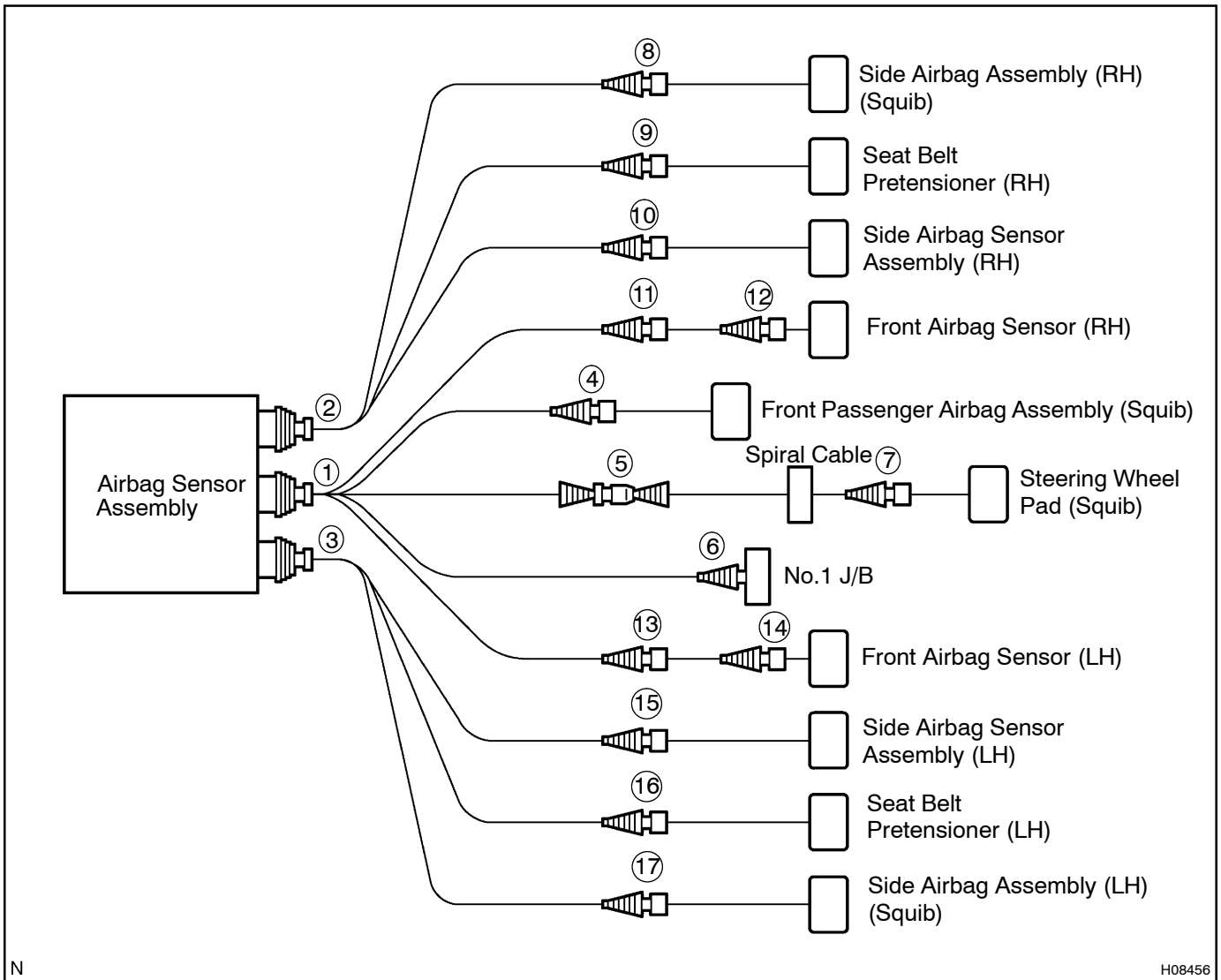

No.	Item	Application
(1)	Terminal Twin-Lock Mechanism	Connectors 1, 2, 3, 4, 5, 6, 7, 8, 9, 10, 11, 12, 13, 14, 15, 16, 17
(2)	Airbag Activation Prevention Mechanism	Connectors 1, 2, 3, 4, 5, 7, 8, 9, 16, 17
(3)	Electrical Connection Check Mechanism	Connectors 1, 2, 3
(4)	Connector Twin-Lock Mechanism	Connectors 5

- (a) All connectors in the SRS are colored in yellow to distinguish them from other connectors. Connectors having special functions and specifically designed for the SRS are used in the locations shown on the previous page to ensure high reliability. These connectors use durable gold-plated terminals.

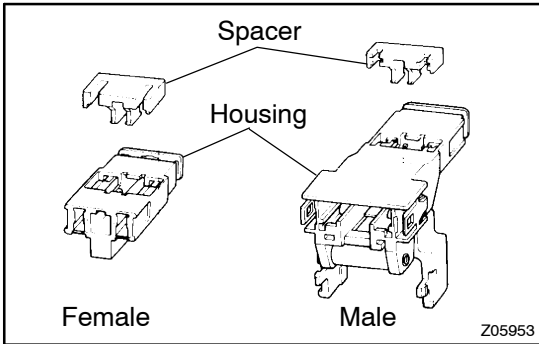

- (1) Terminal twin-lock mechanism:  
Each connector has a two-piece component consisting of a housing and a spacer. This design enables the terminal to be locked securely by 2 locking devices (the retainer and the lance) to prevent terminals from coming out.
- (2) Airbag activation prevention mechanism:  
Each connector contains a short spring plate. When the connector is disconnected, the short spring plate automatically connects positive (+) terminal and negative (-) terminal of the squib.

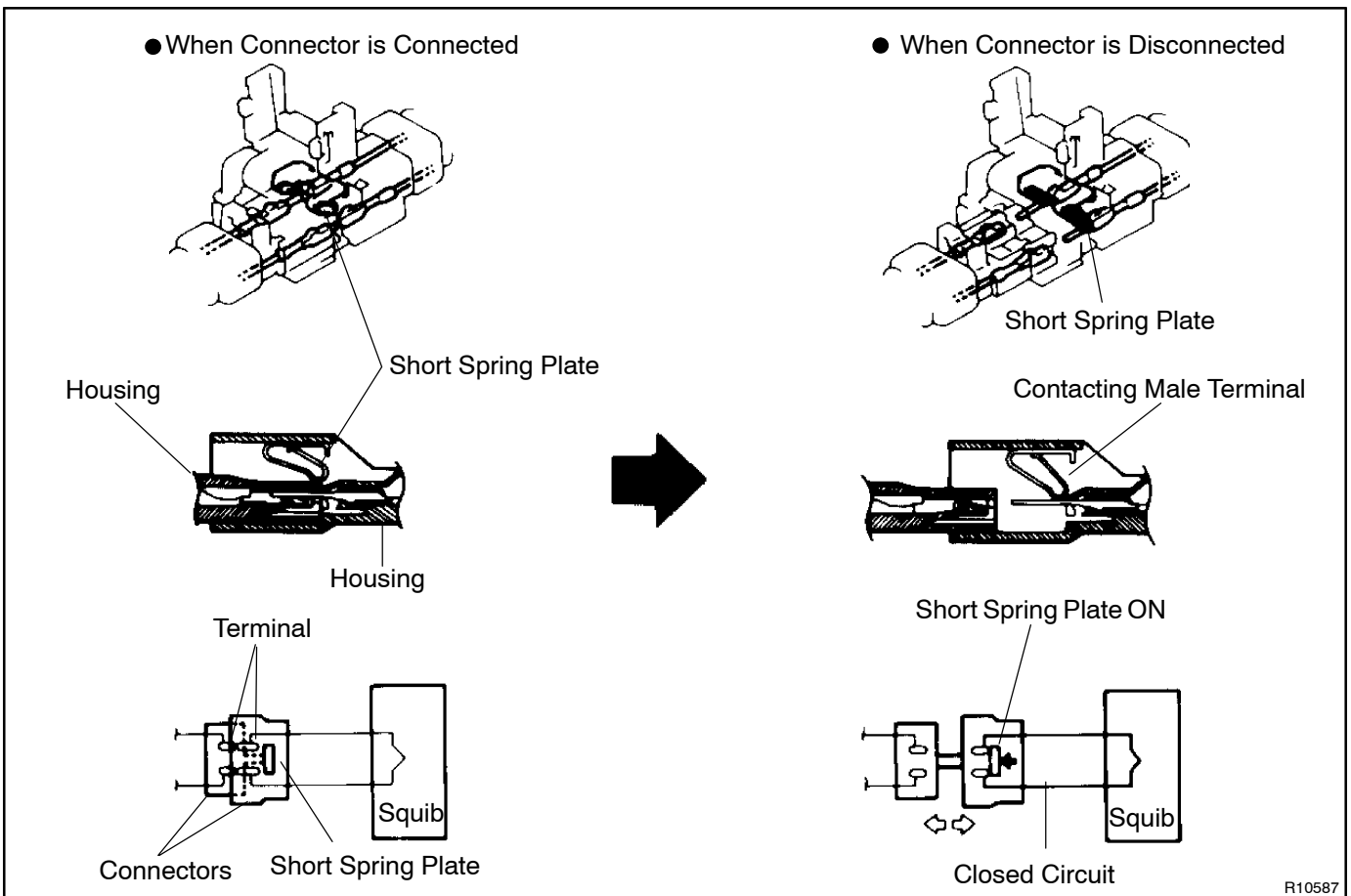

R10587

## HINT:

The type of connector is shown in the diagram on the previous page.

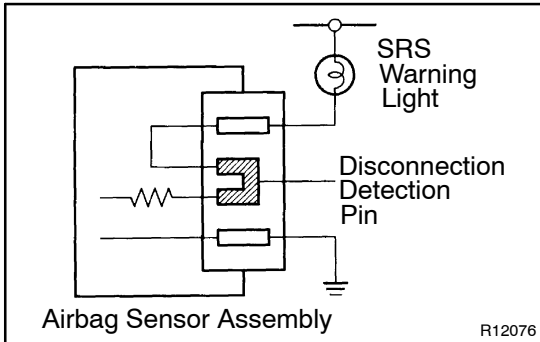

- (3) Electrical connection check mechanism:  
This mechanism electrically checks that connectors are connected correctly and completely. The electrical connection check mechanism is designed so that the disconnection detection pin connects with the diagnosis terminals when the connector housing lock is locked.

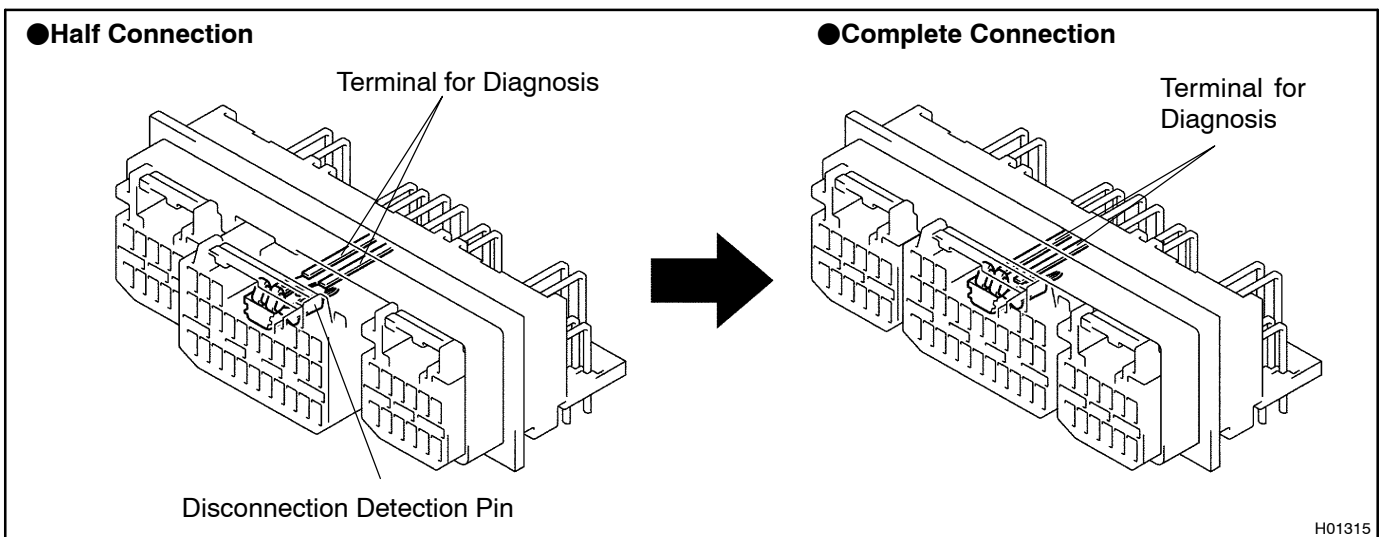

## HINT:

The connectors shown in this illustration are connectors, "1", "2" and "3" in step 10.

- (4) Connector twin-lock mechanism:  
 With this mechanism connectors (male and female connectors) are locked by 2 locking devices to increase the connection reliability. If the primary lock is incomplete, ribs interfere and prevent the secondary lock.

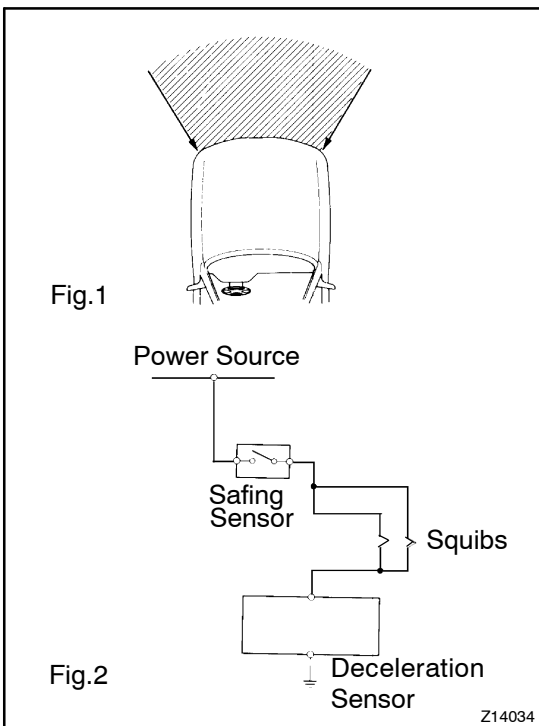
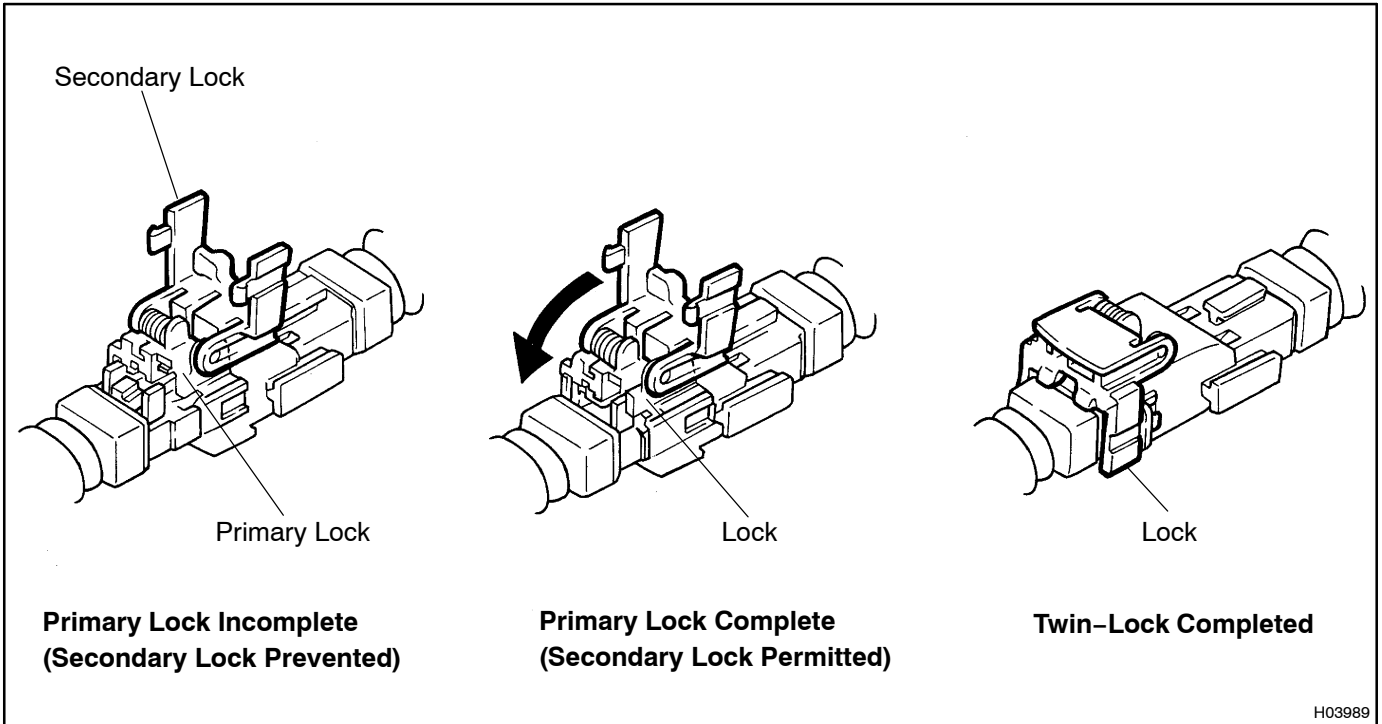

- (b) When the vehicle is involved in a frontal collision in the hatched area (Fig. 1) and the shock is larger than the predetermined level, the SRS is activated automatically. A safing sensor is designed to go on at a smaller deceleration rate than the airbag sensor. As illustrated in Fig. 2, ignition is caused when current flows to the squib, which happens when a safing sensor and the deceleration sensor go on simultaneously. When a deceleration force acts on the sensors, 2 squibs in the driver airbag and front passenger airbag ignite and generate gas. The gas discharging into the driver airbag and front passenger airbag rapidly increases the pressure inside the bags, breaking open the steering wheel pad and instrument panel door. Bag inflation then ends, and the bags deflate as the gas is discharged through discharge holes at the bag's rear or side.

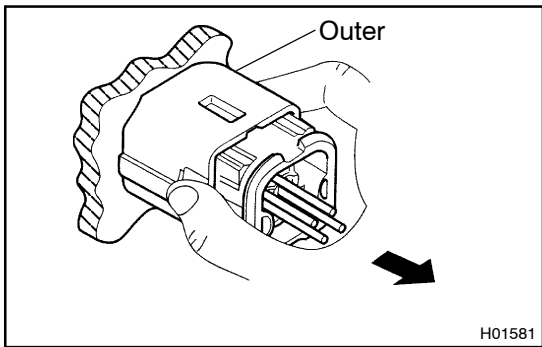

**11. DISCONNECTION OF FRONT AIRBAG SENSOR AND SIDE AIRBAG SENSOR ASSEMBLY CONNECTORS**

- (a) While holding both flank sides of the outer, slide the outer to the direction shown by an arrow.
- (b) Lock of the connectors is released, then disconnect the connectors.

**HINT:**

Be sure to hold both flank sides of the outer. If holding the top and bottom sides, it will obstruct disconnection.

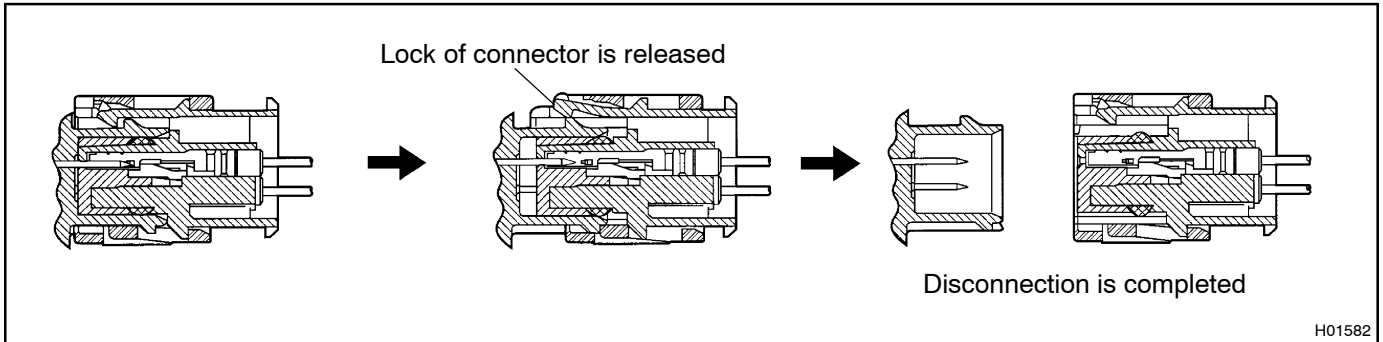

**12. CONNECTION OF FRONT AIRBAG SENSOR AND SIDE AIRBAG SENSOR ASSEMBLY CONNECTORS**

- (a) Align the male connector (of the side of sensor) and female connector in the same direction as shown in the illustration and fit in them without rubbing.
- (b) As they are fitted in, the outer slides rearward. Press it until the outer returns to its original position again.

If fitting stops half way, connectors will separate.

- (c) Be sure to insert until they are locked. After fitting in, pull them slightly to check that they are locked. (When locked, make sure that the outer returns to its original position and sound at the time of fitting in can be heard.)

**HINT:**

- Do not fit in while holding the outer.
- When fitting in, the outer slides. Do not touch it.

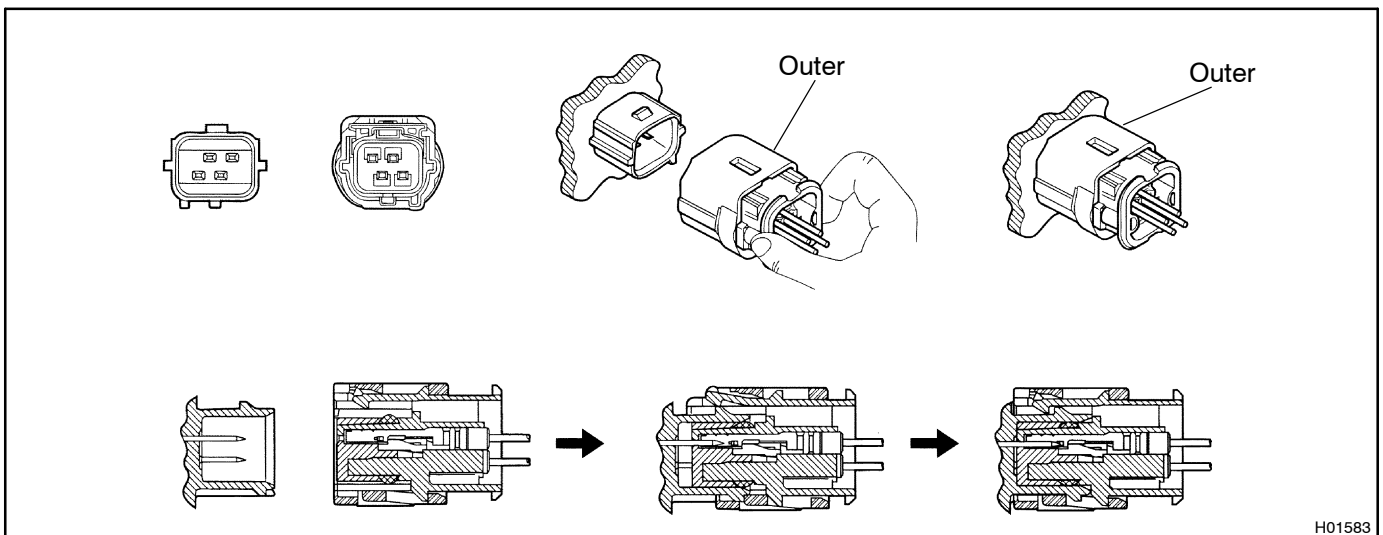

**13. DISCONNECTION OF SIDE AIRBAG CONNECTOR**

- (a) Place a finger on the slider.
- (b) Slide the slider to release lock.
- (c) Disconnect the connector.

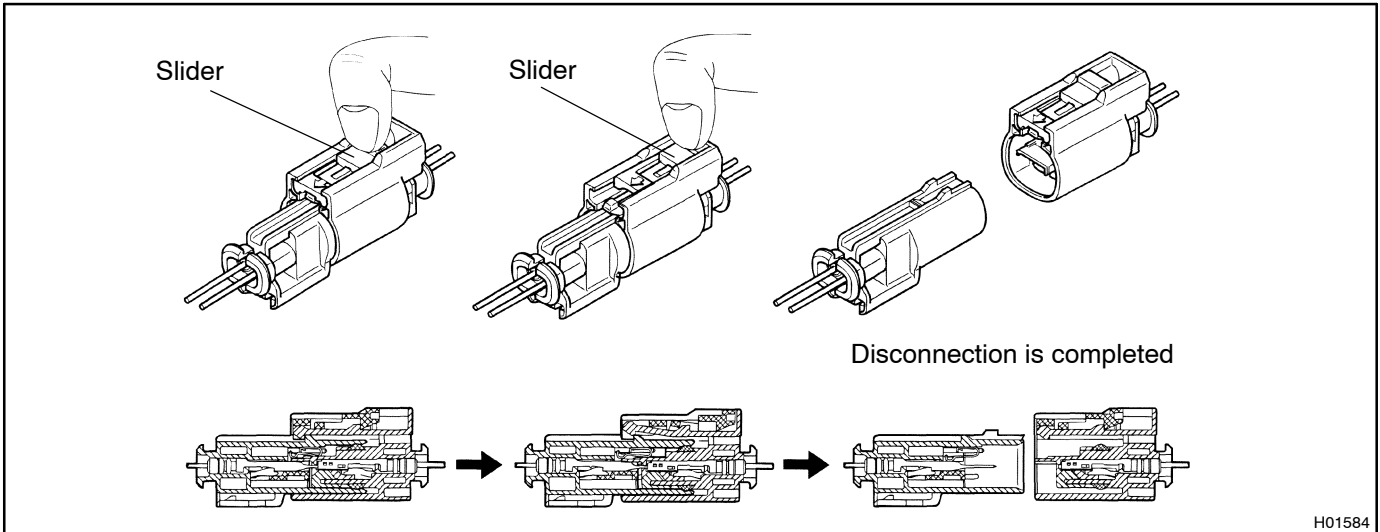



**14. CONNECTION OF SIDE AIRBAG CONNECTOR**

- (a) Align a lock part of male connector and a slider of female connector in the same direction as shown in the illustration, fit in them without rubbing.
- (b) Be sure to insert until they are locked. After fitting in pull them slightly to check that they are locked. (When locked, make sure that the outer returns to its original position and sound at the time of fitting in can be heard.)

**HINT:**

- As the slider slides, do not touch it.
- Be careful not to deform the release board. If the release board is deformed, replace it with a new one.

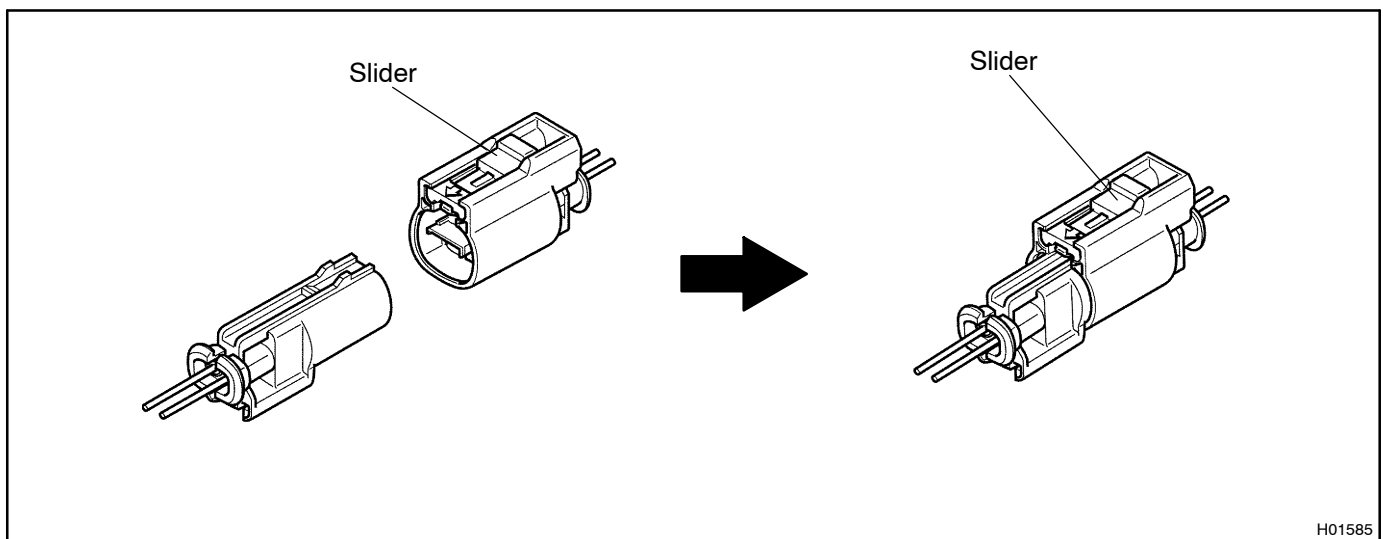

**15. DISCONNECTION OF STEERING WHEEL PAD (with AIRBAG) AND FRONT PASSENGER AIRBAG ASSEMBLY CONNECTORS**

- (a) Place a finger on the slider.
- (b) Slide the slider to release lock.
- (c) Disconnect the connector.

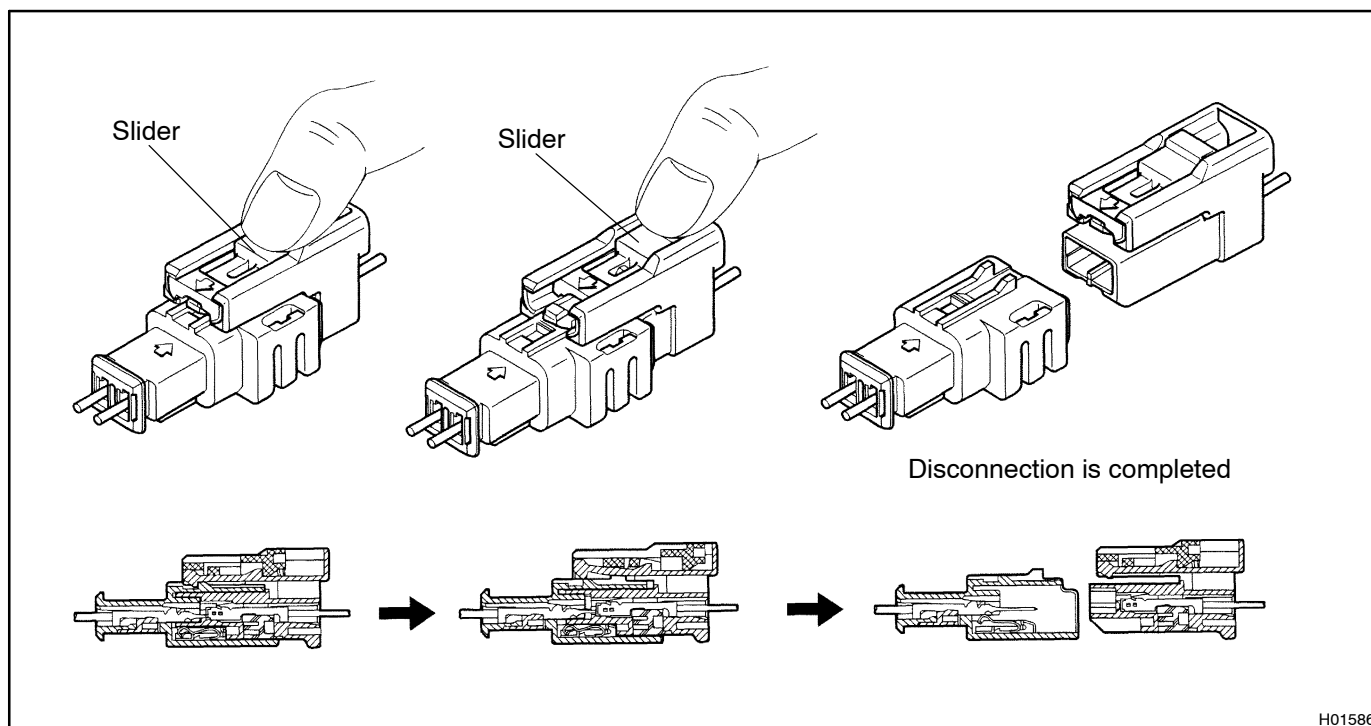

**16. CONNECTION OF STEERING WHEEL PAD (with AIRBAG) AND FRONT PASSENGER AIRBAG ASSEMBLY CONNECTORS**

- (a) Align a lock part of male connector and a slider of female connector in the same direction as shown in the illustration, fit in them without rubbing.
- (b) Be sure to insert until they are locked. After fitting in pull them slightly to check that they are locked. (When locked, make sure that the outer returns to its original position and sound at the time of fitting in can be heard.)

**HINT:**

- As the slider slides, do not touch it.
- Be careful not to deform the release board. If the release board is deformed, replace it with a new one.

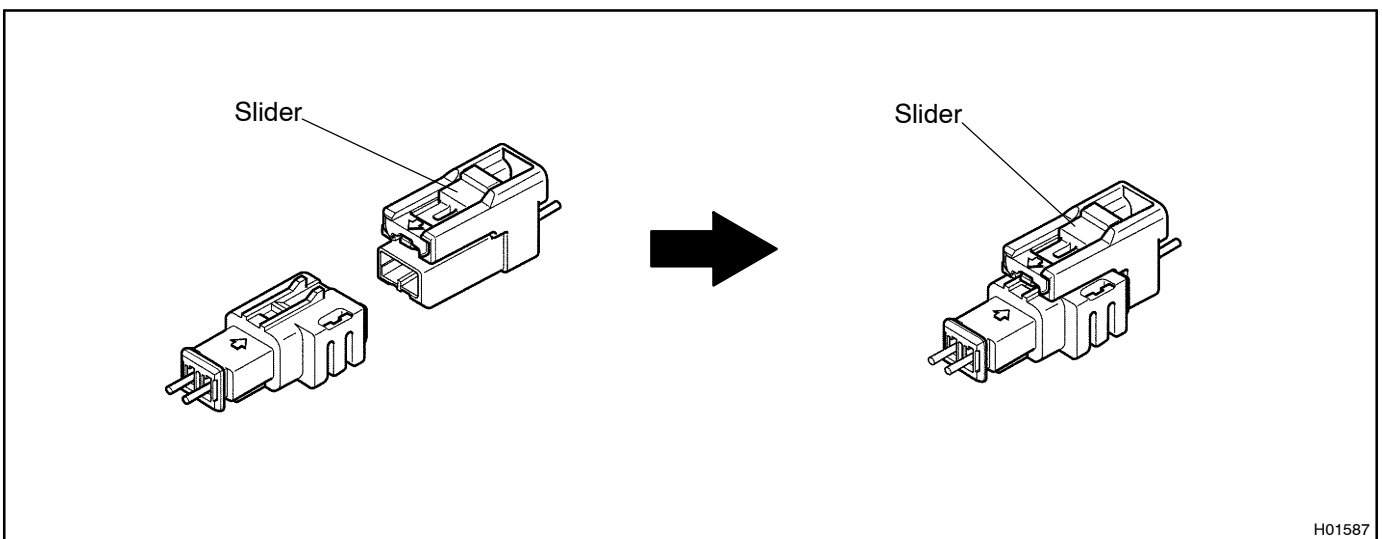

H01587