

INSPECTION

1. INSPECT LOWER BALL JOINT BOOT FOR DAMAGE

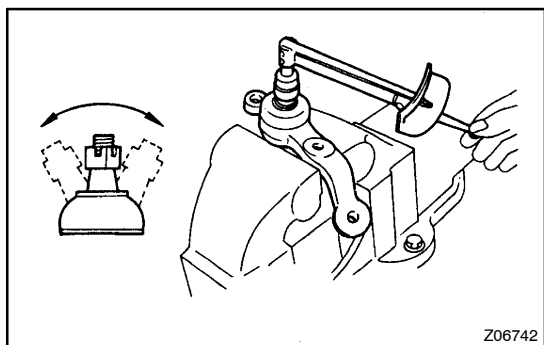

2. INSPECT LOWER BALL JOINT FOR ROTATION CONDITION

- (a) As shown in the illustration, flip the ball joint stud back and forth 5 times, before installing the nut.
- (b) Using torque wrench, turn the nut continuously 1 turn per 2 - 4 seconds and take the torque reading on the 5th turn.

Turning torque:

0.5 - 3.0 N·m (5 - 30 kgf·cm, 0.4 - 26 in·lbf)