

REMOVAL

NOTICE:

- The hub bearing could be damaged if it is subjected to the vehicle weight, such as when moving the vehicle with the drive shaft removed. Therefore, if it is absolutely necessary to place the vehicle weight on the hub bearing, first support it with SST.
- SST 09608-16042 (09608-02021, 09608-02041)
- After disconnecting the drive shaft from the axle hub, work carefully so as not to damage the ABS speed sensor rotor serration on the drive shaft.

1. REMOVE REAR WHEEL

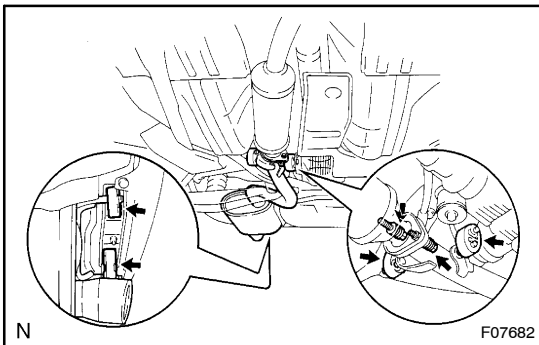

2. RH side:

REMOVE TAILPIPE

- Remove the 2 bolts, springs and disconnect the tailpipe from the center exhaust pipe.
- Disconnect the 4 O-rings from the tailpipe and remove the tailpipe.
- Support the center exhaust pipe securely.
- Remove the gasket.

3. LH side:

REMOVE NO. 1 REAR FLOOR BOARD

4. REMOVE COTTER PIN, LOCK CAP AND LOCK NUT

- Remove the cotter pin and lock cap.
- While depressing the brake pedal, using a socket wrench (32 mm), remove the nut.

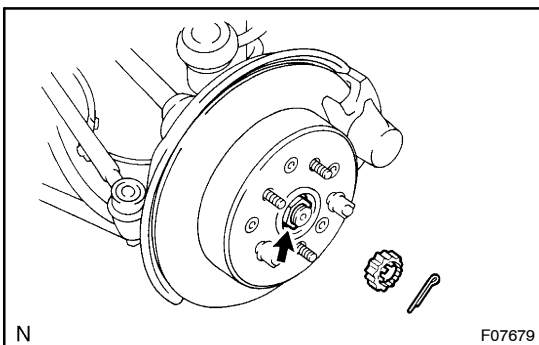

5. REMOVE REAR SUSPENSION MEMBER BRACE

Remove the 2 bolts and suspension member brace.

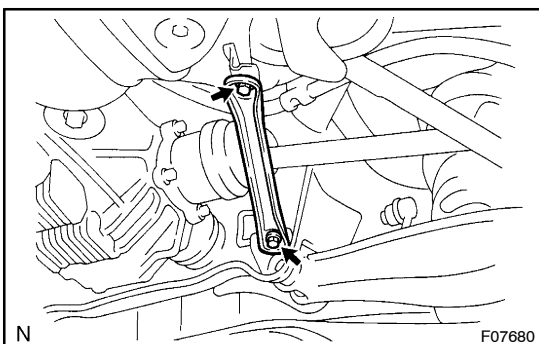

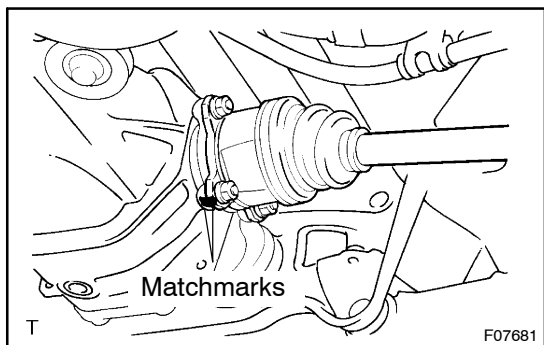

6. REMOVE REAR DRIVE SHAFT

- (a) Place matchmarks on the drive shaft and side gear shaft.

NOTICE:

Do not punch to marks.

- (b) Remove the 4 nuts and washers while depressing the brake pedal.
 (c) Push and compress the inboard joint and disconnect the drive shaft from the side gear shaft.

NOTICE:

Be careful not to damage the boots and end cover.

- (d) Using a brass bar and hammer, lightly tap the end of the drive shaft to disengage the axle hub and remove the drive shaft.

NOTICE:

Be careful not to damage the boots, ABS speed sensor rotor of the drive shaft and oil seal of the axle hub bearing.

