

REMOVAL

1. REMOVE STEERING WHEEL PAD

NOTICE:

If the airbag connector is disconnected with the ignition switch at ON or ACC, DTCs will be recorded.

- (a) Place the front wheels facing straight ahead.
- (b) Using a torx socket wrench, loosen the 2 torx screws until the groove along the screw circumference catches on the screw case.
- (c) Pull out the wheel pad from the steering wheel and disconnect the airbag connector.

CAUTION:

- When storing the wheel pad, keep the upper surface of the pad facing upward.
- Never disassemble the wheel pad.

NOTICE:

When removing the wheel pad, take care not to pull the airbag wire harness.

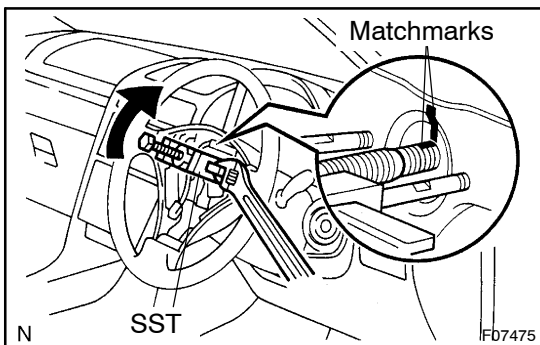
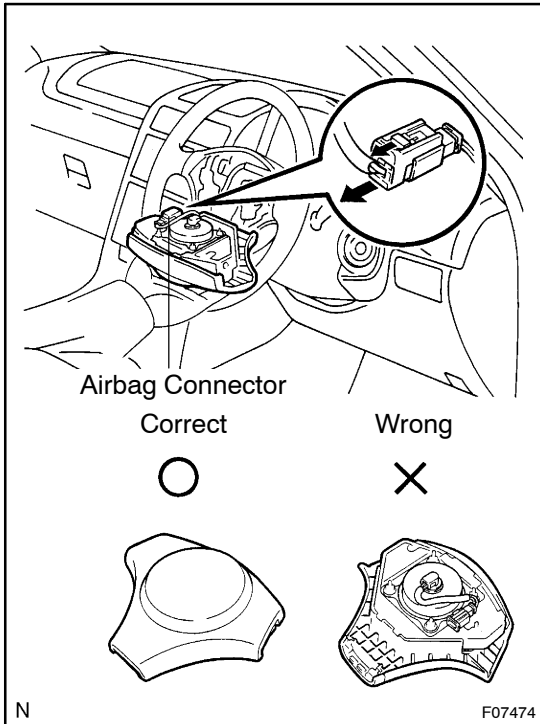

2. REMOVE STEERING WHEEL

- (a) Disconnect the connector.
- (b) Remove the steering wheel set nut.
- (c) Place matchmarks on the steering wheel and main shaft assembly.
- (d) Using SST, remove the wheel.
SST 09950-50012 (09951-05010, 09952-05010, 09953-05020, 09954-05020)

3. REMOVE FRONT DOOR INSIDE SCUFF PLATE AND COWL SIDE TRIM BOARD

- (a) Remove the front door inside scuff plate.
- (b) Remove the clip and cowl side trim board.

4. REMOVE LOWER FINISH PANEL

- (a) Remove the 3 screws.
- (b) Disconnect the connectors and remove the lower finish panel.
- (c) Disconnect the hood lock control cable.

5. REMOVE CLUSTER FINISH PANEL

- (a) Remove the 2 screws.
- (b) Disconnect the connector and remove the cluster finish panel.

6. REMOVE COLUMN UPPER AND LOWER COVERS

- (a) Remove the 3 screws and column lower cover.
- (b) Remove the column upper cover.

7. REMOVE COMBINATION SWITCH WITH SPIRAL CABLE

- (a) Disconnect the connectors.
- (b) Disconnect the airbag connector.
- (c) Remove the 3 screws and combination switch.

8. REMOVE SPIRAL CABLE (See page BE-26)**NOTICE:**

Do not disassemble the cable or apply oil to it.

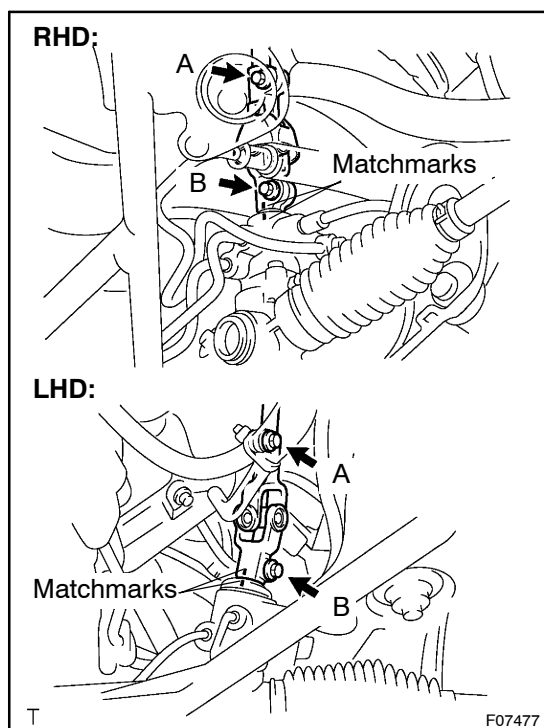
**9. DISCONNECT SLIDING YOKE**

- (a) Place matchmarks on the sliding yoke and control valve shaft.
- (b) Loosen the bolt A and remove the bolt B.

10. REMOVE STEERING COLUMN ASSEMBLY

- (a) Loosen the clamp.
- (b) Disconnect the connectors.
- (c) Remove the 4 nuts and steering column assembly.

11. REMOVE SLIDING YOKE

Remove the bolt A and sliding yoke.

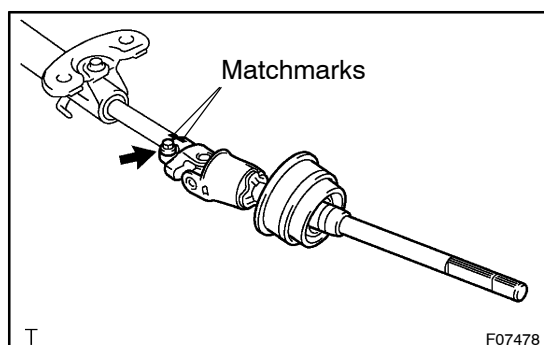
**12. REMOVE NO. 2 INTERMEDIATE SHAFT ASSEMBLY**

- (a) Place matchmarks on the No. 2 intermediate shaft assembly and main shaft.
- (b) Remove the bolt and No. 2 intermediate shaft assembly.