

INSTALLATION

1. INSTALL NO. 2 INTERMEDIATE SHAFT ASSEMBLY

- Align the matchmarks on the No. 2 intermediate shaft assembly and main shaft.
- Install the No. 2 intermediate shaft assembly with the bolt.
Torque: 35 N·m (360 kgf·cm, 26 ft·lbf)

2. INSTALL SLIDING YOKE

Temporarily install the sliding yoke with the bolt A.

3. INSTALL STEERING COLUMN ASSEMBLY

- Install the steering column assembly with the 4 nuts.
Torque: 26 N·m (260 kgf·cm, 19 ft·lbf)
- Connect the connectors.
- Tighten the clamp.

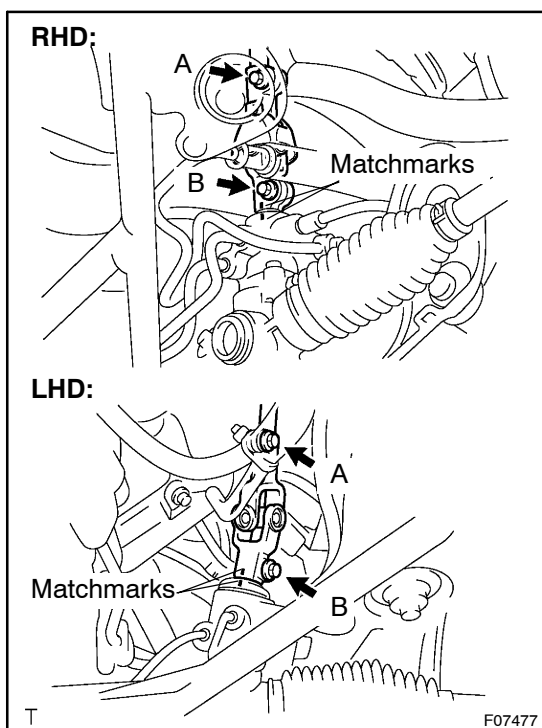

4. CONNECT SLIDING YOKE

- Align the matchmarks on the sliding yoke and control valve shaft.
- Install the bolt B.
Torque: 35 N·m (360 kgf·cm, 26 ft·lbf)
- Torque the bolt A.
Torque: 35 N·m (360 kgf·cm, 26 ft·lbf)

5. INSTALL SPIRAL CABLE (See page BE-26)

6. INSTALL COMBINATION SWITCH WITH SPIRAL CABLE

- Install the combination switch with the 3 screws.
- Connect the airbag connector.
- Connect the connectors.

7. INSTALL COLUMN UPPER AND LOWER COVERS

- Install the column upper cover.
- Install the column lower cover with the 3 screws.

8. INSTALL CLUSTER FINISH PANEL

- Connect the connector and install the cluster finish panel.
- Install the 2 screws.

9. INSTALL LOWER FINISH PANEL

- Connect the hood lock control cable to the lower finish panel.
- Connect the connectors and install the lower finish panel.
- Install the 3 screws.

10. INSTALL FRONT DOOR INSIDE SCUFF PLATE AND COWL SIDE TRIM BOARD

- (a) Install the cowl side trim board with the clip.
- (b) Install the front door inside scuff plate.

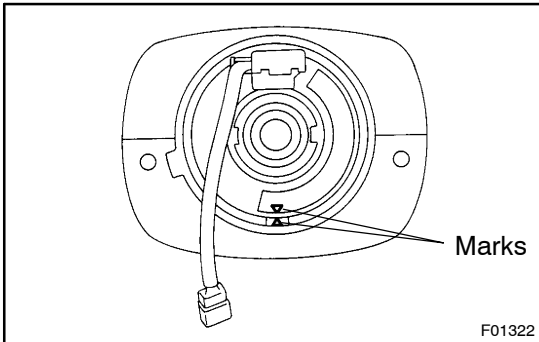
**11. CENTER SPIRAL CABLE**

- (a) Check that the front wheels are facing straight ahead.
- (b) Turn the cable counterclockwise by hand until it becomes harder to turn.
- (c) Then rotate the cable clockwise about 2.5 turns to align the marks.

HINT:

The cable will rotate about 2.5 turns to either left or right of the center.

12. INSTALL STEERING WHEEL

- (a) Align the matchmarks on the steering wheel and main shaft assembly.

- (b) Install the steering wheel set nut.

Torque: 35 N·m (360 kgf·cm, 26 ft·lbf)

- (c) Connect the connector.

13. INSTALL STEERING WHEEL PAD**NOTICE:**

- **Never use airbag parts from another vehicle. When replacing parts, replace with new ones.**
- **Make sure the wheel pad is installed with the specified torque.**
- **If the wheel pad has been dropped, or there are cracks, dents or other defects on the case or connector, replace the wheel pad with a new one.**
- **When installing the wheel pad, take care that the wirings do not interfere with other parts and that they are not pinched between other parts.**

- (a) Connect the airbag connector.

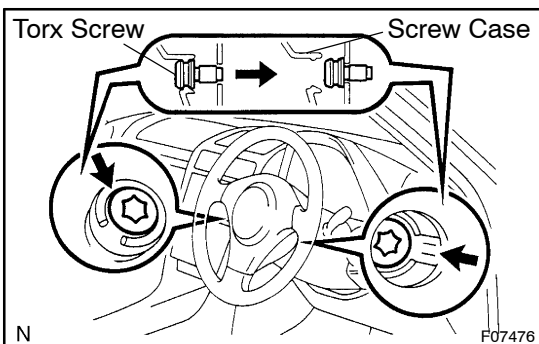

- (b) Install the steering wheel pad after confirming that the circumference groove of the torx screws is caught on the screw case.

- (c) Using a torx socket wrench, torque the 2 screws.

Torque: 8.8 N·m (90 kgf·cm, 78 in·lbf)

14. CHECK STEERING WHEEL CENTER POINT