

REASSEMBLY

NOTICE:

When using a vise, do not overtighten it.

1. COAT PARTS INDICATED BY ARROWS WITH POWER STEERING FLUID OR MOLYBDENUM DISULFIDE LITHIUM BASE GREASE (See page SR-38)

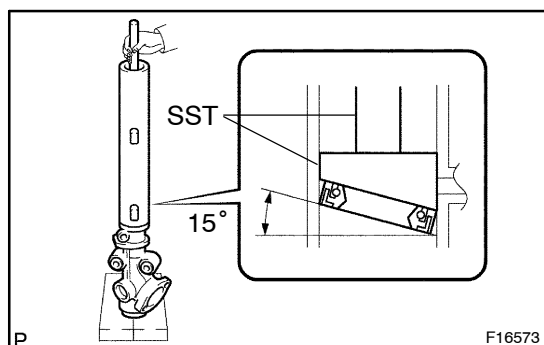

2. INSTALL OIL SEAL

- (a) Apply power steering fluid to a new oil seal, and install the oil seal on the rack housing at an angle.

NOTICE:

Install the oil seal in the correct direction.

HINT:

Install the oil seal so that the port faces downward with approx. 15 degrees.

- (b) Using SST, push in the oil seal by hand until it passes through the 2 ports.

SST 09631-00180, 09950-70010 (09951-07360)

NOTICE:

Do not turn SST when inserting the oil seal.

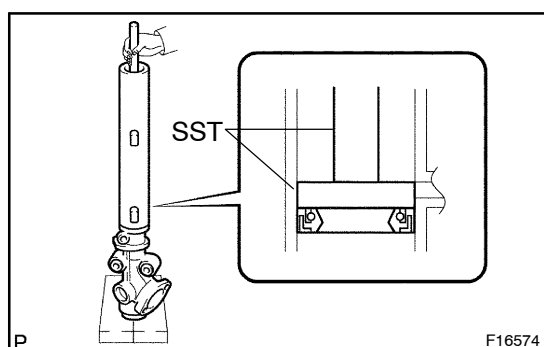

- (c) After the oil seal has passed through the ports, push in the oil seal by hand until it becomes level, using SST.

SST 09950-60010 (09951-00430), 09950-70010 (09951-07360)

NOTICE:

When SST is set, do not damage the inside surface of the rack housing.

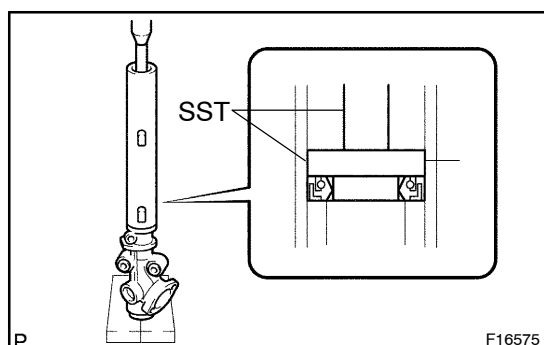

- (d) After the oil seal has become level, using SST and press, install the oil seal.

SST 09950-60010 (09951-00430), 09950-70010 (09951-07360)

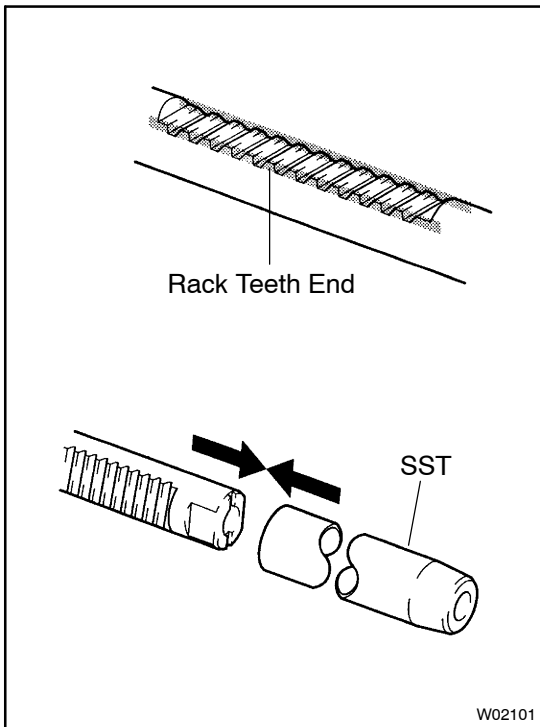

3. INSTALL STEERING RACK

- (a) Install SST to the rack.
SST 09631-33010

HINT:

If necessary, scrape the burrs off the rack teeth end and bur-nish.

- (b) Coat SST with power steering fluid.
- (c) Install the steering rack into the rack housing.
- (d) Remove the SST.
SST 09631-33010

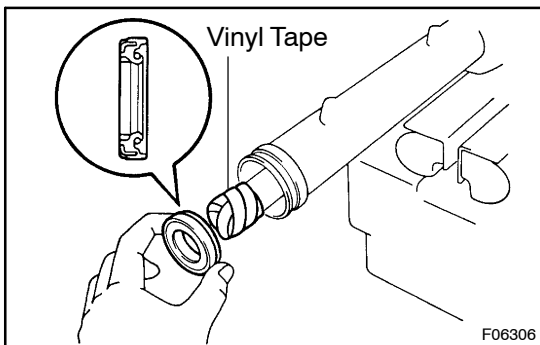

4. INSTALL OIL SEAL

- (a) Coat a new oil seal lip with power steering fluid.
- (b) To prevent oil seal lip damage, wind vinyl tape on the steering rack end, and apply power steering fluid.
- (c) Install the oil seal by pushing it into the rack housing without tilting.

NOTICE:

Make sure that the oil seal is installed facing in the correct direction.

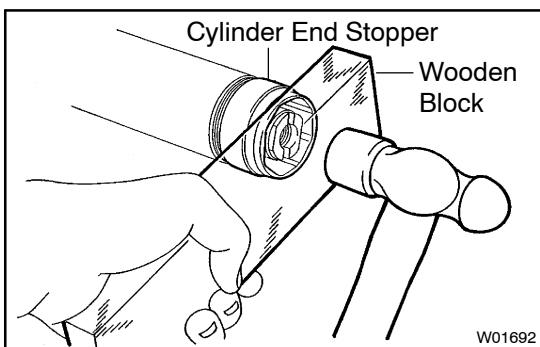

5. INSTALL CYLINDER END STOPPER AND SPACER

- (a) Install the spacer.
- (b) Coat a new O-ring with power steering fluid and install it to the cylinder end stopper.
- (c) Using a wooden block and hammer, drive in the cylinder end stopper until it is tightly installed.

NOTICE:

Be careful not to damage the O-ring.

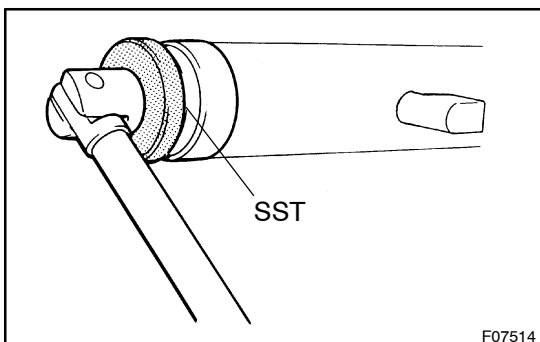

- (d) Using SST, torque the cylinder end stopper.

SST 09631-20090

Torque: 59 N·m (600 kgf·cm, 44 ft·lbf)

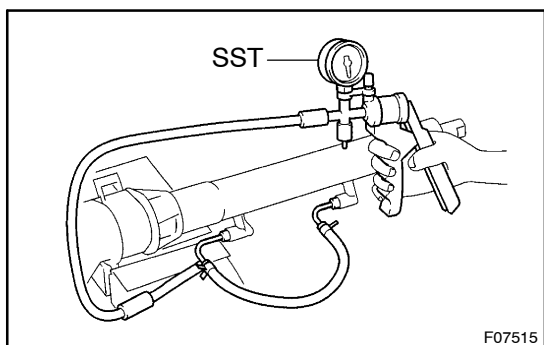
**6. AIR TIGHTNESS TEST**

- (a) Install SST to the rack housing.
SST 09631-12071
- (b) Apply 53 kPa (400 mmHg, 15.75 in.Hg) of vacuum for about 30 seconds.
- (c) Check that there is no change in the vacuum.
If there is a change in the vacuum, check the installation of the oil seals.

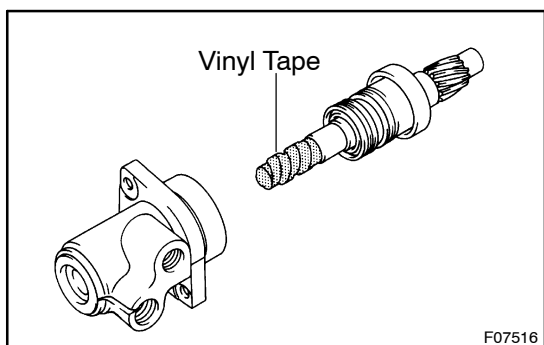
**7. INSTALL CONTROL VALVE ASSEMBLY**

- (a) Coat the teflon rings with power steering fluid.
- (b) To prevent oil seal lip damage, wind vinyl tape on the serrated part of the control valve shaft.
- (c) Push the control valve assembly into the control valve housing.

NOTICE:

Be careful not to damage the teflon rings and oil seal lip.

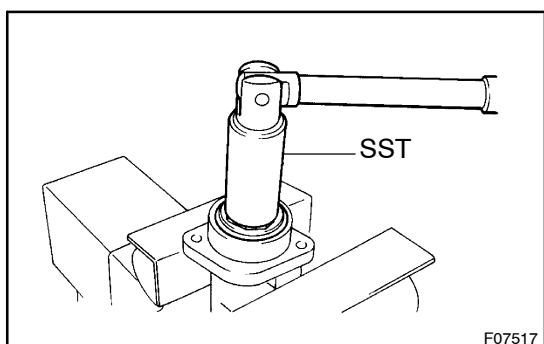
**8. INSTALL BEARING GUIDE NUT**

- (a) Coat a new O-ring with power steering fluid, and install it to the bearing guide nut.
- (b) Using SST, install the bearing guide nut.
SST 09631-20060
Torque: 25 N·m (250 kgf·cm, 18 ft·lbf)

NOTICE:

Be careful not to damage the oil seal lip.

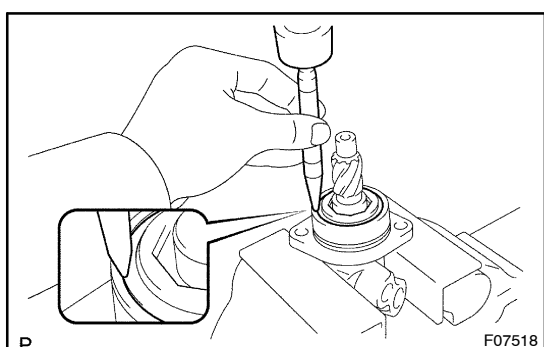

- (c) Using a punch, stake the bearing guide nut.

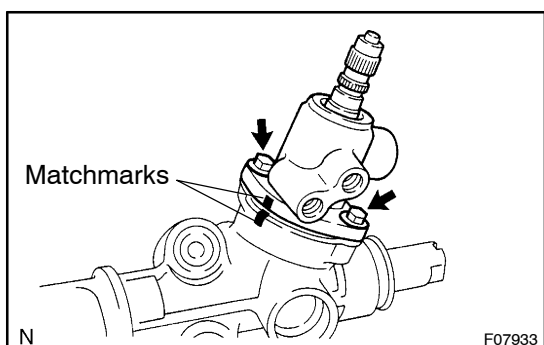
**9. INSTALL CONTROL VALVE HOUSING WITH CONTROL VALVE ASSEMBLY**

- (a) Coat a new O-ring with power steering fluid, and install it to the control valve housing.
- (b) Align the matchmarks on the valve housing and rack housing.
- (c) Install the 2 bolts.
Torque: 18 N·m (185 kgf·cm, 13 ft·lbf)

10. INSTALL DUST COVER

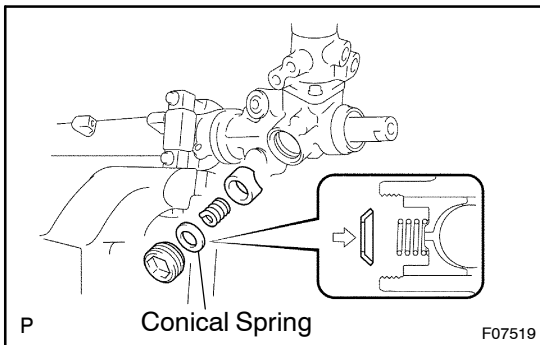

11. INSTALL RACK GUIDE SUB-ASSEMBLY, RACK GUIDE SPRING, CONICAL SPRING AND RACK GUIDE SPRING CAP

- (a) Install the rack guide sub-assembly, rack guide spring and conical spring.

NOTICE:

Make sure that the conical spring is installed facing in the correct direction.

- (b) Apply sealant to 2 or 3 threads of the rack guide spring cap.

Sealant:

Part No.08833-00080, THREE BOND 1344, LOCTITE 242 or equivalent

- (c) Temporarily install the rack guide spring cap.

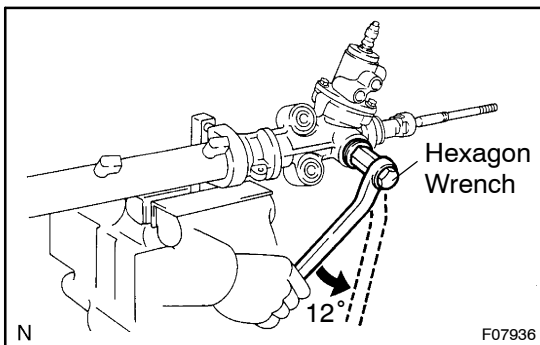

12. ADJUST TOTAL PRELOAD

- (a) To prevent the steering rack teeth from damaging the oil seal lip, temporarily install the RH and LH rack ends.

- (b) Using a hexagon wrench (24 mm), torque the rack guide spring cap.

Torque: 25 N·m (250 kgf·cm, 18 ft·lbf)

- (c) Using a hexagon wrench (24 mm), return the rack guide spring cap 12°.

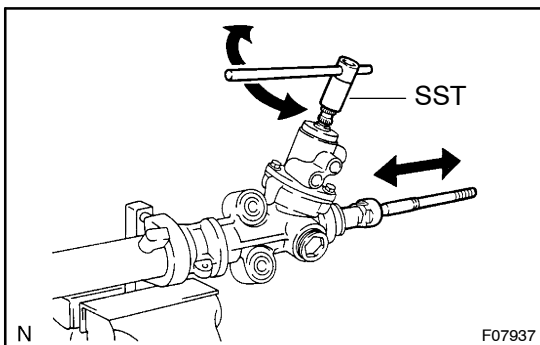

- (d) Using SST, turn the control valve shaft right and left 1 or 2 times.

SST 09616-00010

- (e) Using a hexagon wrench (24 mm), loosen the rack guide spring cap until the rack guide spring is not functioning.

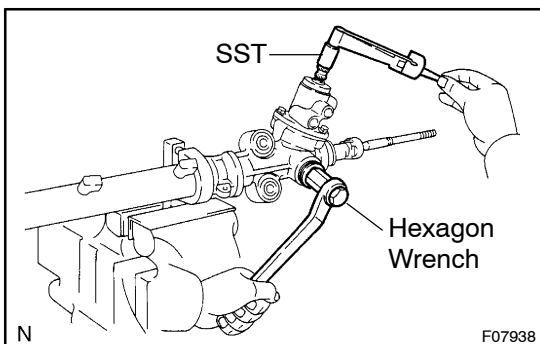

- (f) Using SST, a torque wrench and hexagon wrench (24 mm), tighten the rack guide spring cap until the preload is within the specification.

SST 09616-00010

Preload (turning):

1.15 - 1.95 N·m (11.7 - 19.9 kgf·cm, 10.2 - 17.3 in·lbf)

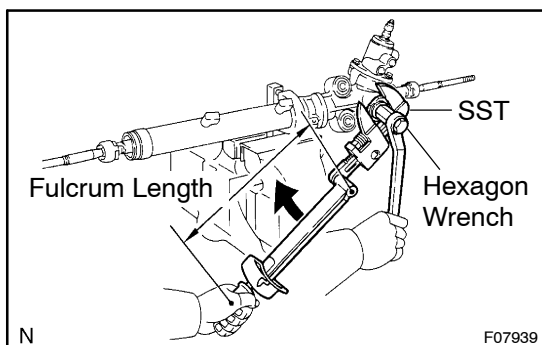
**13. INSTALL RACK GUIDE SPRING CAP LOCK NUT**

- (a) Apply sealant to 2 or 3 threads of the rack guide spring cap lock nut.

Sealant:

**Part No.08833-00080, THREE BOND 1344,
LOCTITE 242 or equivalent**

- (b) Temporarily install the rack guide spring cap lock nut.
(c) Using a hexagon wrench (24 mm), hold the rack guide spring cap and using SST, torque the rack guide spring cap lock nut.

SST 09922-10010

Torque: 50 N·m (513 kgf·cm, 37 ft·lbf)

NOTICE:

Use SST 09922-10010 in the direction shown in the illustration.

HINT:

Use a torque wrench with a fulcrum length of 345 mm (13.58 in.).

- (d) Recheck the total preload.

Preload (turning):

1.15 - 1.95 N·m (11.7 - 19.9 kgf·cm, 10.2 - 17.3 in·lbf)

- (e) Remove the RH and LH rack ends.

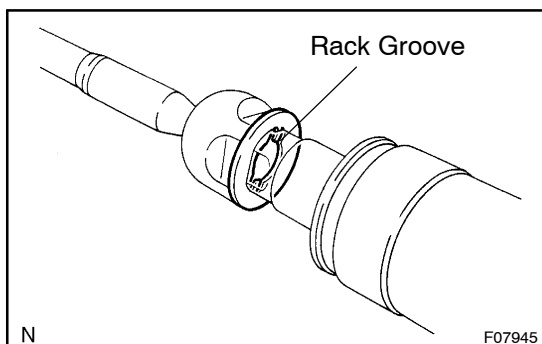
**14. INSTALL RH AND LH CLAW WASHERS AND RACK ENDS**

- (a) Install a new claw washer, and temporarily install the rack end.

HINT:

Align the claws of the claw washer with the steering rack grooves.

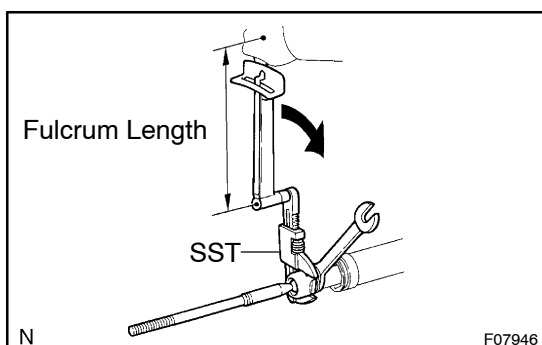

- (b) Using a spanner, hold the steering rack steadily and using SST, torque the rack end.

SST 09922-10010

Torque: 76 N·m (780 kgf·cm, 56 ft·lbf)

NOTICE:

Use SST 09922-10010 in the direction shown in the illustration.

HINT:

Use a torque wrench with a fulcrum length of 380 mm (14.96 in.).

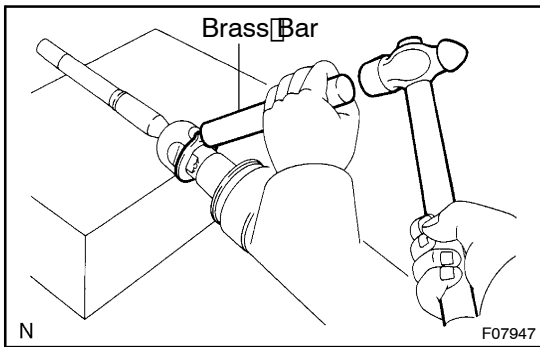

(c) Using a brass bar and a hammer, stake the washer.

NOTICE:

Avoid any impact on the steering rack.

(d) Employ the same manner described above to the other side.

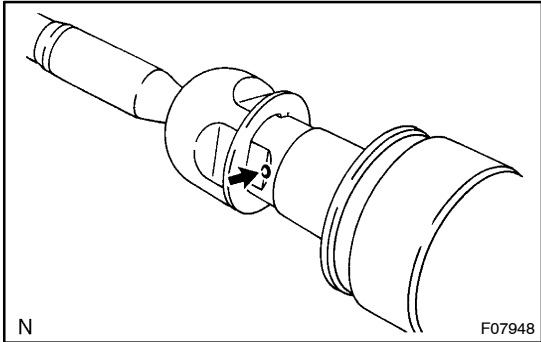

15. INSTALL RH AND LH RACK BOOTS, CLAMPS AND CLIPS

(a) Ensure that the steering rack hole is not clogged with grease.

HINT:

If the hole is clogged, the pressure inside the boot will change after it is assembled and the steering wheel is turned.

(b) Install the boot, clip and a new clamp.

NOTICE:

Be careful not to damage or twist the boot.

(c) Tighten the clamp as shown in the illustration.

(d) Employ the same manner described above to the other side.

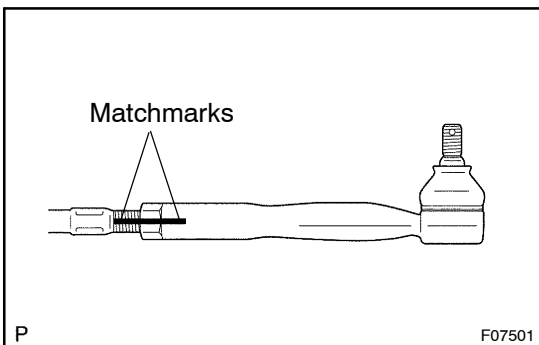
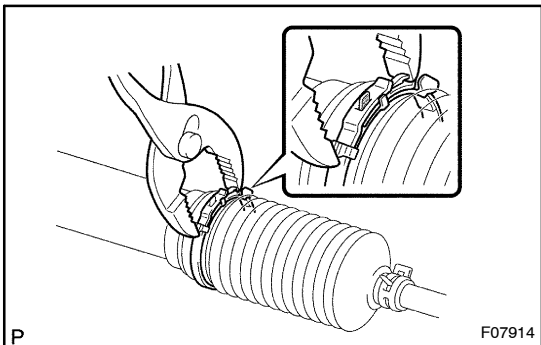

16. INSTALL RH AND LH TIE ROD ENDS AND LOCK NUTS

(a) Screw the lock nut and tie rod end onto the rack end until the matchmarks are aligned.

(b) After adjusting toe-in, torque the nut
(See page SA-5)

Torque: 56 N·m (570 kgf·cm, 41 ft·lbf)

(c) Employ the same manner described above to the other side.

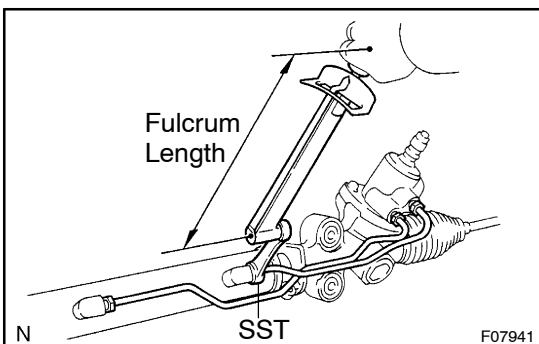

17. INSTALL 2-TURN PRESSURE TUBES

Using SST, install the 2 turn pressure tubes.

SST 09633-00020

Torque: 20 N·m (203 kgf·cm, 15 ft·lbf)

HINT:

- Use a torque wrench with a fulcrum length of 300 mm (11.81 in.).
- This torque value is effective in case that SST is parallel to a torque wrench.