

## INSPECTION

### 1. INSPECT ARMATURE COIL

- (a) Check the commutator for open circuit.  
Using an ohmmeter, check that there is continuity between the segments of the commutator.

If there is no continuity between any segments, replace the armature.

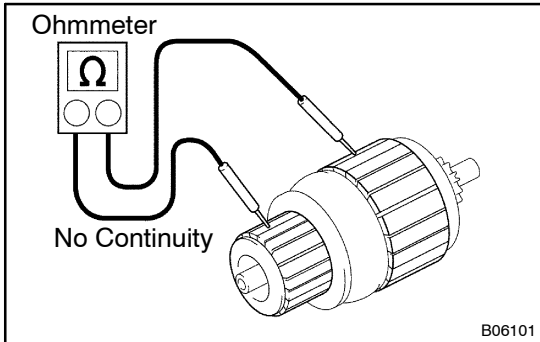

- (b) Check the commutator for ground.  
Using an ohmmeter, check that there is no continuity between the commutator and armature coil core.

If there is continuity, replace the armature.

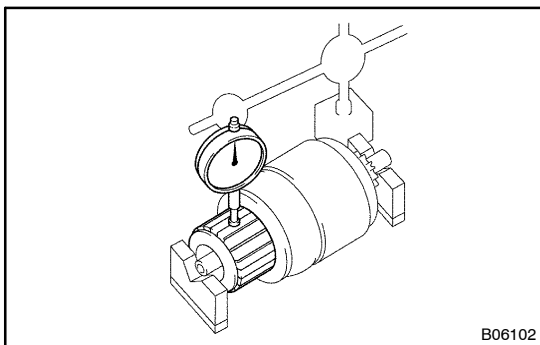

### 2. INSPECT COMMUTATOR

- (a) Check the commutator for the dirty and burnt surface.  
If the surface is dirty or burnt, correct with sandpaper (No.400) or a lathe.

- (b) Check for the commutator circuit runout.  
(1) Place the commutator on V-blocks.  
(2) Using a dial indicator, measure the circle runout.

**Maximum circle runout: 0.05 mm (0.0020 in.)**

If the circle runout is greater than maximum, correct it on a lathe.

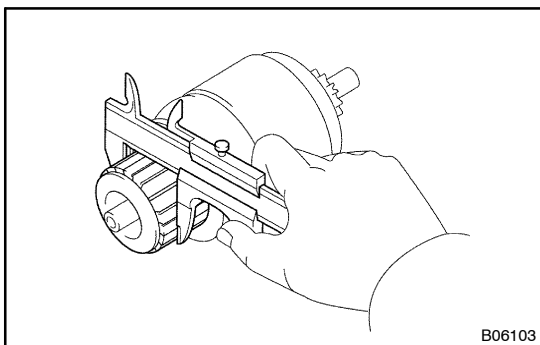

- (c) Using vernier calipers, measure the commutator diameter.

**Standard diameter: 28.0 mm (1.102 in.)**

**Minimum diameter: 27.0 mm (1.063 in.)**

If the diameter is less than minimum, replace the armature.

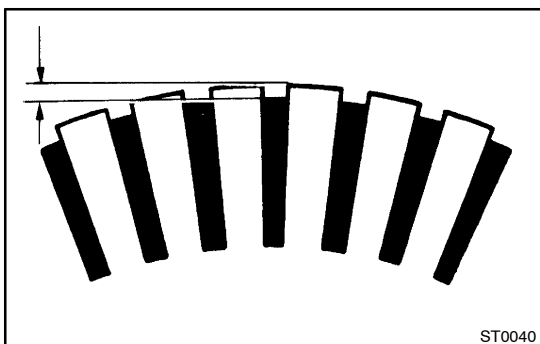

- (d) Check that the undercut depth is clean and free of foreign materials. Smooth out the edge.

**Standard undercut depth: 0.6 mm (0.024 in.)**

**Minimum undercut depth: 0.2 mm (0.008 in.)**

If the undercut depth is less than minimum, correct it with a hacksaw blade.

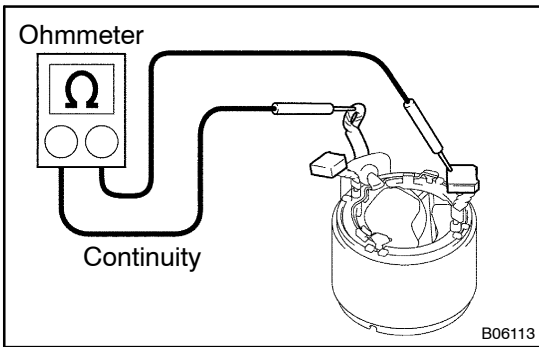

### 3. INSPECT FIELD COIL (FIELD FRAME)

- (a) Check the field coil for open circuit.  
Using an ohmmeter, check that there is continuity between the lead wire and field coil brush lead.  
If there is no continuity, replace the field frame.

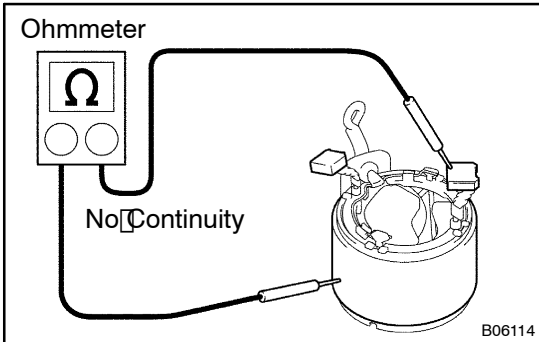

- (b) Check the field coil for ground.  
Using an ohmmeter, check that there is no continuity between the field coil end and field frame.  
If there is continuity, repair or replace the field frame.

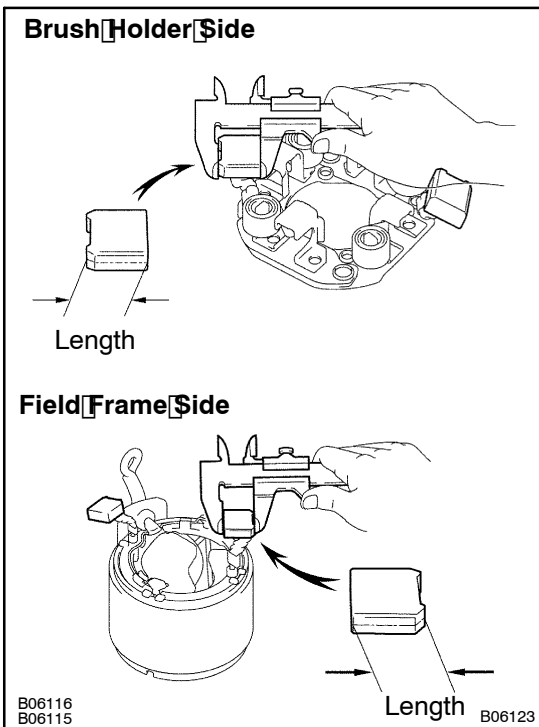

### 4. INSPECT BRUSH LENGTH

Using vernier calipers, measure the brush length.

**Standard length: 14.0 mm (0.551 in.)**

**Minimum length: 9.0 mm (0.354 in.)**

If the length is less than minimum, replace the brush (field frame side) (see page ST-10) or brush holder, and dress with an emery cloth.

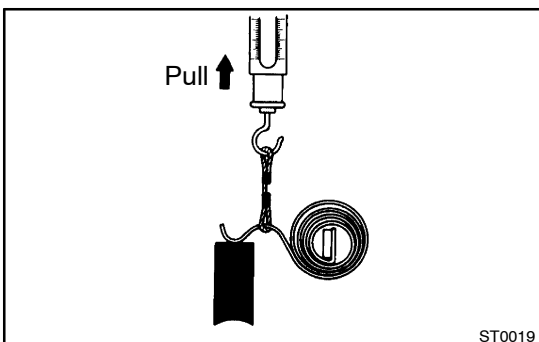

### 5. INSPECT BRUSH SPRINGS

Check the brush spring load. Take the pull scale reading the instant the brush spring separates from the brush.

**Standard spring installed load:**

**13.7 – 17.6 N (1.4 – 1.8 kgf, 3.1 – 4.0 lbf)**

**Minimum spring installed load:**

**8.8 N (0.9 kgf, 2.0 lbf)**

If the installed load is less than minimum, replace the brush springs.

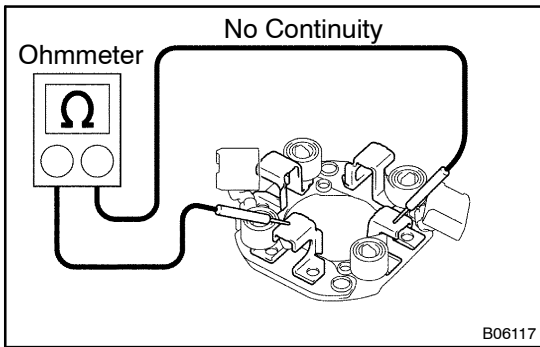

## 6. INSPECT BRUSH HOLDER

Check the brush holder insulator.

Using an ohmmeter, check that there is no continuity between the positive (+) and negative (-) brush holders.

If there is continuity, repair or replace the brush holder.

## 7. INSPECT CLUTCH AND GEAR

(a) Check the gear teeth on the planetary gear, internal gear and starter clutch for wear or damage.

If the gear is damaged, replace it.

If damaged, replace the gear or clutch assembly. If damaged, also check the drive plate ring gear for wear or damage.

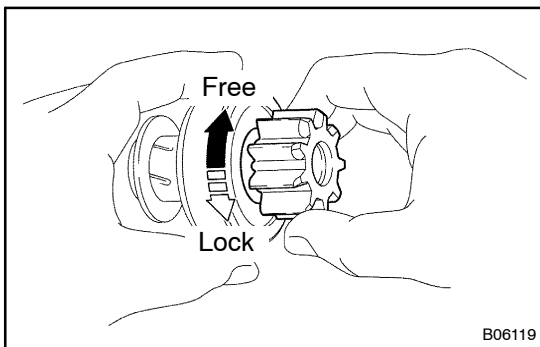

(b) Check the starter clutch.

Rotate the clutch pinion gear clockwise and check that it turns freely. Try to rotate the clutch pinion gear counter-clockwise and check that it locks.

If necessary, replace the starter clutch.

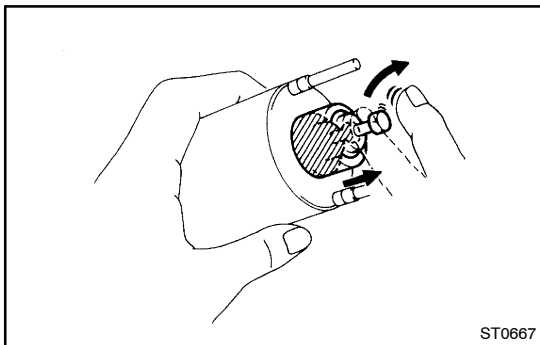

## 8. INSPECT MAGNETIC SWITCH

(a) Check the plunger.

Push in the plunger and check that it returns quickly to its original position.

If necessary, replace the magnetic switch.

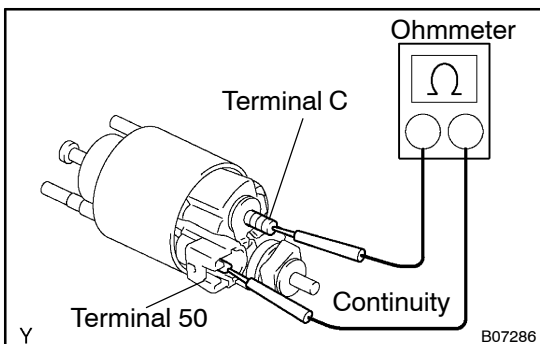

(b) Check the pull-in coil for open circuit.

Using an ohmmeter, check that there is continuity between terminals 50 and C.

If there is no continuity, replace the magnetic switch.

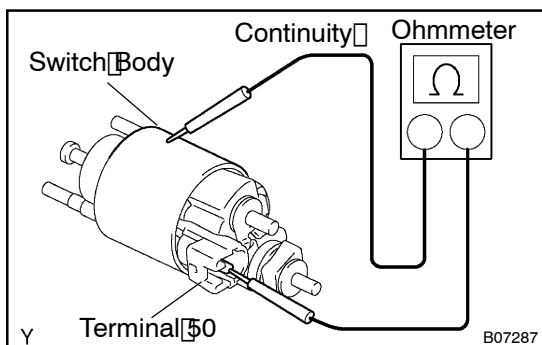

- (c) Check the hold-in coil for open circuit. Using an ohmmeter, check that there is continuity between terminal 50 and the switch body. If there is no continuity, replace the magnetic switch.

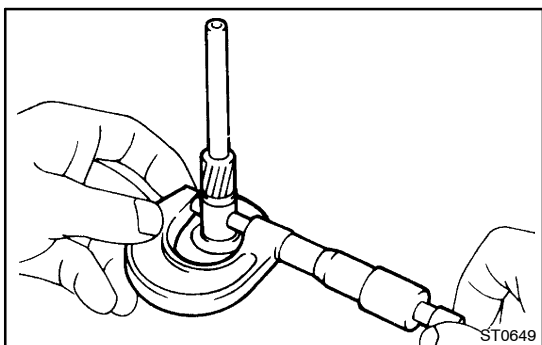

## 9. INSPECT PLANETARY SHAFT AND CENTER BEARING

- (a) Using a micrometer, measure the outer diameter of the surface in contact with the center bearing of the planetary shaft.

**Planetary shaft outer diameter:**

**14.980 – 15.000 mm (0.5898 – 0.5906 in.)**

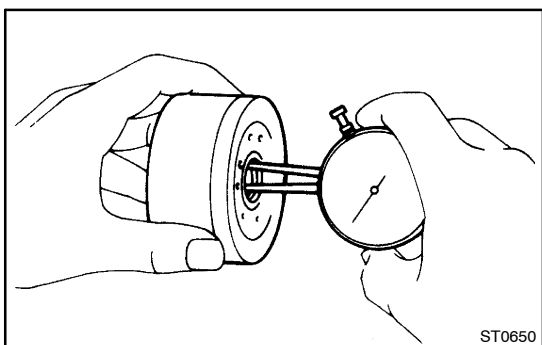

- (b) Using a caliper gauge, measure the inside diameter of the center bearing.

**Center bearing inside diameter:**

**15.008 – 15.050 mm (0.5909 – 0.5925 in.)**

- (c) Subtract the planetary shaft diameter from the bearing inside diameter measurement.

**Standard center bearing oil clearance:**

**0.01 – 0.06 mm (0.0004 – 0.0024 in.)**

**Maximum center bearing oil clearance:**

**0.2 mm (0.008 in.)**

If the clearance is greater than maximum, replace the planetary shaft and center bearing. (See page ST-10)