

## INSPECTION

### 1. INSPECT DISC, PLATE AND FLANGE

Check to see if the sliding surface of the disc, plate and flange are worn or burnt.

If necessary, replace them.

HINT:

- If the lining of the disc is peeling off or discolored, or even if parts of the printed numbers are defaced, replace disc.
- Before assembling new disc, soak it in ATF for at least 15 minutes.

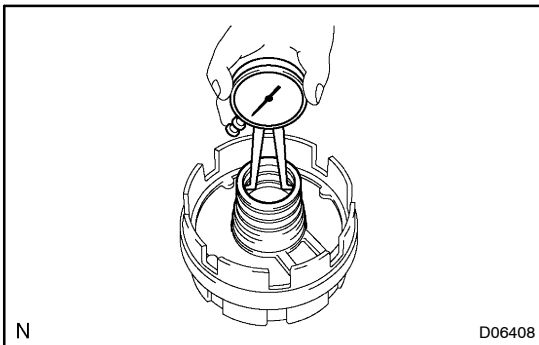

### 2. CHECK CENTER SUPPORT BUSHING

Using a dial indicator, measure the inside diameter of the center support bushing.

**Maximum inside diameter: 36.46 mm (1.4354 in.)**

If the inside diameter is greater than the maximum, replace the center support.