

REMOVAL

1. REMOVE FRONT PART OF FRONT DOOR OPENING TRIMS

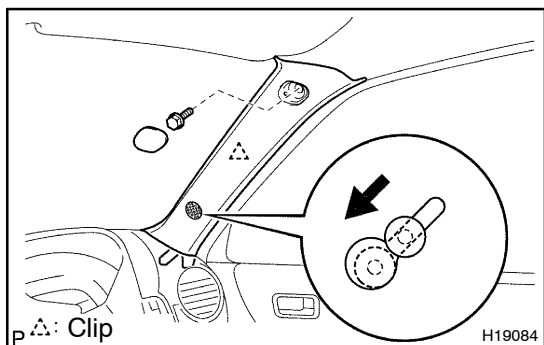

2. REMOVE FRONT PILLAR GARNISHS

- (a) Using a screwdriver, remove the front pillar garnish cover.

HINT:

Tape the screwdriver tip before use.

- (b) Remove the bolt.
 (c) Using a screwdriver, remove the front pillar garnish.

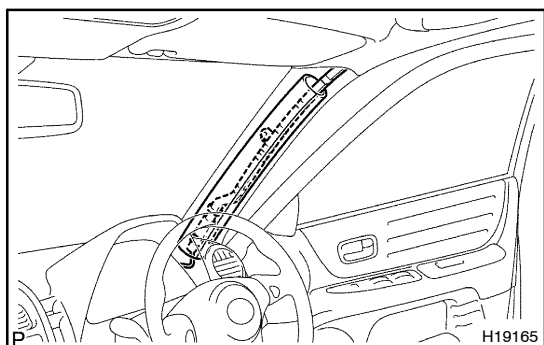

- (d) Remove the bolt.
 (e) Pack the airbag with protection cover.
 (f) Employ the same manner described above to the other side.

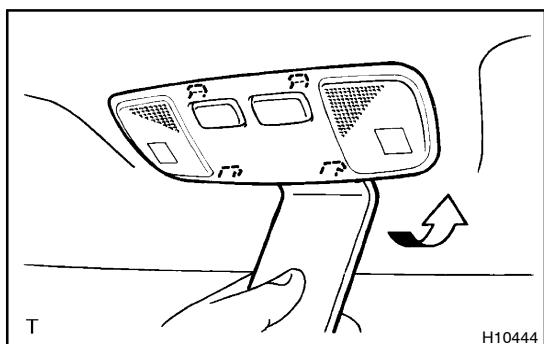

3. w/o Sliding roof:

REMOVE MAP LIGHT ASSEMBLY

- (a) Using a moulding remover, remove the lens.
 (b) Remove the 2 screws and the map light assembly, then disconnect the connectors.

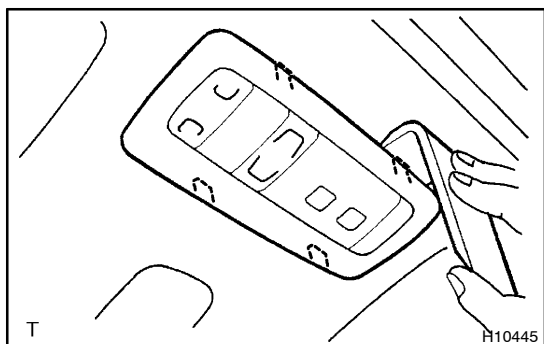

4. w/ Sliding roof:

REMOVE MAP LIGHT ASSEMBLY

- (a) Using a moulding remover, remove the cover.
 (b) Remove the 2 screws and the map light assembly.
 (c) Disconnect the connectors.

5. REMOVE SUN VISORS

- (a) Remove the 2 screws and sun visor, then disconnect the connector.
 (b) Employ the same manner described above to the other side.

6. REMOVE SUN VISOR HOLDERS

Remove the 2 screws and sun visor holder.

7. REMOVE FRONT ASSIST GRIP

(a) Using a screwdriver, remove the caps.

HINT:

Tape the screwdriver tip before use.

(b) Remove the 2 bolts and assist grip.

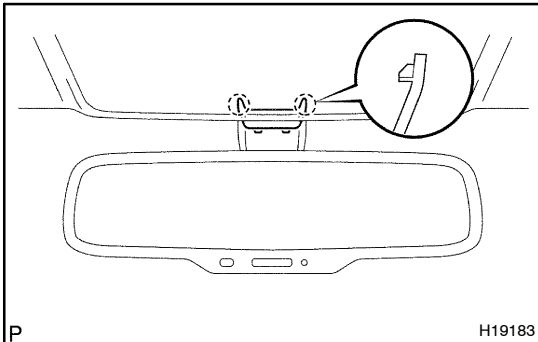
**8. REMOVE INNER REAR VIEW MIRROR**

(a) Using a screwdriver, remove the inner rear view mirror stay holder cover.

HINT:

Tape the screwdriver tip before use.

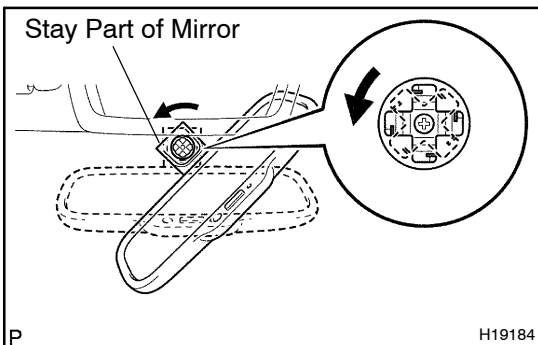

(b) w/ electro chromic inner mirror:

Disconnect the connector.

(c) Remove the mirror assembly by turning the stay part of the mirror counterclockwise.

9. REMOVE WIPER ARMS

(a) Using a screwdriver, remove the 2 wiper arm head covers.

HINT:

Tape the screwdriver tip before use.

(b) Remove the 2 nuts and 2 wiper arms.

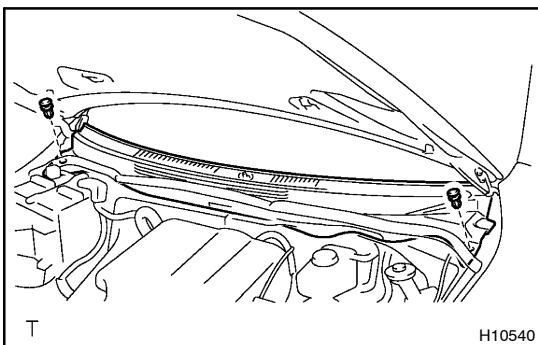
**10. REMOVE COWL TOP VENTILATOR LOUVER**

(a) Remove the hood to cowl top seal.

(b) Remove the 2 clips and cowl top ventilator louver.

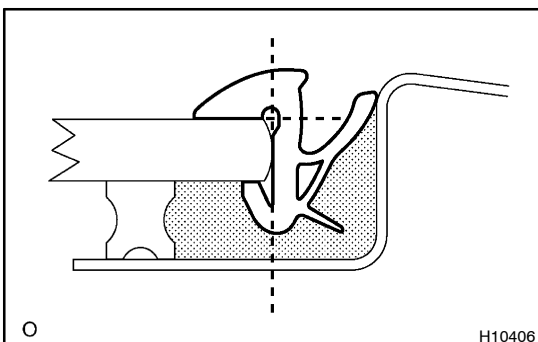
11. PULL DOWN FRONT PART OF ROOF HEADLINING**12. REMOVE WINDSHIELD OUTSIDE MOULDING**

(a) Using a knife, cut off the moulding as shown in the illustration.

NOTICE:

Do not damage the body with the knife.

(b) Remove the remaining moulding.

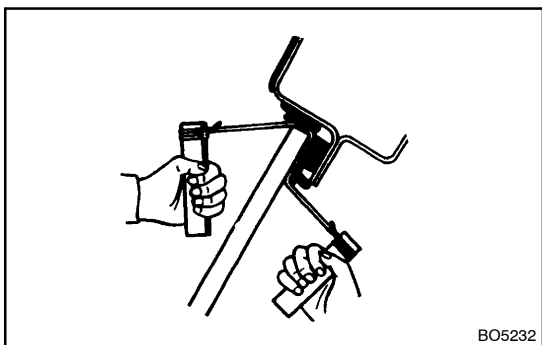
**13. REMOVE WINDSHIELD GLASS**

- (a) Push piano wire through between the body and glass from the interior.
- (b) Tie both wire ends to wooden blocks or similar objects.
- (c) w/ Front window defogger:
Disconnect the connector.

NOTICE:

Be careful not to damage the wire harness.

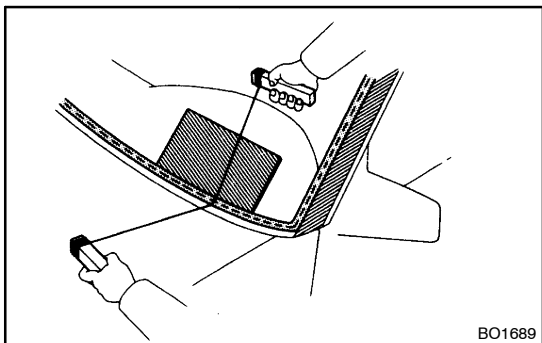

- (d) Cut the adhesive by pulling the piano wire around it.

NOTICE:

When separating the glass, take care not to damage the paint and exterior ornaments. To prevent scratching the safety pad when removing the windshield, place a plastic sheet between the piano wire and safety pad.

HINT:

Apply protective tape to the outer surface to keep the surface from being scratched.

- (e) Remove the glass.

NOTICE:

Leave as much of the adhesive on the body as possible when cutting off the glass.