

REMOVAL

1. REMOVE BACK DOOR TRIM BOARD UPPER

Using a screwdriver, remove the back door trim board upper.

HINT:

Tape the screwdriver tip before use.

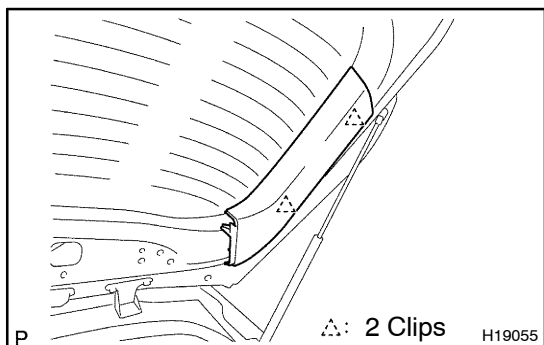

2. REMOVE BACK DOOR TRIM COVERS

(a) Insert a screwdriver between the back door panel and back door trim cover to pry the cover.

HINT:

Tape the screwdriver tip before use.

(b) Employ the same manner described above to the other side.

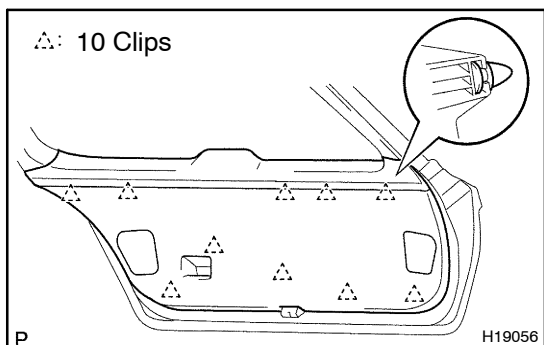

3. REMOVE BACK DOOR TRIM BOARD

(a) Remove the clip and back door handle.

(b) Using a screwdriver, remove the back door trim board.

HINT:

Tape the screwdriver tip before use.

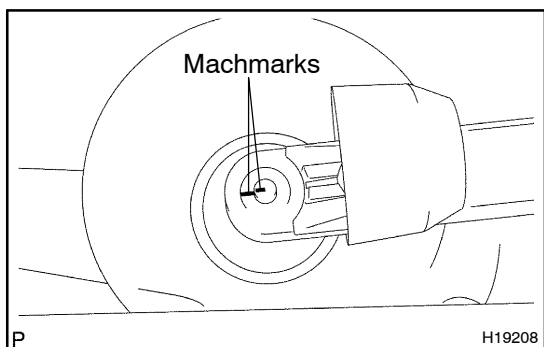

4. REMOVE REAR WIPER ARM

(a) Remove the wiper arm cover.

(b) Place machmarks on the wiper arm and wiper motor.

(c) Remove the nut and rear wiper arm.

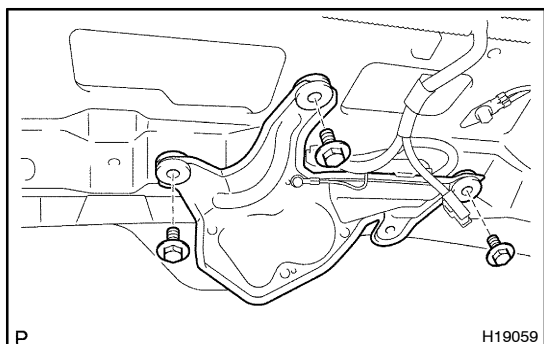

5. REMOVE REAR WIPER MOTOR

(a) Remove the nut and washer on the outer side of back door panel.

(b) Disconnect the connector.

(c) Remove the 3 bolts and rear wiper motor.

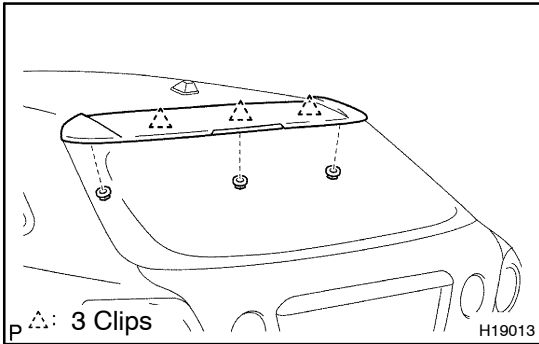
**6. REMOVE REAR SPOILER COVER**

- (a) Remove the 3 nuts.
- (b) Using a screwdriver, remove the rear spoiler cover then disconnect the connector.

HINT:

Tape the screwdriver tip before use.

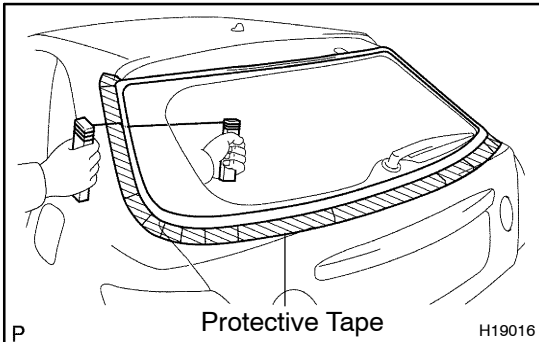
**7. REMOVE BACK DOOR GLASS**

- (a) Disconnect the connector.
- (b) Push piano wire through from the interior.
- (c) Tie both wire ends to wooden blocks or similar object.

HINT:

Apply protective tape to the outer surface to keep the surface from being scratched.

NOTICE:

When separating the glass, take care not to damage the paint and exterior.

- (d) Cut the adhesive by pulling the piano wire around it.

HINT:

Cut the adhesive areas as shown in the illustration, leaving the adhesive where the clips are.

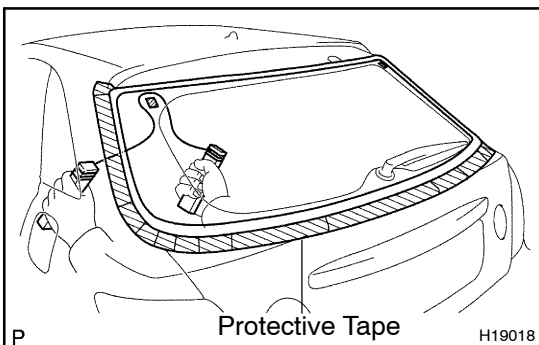
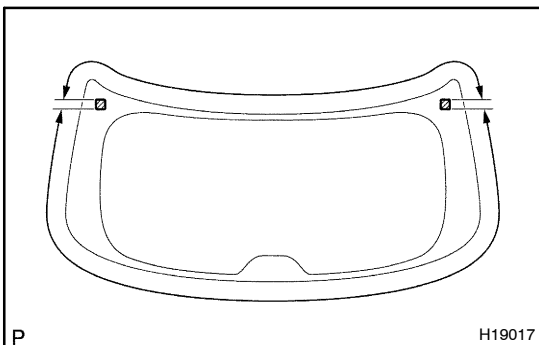

- (e) Let the piano wire pass as shown in the illustration, cut off the adhered part to the clips.

NOTICE:

Do not damage the glass retainers.

- (f) Remove the glass.

NOTICE:

Leave as much of the adhesive on the body as possible when cutting off the glass.