

PRE-CHECK

1. DIAGNOSIS SYSTEM

(a) Description for EURO-OBD (European spec.)

- When troubleshooting Euro-OBd vehicles, the only difference from the usual troubleshooting procedure is that you connect to the vehicle the OBD scan tool complying with ISO 15031-4 or hand-held tester, and read off various data output from the vehicle's engine ECU.

Euro-OBd regulations require that the vehicle's on-board computer lights up the check engine warning ignition the instrument panel when the computer detects a malfunction in the emission control system/components or in the powertrain control components which affect vehicle emissions, or a malfunction in the computer. In addition to the check engine warning light (CHK ENG) lighting up when a malfunction is detected, the applicable Diagnostic Trouble Codes (DTCs) prescribed by ISO15031-6 are recorded in the engine ECU memory (See page DI-17). If the malfunction does not repaired in 3 consecutive trips, the (CHK ENG) goes off automatically but the DTCs remain recorded in the engine ECU memory.

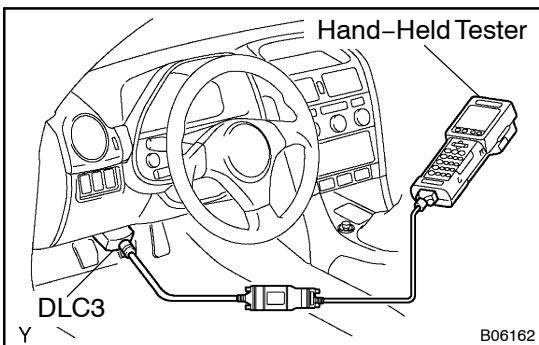

- To check the DTCs, connect the OBD scan tool or hand-held tester to the Data Link Connector 3 (DLC3) on the vehicle. The OBD scan tool or hand-held tester also enables you to erase the DTCs and check frozen frame data and various forms of engine data (For operating instructions, see the OBD scan tool's instruction book.). DTCs include ISO controlled codes and manufacturer controlled codes. ISO controlled codes must be set as prescribed by the ISO, while manufacturer controlled codes can be set freely by the manufacturer within the prescribed limits (See DTC chart on page DI-17).
- The diagnosis system operates in normal mode during normal vehicle use. It also has a check mode for technicians to simulate malfunction symptoms and troubleshoot. Most DTCs use 2 trip detection logic* to prevent erroneous detection, and ensure thorough malfunction detection. By switching the engine ECU to check mode when troubleshooting,

the technician can cause the check engine warning light to light up for a malfunction that is only detected once or momentarily (Hand-held tester only) (See step 2).

- *2 trip detection logic:
When a malfunction is first detected, the malfunction is temporarily stored in the engine ECU memory. (1st trip) If the same malfunction is detected again during the second drive test, this second detection causes the (CHK ENG) to light up. (2nd trip) (However, the ignition switch must be turned OFF between the 1st trip and the 2nd trip.).
- Freeze frame data:
Freeze frame data records the engine condition when a misfire (DTCs P0300 - P0306) or fuel trim malfunction (DTCs P0171, P0172, P0174 and P0175) or other malfunction (first malfunction only), is detected.
Because freeze frame data records the engine conditions (fuel system, calculated load, engine coolant temperature, fuel trim, engine speed, vehicle speed, etc.) when the malfunction is detected, when troubleshooting, it is useful to determine whether the vehicle was running or stopped, the engine was warmed up or not, the air-fuel ratio was lean or rich, etc. at the time of the malfunction.

Priorities for troubleshooting:

If troubleshooting priorities for multiple DTCs are given in the applicable DTC chart, these should be followed.

If no instructions are given, troubleshoot DTCs according to the following priorities.

- (1) DTCs other than fuel trim malfunction (DTCs P0171, P0172, P0174 and P0175) and misfire (DTCs P0300 - P0306).
- (2) Fuel trim malfunction (DTCs P0171, P0172, P0174 and P0175).
- (3) Misfire (DTCs P0300 - P0306).

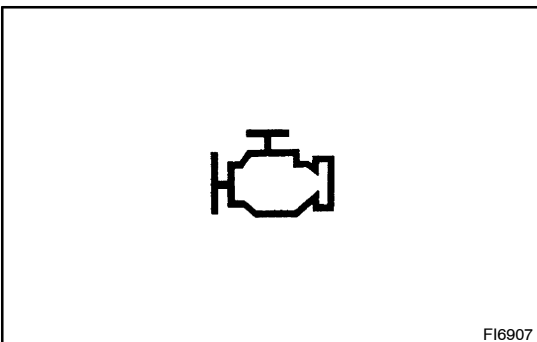

(b) Description for M-OBD (Except European spec.)

- When troubleshooting Multiplex OBD (M-OBD) vehicles, the only difference from the usual troubleshooting procedure is that you connect the vehicle to the hand-held tester, and read off various data output from the vehicle's engine ECU.
- The vehicle's on-board computer indicates the check engine light (CHK ENG) on the instrument panel when the computer detects a malfunction in the computer itself or in drive system components.

In addition to an indication of the CHK ENG when a malfunction is detected, the applicable Diagnostic Trouble Codes (DTCs) recorded in the engine ECU memory (See page DI-17). When the malfunction does not reoccur, the CHK ENG is indicated until the ignition switch is turned off, and then the CHK ENG is not indicated when the ignition switch is turned on but the DTCs remain recorded in the engine ECU memory.

- To check the DTCs, connect the hand-held tester to Data Link Connector 3 (DLC3) on the vehicle or read the DTC which is indicated on the multi information display when TC and CG terminals on the DLC3 are connected. The hand-held tester also enables you to erase the DTCs and check freeze frame data and various forms of engine data. (For operating instructions, see the instruction book.)
- The diagnosis system operates in normal mode during normal vehicle use. It also has a check (test) mode for technicians to simulate malfunction symptoms and troubleshoot. Most DTCs use 2 trip detection logic* to prevent erroneous detection, and ensure thorough malfunction detection. By switching the engine ECU to check (test) mode using hand-held tester when troubleshooting, the technician can cause the CHK ENG on the light up for a malfunction that is only detected once or momentarily (Hand-held tester only) (See step 2).
- * 2 trip detection logic:
When a logic malfunction is first detected, the malfunction is temporarily stored in the engine ECU memory. If the same malfunction is detected again during the second drive test, this second detection causes the CHK ENG to light up.
The 2 trip repeats the same mode for 2 times. (However, the ignition switch must be turned OFF between the 1st trip and 2nd trip)
- Freeze frame data:
Freeze frame data records the engine condition when malfunction is detected.
Because freeze frame data records the engine conditions (fuel system, calculator load, water temperature, fuel trim, engine speed, vehicle speed, etc.) when the malfunction is detected, when troubleshooting, it is useful for determining whether the vehicle was running or stopped, the engine was warmed up or not, the air-fuel ratio was lean or rich, etc. at the time of the malfunction.

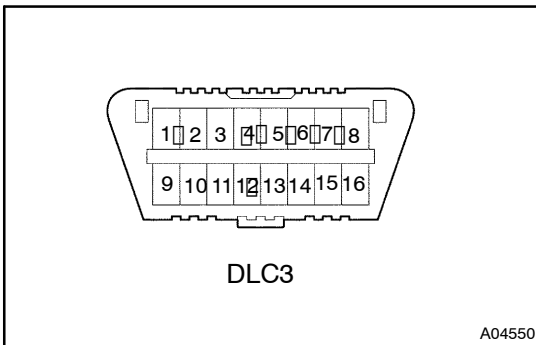

(c) Check the DLC3.

The vehicle's engine ECU uses the ISO 9141-2 (Euro-OBD)/ISO 14230 (M-OBD) communication protocol. The terminal arrangement of DLC3 complies with ISO 15031-3 and matches the ISO 9141-2/ISO 14230 format.

Terminal No.	Connection/Voltage or Resistance	Condition
7	Bus \oplus Line/Pulse generation	During transmission
4	Chassis Ground \leftrightarrow Body Ground/1 Ω or less	Always
16	Battery Positive \leftrightarrow Body Ground/9 - 14 V	Always

HINT:

- If communication is normal when the tool is connected to another vehicle, inspect DLC3 on the original vehicle.
- If communication is still not possible when the tool is connected to another vehicle, the problem is probably in the tool itself, so consult the Service Department listed in the tool's instruction manual.

2. INSPECT DIAGNOSIS (Normal Mode)

(a) Check the DTC using hand-held tester.

NOTICE:

Hand-held tester only:

When the diagnosis system is switched from normal mode to check mode, it erases all DTCs and freezes frame data recorded in normal mode. So before switching modes, always check the DTCs and frozen frame data, and note them down.

- (1) Prepare the hand-held tester.
- (2) Connect the hand-held tester to DLC3.
- (3) Turn the ignition switch ON and push the hand-held tester main switch ON.
- (4) Use the hand-held tester to check the DTCs and frozen frame data, note them down. (For operating instructions, see the hand-held tester instruction book.)
- (5) See page DI-17 to confirm the details of the DTCs.

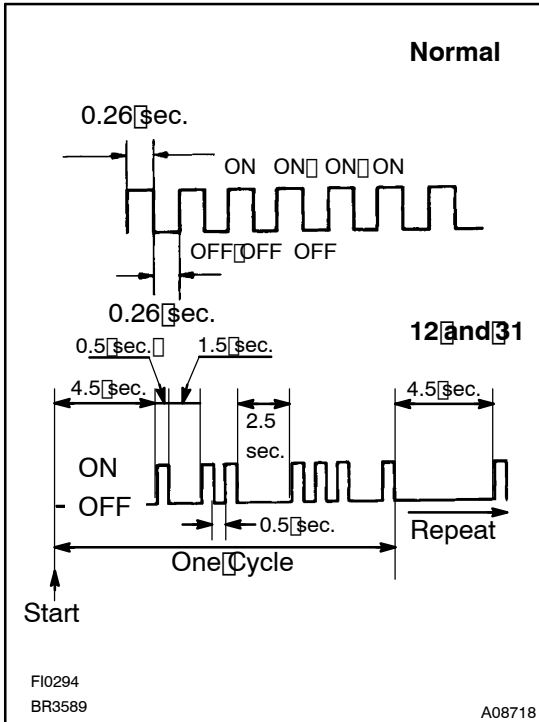
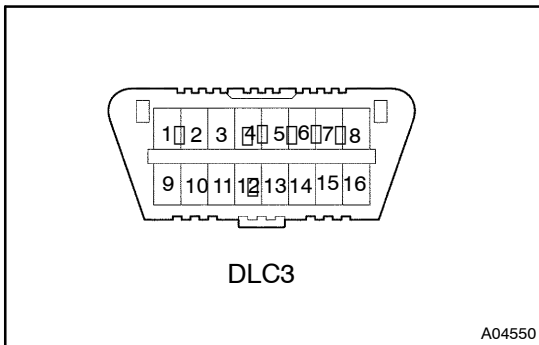

(b) Except European Spec.:

Check the DTC when not using hand-held tester.

(1) Turn the ignition switch ON.

(2) Using SST, connect between terminals 13 (TC) and 4 (CG) of the DLC3.

SST 09843-18040

(3) Read the DTC from the check engine warning light (CHK ENG).

As an example, the blinking patterns for codes, normal, 12 and 31 are as shown in the illustration.

(4) Check the details of the malfunction using the DTC chart on [page DI-17](#).

(5) After completing the check, disconnect terminals 13 (TC) and 4 (CG) and turn off the display.

HINT:

In the event of 2 or more malfunction cords, the indication will begin from the smaller numbered cord and continue in order to the larger.

(6) Push the function key of the steering switch until EFI will be displayed on the instrument panel.

(7) Read the DTC on the instrument panel.

HINT:

- If a DTC is not indicated, check the TC terminal circuit.
- If a code No.89 is indicated, read the number of blinks of the ECT SNOW indication to get the DTC for the electric throttle control system (ETCS).

NOTICE:

- **When simulating symptoms with out a hand-held tester to check the DTCs, use normal mode. For code on the DTC chart subject to "2 trip detection logic", turn the ignition switch OFF after the symptom is simulated the first time. Then repeat the simulation process again. When the problem has been simulated twice, the CHECK ENG is indicated on the instrument panel and the DTCs are recorded in the engine ECU.**
- **Check the 1st trip DTC using Mode 7 for ISO 15031 (Continuous Test Results of Euro-OBD function in hand-held tester).**

(c) Check the DTC for ETCS

(1) Turn the ignition switch ON.

HINT:

If the ECT SNOW indicator does not light up, troubleshoot the combination meter ([See page BE-31](#)).

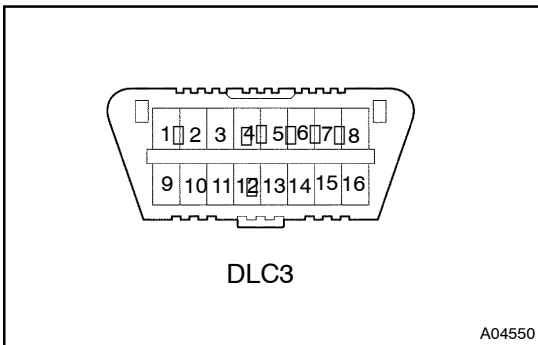

- (2) Using SST, connect between terminals 13 (TC) and 4 (CG) of the DLC3.

SST 09843-18040



- (3) Read the DTC from the ECT snow indicator the combination meter.

HINT:

If a DTC is not output, check the TC terminal circuit.

- (4) Check details of the malfunction using the DTC chart on [page DI-17](#).
- (5) After completing the check, disconnect terminals 13 (TC) and 4 (CG) and turn off the display.

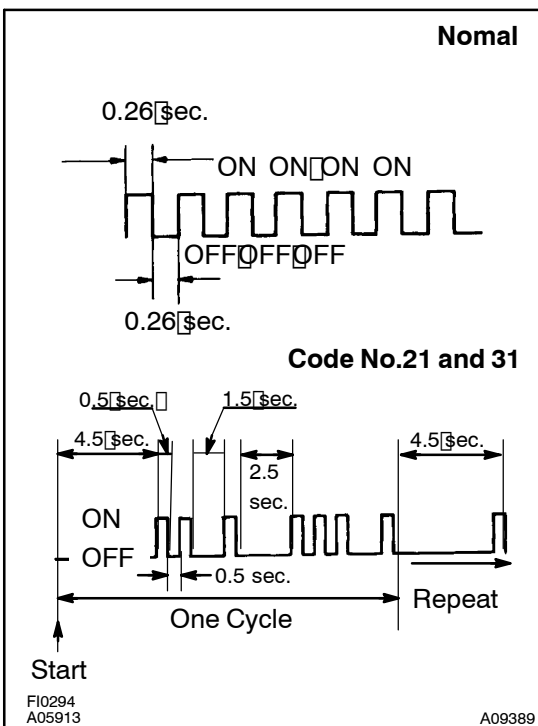

HINT:

In the event of 2 or more malfunction codes, indication will begin from the smaller numbered code and continue in order to the larger.

- (d) Clear the DTC.

The DTCs and freeze frame data will be erased by either actions.

- (1) Operating the hand-held tester to erase the codes (See the hand-held tester's instruction book for operating instructions.).
- (2) Disconnecting the battery terminals of EFI and ECTS fuses.

NOTICE:

If the hand-held tester switches the engine ECU from normal mode to check mode or vice-versa, or if the ignition switch is turned from ON to ACC or OFF during check mode, the DTCs and freeze frame data will be erased.

3. INSPECT DIAGNOSIS (Check (Test) Mode)

HINT:

Hand-held tester only:

Compared to the normal mode, the check mode has an increased sensitivity to detect malfunctions.

Furthermore, the same diagnostic items which are detected in the normal mode can also be detected in the check (test) mode.

- (a) Check the DTC.

- (1) Initial conditions

- Battery voltage 11 V or more
- Throttle valve fully closed.
- Transmission in P or N position
- A/C switched OFF

- (2) Turn the ignition switch OFF.
- (3) Prepare the hand-held tester.
- (4) Connect the hand-held tester to the DLC3.
- (5) Turn the ignition switch ON and push the hand-held tester main switch ON.
- (6) Switch the hand-held tester from the normal mode to the check (test) mode.

NOTICE:

If the hand-held tester switches the engine ECU from normal mode to check mode or vice-versa, or if the ignition switch is turned from ON to ACC or OFF during check mode, the DTCs and frozen frame data will be erased.

- (7) Start the engine.
- (8) Simulate the conditions of the malfunction described by the customer.

NOTICE:

Leave the ignition switch ON until you have checked the DTCs, etc.

- (9) After simulating the malfunction conditions, use the hand-held tester diagnosis selector to check the DTCs and frozen frame data, etc.

HINT:

Take care not to turn the ignition switch OFF. Turning the ignition switch OFF switches the diagnosis system from check (test) mode to normal mode. so all DTCs, etc. are erased.

- (10) After checking the DTC, inspect the applicable circuit.

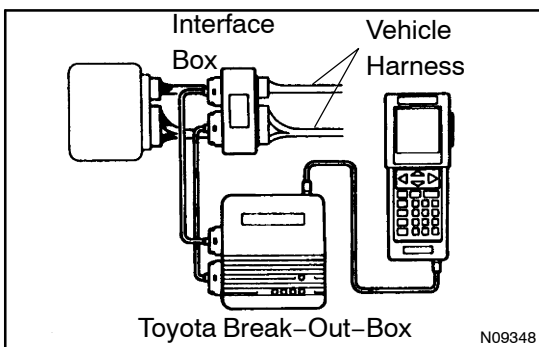

(b) Engine ECU Terminal Values Measurement Using Break-Out-Box and Hand-Held Tester

- (1) Hook up the break-out-box and hand-held tester to the vehicle.
- (2) Read the engine ECU input/output values by following the prompts on the tester screen.

HINT:

- Hand-held tester has a "Snapshot" function. This records the measured values and is effective in the diagnosis of intermittent problems.
- Please refer to the hand-held tester/break-out-box operator's manual for further details.

4. FAIL-SAFE CHART

If any of the following codes is recorded, the engine ECU enters fail-safe mode.

DTC No.	Fail-Safe Operation	Fail-Safe Deactivation Conditions
P0100/31	From the amount of throttle valve opening and the engine rpm, estimate the amount of inhaled air.	Returned to normal condition
P0110/24	Intake air temperature is fixed at 20°C (68°F)	Returned to normal condition
P0115/22	Water temperature is fixed at 80°C (176°F)	Returned to normal condition

P0120/41	Saved driving mode	Ignition switch OFF
P0135/21 P0141/21 P0155/28 P0161/28	The heater circuit in which an abnormality is detected is turned off	Ignition switch OFF
P0325/52 P0330/53	Max. timing retardation	Ignition switch OFF
P1300/14 P1305/15 P1310/14 P1315/14 P1320/14 P1325/14 P1330/14 P1340/14	Fuel cut	Returned to normal condition

5. CHECK FOR INTERMITTENT PROBLEMS

HINT:

Hand-held tester only:

By putting the vehicle's engine ECU in the check (test) mode, 1 trip detection logic is possible instead of 2 trip detection logic and sensitivity to detect open circuits is increased. This makes it easier to detect intermittent problems.

- (a) Clear the DTCs (See step 2).
- (b) Set the check (Test) mode (See step 3).
- (c) Perform a simulation test (See page N-23).
- (d) Check the connector and terminal (See page N-34).
- (e) Handle the connector (See page N-34).

6. BASIC INSPECTION

When the malfunction code is not confirmed in the DTC check, troubleshooting should be performed in the order for all possible circuits to be considered as the causes of the problems. In many cases, by carrying out the basic engine check shown in the following flow chart, the location causing the problem can be found quickly and efficiently. Therefore, use of this check is essential in engine troubleshooting.

1	Is battery voltage 11 V or more when engine is stopped?
----------	--

NO

Charge or replace battery.

YES

2	Is engine cranked?
----------	---------------------------

NO

Proceed to problems table (See page DI-24)

YES

3 Does engine start?

NO

Go to step 7.

YES

4 Check air filter.

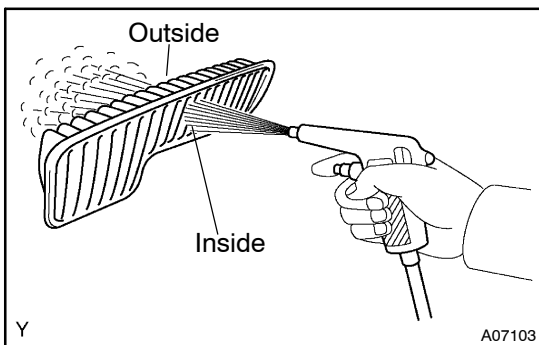

PREPARATION:

Remove the air filter.

CHECK:

Visually check that the air filter is not dirty or excessive oily.

HINT:

If necessary, clean the air filter with compressed air. First blow from inside thoroughly, then blow from outside of the air filter.

NG

Repair or replace

OK

5 Check idle speed.

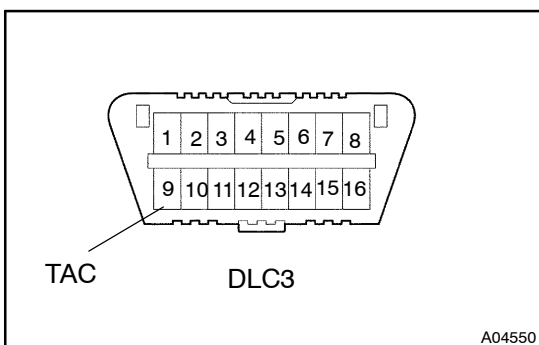

PREPARATION:

- Warm up the engine to normal operating temperature.
- Switch off all the accessories.
- Switch off the A/C.
- Shift the transmission into the N position.
- Connect the hand-held tester to the DLC3 on the vehicle.
- If you have no hand-held tester, connect tachometer test probe to terminal 9 (TAC) of the DLC3.
SST 09843-18030

NOTICE:

As some tachometers are not compatible with this ignition system, we recommend that you confirm the compatibility of your unit before use.

CHECK:

Check the idle speed.

OK:

Idle speed: 650 - 750 rpm

NG

Proceed to problem symptoms table (See [page DI-24](#)).

OK

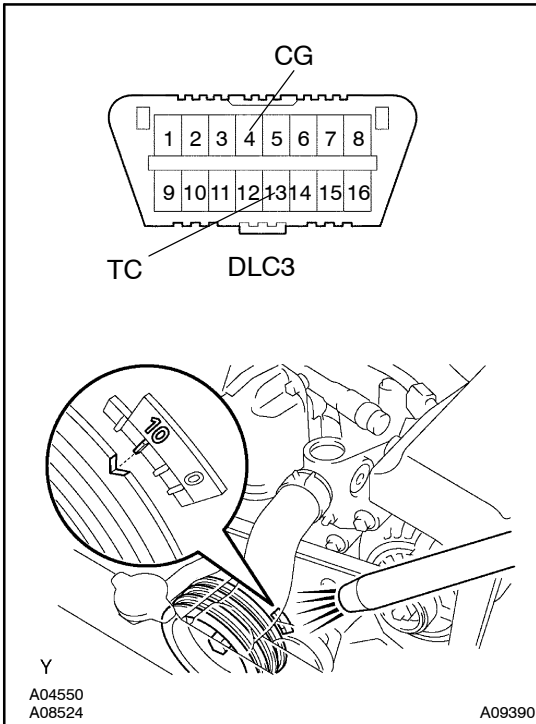
6 Check ignition timing.**PREPARATION:**

- Warm up the engine to normal operating temperature.
- Shift the transmission into the N position.
- Keep the engine speed at idle.
- Using SST, connect terminals 13 (TC) and 4 (CG) of the DLC3.
SST 09843-18040
- Using a timing light, connect the tester to the ignition coil connector [wire] [See page EM-12].

CHECK:

Check the ignition timing.

OK:**Ignition timing: 10° BTDC at idle**

NG

Proceed to [page G-1](#) and continue to [trouble-shoot](#).

OK

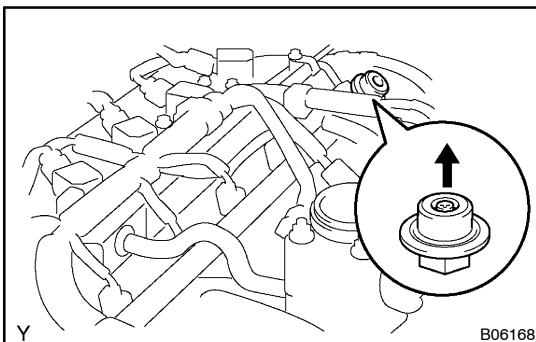
Proceed to [problem symptoms table](#) (See [page DI-24](#)).**7 Check fuel pressure.****PREPARATION:**

- Be sure that enough fuel is in the tank.
- Connect the hand-held tester to the DLC3.
- Turn the ignition switch ON and push hand-held tester main switch ON.
- Use the **ACTIVE TEST** mode to operate the fuel pump.
- Please refer to the hand-held tester operator's manual for further details.
- If you have no hand-held tester, connect the positive (+) and negative (-) leads from the battery to the fuel pump connector [See page FI-6].

CHECK:

Check that pulsation damper screw rises up when fuel pump operates.

HINT:

At this time, you will hear a fuel flowing noise.

NG

Proceed to [page FI-6](#) and continue to troubleshoot.

OK

8 Check for spark.**PREPARATION:**

- Remove the ignition coil from the spark plug.
- Remove the spark plug.
- Install the spark plug to the ignition coil.
- Disconnect the injector connector.
- Ground the spark plug.

CHECK:

Check if spark occurs while engine is being cranked.

NOTICE:

To prevent excess fuel being from injected from the injectors during this test, don't crank the engine for more than 5 – 10 seconds at a time.

NG

Proceed to [page G-1](#) and continue to troubleshoot.

OK

Proceed to [problem symptoms table](#) (See [page DI-24](#)).

7. ENGINE OPERATING CONDITION**NOTICE:**

The values given below for "Normal Condition" are representative values, so a vehicle may still be normal even if its value varies differ from those listed here. So do not decide whether a part is faulty or not solely according to the "Normal Condition" here.

Hand-held tester display	Measurement Item	Normal Condition*
FUEL SYS #1	Fuel System Bank 1 OPEN: Air-fuel ratio feedback stopped CLOSED: Air-fuel ratio feedback operating	Idling after warming up: CLOSED
FUEL SYS #2	Fuel System Bank 2 OPEN: Air-fuel ratio feedback stopped CLOSED: Air-fuel ratio feedback operating	Idling after warming up: CLOSED

DIAGNOSTICS - ENGINE (2JZ-GE)

CALC LOAD	Calculator Load: Current intake air volume as a proportion of max. intake air volume	Idling: 19.7 – 50.4 % Racing without load (2,500rpm): 16.8 – 47.4 %
COOLANT TEMP	Water Temp. Sensor Value	After warming up: 80 – 95 °C (176 – 203 °F)
SHORT FT #1	Short-term Fuel Trim Bank 1	0 ± 20 %
LONG FT #1	Long-term Fuel Trim Bank 1	0 ± 20 %
SHORT FT #2	Short-term Fuel Trim Bank 2	0 ± 20 %
LONG FT #2	Long-term Fuel Trim Bank 2	0 ± 20 %
ENGINE SPD	Engine Speed	Idling: 650 – 750 rpm
VEHICLE SPD	Vehicle Speed	Vehicle stopped: 0 km/h (0 mph)
IGN ADVANCE	Ignition Advance: Ignition Timing of Cylinder No.1	Idling: BTDC 5 – 15 °
INTAKE AIR	Intake Air Temp. Sensor Value	Equivalent to ambient temp.
MAF	Air Flow Rate Through Mass Air Flow Meter	Idling: 3.2 gm/ sec. Racing without load (2,500 rpm): 11.2 gm/sec.
THROTTLE POS	Voltage Output of Throttle Position Sensor Calculated as a percentage: 0 V → 0 %, 5 V → 100 %	Throttle fully closed: 8 – 20 % Throttle fully open: 64 – 96 %
O2S B1 S1	Voltage Output of Oxygen Sensor Bank 1 Sensor 1	Idling: 0.1 – 0.9 V
O2S B1 S2	Voltage Output of Oxygen Sensor Bank 1 Sensor 2	Driving (50 km/h, 31 mph): 0.1 – 0.9 V
O2S B2 S1	Voltage Output of Oxygen Sensor Bank 2 Sensor 1	Idling: 0.1 – 0.9 V
O2S B2 S2	Voltage Output of Oxygen Sensor Bank 2 Sensor 2	Driving: (50 km/h, 31 mph): 0.1 – 1.0 V
O2FT B1 S1	Oxygen Sensor Fuel Trim Bank 1, Sensor 1 (Same as SHORT FT #1)	0 ± 20 %
O2FT B2 S1	Oxygen Sensor Fuel Trim Bank 2, Sensor 1 (Same as SHORT FT #2)	0 ± 20 %
MIL ON RUN DIST	Distance since activation of check engine warning light	When there is no DTC: 0 km/h (0 mph)
INJECTOR	Fuel injection time for cylinder No.1	Idling: 1.9 ms
MISFIRE RPM	Engine RPM for first misfire range	Misfire 0: 0 rpm
MISFIRE LOAD	Engine load for first misfire range	Misfire 0: 0 g/r
STARTER SIG	Starter Signal	Cranking: ON
A/C SW	A/C Switch Signal	A/C ON: ON
PNP SW	Park/Neutral Position Switch Signal	P or N position: ON
ELE LOAD SIG	Electrical Load Signal	Defogger switch ON: ON
SW	Closed Throttle Position	Throttle fully closed: ON
STOP LIGHT SW	Stop Light Switch Signal	Stop light switch ON: ON
PS OIL PRESS SW	Power Steering Oil Pressure Switch Signal	Turn steering wheel: ON
FC IDL	Fuel Cut Idle: Fuel cut when throttle valve fully closed, during deceleration	Fuel cut operating: ON
FC TAU	Fuel Cut TAU: Fuel cut during very light load	Fuel cut operating: ON
CYL#1 – CYL#6	Abnormal revolution variation for each cylinder	0 %
IGNITION	Total number of ignition for every 1,000 revolutions	0 – 300
INTAKE CTRL VSV1	Intake Air Control Valve VSV Signal	VSV operating: ON

FUEL PUMP	Fuel Pump Signal	Idling: ON
EVAP VSV	EVAP VSV Signal	VSV operating: ON
THROTTLE POS #2	Throttle position sensor No.2 output voltage	Throttle fully closed: 2.0 – 2.9 V Throttle fully open: 4.6 – 5.0 V
ACCEL POS #1	Accelerator pedal position sensor No.1 output voltage	Accelerator pedal released: 0.25 – 0.9 V Accelerator pedal depressed: 3.2 – 4.8 V
ACCEL POS #2	Accelerator pedal position sensor No.2 output voltage	Accelerator pedal released: 1.8 – 2.7 V Accelerator pedal depressed: 4.7 – 5.0 V
THROTTLE TARGET	Target position of throttle valve	Idling: 0.4 – 1.1 V
THROTL OPN DUTY	Throttle motor opening duty ratio	Throttle fully closed: 0 % When accelerator pedal is depressed, duty ratio is increased
THROTL CLS DUTY	Throttle motor closed duty ratio	Throttle fully closed: 0 % When accelerator pedal is quick released, duty ratio is increased
THROTTLE MOT	Whether or not throttle motor control is permitted	Idling: ON
CLUTCH	Whether or not magnetic clutch control is permitted	Idling: ON
+BM	Whether or not electric throttle control system power is inputted	Idling: ON
ACCEL IDL POS	Whether or not accelerator pedal position sensor is detecting idle	Idling: ON
THROTTLE IDL POS	Whether or not throttle position sensor is detecting idle	Idling: ON
FAIL #1	Whether or not fail safe function is executed	ETCS is failed: ON
FAIL #2	Whether or not fail safe function is executed	ETCS is failed: ON
THROTTL INITAL	Throttle fully closed learning value	0.4 – 0.8 V
ACCEL LEARN VAL	Accelerator fully closed learning value	0.4 – 0.8 V
THROTTLE MOT	Throttle motor control current	Idling: 0 – 3.0 A
CLUTCH	Magnetic clutch control current	0.8 – 1.0 A
A/C MAG CLUTCH	A/C switch signal	A/C ON: ON
VVT CTRL	VVT control signal	VVT operation: ON
TOTAL FT B1	Total Fuel Trim Bank 1: Average value for fuel trim system of bank 1	Idling: 0.5 – 1.4
TOTAL FT B2	Total Fuel Trim Bank 2: Average value for fuel trim system of bank 2	Idling: 0.5 – 1.4
O2 LR B1 S1	Oxygen Sensor Lean Rich Bank 1 Sensor 1: Response time for oxygen sensor output to switch from lean to rich	Idling after warming up: 0 – 1,000 msec.
O2 LR B2 S1	Oxygen Sensor Lean Rich Bank 2 Sensor 1: Response time for oxygen sensor output to switch from lean to rich	Idling after warming up: 0 – 1,000 msec.
O2 RL B1 S1	Oxygen Sensor Rich Lean Bank 1 Sensor 1: Response time for oxygen sensor output to switch from rich to lean	Idling after warming up: 0 – 1,000 msec.
O2 RL B2 S1	Oxygen Sensor Rich Lean Bank 2 Sensor 1: Response time for oxygen sensor output to switch from rich to lean	Idling after warming up: 0 – 1,000 msec.

*: If no conditions are specifically stated for "Idling", it means the shift lever is at N or P position, the A/C switch is OFF and all accessory switches are OFF.