

CIRCUIT INSPECTION

DTC	P0100/31	Air Flow Meter Circuit Malfunction
------------	-----------------	---

CIRCUIT DESCRIPTION

The air flow meter uses a platinum hot wire. The hot wire air flow meter consists of a platinum hot wire, temperature sensor and a control circuit installed in a plastic housing. The hot wire air flow meter works on the principle that the hot wire and temperature sensor located in the intake air bypass of the housing detect any changes in the intake air temperature.

The hot wire is maintained at the set temperature by controlling the current flow through the hot wire. This current flow is then measured as the output voltage of the air flow meter.

The circuit is constructed so that the platinum hot wire and temperature sensor provide a bridge circuit with the power transistor controlled so that the potential of A and B remains equal to maintain the set temperature.

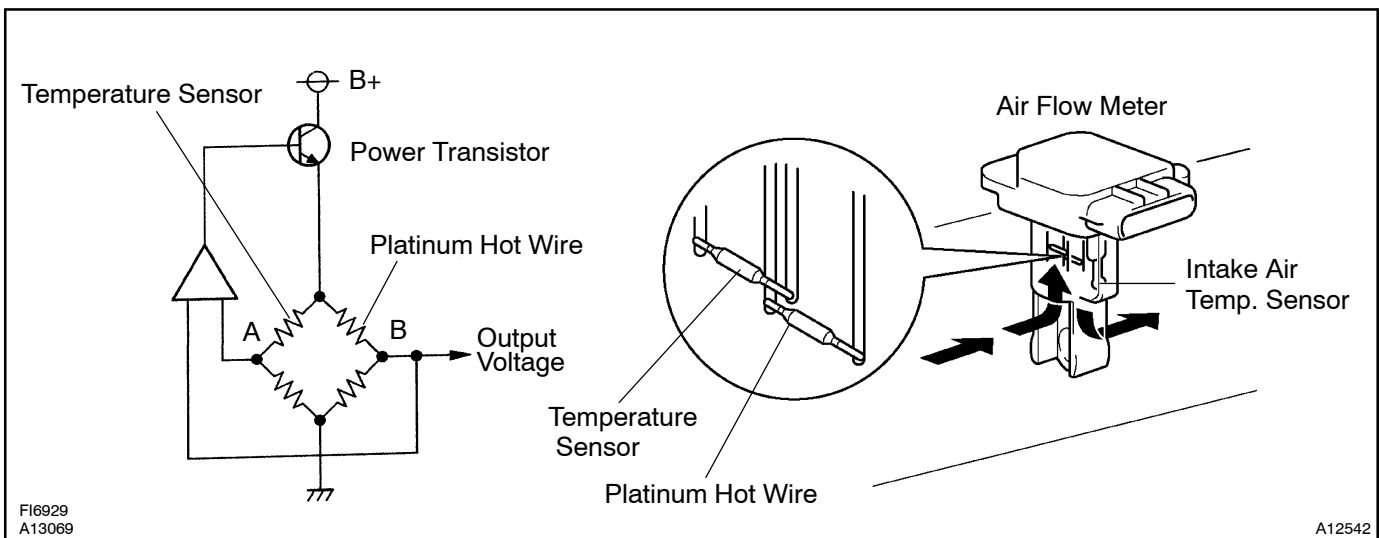

DTC No.	DTC Detection Condition	Trouble Area
P0100/31	Open or short in air flow meter circuit with more than 3 sec. and engine speed is less than 4,000 rpm	<ul style="list-style-type: none"> • Open or short in air flow meter circuit • Air flow meter • Engine ECU

HINT:

After confirming DTC P0100/31, use the hand-held tester to confirm the air flow ratio from the CURRENT DATA.

Air Flow Value (gm/sec.)	Malfunction
Approx. 0.0	<ul style="list-style-type: none"> • Air flow meter power source circuit open • VG circuit open or short
271.0 or more	<ul style="list-style-type: none"> • EVG circuit open

WIRING DIAGRAM

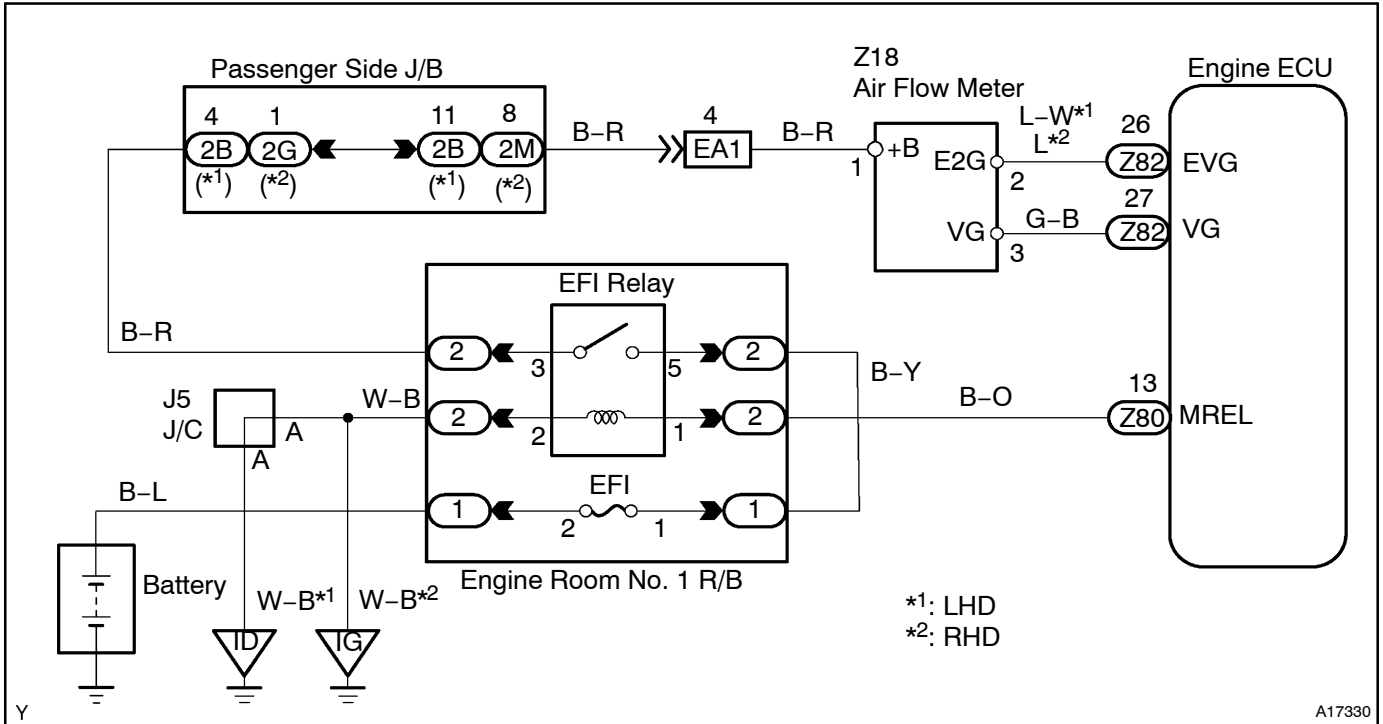

INSPECTION PROCEDURE

HINT:

Read freeze frame data using hand-held tester. Because freeze frame records the engine conditions when the malfunction is detected. When troubleshooting, it is useful for determining whether the vehicle was running or stopped, the engine was warmed up or not, the air-fuel ratio was lean or rich, etc. at the time of the malfunction.

1	Connect hand-held tester, and read value of air flow rate.
----------	---

PREPARATION:

- (a) Connect the hand-held tester to the DLC3.
- (b) Turn the ignition switch ON and push the hand-held tester main switch ON.
- (c) Start the engine.

CHECK:

Read the air flow rate on the hand-held tester.

RESULT:

	Type I	Type II
Air Flow Rate (gm/sec.)	0.0	271.0 or more

Type I	Go to step 2.
Type II	Go to step 5.

2 Check voltage of air flow meter power source.

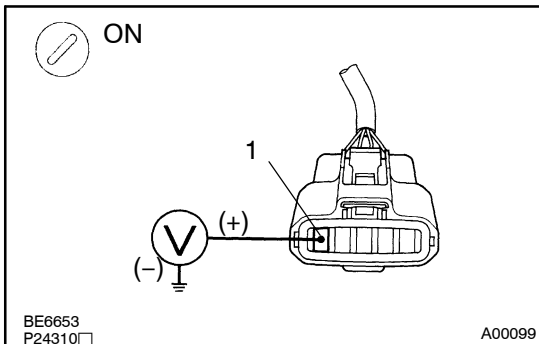

PREPARATION:

- Disconnect the air flow meter connector.
- Turn the ignition switch ON.

CHECK:

Measure the voltage between terminal 1 of the air flow meter connector and body ground.

OK:

Voltage: 9 - 14 V

NG

Check for open in harness and connector between EFI main relay (Marking: EFI MAIN) and air flow meter (See page IN-34).

OK

3 Check voltage between terminals VG of engine ECU connector and body ground.

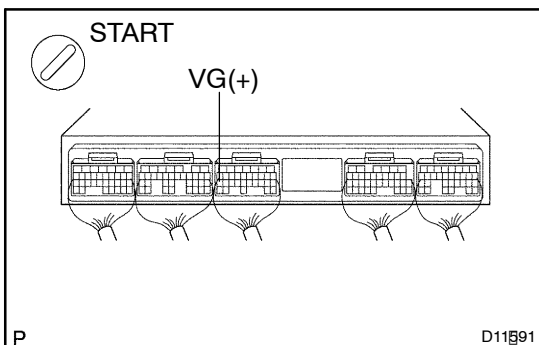

PREPARATION:

- Remove the engine ECU hood and cover.
- Start the engine.

CHECK:

Measure the voltage between terminal VG of the engine ECU connector and body ground while the engine is idling.

OK:

Voltage:

0.2 - 4.9 V (P or N position and A/C switch OFF)

OK

Check and replace engine ECU (See page IN-34).

NG

4 Check for open and short in harness and connector between air flow meter and engine ECU (See page IN-34).

NG

Repair or replace harness or connector.

OK

Replace air flow meter.

5 Check continuity between terminal EVG of engine ECU connector and body ground.

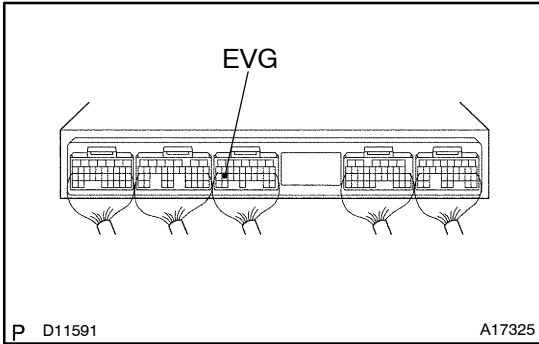

PREPARATION:

Remove the engine ECU hood and cover.

CHECK:

Check the continuity between terminal EVG of the engine ECU connector and body ground.

OK:

Continuity (1 Ω or less)

NG

Check and replace engine ECU
(See page IN-34).

OK

6 Check for open in harness and connector between air flow meter and engine ECU (See page IN-34).

NG

Repair or replace harness or connector.

OK

Replace air flow meter.