

<b>DTC</b>	<b>P0125/91</b>	<b>Insufficient Coolant Temp. for Closed Loop Fuel Control</b>
------------	-----------------	--

**CIRCUIT DESCRIPTION**

To obtain a high purification rate for the CO, HC and NOx components of the exhaust gas, a three-way catalytic converter is used, but for the most efficient use of the three-way catalytic converter, the air-fuel ratio must be precisely controlled so that it is always close to the stoichiometric air-fuel ratio.

The oxygen sensor (bank 1, 2 sensor 1) has the characteristic which its output voltage changes suddenly in the vicinity of the stoichiometric air-fuel ratio. This characteristic is used to detect the oxygen concentration in the exhaust gas and provide the engine ECU with feedback to control of the air-fuel ratio.

When the air-fuel ratio becomes LEAN, the oxygen concentration in the exhaust increases and the oxygen sensor informs the engine ECU of the LEAN condition (small electromotive force: < 0.45 V).

When the air-fuel ratio is RICHER than the stoichiometric air-fuel ratio the oxygen concentration in the exhaust gas is reduced and the oxygen sensor informs the engine ECU of the RICH condition (large electromotive force: > 0.45 V). The engine ECU judges by the electromotive force from the oxygen sensor whether the air-fuel ratio is RICH or LEAN and controls the injection time accordingly. However, if malfunction of the oxygen sensor causes output of abnormal electromotive force, the engine ECU is unable to perform accurate air-fuel ratio control. The oxygen sensors include a heater which heats the zirconia element. The heater is controlled by the engine ECU. When the intake air volume is low (the temperature of the exhaust gas is low) current flows to the heater to heat the sensor for accurate oxygen concentration detection.

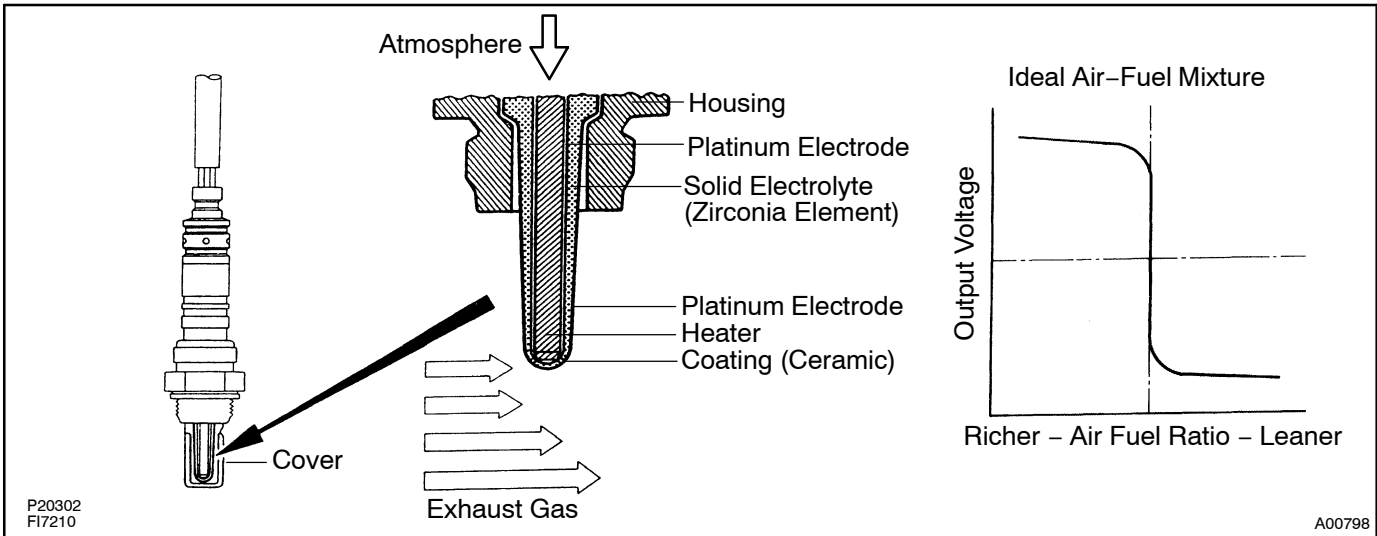

DTC No.	DTC Detecting Condition	Trouble Area
P0125/91	<p>After engine is warmed up, heated oxygen sensors (bank 1, 2 sensor 1) output does not indicate RICH (<math>\geq 0.45</math> V) even once when conditions (a), (b), (c) and (d) continue for at least 90 sec.:</p> <p>(a) Engine speed: 1,400 rpm or more                      (b) Vehicle speed: 40 - 100 km/h (25 - 62 mph)                      (c) Throttle valve does not fully closed                      (d) 180 sec. or more after starting engine</p>	<ul style="list-style-type: none"> <li>• Open or short in oxygen sensor (bank 1, 2 sensor 1) circuit</li> <li>• Oxygen sensor (bank 1, 2 sensor 1)</li> <li>• Air induction system</li> <li>• Fuel pressure</li> <li>• Injector</li> <li>• Gas leakage on exhaust system</li> <li>• Engine ECU</li> </ul>

**HINT:**

After confirming DTC P0125, use the hand-held tester to confirm voltage output of the oxygen sensor (bank 1, 2 sensor 1) from the CURRENT DATA. If voltage output of the oxygen sensor is less than 0.1 V, oxygen sensor circuit may be open or short.

## CONFIRMATION DRIVING PATTERN

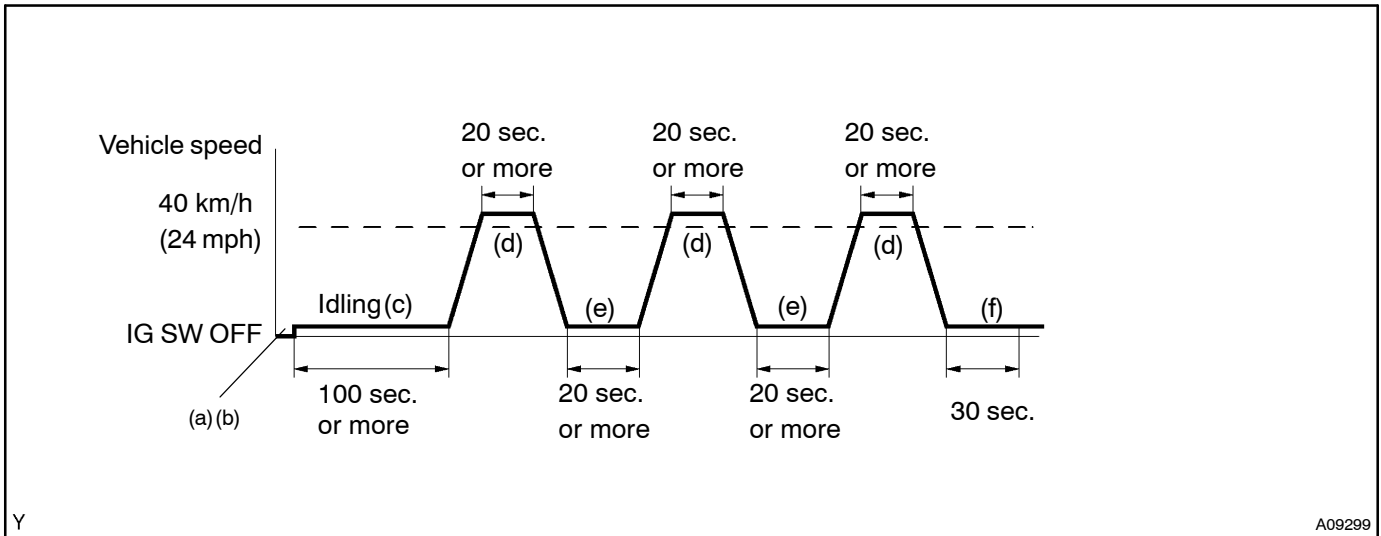

- (a) Connect the hand-held tester to the DLC3.
- (b) Switch the hand-held tester from normal mode to check mode (See page DI-4).
- (c) Start the engine and let the engine idle for 100 seconds or more.
- (d) Drive the vehicle at 40 km/h (24 mph) or more for 20 seconds or more.
- (e) Let the engine idle for 20 seconds or more.
- (f) Let the engine idle for 30 seconds.

### HINT:

If a malfunction exists, the MIL will light up during step (f).

### NOTICE:

**If the conditions in this test are not strictly followed, detection of the malfunction will not be possible. If you do not have a hand-held tester, turn the ignition switch OFF after performing steps (c) to (f), then perform steps (c) to (f) again.**

# WIRING DIAGRAM

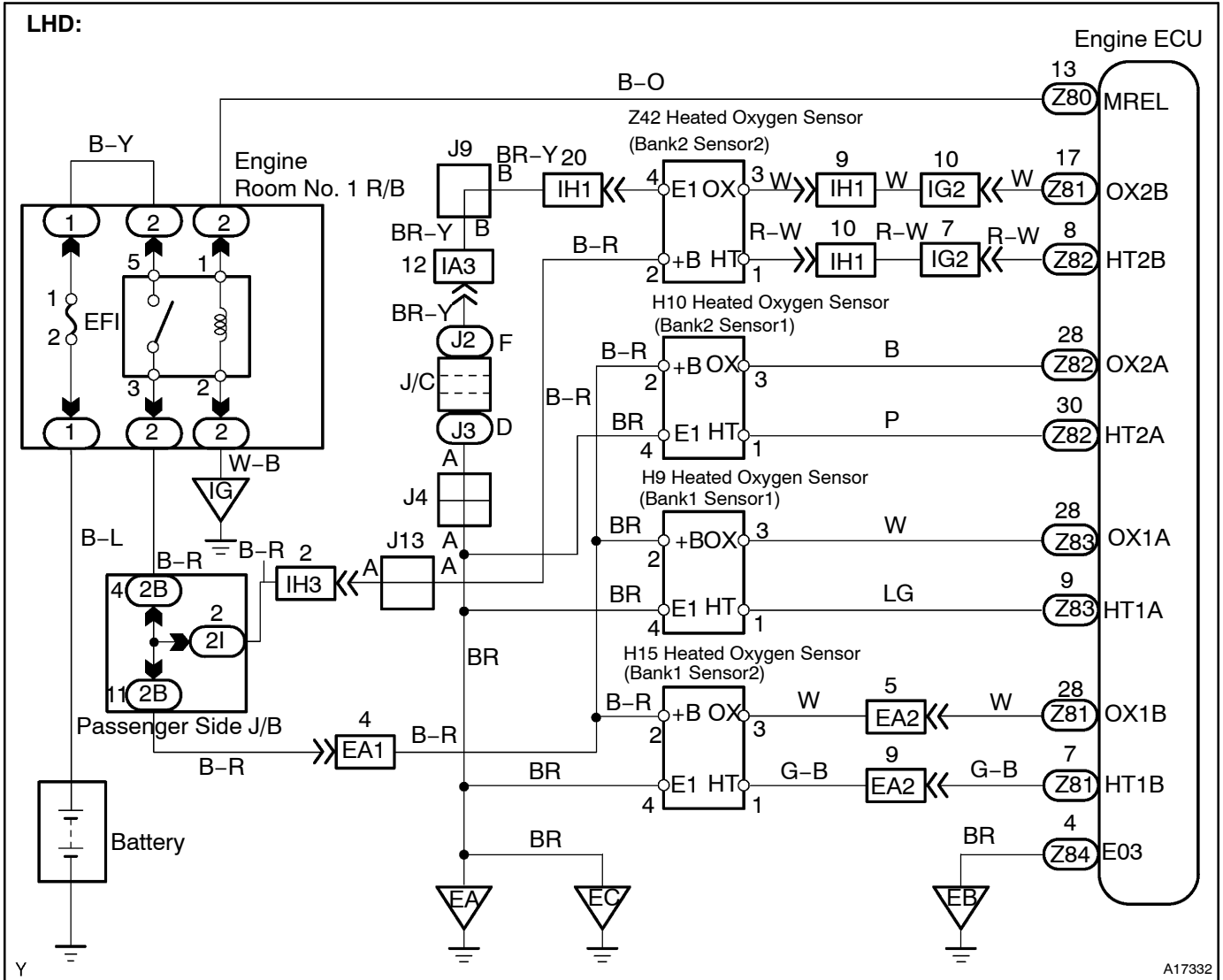

A17332

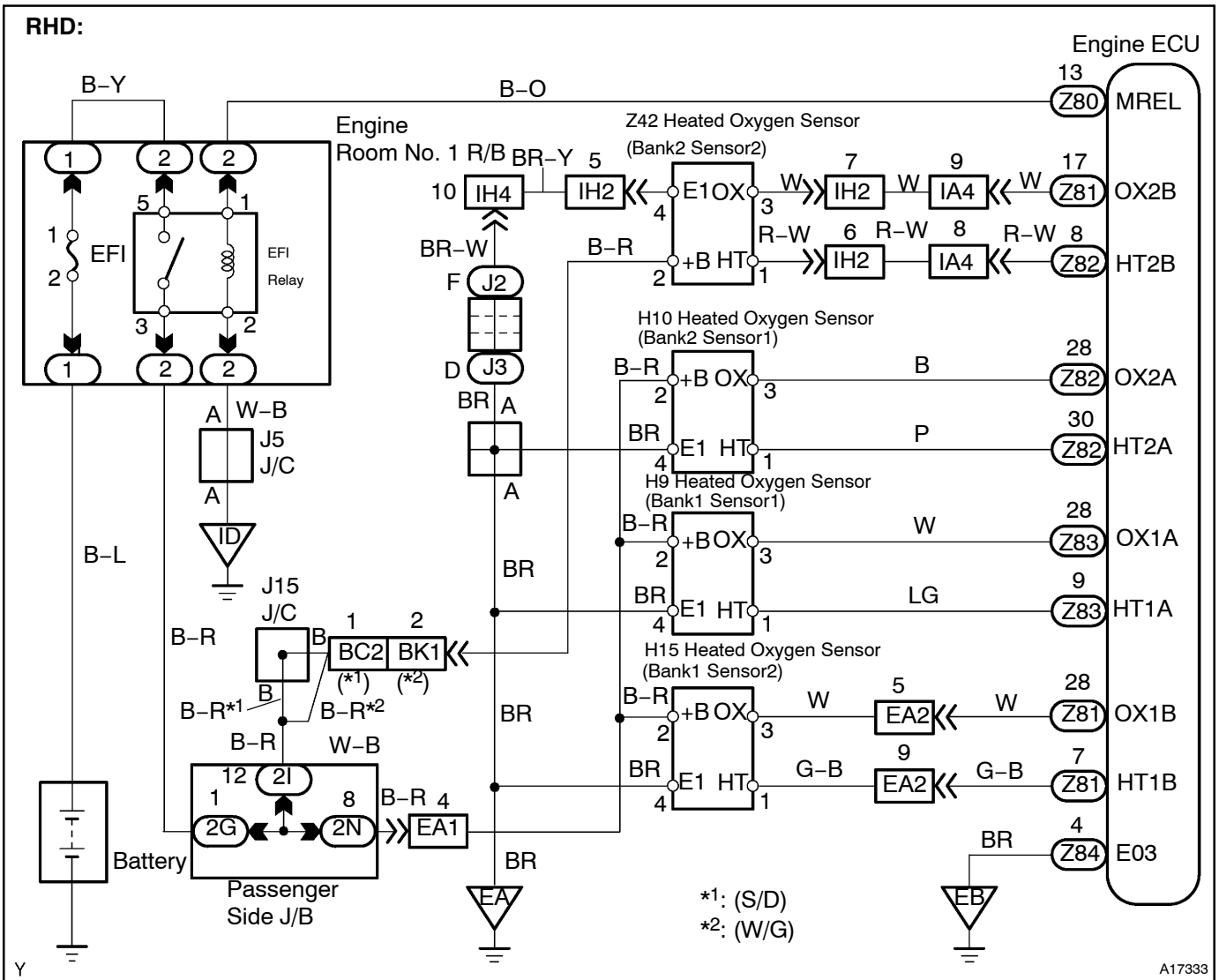

### INSPECTION PROCEDURE

#### When not using hand-held tester:

**HINT:**

- Read freeze frame data using hand-held tester. Because freeze frame records the engine conditions when the malfunction is detected. When troubleshooting it is useful for determining whether the vehicle was running or stopped, the engine was warmed up or hot, the air-fuel ratio was lean or rich, etc. at the time of the malfunction.
- If the vehicle runs out of fuel, the air-fuel ratio is LEAN and DTC P0125 will be recorded. The CHECK ENGINE (MIL) then comes on.

1	<b>Are there any other codes (besides DTC P0125) being output?</b>
---	--

YES	Go to relevant DTC chart (See page DI-17)
-----	---

NO

2	<b>Connect the hand-held tester, and read value for voltage output of oxygen sensors (bank 1, 2 sensor 1).</b>
---	--

**PREPARATION:**

- (a) Connect the hand-held tester to the DLC3.
- (b) Warm up the engine to normal operating temperature (above 75°C (169°F)).

**CHECK:**

Read voltage output of the oxygen sensors when the engine is suddenly raced.

**HINT:**

Perform quick racing to 4,000 rpm 3 times using the accelerator pedal.

**OK:**

**Oxygen sensor output a RICH signal (0.45 V or more) at least once.**

OK	Go to step 9
----	--------------

NG

3 Check for open and short in harness and connector between engine ECU and oxygen sensors (bank 1, 2 sensor 1) (See page IN-34).

NG

Repair or replace harness or connector.

OK

4 Check whether misfire is occurred or not by monitoring DTC and data list.

NG

Perform troubleshooting for misfire (See page DI-76).

OK

5 Check air induction system (See page FI-1).

NG

Repair or replace.

OK

6 Check fuel pressure (See page FI-6).

NG

Check and repair fuel pump, pressure regulator, fuel pipe line and filter (See page FI-1).

OK

7 Check injector injection (See page FI-22).

NG Replace injector.

OK

8 Check gas leakage on exhaust system.

NG Repair or replace.

OK

Replace oxygen sensor (bank 1, 2 sensor 1).

9 Perform confirmation driving pattern.

GO

10 Is there DTC P0125 being output again?

YES Check and replace engine ECU (See page IN-34).

NO

11	Did vehicle runs out of fuel in past?
----	---------------------------------------

NO

Check for intermittent problems  
(See [page DI-4](#))

YES

DTC P0125 is caused by running out of fuel.

**When not using hand-held tester:**

1	Are there any other codes (besides code 91) being output?
---	---

YES

Go to relevant DTC chart ([See page DI-17](#))

NO

Replace oxygen sensor (bank 1, 2 sensor 1).